

ИНСТИТУТ ЗА ФИЗИКУ

ПРИМЉЕНО: 21. 06. 2022			
Рад.јед.	б р о ј	Арх.шифра	Прилог
0901	763/1		

Научном већу Института за физику у Београду

Предмет: Покретање поступка за избор у звање научни сарадник

Молим Научно веће Института за физику у Београду да покрене поступак за мој избор у звање научни сарадник.

У прилогу достављам:

1. Мишљење руководиоца лабораторије са предлогом комисије за избор у звање,
2. Биографске и стручне податке,
3. Преглед научне активности,
4. Елементе за квалитативну оцену научног доприноса,
5. Елементе за квантитативну оцену научног доприноса,
6. Списак објављених радова,
7. Податке о цитираности,
8. Копије објављених радова,
9. Копију докторске дисертације,
10. Уверење о стеченом високом образовању трећег степена докторских студија.

Београд,

____,____,2022.

С поштовањем



Коста Спасић

Научном већу Института за физику у Београду

Предмет: Мишљење руководиоца лабораторије о избору др Косте Спасића у звање научни сарадник

Др Коста Спасић је запослен у Лабораторији за неравнотежне процесе и примену плазми Института за физику у Београду. У свом научном раду се експерименталним приступом бави физиком јонизованих гасова. Поред истраживања која су везана за фундаменталне процесе у овој области, бави се и применама плазми у третманима биолошких и текстилних узорака. С обзиром да испуњава све услове који се предвиђени Правилником о поступку, начину вредновања и квантитативном исказивању научноистраживачких резултата истраживача МПНТР, сагласна сам са покретањем поступка за избор др Косте Спасића у звање научни сарадник.

За састав комисије за избор др Косте Спасића у звање научни сарадник предлажем:

- 1) Др Невена Пуач, научни саветник, Институт за физику у Београду,
- 2) Др Никола Шкоро, виши научни сарадник, Институт за физику у Београду,
- 3) Др Срђан Буквић, редовни професор, Физички факултет, Универзитет у Београду.

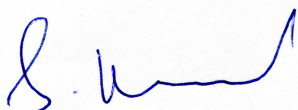

др Гордана Маловић

научни саветник / руководилац Лабораторије за неравнотежне процесе и примену плазми

1. Стручна биографија кандидата

Коста Спасић је рођен 11.08.1984. године у Београду. Основне академске студије, смер Примењена физика и информатика, завршио је 2010. године на Физичком факултету Универзитета у Београду са просечном оценом 8,26. Дипломски рад под називом **„Активација Лангмуирове сонде и мерење концентрације електрона и јона у нискотемпературним плазмама у аргону“** урадио је у лабораторији за Гасну електронику (данас је њено име Лабораторија за неравнотежне процесе и примену плазме) Института за физику у Београду под менторством Др Невене Пуач.

Докторске студије уписао је 2011. године на Физичком факултету Универзитета у Београду, смер – Физика јонизованог гаса и плазме. Положио је све изборне испите са просечном оценом 10.00. Докторску дисертацију под називом **„Дијагностика асиметричног и план паралелног радио-фреквентног система у циљу дефинисања плазма хемијских процеса током третмана узорака органског и неорганског порекла“** урадио је под менторством др Невене Пуач у Лабораторији за неравнотежне процесе и примену плазме у Институту за физику и одбранио је на 3.6.2022. на Физичком факултету Универзитета у Београду.

Коста Спасић је на Институту за физику у Београду запослен од 1.1.2011. године. Радни однос је почео у Лабораторији за гасну електронику која сада носи назив Лабораторија за неравнотежне процесе и примену плазме. До 2019. лабораторијом је руководио др Зоран Љ. Петровића а након тога је под руководством др Гордане Маловић. Звање Истраживач сарадник стекао је на седници Научног већа Института за физику одржаној 29.5.2013. а у исто звање је реизабран на седници одржаној 9.7.2019. године.

Према SCOPUS бази података кандидат је аутор 9 радова који су цитирани 72 пута. Резултате свог рада је представио на већем броју конференција и предавања од чега је у целини штампано 14 а у изводу такође 14.

2. Преглед научне активности кандидата

Истраживања којима се бави кандидат Коста Спасић припадају области физике јонизованих гасова и плазми. Највећи део истраживања урадио је у Лабораторији за неравнотежне процесе и примену плазме (раније Лабораторија за гасну електронику) у Институту за физику у Београду док је један део истраживања реализован је у Лабораторији за технологије површина у Институту Јожеф Штефан у Љубљани. Фокус његових истраживања су нискотемпературске плазме на ниском притиску. Испитивања је до сад радио на два реактора која раде у радиофреквентном домену и на једном реактору који се побуђује микроталасном фреквенцијом. Током рада је применио већи број дијагностичких метода од којих су најважније масена спектрометрија, деривативне сонде и методе оптичке емисионе спектроскопије. Значајни резултати су постигнути и током примена оваквих плазми у третманима биолошких и текстилних узорака.

Асиметрични реактор велике запремине је конструисан у Лабораторији за неравнотежне процесе и примену плазме као прототип уређаја за индустријске третмане текстила. Цилиндричне је геометрије а напајана електрода је направљена од алуминијума и налази се на оси цилиндра. Уземљена електрода је сам зид коморе чиме је постигнута велика асиметрија у односу површина уземљене и напајане електроде. Како би се испитало на који начин промена овог параметра (однос површина уземљене и напајане електроде) може да утиче на особине пражњења, конструисана је и додатна, мања, уземљена електрода. Највећи део истраживања у овом реактору је рађен у смеси гасова коју чини 99% кисеоник (O_2) и 1% аргон (Ar).

Кандидат је за дијагностику плазме користио методу масене спектроскопије. Ова метода је примењена пре свега како би испитао на који начин параметри пражњења утичу на присуство неутралних атома и молекула кисеоника. Ове две врсте су одабране због тога што играју важну улогу током третмана биљака. Током примене ове методе за мерење неутралних врста потребно је одабрати енергију електрона којим се врши јонизација у самом масеном спектрометру. Кандидат је испитивао масене спектре на две енергије: 20 eV и 70 eV. Прва енергија је одабрана да би се избегао процес дисоцијативне јонизације O_2 молекула, пошто је праг за ову реакцију је 23 eV, док је друга изабрана јер је она најчешће коришћена у литератури због тога што је управо на тој енергији највећа вероватноћа јонизације електроном. Пре сваког мерења, на почетку дана, показано је да је систем

потребно оставити два сата у проточном режиму како би се ефекат примеса попут воде и азота који потичу из самог уређаја свео на минимум. Ово је од изузетног значаја код анализе резултата масене спектрометрије. Наиме, резултате је могуће приказати преко укупних одброја за сваку врсту или преко њихових доприноса у укупном масеном спектру, при чему се доприноси изражавају у процентима. У том случају присуство честица које потичу из самог уређаја утиче на укупни масени спектар и тиме на израчунате појединачне доприносе честица, тј. добијене резултате. Мерењима за различите параметре пражњења (притисак и примењена снага) кандидат је показао да доприноси и одброји не зависе на исти начин од притиска и примењене снаге пражњења, јер одброји одређене врсте променом услова пражњења могу да остану константни али њен допринос може да се промени уколико се одброји осталих врста промене.

Допринос атома кисеоника, током мерења са енергијом јонизујућих електрона од 70 eV, је за обе димензије уземљене електроде био практично независтан од примењене снаге али је био нешто већи током мерења без додатне уземљене електроде. Додатно доприноси молекула кисеоника, до одређене снаге, такође нису зависили од примењене снаге након чека је приметан њихов пад. Пад доприноса O₂ молекула је објашњен као последица дисоцијације кисеоника али и примеса које се одређеној увек налазе у реактору. Поред тога, истраживање је показало да услови у којима долази до пада доприноса молекула заправо представљају параметре пражњења на којима се плазма проширила довољно да обухвати отвор за узорковање масеног спектрометра.

Како би измерио присуство побуђених атома и молекула кисеоника, који имају важну улогу током третмана биолошких узорака, кандидат је употребио технику масене спектрометрије прага за јонизацију. Познато је да на различитим површинама може да дође до рекомбинације атома у молекуле али и до деексцитације како молекула тако и атома. Применом ове дијагностичке методе, кандидат је показао да у близини уземљене електроде (зида коморе) побуђених атома практично и нема док је број побуђених молекула значајно мањи у односу на њихов број у централној зони реактора. Овај резултат је веома важан приликом одабира услова пражњења и позиције узорака током третмана плазмом.

Електричне особине плазма система кандидат је дијагностификовао применом деривативних сонди. Показао је да, када додатна електрода није постављена, струјни и напонски сигнали изгледају скоро као правилне синусоиде. Одређено изобличење је

видљиво само на највећим снагама. Након Фуријеове анализе измерених сигнала постало је јасно да до изобличења долази због пораста интензитета, пре свега, другог али и осталих виших хармоника. Када је била постављена додатна уземљена електрода, напонски и донекле струјни сигнали су у временском домену били значајно неправилнији. Показано је да у коришћеном опсегу снага интензитет основног хармоника порасте око 50 % док се интензитет другог хармоника у истом опсегу снага повећа око 5 пута.

Колега се такође бавио и испитивањем струјно-напонских карактеристика оваквог система. Током мерења без додатне уземљене електроде RMS вредности струје константно расту са повећањем примењене снаге док се RMS вредности напона повећавају до одређене снаге након чега престају да се мењају или расту значајно спорије. Оваква промена значи да је импеданса пражњења значајно опала што, поред осталог, одговара преласку плазме из алфа у гама мод. Поређењем струјно напонских особина за две различите димензије уземљене електроде кандидат је показао да плазма ради у сличном режиму само за најмањи притисак и највеће снаге. У тим условима плазма заузима целу запремину реактора. Без додатне електроде, у условима великог притиска и мале снаге, плазма заузима само простор око напајане електроде а улогу уземљене електроде, као код атмосферских пражњења, преузима околни гас. Мерена је и ефикасност оваквог система у предаји снаге плазме и показано је да може да се постигне ефикасност и до 99 %. Струја помераја у овом реактору ни у једном мерном услову није прелазила 50 % укупне струје.

С обзиром на то да је један од циљева истраживања овог кандидата примена плазми у индустрији, било је неопходно да се провери на који начин постављање додатне уземљене електроде може да утиче на проток гасова у оваквом типу реактора. То је урађено дводимензионалном симулацијом коришћењем Flowsquare пакета. Зависно од тога да ли је рачун рађен за случај са или без додатне електроде програму је био потребан различит број корака да се успостави стационарни режим протока. Показано је да када додатне електроде нема, гасови кроз комору теку ламинарно, као флуид кроз било коју цев. Поређењем резултата симулације који су добијени са и без додатне електроде је показано да није било значајне разлике у параметрима попут притиска, брзине и концентрације честица. Тиме је показано да се за обе геометрије реактора у централној зони пражњења налази иста количина гаса.

Поред масене спектрометрије, кандидат је у истраживању применио методе емисионе спектроскопије. Неинвазивна природа ове методе омогућила је бесконтактно испитивање активне зоне пражњења. Такође је примењена и метода оптичке актинометрије са циљем добијања просечне концентрације атома кисеоника дуж просторног угла из којег је прикупљана светлост. За мерење концентрације О атома, спектри су снимани са предње стране коморе у нивоу напајане електроде и у нивоу постоља за узорке, а са бочне стране само у нивоу напајане електроде. Веће концентрације су добијене у нивоу напајане електроде него у нивоу постоља за узорка. Због тога што се са бочне позиције светлост скупља како из светле области око напајане електроде тако и из тамних области око уземљених зидова комора, концентрације које су добијене из спектра снимљених са бочне стране су биле око три пута ниже. Кандидат је показао да је концентрација атома кисеоника у централној области реактора иста за обе димензије уземљене електроде, чиме је поред симулације показао да овај параметар (полупречник уземљене електроде) не утиче на количину активних честица у близини напајане електроде.

Други реактор на којем је кандидат радио је инспирисан дизајном ГЕЦ коморе (*eng Gaseous Electronics Conference*) а такође је конструисан у Лабораторији за неравнотежне процесе и примену плазми. План-паралелне је геометрије а пречник електрода износи 11 cm. Растојање између електрода је могуће подешавати.

За напајање система је коришћен електрични сигнал у радиофреквентном домену, исто као и за асиметрични реактор, а електричне особине реактора план-паралелне геометрије су испитиване током пражњења у два различита гаса, аргону и азоту. Због геометрије овог реактора струја помераја је значајно већа него код асиметричног реактора и чини и преко 50 % укупне струје. Због тога струјни сигнал значајно одступа од синусног облика. У временском домену, он изгледа као суперпозиција два синусна сигнала од којих један има дупло већу фреквенцију. Анализом хармонијског састава је установљено да до тога долази због интензитета другог хармоника струјног сигнала, који је у највећем делу мерних услова имао исти или већи интензитет од основног хармоника. Код напонских сигнала, поред основног, највећи допринос имају други и четврти хармоник. Кандидат је показао да у овом типу реактора на струно-напонске карактеристике промена притиска утиче значајније него промена растојања између уземљене и напајане електроде. Повећање

притиска доводи до повећања RMS вредности струје али и до пада напона који је потребан за одржавање пражњења.

Кандидат је методе оптичке емисионе спектроскопије применио и за дијагностику план паралелног реактора. Као радни гас је одабран азот јер је овај реактор коришћен током третмана памучних узорака у азотној плазми. Циљ примене ове методе је био да се види да ли је могуће уочити неки феномен који би био мера интеракција плазме са површином а на основу ког би могло да се закључи када је време да се третман прекине. Због тога је урађена оптичка емисиона спектроскопија пражњења са ICCD камером као детектором на спектрометру при чему је коришћен режим кинетичке серије чиме је омогућено да се прати временска еволуција емисионих линија од интереса. Поређена је еволуција две различите линије са чела Друге позитивне траке молекула азота. С обзиром да је утврђено да обе линије еволуирају у времену на исти начин, за анализу је коришћена само линија на 337,1 nm. Затим је поређена емисија током третмана памучног узорка и током пражњења без узорка у комори. Примећено је да је интензитет емисије јачи током третмана али да током третмана опада и то је пад израженији уколико је номинална снага већа. Пад интензитета линије на највећим примењеним снагама временом успорава и затим престаје да се мења. Поређењем емисије из три различите врсте узорака је установљено да је интензитет емисије већи уколико је хидрофилност третираног материјала већа. Анализом резултата и користећи претпоставке о доминантним хемијским реакцијама између честица из плазме и површине узорка установљено је да разлог појачане емисије азотове линије лежи у сударним процесима азота са водом и ОН радикалима. Показано је додатно да азот у сударним процесима може да се побуди и ОН радикалима чије порекло није вода која у комору улази са узорком већ који у плазму улазе након избијања из структуре третираног материјала.

Резултате и дискусију до сада описаних истраживања кандидат је представио у својој докторској дисертацији:

- **К. Спасић**, „Дијагностика асиметричног и план паралелног радио-фреквентног система у циљу дефинисања плазма хемијских процеса током третмана узорака органског и неорганског порекла“, Физички факултет, Универзитет у Београду, 2022.

У план-паралелном реактору реактору је кандидат је Лангмуировом сондом испитивао просторну расподелу параметара попут плазменог потенцијала, температуре и концентрације електрона. Показао је да су плазмени потенцијал и концентрација електрона највећи у централном делу реактора и да опадају са повећањем растојања од централне осе реактора. Међутим, показано је и да температура електрона не зависи од овог растојања већ искључиво од примењене снаге. Ови резултати су приказани у монографској студији у тематском зборнику међународног значаја (M14):

- Miglena Dimitrova, Tsv. Popov, Nevena Puač, Nikola Škoro, **Kosta Spasić**, Gordana Malović, Francisco M. Dias and Zoran Lj. Petrović, Radial profile of the electron energy distribution function in RF capacitive gas-discharge plasma, Journal of Physics: Conference Series 700 (2016) 012007
DOI:10.1088/1742-6596/700/1/012007
(M14)

Осим радио фреквентних плазми, кандидат је радио и на дијагностици извора који је побуђен микроталасним сурфатроном. Тај реактор је конструисан у Институту Јожеф Штефан у Љубљани где су и урађена мерења. Ова мерења су рађена у области која је далеко од извора пражњења али у којој има много побуђених честица, тзв. област пост-пражњења (*eng afterglow*). Мерена је концентрација атома кисеоника уз помоћ каталитичке сонде. Циљ ових истраживања је био да се види на који начин ће промена димензија конуса на крају цеви за увод гасова да утиче на концентрацију атома кисеоника у оваквом типу реактора. У истраживању је показано да шири конус подстиче дифузију гаса и да ће коришћењем широких конуса бити постигнута већа концентрација атома кисеоника и у оним областима реактора који су далеко од централног протока гасова. Поред тога, примећено је да, осим у најудаљенијим деловима реактора, концентрација О атома ипак зависи пре свега од протока гасова. Резултати ових истраживања су презентовани у већ поменутој дисертацији кандидата.

Поред дијагностике пражњења, кандидат се бавио и применама плазми у третманима биолошких и текстилних узорака.

Биолошке узорке кандидат је третирао у асиметричном реактору велике запремине. Третирано је семе моделне биљке Царичиног дрвета (*paulownia tomentosa*). Циљ је био да се види на који начин третман семена плазмом утиче на активност ензима у младицама током периода клијања. Показано је да последњег дана у првој фази клијања активност била

већа у оним младицама које су биле третиране на већем притиску и уколико је третман дуже трајао. Третирано је и семе комерцијалних биљака пшенице и кукуруза са циљем испитивања утицаја на клијавост и на степен инфекције семена. Кандидат је демонстрирао могућност да се оваквим плазмама повећа клијавост биљака и да се смањи степен инфекције. Указао је и на то да је услове третмана потребно пажљиво одабрати јер уколико је примењена превелика снага или су третмани превише дугачки, резултати третмана постају веома негативни. Ови резултати су представљени у дисертацији кандидата и једном врхунском међународном часопису (M21):

- Nevena Puač, Nikola Škoro, **Kosta Spasić**, Suzana Živković, Milica Milutinović, Gordana Malović and Zoran Lj. Petrović, „Activity of catalase enzyme in Paulownia tomentosa seeds during the process of germination after treatments with low pressure plasma and plasma activated water“, Plasma Processes and Polymers ,2017,1700082; DOI: 10.1002/ppap.201700082 (M21, ИФ=2.846)

Кандидат се бавио и третманом текстилних узорака са циљем побољшања адхезије након наношења микрокапсула. У асиметричном реактору тканине памука су третиране са циљем наношења мирисних микрокапсула а третмани су рађени у кисеонику и азоту као радним гасовима. Показано је да се третманима и у једном и другом гасу може утицати на физичка својства узорака. Након кисеоничних третмана на узорцима су биле видљивије морфолошке промене, док су мирисне микрокапсуле биле отпорније на прање тј. имале су бољу адхезивност уколико је узорак третиран у азоту. Ови резултати су представљени у оквиру чланка у истакнутом међународном часопису (M22):

- Mateja Kert, Petra Forte Tavčer, Aleš Hladnik, **Kosta Spasić**, Nevena Puač, Zoran Lj. Petrović and Marija Gorjanc, „Application of Fragrance Microcapsules onto Cotton Fabric after Treatment with Oxygen and Nitrogen Plasma“, Coatings, 2021, 11, 1181 DOI: 10.3390/coatings11101181 (M22, ИФ=2.881)

У реактору план паралелне геометрије рађен је третман текстила у азоту са циљем наношења UV-респонсивних микрокапсула. Кандидат је показао да је за фиксирану улазну снагу третман утолико успешнији уколико је растојање између уземљене и напајане електроде веће. Такође је показао да, као и код биолошких узорака, треба водити рачуна при одабиру услова третмана. Уколико су услови такви да је плазма сувише интензивна, површина узорка може да се оштети у третману. Након излагања плазми, на површини

узорака је до пораста количине карбоксилних и N-H група. Примећено је да до повећања количине N-H група на површини долази и у узорцима који су били на ниском притиску у азоту без укључивања плазме. Резултате овог истраживања, кандидат је представио у оквиру своје дисертације.

У реактору микроталасне побуде кандидат је третирао узорке текстила памука у амонијаку и кисеонику. Третмани су рађени или само у једном од гасова или прво у кисеонику а након тога у амонијаку. Показано је да се оваквим третманима може утицати на особине узорка као што су хидрофилност, боја или ваздушна пермеабилност. Најважнији закључак је да се најбољи резултати постижу уколико се узорак третира прво у кисеонику па затим и азоту. Резултати овог истраживања приказани су у раду у истакнутом међународном часопису (M21):

- Marija Gorjanc, Miran Mozetič, Gregor Primc, Alenka Vesel, **Kosta Spasić**, Nevena Puač, Zoran Lj. Petrović and Mateja Kerta, „Plasma treated polyethylene terephthalate for increased embedment of UV-responsive microcapsules“, Applied Surface Science 419 (2017) 224–234;
DOI: 10.1016/j.apsusc.2017.04.177
(M21 ИФ=4.439)

3. Елементи за квалитативну оцену научног доприноса кандидата

3.1. Квалитет научних резултата

3.1.1. Научни ниво и значај резултата, утицај научних радова

Током свог досадашњег рада кандидат се бавио електричном карактеризацијом два различита плазма реактора на ниском притиску, оптичком и масеном спектроскопијом као и применом Лангмуирове и каталитичке сонде. Најзначајније резултате постигао је електричном карактеризацијом асиметричног и план паралелног система, пре свега током испитивања хармонијског састава струје и напона. Оваквим испитивањима се до сада бавио мали број истраживача и то скоро искључиво у план паралелним системима. Кандидат је показао, између осталог, да повећањем односа површина уземљене и напајане електроде долази до изобличења сигнала у временском домену због пораста доприноса, пре свега, другог али и осталих виших хармоника. Показао је и да, код асиметричног реактора, промена димензије уземљене електроде не утиче на концентрацију честица у активној зони пражњења. Додатно је демонстрирао да, у две различите врсте реактора, у близини уземљеног зида коморе долази до значајног пада концентрације активних честица. Истакао је и важност плазма хемије, пре свега присуство воде и ОН радикала, током третмана текстилних узорака.

У области примене нискотемпературских плазми на ниском притиску, кандидат је доказао да се третманима семена у оваквим плазмама може утицати на метаболизам и клијавост семена биљака али и на смањење степена инфекције семена. Третманом семена моделне биљке Царичиног дрвета расте активност ензима у младицама током процеса клијања а овом процесу погодује дужи третман и виши притисак. Такође, може да се повећа већ висока клијавост комерцијалног семена и да се значајно смањи степен инфекције али треба водити рачуна о томе да не дође до оштећена третираних семена услед превише интензивне плазме.

Током третмана текстилних узорака памука, кандидат је показао да кисеоничне плазме изазивају појаву микро-бразди на површини узорака док азотне плазме подстичу формирање функционалних група на површини памука. Уколико је циљ да се на узорке нанесу микрокапсуле, најбољи резултати се постижу ако се узорак прво изложи кисеоничној а након тога и плазми која садржи азот.

Комисија као најзначајније истиче 2 следећа рада

- Nevena Puač, Nikola Škoro, **Kosta Spasić**, Suzana Živković, Milica Milutinović, Gordana Malović and Zoran Lj. Petrović, „Activity of catalase enzyme in Paulownia tomentosa seeds during the process of germination after treatments with low pressure plasma and plasma activated water“, Plasma Processes and Polymers ,2017,1700082;
DOI: 10.1002/ppap.201700082
(M21, ИФ=2.846)
- Marija Gorjanc, Miran Mozetič, Gregor Primc, Alenka Vesel, **Kosta Spasić**, Nevena Puač, Zoran Lj. Petrović and Mateja Kerta, „Plasma treated polyethylene terephthalate for increased embedment of UV-responsive microcapsules“, Applied Surface Science 419 (2017) 224–234;
DOI: 10.1016/j.apsusc.2017.04.177
(M21 ИФ=4.439)

У оквиру првог рада мерена је активност и количина ензима каталазе у младицама Царичиног дрвета током прве фазе клијања. Поређене су биљке чије је семе било изложено деловању плазмом активирание воде са биљкама чије је семе третирано плазмом на ниском притиску. Током припреме овог рада кандидат је био најактивнији у оквиру експерименталног дела везаног за третмане семена на ниском притиску, укључујући одабир услова третмана и извођење самих експеримената. Третман семена је рађен на притисцима од 200 mTorr и 600 mTorr у кисеонику. Примењена снага је била 100 W, док су времена третмана била 1 min, 5 min, 10 min и 20 min. Показано је да су последњег дана прве фазе клијања и активност и садржај каталазе били већи у оним младицама чије је семе било третирано на већем притиску и уколико је третман дуже трајао.

У другом раду је рађен третмана текстила са циљем појачане апсорпције и адхезије микрокапула. Третман је рађен у микроталасном реактору области пост-пражњења (*eng afterglow*) у кисеонику и амонијаку. Поређена је промена физичких особина узорака попут боје, дубине и јачине боје, хидрофилности, ваздушне пермеабилности и масе а електронским микроскопом је анализирана и површина тканине. ПЕТ тканина је излагана или кисеонику или амонијаку или прво кисеонику па затим исти узорак амонијаку. Показано је да се значајно бољи резултати постижу ако се узорци третирају у оба гаса. На пример, XPS анализом површине узорка је показано да се након 100 секунди третмана у амонијаку на његовој површини налази 0,8 % азота. Међутим, уколико се узорак третира прво 100 секунди у кисеонику па затим још 3 секунде у амонијаку, на његовој површини ће се налазити 2,5 % азота. С обзиром да је у питању блага плазма, до оштећења узорка не може да дође а третман ће бити утолико успешнији уколико је дуже трајао. Ипак, показано

је да се највеће промене догађају у првим минутима третмана а да важнију улогу, за апсорпцију микрокапула, игра време излагања амонијаку а не кисеонику.

3.1.2. Позитивна цитираност научних радова кандидата

Према бази Google Scholar бази података радови др Косте Спасића су цитирани 146 пута (без аутоцитата 140), а Хиршов индекс је 5 док је према SCOPUS бази података цитиран 72 пута а Хиршов индекс је 4.

3.1.3. Параметри квалитета радова и часописа

Кандидат др Коста Спасић је објавио укупно 5 радова у међународним часописима и то:

- 1 рад у врхунском међународном часопису (M21) Journal of Physics D: Applied Physics (IF=2.521 SNIP=1.458 (вредности за 2013. годину))
- 1 рад у врхунском међународном часопису (M21) Plasma Processes and Polymers (IF=2.7 SNIP=1.02 (вредности за 2017. годину))
- 1 рад у врхунском међународном часопису (M21) Applied Surface Science (IF=4.439 SNIP=1.33 (вредности за 2017. годину))
- 1 рад у истакнутом међународном часопису (M22) Coatings (IF= 2.881 SNIP=0.98 (вредности за 2020. годину))
- 1 рад у међународном часопису (M23) The European Physical Journal D (IF=1.425 SNIP=0.64 (вредности за 2020. годину))

Укупан импакт фактор објављених радова др Косте Спасића износи 13.996. Додатни библиометријски показатељи према упутству о начину писања извештаја о изборима у звања које је усвојио Матични научни одбор за физику су:

	ИФ	М	СНИП
Укупно	13.996	32	5.428
Усредњено по чланку	2.799	6.4	1.086
Усредњено по аутору	1.826	4.19	0.761

3.1.4. Степен самосталности и степен учешћа у реализацији радова у научним центрима у земљи и иностранству

Исказано у оквиру тачке 3.1.1. Такође, колега Спасић је учествовао:

- 2014. у оквиру COST акције TD1208 је учествовао у тренинг школи под називом „Chemistry initiated by electrical discharges with liquids“ која је одржана од 3. до 6. фебруара у Јожеф Штефан институту у Љубљани, Словенија

- 2013. у оквиру COST акције MP1101 присуствовао је тренинг школи под називом „Bad Honnef Summer School and Master Class“ која је одржана од 6. до 12. октобра у Бад Хонефу, Немачка.

3.1.6. Елементи применљивости научних резултата

Докторска дисертација Косте Спасића је усмерена у целости на примењивост неравнотежних плазми у текстилној индустрији и пољопривреди што може детаљније да се види из тачке 2 и тачке 3.1.1.

3.3. Нормирање броја коауторских радова, патената и техничких решења

Сви публиковани радови др Косте Спасића спадају у радове експерименталне природе. Према Правилнику о поступку и начину вредновања и квантитативном исказивању научноистраживачких резултата истраживача у случају експерименталних радова предвиђено је до 7 коаутора. Укупан ненормиран број бодова је 58 док је нормиран број М бодова 53,07 што је знатно више у односу на захтеваних 16 бодова за избор у научног сарадника.

3.4. Учешће на пројектима МПНТР Републике Србије

Др Коста Спасић је учествовао на пројектима Министарства просвете, науке и технолошког развоја:

2012.–2019. „Примене нискотемпературних плазми у биомедицини, заштити човекове околине и нанотехнологијама“ (ИИИ41011).

2012.–2019. Фундаментални процеси и примене транспорта честица у неравнотежним плазмама, траповима и наноструктурама (ОН171037)

Учесник је Центра изврности - Центра за неравнотежне процесе под руководством академика Зорана Петровића.

3.5. Активности у научним и научно-стручним друштвима

3.5.1. Организација научних скупова

Др Коста Спасић је био у локалном организационом комитету следећих међународних конференција:

27th Summer School an International Symposium on the Physics of Ionized Gases, од 26. до 29. августа 2014. године у Београду, Република Србија

22nd International Conference on Gas Discharges and Their Applications, од 2. до 7. септембра 2018. године у Новом Саду, Република Србија.

XX International Workshop on Low-Energy Positron and Positronium Physics, XXI International Symposium on Electron-Molecule Collisions and Swarms, V Workshop on Non-Equilibrium Processes POSMOL 2019, од 18 до 21 јула 2019. године у Београду, Република Србија.

3.6. Утицај научних резултата

Утицај научних резултата се огледа у броју цитата који су наведени у тачки 3.1.2. овог одељка, а значај резултата је описан у оквиру одељка 3.1.1. Пун списак радова и подаци о цитираности из Scopus базе су дати у прилогу.

3.7. Конкретан допринос кандидата у реализацији радова у научним центрима у земљи и иностранству

Кандидат своју истраживачку и научну активност реализовао у Институту за физику у Лабораторији за гасну електронику под руководством академика Зорана Љ. Петровића која данас носи назив Лабораторија за неравнотежне процесе и примену плазме а којом руководи др Гордана Маловић. Његов научни допринос је важан у оквиру експеримената везаних за хармонијски састав електричних сигнала, масени састав и присуство побуђених честица и апсолутну концентрацију атома кисеоника у асиметричном реактору. Значајно је допринео и експериментима у план паралелном реактору током дефинисања плазма-хемијских процеса приликом третмана текстилних узорака, као и третману семена. Објављеним радовима, на које је потписан као коаутор, је дао допринос кроз експериментални рад, обраду и анализу резултата.

4. Елементи за квантитативну оцену научног доприноса кандидата

Остварени М-бодови по категоријама публикација

Категорија	М-бодови по публикацији	Број публикација	Укупно М-бодова	Нормирани број М-бодова
M14	4	2	8	7.33
M21	8	3	24	21.34
M22	5	1	5	5
M23	3	1	3	2.14
M31	1	12	12	11.34
M34	0,5	12	6	5.917

*Нормирање је урађено у складу са Прилогом 1 Правилника.

	Потребно	Остварено	Остварено (нормирано*)
Укупно	16	58	53.07
M10+M20+M31+M32+M33+M34+M41+M42	10	18	17.26
M11+M12+M21+M22+M23	6	40	35.81

*Нормирање је урађено у складу са Прилогом 1 Правилника.

5. СПИСАК ОБЈАВЉЕНИХ РАДОВА:

5.1 Монографске студије у тематским зборницима међународног значаја M14

- 1) “Biomedical applications and diagnostics of atmospheric pressure plasma“, Zoran Lj. Petrović, Nevena Puač, Saša Lazović, Dejan Maletić, **Kosta Spasić** and Gordana Malović, Journal of Physics: Conference Series 356 (2012) 012001
DOI: 10.1088/1742-6596/356/1/012001
- 2) „Radial profile of the electron energy distribution function in RF capacitive gas-discharge plasma“, Miglena Dimitrova, Tsv. Popov, Nevena Puač, Nikola Škoro, **Kosta Spasić**, Gordana Malović, Francisco M. Dias and Zoran Lj. Petrović, Journal of Physics: Conference Series 700 (2016) 012007
DOI:10.1088/1742-6596/700/1/012007

5.2 Радови у врхунским међународним часописима M21

- 1) „Plasma properties in a large-volume, cylindrical and asymmetric radio-frequency capacitively coupled industrial-prototype reactor“, Saša Lazović, Nevena Puač, **Kosta Spasić**, Gordana Malović, Uroš Cvelbar, Miran Mozetič, Maja Radetić and Zoran Lj Petrović, Journal of Physics D: Applied Physics. 46 (2013) 075201 (8pp),
DOI: 10.1088/0022-3727/46/7/075201
(IF= 2.521, SNIP=1.458)
- 2) „Activity of catalase enzyme in Paulownia tomentosa seeds during the process of germination after treatments with low pressure plasma and plasma activated water“, Nevena Puač, Nikola Škoro, **Kosta Spasić**, Suzana Živković, Milica Milutinović, Gordana Malović and Zoran Lj. Petrović, Plasma Processes and Polymers 2017,1700082;
DOI: 10.1002/ppap.201700082
(IF=2.7 SNIP=1.02)
- 3) „Plasma treated polyethylene terephthalate for increased embedment of UV-responsive microcapsules“, Marija Gorjanc, Miran Mozetič, Gregor Primc, Alenka Vesel, **Kosta Spasić**, Nevena Puač, Zoran Lj. Petrović and Mateja Kerta, Applied Surface Science 419 (2017) 224–234;
DOI: 10.1016/j.apsusc.2017.04.177
(IF=4.439 SNIP=1.33)

5.3 Радови у истакнутим међународним часописима M22

- 1) „Application of Fragrance Microcapsules onto Cotton Fabric after Treatment with Oxygen and Nitrogen Plasma“, Mateja Kert, Petra Forte Tavčer, Aleš Hladnik, **Kosta Spasić**, Nevena Puač, Zoran Lj. Petrović and Marija Gorjanc, Coatings, 2021, 11, 1181
DOI: 10.3390/coatings11101181
(IF= 2.881 SNIP=0.98)

5.4 Радови у међународним часописима M23

- 1) „Helium atmospheric pressure plasma jet parameters and their influence on bacteria deactivation in a medium“, Andrea Jurov, Nikola Škoro, **Kosta Spasić**, Martina Modic, Nataša Hojnik, Danijela Vujošević, Milena Đurović. Zoran Lj. Petrović, Uroš Cvelbar, The European Physical Journal D, 76(2), pp.1-11
DOI: 10.1140/epjd/s10053-022-00357-y
(IF=1.425 SNIP=0.64)

5.5 Саопштења са међународних конференција штампана у целини M31

- 1) Z.Lj. Petrović, N. Puač, D. Marić, D. Maletić, **K. Spasić**, N. Škoro, J. Sivoš, S. Lazović, G. Malović, “ Development of Biomedical Applications of Nonequilibrium Plasmas and Possibilities for Atmospheric Pressure Nanotechnology Applications“, PROC. 28th International Conference On Microelectronics (MIEL 2012), Niš, Serbia, 13-16 May, 2012
- 2) S. Lazović, **K. Spasić**, N. Puač, G. Malović, U. Cvelbar, M. Mozetič, Z. Lj. Petrović, „Spatial profiles of atomic oxygen concentrations in a large scale CCP reactor“, ESCAMPIG XXI, Viana do Castelo, Portugal, July 10-14 2012
- 3) **Kosta Spasić**, Saša Lazović, Nevena Puač, Zoran Lj Petrović, Gordana Malović, Miran Mozetič and Uroš Cvelbar, „Catalytic probe measurements of atomic oxygen concentration in large volume oxygen CCP“ 26th SPIG, Zrenjanin, Serbia, August 27-31 2012
- 4) Saša Lazović, Nevena Puač, **Kosta Spasić**, Gordana Malović, Uroš Cvelbar, Miran Mozetič and Zoran Lj. Petrović, “Diagnostics of a large scale CCP reactor suitable for textile treatments”, 4th ICAPT, Strunjan, Slovenia, EU, September 9-13 2011
- 5) S. Lazović, N. Puač, **K. Spasić**, G. Malović, U. Cvelbar, M. Mozetič, Z. Lj. Petrović, „Measurements of atomic oxygen concentrations in a large scale asymmetric capacitively coupled plasma reactor by using catalytic probes“, 30th ICPIG, August 28th – September 2nd 2011, Belfast, Northern Ireland, UK
- 6) **K. Spasić**, N. Škoro, N. Puač, G. Malović and Z. Lj. Petrović, „Reactive species production in oxygen low-pressure RF plasma suitable for treatment of sensitive surfaces“, 3rd CEAMPP, August 25th 2013, Belgrade, Serbia
- 7) I. Filatova, V. Azharonok, V. Lushkevich, A. Zhukovsky, **K. Spasić**, S. Živković, N. Puač, S. Lazović, G. Malović and Z.Lj.Petrović, „Plasma seeds treatment as a promising technique for seed germination improvement“, 31st ICPIG, 14-19 July 2013, Granada, Spain
- 8) N. Škoro, **K. Spasić**, N. Puač, G. Malović AND Z. Lj. Petrović, „Diagnostics of low-pressure rf oxygen plasma suitable for treatment of sensitive surfaces“, 20th International Conference on Gas Discharges and their Applications, 6th - 11th July 2014, Orleans, France
- 9) **K. Spasić**, N. Škoro, N. Puač, G. Malović, Z. Lj. Petrović, „Ion energy distribution and line intensities in asymmetrical oxygen rf discharge“, August 26th – 29th 2014, Belgrade, Serbia
- 10) **K. Spasić**, N. Puač, N Škoro, G. Malović and Z.Lj. Petrović, „Characterization of a large volume oxygen RF discharge suitable for low-pressure treatment of sensitive samples“, 32nd ICPIG, July 26th-31st, 2015, Iași, Romania
- 11) **Spasić Kosta**, Škoro Nikola, Puač Nevena, Malović Gordana, and Petrović Lj Zoran, "Production of active oxygen species in low pressure CCP used for sterilization of commercial

seeds." 2015 IEEE International Conference on Plasma Sciences (ICOPS). IEEE, 2015, may 24-28, Belek, Antalya, Turkey

- 12) **Kosta Spasić**, Nevena Puač, Gordana Malović and Zoran Lj Petrović, „Effects of power transfer efficiency and grounded electrode surface on creation of O and O₂ excited species in low pressure plasmas“, 24th International Symposium on Plasma Chemistry (ISPC), Naples, Italy, June 9-14 2019

5.6 Саопштења са међународних конференција штампана у изводу М34

- 1) Sasa Lazovic, **Kosta Spasic** Nevena Puac and Gordana Malovic, „Catalytic probe measurements in a large scale CCP reactor“, 64th GEC, Salt Lake City, Utah, USA, November 2011
- 2) Saša Lazović, Nevena Puač, **Kosta Spasić**, Gordana Malović and Zoran Lj. Petrović, „Characterization of a large scale RF CCP reactor using Langmuir and derivative probes“, 20th ISPC, Philadelphia, USA, July 24-29, 2011
- 3) Saša Lazović, Nevena Puač, **Kosta Spasić**, Gordana Malović, Zoran Lj. Petrović, Uroš Cvelbar, Miran Mozetič, „Probe diagnostics of a large scale asymmetric capacitively coupled plasma reactor“, 18th International scientific meeting on vacuum science and techniques, Bohinjko Jezero, Slovenia, EU, June 2-3 2011
- 4) S. Lazović, N. Puač, **K. Spasić**, G. Malović, Z. L. Petrović, „Langmuir probe measurements of a large scale RF CCP reactor“, 2nd International workshop on plasma nano-interfaces and plasma characterization, Cerklje, Slovenia, EU, March 1-4, 2011
- 5) **K. Spasić**, N. Škoro, N. Puač, G. Malović and Z. Lj. Petrović, „Atomic species produced in large scale oxygen plasma used for treatments of sensitive materials“, 66th Annual Gaseous Electronics Conference, Princeton, New Jersey, USA September 30 - October 4, 2013.
- 6) N. Puač, **K. Spasić**, N. Škoro, M. Gorjanc, G. Malović and Z Lj Petrović, “Optical Emission Diagnostics of N₂ plasma used for textile pretreatment”, ESCAMPIG XXIII, Bratislava, Slovakia, July 12-16, 2016
- 7) N Skoro, N Puac, **K Spasic**, G Malovic, M Gorjanc, Z Lj Petrovic, „Optical emission spectroscopy of OH lines in N₂ and Ar plasmaduring the treatments of cotton fabric“, 69th GEC, October 10-14, 2016, Bochum, Germany
- 8) Z.Lj. Petrović, N. Puač, G. Malović, N. Selaković, **K. Spasić**, D. Maletić, S. Živković, „Diagnostics of atmospheric pressure plasma jets and plasma needle and their application in biology and medicine“, GEM 2016, Geelong, Australia, February 14-17, 2016.
- 9) N. Puač, N. Škoro, **K. Spasić**, S. Živković P, M. Milutinović, V. Šašić G. Malović and Z.Lj. Petrović, “Activity of catalase enzyme in *P. tomentosa* seeds after direct plasma treatments and treatments with plasma activated water”, XXXIII ICPIG, July 9-14, 2017, Estoril/Lisbon, Portugal
- 10) Nevena Puač, Nikola Škoro, **Kosta Spasić**, Suzana Živković, Milica Milutinović, Gordana Malović and Zoran Lj. Petrović, “Activity of Catalase Enzyme in Paulownia Tomentosa Seeds as a Result of a Direct and Indirect Treatment by the Non-Equilibrium Plasma”, JSPP2017, 4-7 december 2017, Osaka, Japan.
- 11) N. Škoro, N. Puač, **K. Spasić**, M. Gorjanc, G. Malović and Z. Lj. Petrović, “Monitoring of the cotton fabric plasma treatments by using optical emission spectroscopy”, XII FLTPD, April 23th—27th 2017, Zlatibor, Serbia

K Spasić, N Škoro, N Puač, G Malović, Z Lj. Petrović, “Volume Scaling in Production of Active Oxygen Species in an Asymmetrical Plasma Reactor”, GD2018, september 2-7, 2018, Novi Sad, Serbia

Spasić, Kosta

[University of Belgrade, Belgrade, Serbia](#)

<https://orcid.org/0000-0001-6934-4213>

[Edit profile](#)

[Set alert](#)

[Save to list](#)

[Potential author matches](#)

[Export to SciVal](#)

Metrics overview

9

Documents by author

73

Citations by 73 documents

4

h-index: [View *h*-graph](#)

Document & citation trends

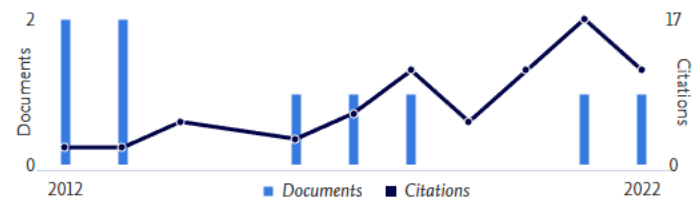

Most contributed Topics 2016–2020

[Plasma Jets; Atmospheric Pressure; Reactive Nitrogen Species](#)

[1 document](#)

[Wool Fibers; Plasma Treatment; Atmospheric Pressure](#)

[1 document](#)

[Electrostatic Probes; Energy Function; Distribution Function](#)

[1 document](#)

[View all Topics](#)

[9 Documents](#)

[Cited by 73 Documents](#)

[0 Preprints](#)

[33 Co-Authors](#)

[3 Topics](#)

[0 Awarded Grants](#)

Beta



Kosta Spasic

[institute of physics, Belgrade](#)

Verified email at ipb.ac.rs

[plasma physics](#)

FOLLOW

<input type="checkbox"/>	TITLE			CITED BY	YEAR
<input type="checkbox"/>	Plasma seeds treatment as a promising technique for seed germination improvement I Filatova, V Azharonok, V Lushkevich, A Zhukovsky, G Gadzhieva, ... Proceeding of the 31st International Conference on Phenomena in Ionized ...			57	2013
<input type="checkbox"/>	Activity of catalase enzyme in <i>Paulownia tomentosa</i> seeds during the process of germination after treatments with low pressure plasma and plasma activated water N Puač, N Škoro, K Spasić, S Živković, M Milutinović, G Malović, ... Plasma Processes and Polymers 15 (2), 1700082			37	2018
<input type="checkbox"/>	Plasma treated polyethylene terephthalate for increased embedment of UV-responsive microcapsules M Gorjanc, M Mozetič, G Primc, A Vesel, K Spasić, N Puač, ZL Petrović, ... Applied Surface Science 419, 224-234			24	2017
<input type="checkbox"/>	Biomedical applications and diagnostics of atmospheric pressure plasma ZL Petrović, N Puač, S Lazović, D Maletić, K Spasić, G Malović Journal of Physics: Conference Series 356 (1), 012001			16	2012
<input type="checkbox"/>	Plasma properties in a large-volume, cylindrical and asymmetric radio-frequency capacitively coupled industrial-prototype reactor S Lazović, N Puač, K Spasić, G Malović, U Cvelbar, M Mozetič, M Radetić, ... Journal of Physics D: Applied Physics 46 (7), 075201			6	2013
<input type="checkbox"/>	Application of fragrance microcapsules onto cotton fabric after treatment with oxygen and nitrogen plasma M Kert, P Forte Tavčer, A Hladnik, K Spasić, N Puač, ZL Petrović, ... Coatings 11 (10), 1181			4	2021
<input type="checkbox"/>	Measurements of atomic oxygen concentrations in a large scale asymmetric capacitively coupled plasma reactor by using catalytic probes S Lazović, N Puač, K Spasić, G Malović, U Cvelbar, M Mozetič, ... IPCIG 2011			2	2011
<input type="checkbox"/>	Development of biomedical applications of non-equilibrium plasmas and possibilities for atmospheric pressure nanotechnology applications ZL Petrović, N Puač, D Marić, D Maletić, K Spasić, N Škoro, J Sivoš, ... 2012 28th International Conference on Microelectronics Proceedings, 31-38			1	2012

Cited by

[VIEW ALL](#)

	All	Since 2017
Citations	147	127
h-index	5	4
i10-index	4	3

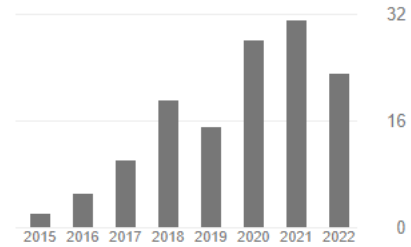

Public access

[VIEW ALL](#)



Based on funding mandates

Co-authors

[EDIT](#)

No co-authors

Bulletin of the American Physical Society

[Bulletin Home](#)
[My Scheduler](#)
[Epitome](#)
[Author Index](#)
[Session Index](#)
[Invited Speakers](#)
[Chair Index](#)
[Word Search](#)
[Affiliation Search](#)
[Using Scheduler](#)

64th Annual Gaseous Electronics Conference

Volume 56, Number 15

Monday–Friday, November 14–18, 2011; Salt Lake City, Utah

[Session QR1: Poster Session II: Plasma Appl. II; Charged Particle Collisions II; Plasma Sources II; Plasma Data Exchange Project; Plasma Diag. Tech. II; Plasma Modeling/Simulations II; Basic Plasma Phenomena II](#)

3:30 PM, Thursday, November 17, 2011

Room: Exhibit Hall AB

Abstract ID: BAPS.2011.GEC.QR1.77

Abstract: QR1.00077 : Catalytic probe measurements in a large scale CCP reactor*

[Preview Abstract](#)

[← Abstract →](#)

Authors:

Sasa Lazovic
(Institute of Physics, University of Belgrade, Serbia)

Kosta Spasic
(Institute of Physics, University of Belgrade, Serbia)

Nevena Puac
(Institute of Physics, University of Belgrade, Serbia)

Gordana Malovic
(Institute of Physics, University of Belgrade, Serbia)

Uros Cvelbar
(Jozef Stefan Institute, Ljubljana, Slovenia)

Miran Mozetic
(Jozef Stefan Institute, Ljubljana, Slovenia)

Zoran Lj. Petrovic
(Institute of Physics, University of Belgrade, Serbia)

A large scale cylindrical asymmetric CCP reactor is suitable for efficient treatment of materials like polymers, textile and plant seeds. Plasma is homogeneous and stable from transitions to streamers. For many biomedical and textile treatment effects, role of extremely reactive atomic oxygen species is very important. For instance, the formation of new oxygen-containing groups on the fiber surface is suggested to be due to the presence of extremely reactive atomic oxygen species in discharge during the air plasma processing and/or post-plasma chemical reactions when the activated fiber surface reacts with environmental species. Measurements were performed using nickel catalytic probe placed side-on to the powered electrode. Concentrations of neutral oxygen atoms were measured for a range of powers given by the RF generator, at several different distances from the powered electrode, in air at two different pressures. Oxygen atom concentrations coming to the surface of the samples can be controlled by adjusting the pressure, distance from the powered electrode and RF power.

*Projects III41011 and ON171037, MES Republic of Serbia

To cite this abstract, use the following reference: <http://meetings.aps.org/link/BAPS.2011.GEC.QR1.77>

Plasma properties in a large-volume, cylindrical and asymmetric radio-frequency capacitively coupled industrial-prototype reactor

This content has been downloaded from IOPscience. Please scroll down to see the full text.

2013 J. Phys. D: Appl. Phys. 46 075201

(<http://iopscience.iop.org/0022-3727/46/7/075201>)

View [the table of contents for this issue](#), or go to the [journal homepage](#) for more

Download details:

IP Address: 147.91.83.229

This content was downloaded on 16/05/2017 at 11:59

Please note that [terms and conditions apply](#).

You may also be interested in:

[Characterization and global modelling of low-pressure hydrogen-based RF plasmas suitable for surface cleaning processes](#)

Nikola Škoro, Nevena Pua, Saša Lazovi et al.

[Diagnostics and biomedical applications of radiofrequency plasmas](#)

Saša Lazovi

[Extremely non-equilibrium oxygen plasma for direct synthesis of metal oxide nanowires on metallic substrates](#)

Miran Mozetic

[Determination of the neutral oxygen atom density in a plasma reactor loaded with metal samples](#)

Miran Mozetic and Uros Cvelbar

[Characterization of an asymmetric parallel plate radio-frequency discharge using a retarding field energy analyzer](#)

D Gahan, S Daniels, C Hayden et al.

[Ion energy distribution measurements in rf and pulsed dc plasma discharges](#)

D Gahan, S Daniels, C Hayden et al.

[Application of extremely non-equilibrium plasmas in the processing of nano and biomedical materials](#)

Miran Mozeti, Gregor Primc, Alenka Vesel et al.

[Catalytic probes with nanostructured surface for gas/discharge diagnostics](#)

A Drenik, U Cvelbar, K Ostrikov et al.

Plasma properties in a large-volume, cylindrical and asymmetric radio-frequency capacitively coupled industrial-prototype reactor

Saša Lazović^{1,2}, Nevena Puač¹, Kosta Spasić¹, Gordana Malović¹,
Uroš Cvelbar², Miran Mozetič², Maja Radetić³ and Zoran Lj Petrović¹

¹ Institute of Physics, University of Belgrade, Pregrevica 118, Belgrade, Serbia

² Jožef Stefan Institute, Jamova cesta 39, 1000 Ljubljana, Slovenia

³ Faculty of Technology and Metallurgy, University of Belgrade, Karnegijeva 4, 11000 Belgrade, Serbia

E-mail: lazovic@ipb.ac.rs

Received 22 October 2012, in final form 10 December 2012

Published 23 January 2013

Online at stacks.iop.org/JPhysD/46/075201

Abstract

We have developed a large-volume low-pressure cylindrical plasma reactor with a size that matches industrial reactors for treatment of textiles. It was shown that it efficiently produces plasmas with only a small increase in power as compared with a similar reactor with 50 times smaller volume. Plasma generated at 13.56 MHz was stable from transition to streamers and capable of long-term continuous operation. An industrial-scale asymmetric cylindrical reactor of simple design and construction enabled good control over a wide range of active plasma species and ion concentrations. Detailed characterization of the discharge was performed using derivative, Langmuir and catalytic probes which enabled determination of the optimal sets of plasma parameters necessary for successful industry implementation and process control. Since neutral atomic oxygen plays a major role in many of the material processing applications, its spatial profile was measured using nickel catalytic probe over a wide range of plasma parameters. The spatial profiles show diffusion profiles with particle production close to the powered electrode and significant wall losses due to surface recombination. Oxygen atom densities range from 10^{19} m^{-3} near the powered electrode to 10^{17} m^{-3} near the wall. The concentrations of ions at the same time are changing from 10^{16} to the 10^{15} m^{-3} at the grounded chamber wall.

(Some figures may appear in colour only in the online journal)

1. Introduction

Low-temperature plasmas represent an irreplaceable tool for many industrial processes due to a variety of chemical reactions that can be induced and controlled, even at low gas temperatures. Most of the energy delivered to non-equilibrium plasmas is transferred to electrons and not to the heating of the background gas or walls of the vessel. Therefore, the electrons are determining the nature of chemical processes in the plasma as well as at the plasma-sample interfaces. Energetic electrons in plasma can produce active

species (ions, radicals, metastables and new electrons) in very high concentrations that can hardly be matched by traditional chemical or other methods. In addition, non-equilibrium plasmas may be easily modified and controlled by changing the composition, pressure, current density and flow, thus allowing a wide range of variation of a number of parameters and allowing optimization and even on-line control of some technological plasma based processes.

However, the interaction between the plasma created active species and the substrate is also depending on the material properties of the substrate. Intrinsic surface properties

and desired treatment effects are setting the requirements for the plasma source design, defining the range of applicable internal and external plasma parameters. From the point of practical use, the crucial aim is to determine the optimal range of applicable plasma parameters and proper plasma operating regime [1–5]. Controllable plasma chemical reactions are widely used in the processing of materials of different origins and properties [6, 7]. For example, field of microelectronics is strongly influenced by the development of plasma devices, i.e. by improved results on plasma deposition, etching, ashing, implantation, surface cleaning and other surface modification processes [8, 9]. Another rapidly growing research field is biomedical plasma applications [10–13]. Related to this, low-pressure plasmas also find their place in the sterilization of medical instruments, processing of biocompatible materials and, for example, in increasing antibacterial properties of textiles later used in medical, military or food preparation purposes. While it was expected that atmospheric pressure plasmas would replace the low-pressure reactors, the complexity of vacuum system is replaced by other complexities, such as small gap, instability of operation and usage of helium as a buffer gas [14, 15]. Thus, low pressure plasmas are still an option for applications of materials and samples that can be placed in vacuum.

In order to measure plasma parameters and effectively control the plasma process, we need to apply different diagnostic techniques. Typically, we are looking for quantitative results which can be monitored as an indication of the plasma processing and also in order to compare with models that are required to understand plasmas, to optimize the equipment and even to control processing in real time.

Several methods have been developed for measurement of neutral atom density. The mass spectroscopy is suitable as long as plasma is created at low pressures; however, in many plasmas partial pressure may be as high as 100 Pa [16, 17]. For these cases and the cases of atmospheric pressure discharges, differential pumping of the mass spectrometer is obligatory, which significantly increases the cost of the technique and introduces some problems [18]. A similar problem occurs when measuring plasma ions. In any case, mass spectrometry, while providing detailed results, has a limitation due to difficulty in making absolute calibration. Chemical titration using NO is a reliable method, but it tends to be time consuming and destructive so it is not suitable for real time measurements [19, 20]. Laser absorption spectroscopy such as laser-induced fluorescence (LIF), two-photon laser-induced fluorescence (TALIF) [21] or cavity ring-down spectroscopy (CRDS) [22] are reliable methods, but require expensive equipment and are therefore of little interest for industry. On the other hand, optical emission spectroscopy (OES) is easy to use; it requires inexpensive equipment and allows real time measurements. Nevertheless it is still nowadays regarded as semi-qualitative since quantification of the results is difficult (see [23]).

Catalytic probes are simple, easy to use and allow real-time monitoring of the neutral atom density as long as the neutral gas temperature is close to the room temperature, and the dissociation fraction is many orders of magnitude larger than the ionization fraction [24]. Until now, catalytic

probes were used to measure atomic oxygen species in inductively coupled radiofrequency and microwave discharges [25, 26]. Some measurements were also performed in capacitively coupled radiofrequency plan parallel reactors [27–29]. Reports show that atomic oxygen concentrations are of the order of 10^{21} m^{-3} except for the capacitively coupled plasma (CCP) reactor where densities are lower, 10^{19} m^{-3} .

In this paper we apply several diagnostic techniques to study plasma of a large-scale asymmetric capacitive plasma reactor. We have developed an industrial reactor of a simple design where homogeneous, stable plasma capable of long term operation is generated. The main objective was to limit the energy of the ions bombarding the sample surfaces while still having sufficient densities of active plasma species.

The large size reactor was built to demonstrate the properties of plasma of a large size that can reasonably handle on-line textile treatment. This would require an additional differential pumping stage so that the textile would be introduced through a slit at one side of the reactor wall, continuously moved through the plasma and finally the treated textile would be rolled after exiting. Additionally, the intensity of the treatment can also be controlled by adjusting the distance between the power electrode and the samples. Our previous studies of plasma treatment of textile [30] were carried out in a similar asymmetric reactor of a much smaller volume. In this paper, we present results on characterization of the large volume plasma. Langmuir and catalytic probes were used to measure spatial profiles of concentration of ions and of atomic oxygen. Detailed electrical characterization of the reactor was performed using home-made derivative probes which proved to be superior to commercial probes and power meters, overcoming problems with operating frequency ranges and calibration. The current–voltage characteristics of the discharge, as well as, the real power delivered to the plasma by the generator will be presented. All measurements were carried out in air plasma for several different pressures and powers.

The ion energies and concentrations can be independently controlled using two RF sources operating at different frequencies [31, 32], but due to simplicity and reduced cost, we have chosen asymmetrical (cylindrical) geometry of the reactor [33]. This asymmetry provides a very large ratio of areas of the grounded to the powered electrode and consequently pronounced differences between voltage drops in the sheaths. This leads to differences in energies of ions bombarding the two electrodes. In addition, relatively large atomic oxygen densities are present. Oxygen atoms are necessary for plasma modification of seeds, polymers and textiles [34–37] for which the reactor was already used, as well as, many other treatments. However, a detailed characterization of plasma species, especially of ions, neutral atoms as well as proper input powers, is not yet available including correlations between those species and plasma properties. One of the most common problems in microelectronic manufacturing [38] is temporal variation of plasma properties due to modification of surfaces of the vessel. We have thus developed a simple real time monitoring plasma processes based on the catalytic probes that may be easily applied in large-scale industrial processes.

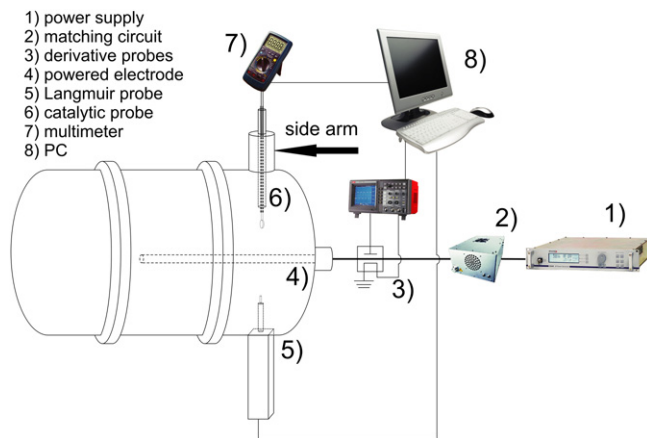

Figure 1. Schematics of the experimental setup.

2. Experimental setup

A CCP reactor powered at 13.56 MHz and operated at low pressures with a large volume in which uniform plasma can be created was used for experiments. The discharge chamber made of stainless steel was 2.5 m long and 1.17 m in diameter. The powered electrode was 1.5 m long (and could be extended to fully 2.5 m), 3 cm in diameter and made of aluminum. It is placed axially at the centre of the chamber. The chamber has a platform at the bottom where samples can be placed. The distance between the platform and the powered electrode is adjustable by moving the platform. The outer chamber wall is the grounded electrode and the sample platform is grounded as well.

The electrical circuit consists of an RF power generator Dressler Cesar 1310 in combination with Variomatch matching network. Derivative probes were placed as close as possible to the powered electrode. Langmuir and catalytic probe were placed side-on to the reactor wall (as presented in figure 1). The reduced pressure is maintained using a two-stage rotary pump ($60 \text{ m}^3 \text{ h}^{-1}$). Ambient air is introduced into the chamber through a needle valve.

In the regime with flowing working gas, the pumping system can also affect the way atomic oxygen recombines at the catalytic probe surface [39]. Due to this reason, we measured densities in both fluent and stationary regime, with and without pumping. Our results showed that in the present setup the effect of pumping on results was negligible.

Knowledge of power introduced into the plasma is essential in characterizing plasmas and controlling operating conditions in plasma processing. Non-linear impedance of the plasma imposes harmonics of the drive frequency. Asymmetry of the discharge chamber also affects the way harmonics are generated. Due to this non-linearity, the change in external circuitry leads to unpredictable variation of the plasma properties. For example, the auto-tune feature on the matching network can result in different reflected power minima for several apparently identical measurements which will result in different values of power deposited into the plasma [40]. Therefore, the power measured at the RF generator is not the best parameter.

Disadvantages of using commercial power meters lie in the fact that the power is usually measured only at a single frequency or in a very narrow range of frequencies, thus leaving out the information about power delivered to the load at the frequencies of the higher harmonics. There are also commercial probes available for current and voltage measurements at radio frequencies but their disadvantage is that in most of the cases their frequency response is not characterized properly. Derivative probes which are calibrated in a wide range of frequencies (from an order of magnitude lower to an order of magnitude higher) overcome these problems. Such probes can be placed close to the powered electrode reducing the error introduced by the losses in the part of external electrical circuit from the probes to the powered electrode. We have used previously described derivative probes [41] in order to measure the power transmitted to the plasma and analyse harmonic composition of the signals.

Both probes were placed into a stainless steel box opposite each other and as close as possible to the powered electrode. Instantaneous voltages and currents were monitored using derivative probes which were connected to the oscilloscope with cables of identical length (so there would be no additional phase differences between current and voltage signals introduced). All waveforms were collected by the computer for further analysis. Numerical processing of the acquired data consists of a fast Fourier transform (FFT), calibration in the frequency domain of both amplitude and phase and inverse fast Fourier transform (IFFT) after which the real calibrated waveforms are obtained. Measurements using derivative probes were carried out for the whole range of powers delivered by the RF generator. Before every measurement reflected power was checked and, if needed, adjusted to be less than 1% of the forward power.

Spatial profiles of the ion concentrations were measured using Hiden Analytical ESPION advanced Langmuir probe system which was placed side-on. The system has a linear motion drive which enables probe positioning with the minimal spatial resolution of 0.1 mm. Measurements were made in air at 100 mTorr. We have used a platinum probe tip, 5 mm long and 0.15 mm in diameter. Linear motion drive was used to position the probe at distances from 50.5 to 20.5 cm measured from the powered electrode. Measurements of $V-I$ curves were made for all those positions of the Langmuir probe. At every position 50 measurements were made each consisting on average of 10 scans with pre-cleaning for each measurement. Afterwards, the $V-I$ curves were smoothed and data were processed using HidenESPSOft. Orbit motion-limited theory implemented in the standard HIDDEN ESPion software was applied. Mass of N_2^+ ion was assumed in the analysis thus giving an effective density where contributions of other ions are projected onto that of N_2^+ .

Spatial profiles of the neutral oxygen atoms were measured using nickel catalytic probe (polycrystalline nickel disc with purity $\sim 99.8\%$). The probe covered the same distances from the powered electrode where the ion concentrations were measured. The catalytic probe was moved even further away from the powered electrode than the reactor

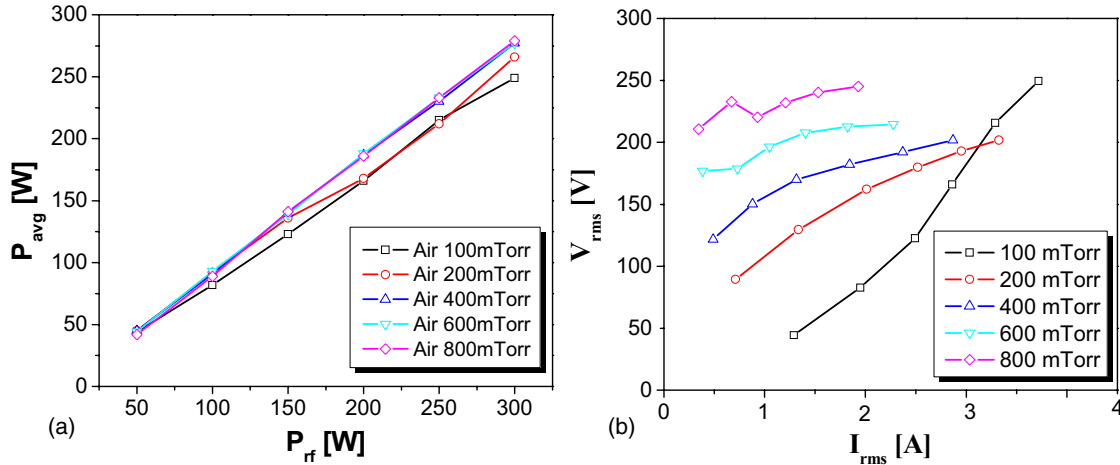

Figure 2. (a) Average power delivered to the plasma measured by derivative probes (P_{avg}) as a function of power given by the RF generator (P_{rf}). (b) Volt–ampere characteristics of the discharge measured by derivative probes. Gas was air at 100, 200, 400, 600 and 800 mTorr.

walls. Namely, it was necessary to mount a cylindrical, stainless steel, side chamber (arm) which is perpendicular to the chamber wall in order to mount the probe and allow its movement. The chamber wall is 57.5 cm away from the electrode, and the catalytic probe was moved up to 6 cm inside the side tube. Measurements of oxygen concentrations were extended into the reactor side arm.

The asymmetry of the reactor introduces large differences in ion energies and fluxes near the powered electrode and near the grounded chamber wall due to different values of sheath potential drops:

$$\left(\frac{U_p}{U_g}\right) = \left(\frac{A_g}{A_p}\right)^k, \quad (1)$$

where U_p and U_g are sheath voltages and A_p and A_g are the areas of powered and grounded electrodes, respectively. Theoretically, k ranges from 1.25 to 4, and experimentally it is less than 2.5 [42]. The smaller the electrode area, the smaller is its capacitance, and therefore the corresponding potential drop is larger. On the other hand, the sheath thickness, which will also affect the capacitance and the voltage drops, may depend on the voltage across it, through Child’s law. The problem needs to be solved self-consistently to obtain the voltages [43]. Pronounced gradients of ion energies and concentration appear at different distances from the powered electrode in our reactor. Therefore, the position of the substrate or the measuring probe will strongly affect the intensity of the positive ion bombardment of the substrate surface. The highest flux of ions and the highest energies will be associated with the bombardment of the smaller electrode (1) [42, 44].

3. Results and discussion

3.1. Electrical characterization of the reactor: power measurements and current–voltage characteristics

We first recorded current and voltage waveforms and then calculated the mean power as the time integral of their product. Dependence of the average power, measured by the derivative probes, on the power produced by the RF generator in air

for several pressures is given in figure 2(a). We can see that the dependence is linear and that most of the power is indeed delivered to the reactor. With the changing of pressure, the delivered power does not change significantly. The discrepancy increases with an increase in the power.

From the volt–ampere (V–A) characteristics shown in figure 2(b) we can conclude that the plasma is operating in the α regime judged by the almost linear V–A dependence. The differential impedance magnitude is decreasing with an increase in pressure (from 100 Ω down to 30 Ω). We can also see that the root mean square values (rms) of voltage are ranging from about 50 up to 250 V and that working voltages are increased with an increase in pressure of the working gas. On the other hand, rms values of current are decreased with an increase in the pressure, remaining in the range from 0.2 to 3.8 A.

As mentioned above, the dimensions of the reactor were selected to be such that it could accommodate processing of a standard width of the textile as used in the industry. It turned out that it was possible to achieve uniformity over the entire width of the textile and stable operation for hours without any sparking that often occurs at atmospheric pressure. Our experimental device that was used in our previous studies of textile treatment [30, 34, 35, 45] had 0.37 m diameter and length of 0.5 m. Thus, its volume is about 50 times smaller than the volume of the large size reactor. Nevertheless the large volume reactor was able to provide the same level of treatment of the surface with only an increase in 30–50% in power.

3.2. Influence of ion bombardment on heating of the catalytic probe and samples

There are two major reasons for performing Langmuir probe measurements in the main reactor chamber. The first one is to establish the flux of ions which determines the basic effect but if allowed to be excessive may damage the sample. Secondly, we need to estimate the contribution of ion bombardment to the heating of the catalytic probe. For that purpose we have measured spatial profiles in air at 100 mTorr at different

distances from the powered electrode. Ion bombardment, light quanta, radiation, accommodation of gaseous molecules, relaxation of metastable oxygen and ion recombination can significantly contribute to the heating of the probe, depending on the type of the discharge and operating conditions.

If we assume that the heating of the probe is only due to recombination of atomic oxygen and ion bombardment, then the heat dissipated at the probe surface is given by

$$P_{\text{heat}} = P_O + P_i = j_O \gamma W_d \pi r^2 + j_i W_i \pi r^2 \quad (2)$$

where P_O is the contribution due to the neutral oxygen atom recombination, P_i is the ion bombardment term, j_O is the neutral oxygen atom flux and j_i is the ion flux, γ is the coefficient for heterogeneous surface recombination of O atoms on the nickel surface with the value of 0.27 [46], W_d and W_i are the dissociation and first ionization energy of oxygen molecules and r is the nickel probe disc radius. Here, it is worth noting that our discharge is created in air, which can also produce neutral nitrogen atoms and other species including metastables. However, one should have in mind that the dissociation energy of N_2 is 9.75 eV, as compared with 5.12 eV for O_2 . Additionally, the recombination coefficient for N atoms is also lower and is 0.1. Due to this reason, the dissociation of O molecules with dissociation energy of 5.12 eV is the most probable channel, and contributions of N atoms can be neglected in first approximation.

Neutral oxygen atom flux and ion flux are then given by

$$j_O = \frac{1}{4} n_O v_O; \quad j_i = n_i v_i, \quad (3)$$

where n_O and n_i are the O atom and ion density, in the probe vicinity, respectively. v_O is the average of the absolute value of thermal velocity of O atoms, v_i is the Bohm velocity. The probe is being heated until the temperature saturates and then the discharge is turned off. At this moment heating and cooling rates of the probe are equal. The cooling rate is given by

$$P = m c_p \frac{\Delta T}{\Delta t}, \quad (4)$$

where m is the nickel disc mass, c_p its specific thermal capacity and $\Delta T/\Delta t$ is the absolute value of the temperature derivative just after turning off the discharge. It is important to note that by equating the heating and the cooling terms and taking into account only the neutral atom contribution, the concentrations are calculated as follows:

$$n = \frac{4mC_p}{\nu\gamma W_d \pi r^2} \frac{\Delta T}{\Delta t}. \quad (5)$$

Another important fact is that from the ratio of $j_i W_i / j_O \gamma W_d$ we can calculate the upper limit for the ion contribution to the heating of the electrode. The ion contribution to the energy of the electrode W_i is the sum of the kinetic energy which is gained in the sheaths and the ionization energy (the first ionization energy for O_2 molecule is 12 eV) [27]. Obviously, the ion kinetic energy in a strongly asymmetric discharge of this kind is going to be significantly different at different distances from the powered electrode, as mentioned before (1). From figures 3 and 4, we can see that the

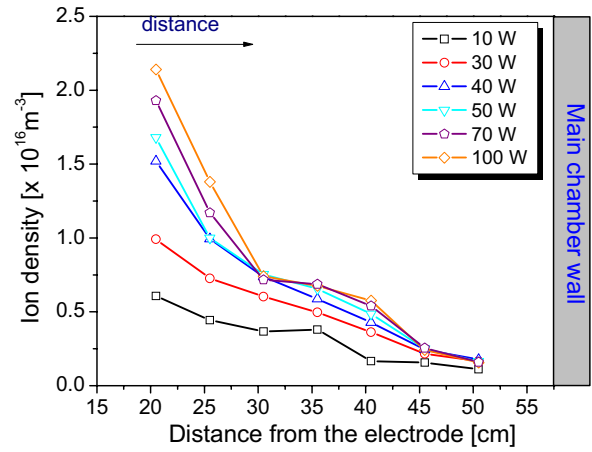

Figure 3. Spatial profiles of ions measured by the Langmuir probe in air at 100 mTorr and at different powers.

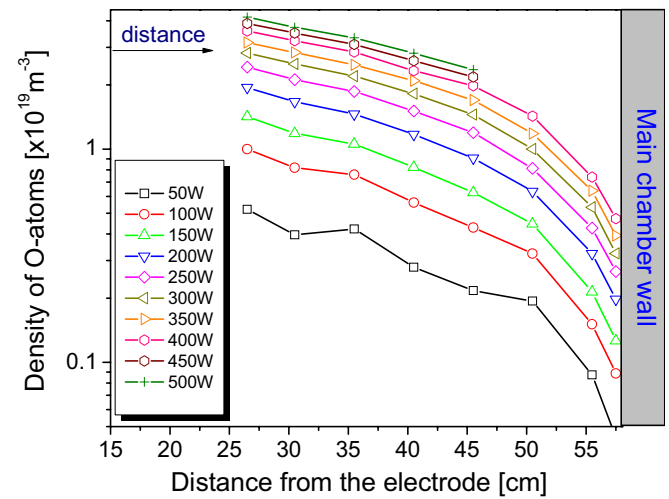

Figure 4. Concentrations of oxygen atoms measured by the catalytic probe in air at 100 mTorr at different powers.

ion concentrations are three orders of magnitude lower than the measured neutral atomic oxygen concentrations for low generator powers up to 100 W. We were not able to conduct proper Langmuir probe measurements for higher powers due to additional secondary discharge developing at the tip of the probe influencing our results, but we expect the same ratio to be maintained for powers higher than 100 W.

Ion measurements were performed in air plasma at 100 mTorr and at distances from the powered electrode of 20.5 cm up to 50.5 cm. Measured ion densities are between 10^{15} and 10^{16} m^{-3} (figure 3), whereas concentrations of neutral oxygen atoms were of the order of 10^{18} – 10^{19} m^{-3} (figure 4). Ion and atomic oxygen concentrations are typically decreasing with the distance from the powered electrode, and increasing with the power.

Recombination coefficient of nickel is 0.27 for neutral atomic oxygen recombination while almost every ion (for example O^+ , N^+ , N_2^+ , O_2^+ , NO^+) reaching the probe surface recombines with probability 100% and contributes to the probe's heating. In the case of the symmetric CCP, the authors report that the ion contribution is about 2%, when

taking W_i to be 12 eV + 18 eV [26]. Having in mind that in the region close to the grounded electrode of the asymmetric CCP, the ion energies are lower than 18 eV [30], we can conclude that the contribution to heating of the catalytic probe due to ions is even lower than for the symmetric CCP. More precisely, the upper limit to the contribution to heating of the catalytic probe surface due to ions in our case ranges from 1.2% to 2%, as previously estimated. Unfortunately, due to the limited length of the catalytic probe we were not able to go very close to the powered electrode.

From the above results we can conclude that in our experiments the ion contribution to the heating of the catalytic probe surface is not substantial. In the same light, we can see that close to the main chamber wall neither ion energies (1) nor ion concentrations (see figure 3) are high and that the wall represents a drain for both species.

3.3. Radial dependence of atomic oxygen in cylindrical chamber and chamber extension

The dependence of oxygen atom densities with the distance from the powered electrode is influenced by the balance of production and losses. Having in mind cylindrical geometry of the reactor, atomic oxygen is produced in the plasma at close proximity to the powered electrode, while on the other hand recombination takes place predominantly at the surface of reactor walls. Atom recombination at the probe surface may, amongst other things, be affected by the vicinity and area of the reactor walls in the main chamber and the side tube.

The spatial profiles of oxygen atom densities in the main reactor and in the side arm are shown in figure 5. We cannot guarantee whether the reading of the atom density at the position of the chamber wall is the same as it is at the wall where there is neither side arm nor catalytic probe. Nevertheless the profiles are consistent with diffusion profiles with a small but appreciable reflection. As expected, at lower pressures the density is lower which is consistent with a longer mean free path.

The densities in the small tube continue decreasing but faster than in the main chamber. This is consistent with increased losses due to smaller size vessel and larger probability of reaching the walls. The observed profiles offer a possibility to control fluxes of reactive particles by placing samples at different distances from the powered electrode, even placing them inside the sidearm.

4. Conclusion

Plasma behaviour was studied in a large-volume (2.6 m^3) asymmetric CCP (industrial prototype) reactor of a simple design (with a side arm that is needed to mount probes). Two key properties of plasma for application in textile treatment, densities of ions (physical sputtering and damage to the surface) and oxygen atoms (chemical functionalization of surfaces) and electrical characteristics were measured. The wetting time achieved by this system was dramatically reduced. Since the wetting time after plasma treatment is extremely short and difficult to measure, we could not quantify these results,

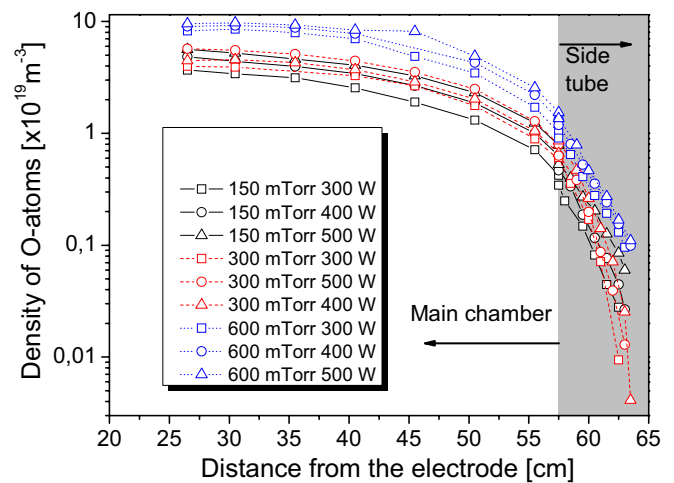

Figure 5. Spatial profiles of oxygen atoms measured by the catalytic probe in air in the main reactor vessel and in the side arm (tube positioned perpendicular to the chamber wall) in which the probe is mounted (the main chamber wall distance from the powered electrode is 57.5 cm). Measurements were made at different powers and gas pressures.

i.e. we could not compare the two treated samples. Although, we can state that the reduction in wetting time is similar and causes very fast wetting of the samples whereas plasma non-treated samples are very hydrophobic and water as well as dye solution does not penetrate the textile. Size of the reactor would allow continuous treatment of textile from the rolls of the standard width used in the industry.

Derivative probes used for electrical characterization of the reactor and plasma power measurement proved to provide reliable results. We found that our plasma operates in alpha mode and most of the generated power is dissipated inside the plasma [47]. Due to reactor design and its cylindrical asymmetric geometry, spatial distributions of ions and atomic oxygen are changing significantly as we move away from the powered electrode. Langmuir probe was used to measure the spatial profiles of ion densities in order to make sure that samples will not be damaged by ion bombardment and to calculate the ion contribution to the heating of the catalytic probe. Ion densities were of the order of 10^{16} m^{-3} . A nickel catalytic probe was used to measure the spatial profiles of atomic oxygen in air for a wide range of pressures. It is determined that in the main reactor vessel the atomic oxygen densities are of the order of 10^{19} m^{-3} and are almost linearly decreasing as we move away from the powered electrode. In the small side reactor the densities are 10^{18} m^{-3} or even 10^{17} m^{-3} depending on the proximity to the walls and pressure. Therefore, there is a wide range of atomic oxygen concentrations which can be delivered to the samples based on the position of treated material, inside the main vessel or perpendicular side arm. The results indicate that the diffusion is the mechanism governing profiles of neutral atoms. Atomic oxygen loss processes are dominantly affected by the recombination of atoms at the vessel/tube walls. Taking into account the power measured by the derivative probes, spatial profiles of ion densities measured by the Langmuir probe and spatial profiles of atomic oxygen optimal set of

important plasma parameters can be obtained for optimization of sensitive material treatment according to required flux of ions or atoms to its surface. It is shown that high atomic density can be achieved even for lower powers, and therefore lower processing costs, by placing the sample close to the powered electrode but in that case one has to deal with somewhat higher ion energies.

Compared with other plasma sources investigated by the catalytic probes (MW and ICP for example) here we have two to four orders of magnitude lower oxygen atom densities due to its large size and smaller volume where the atoms are produced [48]. This property makes the cylindrical reactor appropriate for treatment of sensitive samples such as seeds, polymers and textile. The primary reason for the low measured densities is the distance from the powered electrode and a very large volume. At the same time one may select the geometry and position of the sample to control the fluxes. The energy of ions may also be controlled by selecting position (1) and also by biasing.

Acknowledgments

This research is sponsored by the Ministry of Education and Science, Republic of Serbia, project no OI 171037 and III 41011, Slovenian Research Agency (ARRS) and Slovenian Human Resources Development and Scholarship Fund (AdFutura). This paper has also been facilitated by the bilateral programme of scientific cooperation between Slovenia and Serbia.

References

- [1] Fridman A and Kennedy L A 2004 *Plasma Physics and Engineering* (New York: Taylor and Francis)
- [2] Mahony C M O, Maguire P D and Graham W G 2005 Electrical characterization of radio frequency discharges *Plasma Sources Sci. Technol.* **14** S60–7
- [3] Godyak V A 2011 Electrical and plasma parameters of ICP with high coupling efficiency *Plasma Sources Sci. Technol.* **20** 025004
- [4] Kieft I E, Laan E P v d and Stoffels E 2004 Electrical and optical characterization of the plasma needle *New J. Phys.* **6** 149–63
- [5] Gahan D, Daniels S, Hayden C, Scullin P, O'Sullivan D, Pei Y T and Hopkins M B 2012 Ion energy distribution measurements in rf and pulsed dc plasma discharges *Plasma Sources Sci. Technol.* **21** 024004
- [6] Makabe T and Yagisawa T 2011 Low-pressure nonequilibrium plasma for a top-down nanoprocess *Plasma Sources Sci. Technol.* **20** 024011
- [7] Roth C, Oberbossel G and Rudolf von Rohr P 2012 Electron temperature, ion density and energy influx measurements in a tubular plasma reactor for powder surface modification *J. Phys. D: Appl. Phys.* **45** 355202
- [8] Chen F F and Chang J P 2003 *Lecture Notes on Principles of Plasma Processing* (Dordrecht/New York: Kluwer/Plenum)
- [9] Makabe T and Petrović Z L 2006 *Plasma Electronics: Applications in Microelectronic Device Fabrication* (New York: Taylor and Francis)
- [10] Dobrynin D, Fridman G, Friedman G and Fridman A 2009 Physical and biological mechanisms of direct plasma interaction with living tissue *New J. Phys.* **11** 115020
- [11] Kong M G, Kroesen G, Morfill G, Nosenko T, Shimizu T, van Dijk J and Zimmermann J L 2009 Plasma medicine: an introductory review *New J. Phys.* **11** 115012
- [12] Lazović S *et al* 2010 The effect of a plasma needle on bacteria in planktonic samples and on peripheral blood mesenchymal stem cells *New J. Phys.* **12** 083037
- [13] Petrović Z L, Puač N, Lazović S, Maletić D, Spasić K and Malović G 2012 Biomedical applications and diagnostics of atmospheric pressure plasma *J. Phys.: Conf. Ser.* **356** 012001
- [14] Puač N, Maletić D, Lazović S, Malović G, Đorđević A and Petrović Z L 2012 Time resolved optical emission images of an atmospheric pressure plasma jet with transparent electrodes *Appl. Phys. Lett.* **101** 024103
- [15] Stefanović I, Kusche T, Škoro N, Marić D, Petrović Z L and Winter J 2011 Oscillation modes of direct current microdischarges with parallel-plate geometry *J. Appl. Phys.* **110** 083310
- [16] Ferreira J A and Tabarés F L 2007 Cryotrapping assisted mass spectrometry for the analysis of complex gas mixtures *J. Vac. Sci. Technol. A* **25** 246
- [17] Gaboriau F, Cartry G, Peignon M-C and Cardinaud C 2006 Etching mechanisms of Si and SiO₂ in fluorocarbon ICP plasmas: analysis of the plasma by mass spectrometry, Langmuir probe and optical emission spectroscopy *J. Phys. D: Appl. Phys.* **39** 1830–45
- [18] Malović G, Puač N, Lazović S and Petrović Z 2010 Mass analysis of an atmospheric pressure plasma needle discharge *Plasma Sources Sci. Technol.* **19** 034014
- [19] Mozetič M, Ricard A, Babić D, Poberaj I, Levaton J, Monna V and Cvelbar U 2003 Comparison of NO titration and fiber optics catalytic probes for determination of neutral oxygen atom concentration in plasmas and postglows *J. Vac. Sci. Technol. A* **21** 369
- [20] Mozetič M, Cvelbar U, Vesel A, Ricard A, Babić D and Poberaj I 2005 A diagnostic method for real-time measurements of the density of nitrogen atoms in the postglow of an Ar–N₂ discharge using a catalytic probe *J. Appl. Phys.* **97** 103308
- [21] Gaboriau F, Cvelbar U, Mozetič M, Erradi A and Rouffet B 2009 Comparison of TALIF and catalytic probes for the determination of nitrogen atom density in a nitrogen plasma afterglow *J. Phys. D: Appl. Phys.* **42** 055204
- [22] Labazan I and Milošević S 2004 Determination of electron density in a laser-induced lithium plume using cavity ring-down spectroscopy *J. Phys. D: Appl. Phys.* **37** 2975–80
- [23] Makabe T and Petrović Z L 2002 Development of optical computerized tomography in capacitively coupled plasmas and inductively coupled plasmas for plasma etching *Appl. Surf. Sci.* **192** 88–114
- [24] Drenik A C U, Vesel A and Mozetič M 2005 *Inform. MIDE M* **35** 85
- [25] Mozetič M, Vesel A, Cvelbar U and Ricard A 2006 An iron catalytic probe for determination of the O-atom density in an Ar/O₂ afterglow *Plasma Chem. Plasma Process.* **26** 103–17
- [26] Primc G, Zaplotnik R, Vesel A and Mozetič M 2011 Microwave discharge as a remote source of neutral oxygen atoms *AIP Adv.* **1** 022129
- [27] Vrlinić T, Mille C, Debarnot D and Poncin-Epaillard F 2009 Oxygen atom density in capacitively coupled RF oxygen plasma *Vacuum* **83** 792–6
- [28] Gomez S, Steen P G and Graham W G 2002 Atomic oxygen surface loss coefficient measurements in a capacitive/inductive radio-frequency plasma *Appl. Phys. Lett.* **81** 19

- [29] Kitajima T, Noro K, Nakano T and Makabe T 2004 Influence of driving frequency on oxygen atom density in O₂ radio frequency capacitively coupled plasma *J. Phys. D: Appl. Phys.* **37** 2670–6
- [30] Puač N, Petrović Z L, Radetić M and Djordjević A 2005 Low pressure RF capacitively coupled plasma reactor for modification of seeds, polymers and textile fabrics *Mater. Sci. Forum* **494** 291–6
- [31] Kitajima T, Takeo Y, Nakano N and Makabe T 1998 Effects of frequency on the two-dimensional structure of capacitively coupled plasma in Ar *J. Appl. Phys.* **84** 5928
- [32] Kitajima T, Takeo Y, Petrović Z L and Makabe T 2000 Functional separation of biasing and sustaining voltages in two-frequency capacitively coupled plasma *Appl. Phys. Lett.* **77** 489
- [33] Gahan D, Daniels S, Hayden C, Sullivan D O and Hopkins M B 2012 Characterization of an asymmetric parallel plate radio-frequency discharge using a retarding field energy analyzer *Plasma Sources Sci. Technol.* **21** 015002
- [34] Ilić V, Šaponjić Z, Vodnik V, Lazović S, Dimitrijević S, Jovančić P, Nedeljković J M and Radetić M 2010 Bactericidal efficiency of silver nanoparticles deposited onto radio frequency plasma pretreated polyester fabrics *Indust. Eng. Chem. Res.* **49** 7287–93
- [35] Mihailović D, Šaponjić Z, Radoičić M, Lazović S, Baily C J, Jovančić P, Nedeljković J and Radetić M 2011 Functionalization of cotton fabrics with corona/air RF plasma and colloidal TiO₂ nanoparticles *Cellulose* **18** 811–25
- [36] Živković S, Puač N, Giba Z, Grubišić D and Petrović Z L 2004 The stimulatory effect of non-equilibrium (low temperature) air plasma pretreatment on light-induced germination of *Paulownia tomentosa* seeds *Seed Sci. Technol.* **32** 693–701
- [37] Morent R, De Geyter N, Verschuren J, De Clerck K, Kiekens P and Leys C 2008 Non-thermal plasma treatment of textiles *Surf. Coat. Technol.* **202** 3427–49
- [38] Hrunski D, Grählert W, Beese H, Kilper T, Gordijn a and Appenzeller W 2009 Control of plasma process instabilities during thin silicon film deposition *Thin Solid Films* **517** 4188–91
- [39] Cvelbar U, Mozetič M, Babič D, Poberaj I and Ricard A 2006 Influence of effective pumping speed on oxygen atom density in a plasma post-glow reactor *Vacuum* **80** 904–7
- [40] Miller P A, Anderson H and Splichal M P 1992 Electrical isolation of radiofrequency plasma discharges *J. Appl. Phys.* **71** 1171–6
- [41] Puač N, Petrović Z, Živković S, Giba Z, Grubišić D and Đorđević A 2005 *Plasma Processes and Polymers* ed R d'Agostino *et al* (Weinheim: Wiley)
- [42] Koenig H R and Maissel L I 1970 Application of Rf discharges to sputtering *IBM J. Res. Dev.* **14** 168–71
- [43] Lieberman M A and Lichtenberg A J 2005 *Principles of Plasma Discharge and Materials Processing* (Hoboken, NJ: Wiley)
- [44] d'Agostino R, Favia P and Fracassi F 1997 *Plasma Processing and Polymers* vol 346 (Dordrecht: Kluwer)
- [45] Gorenšek M, Gorjanc M, Bukošek V, Kovač J, Petrović Z and Puač N 2010 Functionalization of Polyester Fabric by Ar/N₂ Plasma and Silver *Textile Res. J.* **80** 1633–42
- [46] Šorli I and Ročak R 2000 Determination of atomic oxygen density with a nickel catalytic probe *J. Vac. Sci. Technol. A* **18** 338
- [47] Savić M, Radmilović Radenović M, Šuvakov M, Marjanović S, Marić D and Petrović Z L 2011 On explanation of the double-valued Paschen-like curve for RF breakdown in argon *IEEE Trans. Plasma Sci.* **39** 2556–7
- [48] Balat-Pichelin M and Vesel A 2006 Neutral oxygen atom density in the MESOX air plasma solar furnace facility *Chem. Phys.* **327** 112–8

FULL PAPER

Activity of catalase enzyme in *Paulownia tomentosa* seeds during the process of germination after treatments with low pressure plasma and plasma activated water

Nevena Puač¹  | Nikola Škoro¹ | Kosta Spasić¹ | Suzana Živković² |
Milica Milutinović² | Gordana Malović¹ | Zoran Lj. Petrović^{1,3}

¹ Institute of Physics, University of Belgrade, Pregrevica 118, 11080 Belgrade, Serbia

² Institute for Biological Research “Siniša Stanković”, University of Belgrade, Bulevar despota Stefana 142, 11060 Belgrade, Serbia

³ Serbian Academy of Sciences and Arts, Knez Mihailova 35, 11000 Belgrade, Serbia

Correspondence

Institute of Physics, University of Belgrade, Pregrevica 118, 11080 Belgrade, Serbia.
Email: nevena@ipb.ac.rs

In this work we present results of two significantly different types of plasma treatment on *Paulownia tomentosa* Steud. seeds. In the first type, seeds were directly treated in low-pressure plasma and then imbibed with distilled water. In the second type, an atmospheric pressure plasma was used for obtaining plasma activated water (PAW) which is then used for imbibition of seeds. The CAT activity and protein content is evaluated during 4 d following the imbibition process, i.e., immediately after the phytochrome activation and in the 3 subsequent days. Comparison of results of treated seeds to the control group allows to correlate the enzyme activity and protein content during the initial stages of germination with plasma treatment types and treatment conditions.

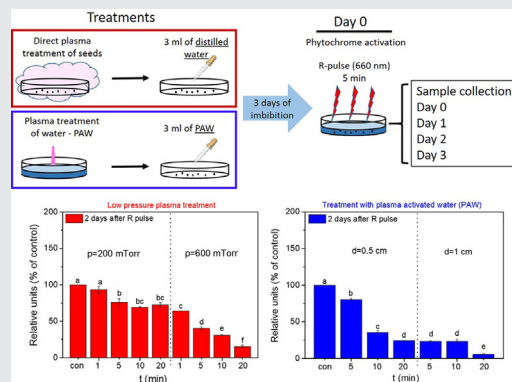

KEYWORDS

catalase, non-equilibrium plasma, plasma activated water, seed germination

1 | INTRODUCTION

Non-equilibrium plasmas for decades played an important role in treatments of various types of materials in order to modify roughness, hydrophobicity, produce coatings, polymerization, nanostructuring, increase the active area for absorbed dyes on textile surface, etc.^[1–6] The choice which plasma system will be used is determined mainly by the type of the sample and the effect that plasma needs to achieve.

Another very important point in favor of plasmas is that they are environmentally friendly and, in most cases, cost efficient solutions that can supplement or replace in total classical treatments. Lately, the driving force for development of plasma sources, especially those that operate at atmospheric pressure, is the expansion of biomedical applications of plasmas. Low temperature plasmas so far have been successfully used for sterilization, wound healing, blood coagulation, cancer treatment, increasing of differentiation,

and proliferation of normal and human stem cells, stomatology, dermatology, and treatment/production of biocompatible materials.^[7–14] Applications of these devices is accompanied by their detailed characterization by various diagnostic techniques^[5,15,16] as well as comprehensive modeling that describe plasma behavior and chemistry, especially chemistry of reactive oxygen and nitrogen species (RONS) production that have key importance in biomedical applications.^[4,17–24]

In recent times, new and fast developing field of low temperature plasma applications is plasma agriculture (application of plasmas for different aspects of agriculture and food industry). It was shown that both low pressure and atmospheric pressure plasmas can be successfully used in stimulation of seed growth, increase of germination percentage and decontamination, breaking of dormancy or increase in the length of seed sprout.^[25–34] Plasma treatment of seeds became one of the starting points in opening of a wide area of applications of plasmas in agriculture and related biotechnologies. Nowadays, this list is much wider including treatments of seeds, soil, usage of plasma activated water, etc.^[35–41]

In direct plasma treatments, i.e. where seeds are in direct contact with plasma or afterglow, the surface of seeds undergoes a variety of changes. During the plasma treatment, depending on the plasma conditions, the surface is activated so other functional groups can be attached (-COOH, -COH, -COO, -NH₂, -OH, -NO, etc.). Also, during the treatment seed surface is etched and, at the same time, decontaminated from various types of microbes. As a result the surface contact angle is reduced and seeds' surface changes from hydrophobic to hydrophilic.^[42,43] The main species responsible for this type of changes are neutrals and ions of nitrogen and oxygen, especially O(³P), O₂(¹Δ_g), O₃, NO, N, O(¹D) and O₂⁻ ion, which is signaling molecule in most of the cell processes. Lately, as an alternative to the direct plasma treatment of seeds and plants, application of water treated by plasma, the plasma activated water (PAW), gives similar results in the increase of germination percentage, decontamination of both seeds and plants and faster growth.^[44–46] The reason for these enhancement lies in the fact that in comparison to regular water PAW contains large amounts of chemically active species produced in plasma and at the plasma-liquid interface. These species are transferred from the interface volume to the liquid bulk and are able to trigger desired responses in biological samples. Some of the most important species appearing in the liquid bulk of PAW that are involved in triggering cell mechanisms are OH, O, NO, H, H₂O₂, NO₂⁻, O₂⁻, NO₃⁻, OH⁻.^[47–50] In this paper, we want to compare the effects of these two significantly different types of treatments on the seeds of model plant *P. tomentosa* Steud. To accomplish this we have used a low pressure radio-frequency (RF) plasma system for direct treatment of seeds and an atmospheric pressure plasma jet (APPJ)^[51] for treatment of distilled water in order to obtain PAW which is then used for

imbibition of the seeds. In addition to being a model plant *P. tomentosa* is a viable agricultural product often used in medical supplements and as addition to alcoholic drinks.

Seeds of *P. tomentosa* are positively photoblastic and their germination is phytochrome-controlled. The light requirement for maximum germination may vary from brief exposure to several hours of red light, depending on seed maturation conditions.^[52] A large number of RONS are continuously produced during seed and plant development, from embryogenesis to germination.^[53] However, cells have evolved protective mechanisms in order to control free radical-induced cellular damage.^[54]

Process of *P. tomentosa* seeds germination consists of three phases: imbibition, the phase of phytochrome activity and the phase of radicle protrusion and elongation. The optimum imbibition time is 3 d. Previous findings showed that a 5 min illumination with red light (660 nm) is sufficient for the phytochrome activation, the phase that lasts from 48 to 72 h. The processes following, including radicle protrusion, require several days after which germination is completed.^[52,55,56]

In the experiments that will be presented in this paper we have investigated the early phase of germination, preferentially immediately after the light treatment and up to 3 d after the phytochrome activation, through CAT enzyme protein content and activity. Catalase (CAT, EC 1.11.1.6) is a tetrameric protein found in all aerobic organisms that catalyzes the dismutation of H₂O₂ into water and oxygen.^[57] CAT represents one of the several cellular antioxidant defenses that play an important role in scavenging reactive oxygen species (ROS).^[58] It was shown that, particularly in oily seeds, CAT is very important in the early germination events because it removes H₂O₂ produced during β-oxidation of the fatty acids.^[59]

Increased generation of ROS seems to be a common feature of the early germination phase, which is the critical step of the process, since it involves activation of a regulatory system controlled by intrinsic (i.e., dormancy) and extrinsic (i.e., environmental conditions, such as temperature, oxygen, and water availability) factors.^[53]

Plasma treatment has been found to promote seedling growth, increase proline concentration as well as activities of superoxide dismutase (SOD) and peroxidase (POD) in wheat seedlings under drought stress.^[60] Similar observations have been made for oilseed rape seedlings, confirming that SOD and CAT activities were significantly increased after cold plasma treatment. Jiang et al.^[61] reported that cold plasma treatment increases activities of POD, phenylalanine ammonia lyase (PAL), and polyphenol oxidase (PPO) of tomato under disease stress.^[62] In spite of these studies of antioxidant enzymes activity in plasma treated seedlings and plants, evaluation of cold plasma effect on seeds during germination has not been investigated. Having in mind that plasma treatment of seed induces a significant increase in germination, it is of particular interest to study the effect of plasma on seeds.

Hydrogen peroxide is widely generated in plants and mediates various physiological and biochemical processes. As a signaling molecule, it can activate proteins/genes related to plant growth and development. Accumulation of hydrogen peroxide can reinforce cell walls through lignification. CAT activity is essential for the removal of the potentially toxic hydrogen peroxide produced under various stress conditions and then for the avoidance of oxidative-stress-related damage.^[63] CAT is also important in fine-tuning the cellular H_2O_2 and then in modulating the related signaling pathways.^[64,65]

In order to investigate the correlation between the plasma effects and CAT activity and protein content during the initial stages of germination process we performed direct treatment of *P. tomentos*a seeds in an asymmetrical capacitively coupled plasma (CCP) reactor under two different pressures and several treatment times. Apart from direct plasma treatment of seeds, an indirect treatment method was used where we treated distilled water by using APPJ in order to obtain PAW. After the treatment, PAW was used for imbibition of *P. tomentos*a seeds. In both cases, the CAT activity and protein content was evaluated during 4 d following the imbibition process, i.e., immediately after the phytochrome activation and in the 3 subsequent days.

2 | EXPERIMENTAL SECTION

2.1 | Low pressure plasma treatments

Low pressure treatments of seeds were performed in the cylindrically shaped capacitively coupled plasma (CCP) reactor with a powered electrode centrally positioned along the axis (see Figure 1). This asymmetrical system has ability to produce large volume of homogeneous plasma performing mild treatments of many seeds at the same time. Until now it was successfully used for different types of textile treatments^[66,67] and in treatments of seeds and commercial grains for disinfection and to increase the germination percentage.^[26,27,68] It was previously characterized in more detail and also the PIC model was used to estimate the main parameters of plasma treatments.

Main goal in construction of this RF plasma system was to achieve homogeneous plasma in large volume with the low energy of ions that bombard the grounded electrode that serves as sample holder. This was achieved by using large surface ratio between the powered and grounded electrode ($A_{pow}/A_{gnd} = 700$). The results obtained from the PIC simulation show us that the energy of ions impinging the grounded electrode and the samples are around 1–2 eV. The samples are positioned on the grounded electrode and due to their small size we can say that they are positioned in the plasma sheath. The estimation of the sheath thickness obtained from the PIC simulation is around 2 cm at the

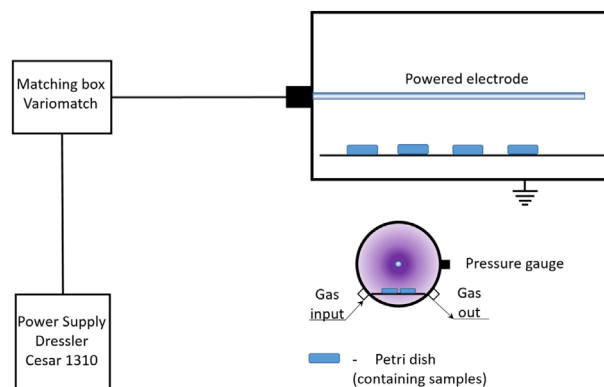

FIGURE 1 Schematics of the experimental set-up

grounded electrode. At the same time the electrical field at this electrode does not exceeds 75 V/cm. The averaged concentration of oxygen ions given by PIC analysis is $\sim 10^{15} \text{ m}^{-3}$.^[69,70] The concentration of neutral oxygen atoms obtained by using catalytic probe in the same chamber geometry, but larger in scale, is of the order of 10^{19} m^{-3} . It was shown that the concentration of ions coincides with the results obtained by PIC simulation ($\sim 10^{15} \text{ m}^{-3}$). Mass spectrometry measurement revealed that the main ions in the discharge are O^- , O_2^- , O_2^+ , and O^+ . But the most important is the presence of the atomic and molecular oxygen metastables, especially $O_2(^1\Delta_g)$. As with other species that concentration of excited and metastable increases with the increase of working pressure.^[71]

The length and diameter of the chamber are 46 and 37.5 cm, respectively. Chamber wall, which serves as the grounded electrode, is made of stainless steel while the powered electrode is made of aluminum. The powered electrode is axially placed, with length of 40 cm and diameter of 1.4 cm. The electrode is powered by RF signal at 13.56 MHz through automatically adjusting matching network. The power during the treatments was kept constant at 100 W given by RF power supply (Dressler Cesar 1310).

The platform for holding samples is positioned 13 cm below powered electrode. Since it is connected to the chamber wall it is also electrically grounded. A door mounted on one side of the cylindrical chamber provides an easy access and allows positioning of samples on the holder.

During all treatments flow of the gas was controlled by a flow controller connected to the gas inlet of the chamber while the exhaust line was connected to the mechanical pump. Here we need to emphasize that only mechanical pump was used. Therefore, the baseline pressure that could be reached was 20 mTorr which implies that certain amount of impurities (air, in particular) were present. Pressure in the chamber was measured by a capacitive gauge attached to one of the chamber ports.

Treatments were performed in oxygen at pressures of 200 and 600 mTorr which, with a constant pumping speed,

corresponded to gas flows of 80 and 435 sccm. For each pressure four different treatment times were engaged: 1, 5, 10, and 20 min. During the treatments four Petri dishes (6 cm in diameter), each containing 100 seeds, were positioned on the platform inside the chamber. After the end of the treatment, the seeds were immediately taken out of the chamber and transferred to other sterile Petri dishes. The imbibition of the treated seeds was performed by using 3 ml of distilled water.

2.2 | Atmospheric pressure plasma treatments – Plasma Activated Water

We have used a standard atmospheric pressure plasma jet (APPJ)^[51,72,73] for treatments of distilled water (see Figure 2). After the treatments, the obtained plasma activated water (PAW) was used for imbibing the *P. tomentosa* seeds. The design of the APPJ used in the experiments is simple and it consists of a glass tube with the electrode made of copper tape wrapped around the tube 5 mm from its end. The outer and inner diameters of the glass tube were 6 and 4 mm, respectively. The electrode was connected to a high voltage sinusoidal signal of 50 kHz that allows plasma to ignite immediately after the signal is turned on. The high voltage signal is obtained by home-made power supply system consisting of a function generator (PeakTech DDS Function Generator 4025), a home-made amplifier, and a high-voltage transformer.

To allow operation of plasma in glow regime,^[16,74] He gas was flown through the tube with the rate of four slm. For treatments of water, the jet was positioned vertically with a glass Petri dish underneath. At the bottom of the dish we placed copper tape that was connected to the ground through a 100 k Ω resistance. This electrical circuit permits monitoring of the discharge current going to the ground by measuring the voltage drop on the resistor. At the same time, high-voltage probe connected to the powered electrode measures voltage supplied to the

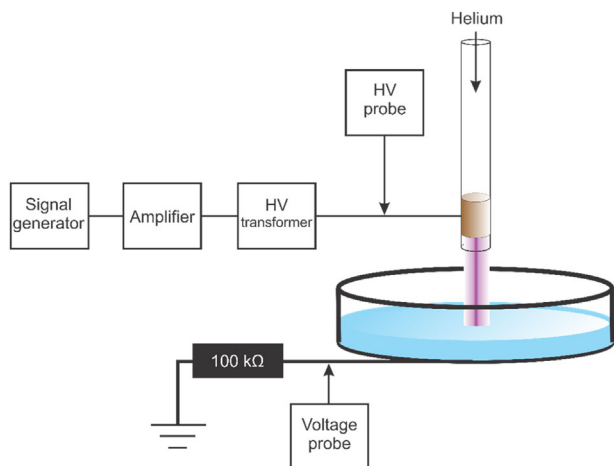

FIGURE 2 Experimental set-up for treatment of distilled water

plasma jet. To produce plasma activated water we placed 12 ml of distilled water into the Petri dish (6 cm in diameter). The distances between the end of the glass tube of the jet and the water surface used in treatments were 0.5 and 1 cm. For both distances the applied voltage was kept constant at 6 kV_{Peak-to-Peak} and measured current was 6 mA_{Peak-to-Peak} for 0.5 cm distance and 4 mA_{Peak-to-Peak} for the distance of 1 cm. The water volume after treatments was checked and found to be the same as the initial. Treatment times were 5, 10, and 20 min.

In order to characterize PAW we have measured pH and dissolved oxygen content immediately after the treatment. Dissolved oxygen content analysis measures the amount of gaseous oxygen (O₂) dissolved in an aqueous solution. For the pH measurements we have used Hanna Instruments HI1131B pH electrode with HI5522 controller and for the percentage of dissolved oxygen in water Hanna Instruments DO electrode HI764080 powered by HI2004 unit.

2.3 | Plant material and seed treatment

Seeds of the empress tree (*P. tomentosa* Steud.) were collected during 2015 in the Garden of the Institute for Biological Research “Siniša Stanković,” University of Belgrade, and stored at room temperature until use. Batches of 100 seeds (plasma pre-treated or not) or 200 seeds (PAW treated or not) were placed in Petri dishes (6 cm in diameter) and imbibed with 3 ml of distilled water or plasma treated water, respectively. Germination was performed at 25 ± 2 °C, in darkness. Seeds were induced to germinate with a 5 min red light pulse (660 nm, Philips TL 20/15 fluorescent tubes with 3 mm plastic Röhms & Haas filters, No. 501; fluence rate 3.54 μmol m⁻² s⁻¹) applied after 3 d of imbibition.^[52] Seed samples were taken subsequently during next 4 d, in 24 h intervals, weighted and stored at -70 °C until further analysis. A weak green safelight was used for manipulations in the dark. All experiments were repeated twice, with 3–5 replicates each. The schematics of the procedure for the sample collection is given in Figure 3.

2.4 | Protein extraction

P. tomentosa seeds (about 0.025 g FW) were grounded in liquid nitrogen with a mortar and pestle and homogenized in 1 ml of potassium phosphate buffer (100 mM, pH 7.5) containing 2 mM PMSF, 0.5 mM EDTA, 0.5% Triton X-100, and 2% (w/v) polyvinylpyrrolidone (PVPP). The homogenates were centrifuged at 14000×g for 20 min, at +4 °C. The supernatant was used for assays. Protein content in seed extracts was determined according to Bradford^[75] using bovine serum albumin as a standard.

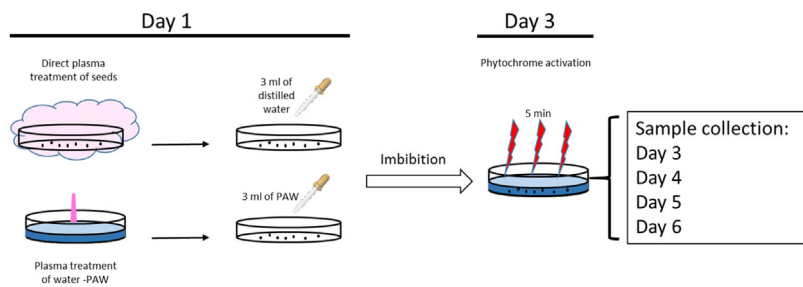

FIGURE 3 The experimental procedure for collecting the samples for enzyme analysis

2.5 | Native polyacrylamide gel electrophoresis and enzyme activity staining

Proteins were separated on the 10% non-denaturing polyacrylamide gel. Electrophoresis was performed at +4 °C for 2.5 h, at constant current of 120 V using Mini-Protein II system (Bio-Rad, Richmond, CA). Equal amounts of proteins (30 µg) were loaded on gels. Gels were stained for CAT activity according to Woodbury et al.^[76]

2.6 | SDS-PAGE and immunoblotting

Samples for sodium dodecyl sulfate polyacrylamide gel electrophoresis (SDS-PAGE) were dissolved in the equal volume of Laemmli buffer.^[77] Separation of proteins was performed at room temperature using Mini-Protein II system (Bio-Rad, Richmond, CA) for 50 min at 200 V. Equal amounts of proteins (15 µg) were loaded on 10% SDS polyacrylamide gels. For detecting molecular weight of separated proteins, colored molecular weight markers 10–260 kDa (Spectra™ Multicolor Broad Range Protein Ladder, Fermentas GmbH, Germany) were used. After separation, proteins were transferred electrophoretically (60 V for 1.5 h, at 4 °C) onto PVDF membranes (Bio-Rad, SAD) using Mini Trans-Blot Module (Bio-Rad, SAD). Membranes were blocked overnight at 4 °C in a solution of 10% (w/v) non-fat dry milk (NFDM; Nestle, USA) and probed with anti-catalase antibody (1:1000, AS09501; Agrisera Antibodies, Sweden), and goat HRP conjugated anti-rabbit IgG secondary antibody (1:20000, Ao545, Sigma Aldrich, St. Louis, USA). Secondary antibodies were visualized using an enhanced chemiluminescence detection system (ECL) and densitometrically quantified using ImageJ 1.32j software (W. Rasband, National Institute of Health, USA).

2.7 | Statistical analysis

Densitometry was performed on scanned gel and immunoblot images using the ImageJ gel analysis tool.^[78] Statistical analysis was performed using Stagraphics software, version 4.2 (StatPoint, Inc. 1982–2006, USA). Differences among different treatments were tested using standard analysis of variance

(ANOVA). The means were separated using Fisher's Least Significant Difference (LSD) post hoc test for $p \leq 0.05$. Treatments denoted by the same letter are not significantly different ($p \leq 0.05$).

3 | RESULTS AND DISCUSSION

3.1 | Low pressure plasma treatments

It was previously shown that asymmetrical CCP system described above can be successfully used in treatments of *P. tomentosa* seeds in order to increase percentage of germination. However, the effect of plasma on germination is affected by plasma parameters like electric field, power, time, pressure, and type of gas used in treatments.

It is well documented that electric field can positively influence germination.^[79,80] On the other hand, detrimental effect can appear if seeds are exposed to electric field for a very long time or if the field is very strong.^[79] In our case electric field (75 V cm^{-1}) influencing the samples is quite low comparing to the electric fields (up to several kV cm^{-1}) used in literature. We believe that influence of electric field is not significant and main effect is obtained through bombardment of the seed surface by reactive chemical species created in the plasma and accelerated by the electric field in the sheath.

Regarding the plasma power, it was shown that higher powers can induce damage to the seeds due to increased thermal effects and destruction of seed wall by particle bombardment. Therefore, for our chamber it was found that optimal treatment times are up to 10 min for power of 100 W.^[26,27,66] Concerning the pressure, its changes affect densities and energies of particles present in plasma (the most important are reactive species such are O^- , O_2^- , O_2^+ , O^+ , and $\text{O}_2(^1\Delta_g)$). At lower pressures, densities of particles produced in plasma are lower, but they have higher energies due to fewer number of collisions, i.e., longer mean free paths.^[4] Energies of ions are directly influenced by the pressure through the balance of energy gained from the field and dissipated in collisions. Fast neutral particles can be affected indirectly as those may be created by the charge exchange collisions with ions.^[81]

In our case, we performed treatment at two pressures which are not far apart: 200 and 600 mTorr. Thus, the main difference between two pressures would be in higher particle densities (neutrals, radicals, and ions) that reach surface of treated seeds at 600 mTorr in comparison to the case of 200 mTorr. Taking into account all this, a set of plasma parameters close to the optimal for germination has been chosen in order to investigate the response of the CAT enzyme to the plasma treatments.

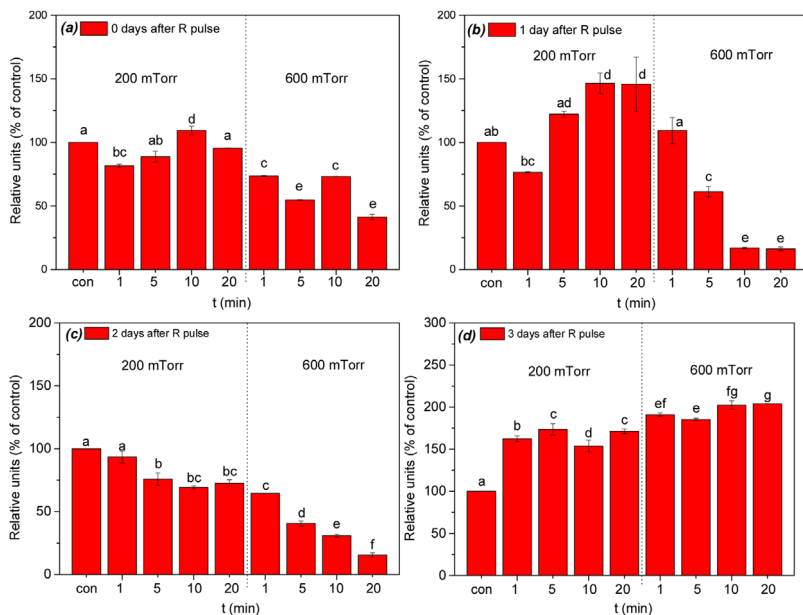

FIGURE 4 Catalase activity in plasma treated *P. tomentosa* seeds measured immediately (a), 1 d (b), 2 d (c), or 3 d after R light pulse (d). Results for different treatment times (t) and two pressures are shown. The band volume was recorded by using densitometric analysis. Data were normalized using control signal. Values are means obtained from three independent experiments shown with standard error. Treatments denoted by the same letter are not significantly different ($p \leq 0.05$) according to the Fisher's LSD test

As for the effect of the pressure on the seeds and their germination, the selected seeds do not have a hydrophobic protective seed coat so oxidization of the protective layer to allow water to penetrate the seed is not an issue. It has been postulated^[26,27] that a deposition of different active molecules and radicals may promote germination and growth of these seeds mainly through their signaling functions in the cell. Thus the explanation of the effect must be sought in plasma chemistry leading to production of active species. Understanding, control, and optimization of the effects of plasmas depends on being able to connect the plasma chemical processes to the processes inside the cells of the seed. The effect of plasma should be small enough to promote the germination and not too large to have detrimental effect on the living cells.

We have measured both CAT protein content and CAT enzyme activity at the beginning of the germination process (immediately after activation of phytochrome) and in 3 subsequent days. The activity of CAT for samples treated for different times is shown in Figure 4. Relative intensity for each experimental band was calculated by normalizing the experimental absolute intensity to the corresponding control absolute intensity. One should bear in mind that the control group follows the entire process as other seeds with the exception of plasma treatment (see Figure 3). In other words, control groups have passed imbibition (3 d) then they were initiated by the R pulse and then subsequently taken for analysis in 4 subsequent days. Standard behavior of CAT enzyme activity in control samples of

P. tomentosa is observed and it increases after R light pulse. CAT is only one of the relevant enzymes that is responsible in early stages of germination and later on peroxidase becomes even more important. Both of these enzymes together with the related radicals play their part in a complex mechanism of germination that is being triggered by plasma. Thus, one cannot easily correlate activity of one enzyme to the efficiency of germination. While effects of plasma are similar and in the same direction as those reported earlier^[26,27] results will strongly depend on the season, duration of storage, and other parameters. Thus we have to find optimal conditions for each batch. In addition we have improved performance of our plasma source in the meantime.

When comparing the effects of pressures on the enzyme activity measured immediately after the activation of the phytochrome (day 0), the samples treated in plasma at 600 mTorr of oxygen exhibit a higher reduction in CAT activity if compared to 200 mTorr treatments (see Figure 4(a)). On the contrary, for the treatment at 200 mTorr changes in the activity are small, seeds treated for 1 min show slightly lower activity, while the others show either similar (5 and 20 min) or slightly higher (10 min) CAT activity. Similar trends can be observed in the samples collected on day 1 (see Figure 4(b)) with a much larger increase of the activity at 200 mTorr. The treatments with higher pressure (600 mTorr) and longer treatment times (10 and 20 min) induce four times lower CAT activity compared to the untreated sample. At the same time for pressure of 200 mTorr we can see increase in the CAT activity as the treatment time increases. Two days after the R pulse the enzyme activity declines more or less linearly with increment of pressure and treatment time (see Figure 4(c)). Thus, CAT activity in seeds after 20 min treatment at 600 mTorr was nearly four times lower in comparison with control samples. However, 3 d after the R pulse the activity of CAT increased for both treatments, exhibiting 1.5–2 fold higher values in comparison with CAT activity measured in control samples (Figure 4(d)). *P. tomentosa* seeds are positively photoblastic, meaning that their germination is stimulated by light. After the imbibition (rapid initial water uptake) seeds were induced to germinate by red light pulse, and entered the next-plateau phase.^[82] Plateau phase involves the reactivation of metabolism, including the resumption of cellular respiration, the biogenesis of mitochondria, DNA repair, the translation and/or degradation of stored mRNAs, the transcription and translation of new mRNAs, and the activation of antioxidant enzymes at the appropriate time.^[83,84,85] Therefore, sequential expression of antioxidant enzymes has been considered to

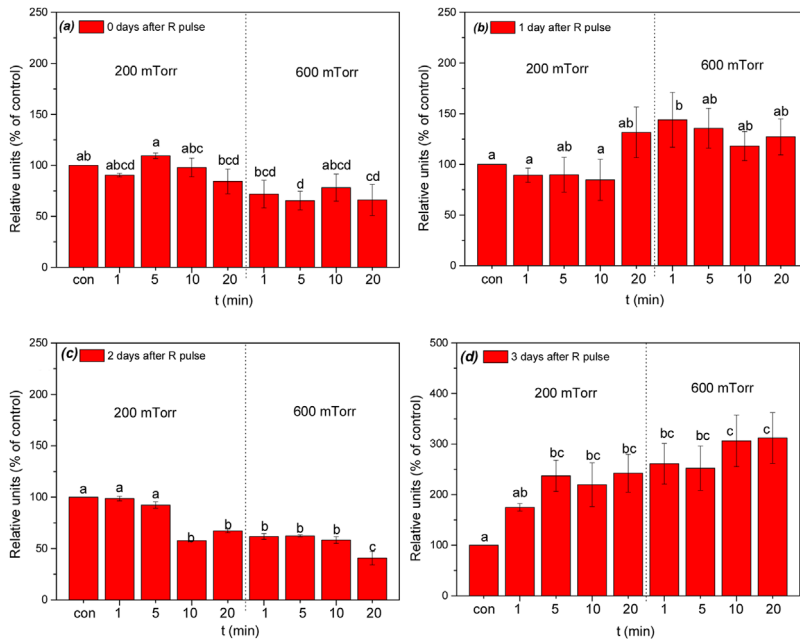

FIGURE 5 Immunoblot analysis of catalase in *P. tomentosa* seeds, measured immediately (a), 1 d (b), 2 d (c), or 3 d after R light pulse (d). Results for different treatment times (t) and two pressures are shown. The band volume was recorded by using densitometric analysis. Data were normalized using control signal. Values are means obtained from three independent experiments shown with standard error. Treatments denoted by the same letter are not significantly different ($p \leq 0.05$) according to the Fisher's LSD test

be of particular importance for the completion of germination.^[86,87] It is possible that a renewal of antioxidant system may be initiated with the repair of cell membranes and organelle development, which are required for complete germination and growth demands by the seedlings.^[88] Increased CAT activity could be an indication of the cellular evaluated ROS, since the amount of CAT present in aerobic cells is directly proportional to the oxidative state of the cells.^[89] Measurement of CAT activity may be a parameter to determine seed viability and germination as observed by Baily et al.^[90]

With few exceptions, radicle extension through the structures surrounding the embryo is the event that terminates germination and marks the commencement of the seedling growth.^[91] The time for this event to be completed varies from several hours to many weeks, depending on the plant species and the germination conditions. The present study shows a significant increase in the enzyme activity 3 d after R pulse (see Figure 4(d)), which can be associated with metabolic switch occurring in seeds between germination and subsequent post-germination phase. Apart from CAT, it was shown previously that another antioxidant enzyme peroxidase (POD) also has very important role in germination. In *P. tomentosa* seeds activity of POD is very low before the process of radicle protrusion begins, i.e., the activity is increased during later phases of germination. On the other hand, in germinated seeds and seedlings, POD activity

increases significantly.^[92] Final result of seed germination process (measured as percent of germinated seeds) will be reflection of overall metabolic activity in seeds and young seedlings, including antioxidant enzymes activity (e.g., CAT, but also the activity of other enzymes).

Immunoblot analysis showed that only one isoform of 50 kDa is detected in all the samples and in Figure 5 we present the results of CAT protein content obtained for the same set of parameters as CAT activity. Germination process immediately and 1 d after the R light pulse resulted in an increase in CAT protein content, but with slight difference in comparison to the control seeds (Figure 5(a, b)).

Significant reduction in CAT content was observed 2 d after the phytochrome activation (see Figure 5(c)). Here we can observe a reduction in CAT protein content for longer treatment times at 200 mTorr and for all treatment times at 600 mTorr. Similar behavior was observed in the CAT activity (Figure 1(c)). It should be noted that enzyme content was by far the highest in treated seeds 3 d after the activation of phytochrome (about 2.5 fold greater than control samples) and remained more or less constant regardless of experimental

conditions used in this study. Enhanced CAT protein content is in accordance with the increment in enzyme activity in germinating seeds showed in Figure 4(d). It must be remembered that immunoblot analysis gives indications about the synthesis of CAT subunits and does not necessarily reflect the enzyme activity.^[93] This may explain why the slight apparent decrease or increase in protein content (Figure 5) was not correlated with the changes of CAT activity in the same batch of *P. tomentosa* seeds (Figure 4).

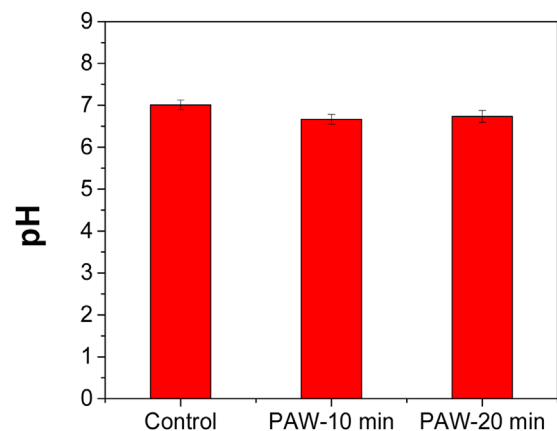

FIGURE 6 pH values of plasma treated water for two different treatment times. Distance from the edge of the glass tube of the plasma jet and water surface was 1 cm

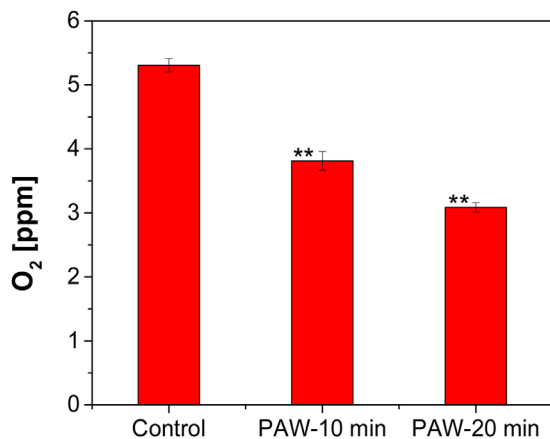

FIGURE 7 Dissolved oxygen content in treated water in the control sample and after the treatments. Distance from the edge of the glass tube of the plasma jet and water surface was 1 cm

3.2 | Atmospheric pressure plasma treatment of distilled water - PAW

Unlike the case of low pressure treatments where seeds were in direct contact with plasma, when it comes to APP treatments the seeds are only indirectly influenced by plasma through the imbibition with plasma activated water. CAT activity and protein content are more affected when plasma is

further away from the liquid for all durations. While this may be counter intuitive it could be the result of the liquid interrupting the plasma at closer proximities or it may result from the greater obstruction to the gas flow including more likely turbulence for smaller proximity. During the water treatment reactive species produced in the plasma are transported to the gas-liquid interface from where they can penetrate and/or induce chemical reactions and creation of new species in the bulk liquid.^[47,94] Some of these species, like H₂O₂, O₂⁻, NO₂⁻, NO₃⁻, have direct influence on processes in biological systems so changes in their concentration should affect enzyme activity. Before using PAW for imbibition of seeds, we have measured pH of treated water and amount of dissolved oxygen (DO) after plasma treatments. Measurements of pH were performed as described in experimental section and the results are presented in Figure 6.

In Figure 6 we can see that plasma does not change significantly the pH value of treated water. In other words, we kept plasma treatment within the limits of only small variations of pH value in order to avoid detrimental effect due to a significantly changed pH factor. Its value is slightly decreased, from pH_{Ctrl} = 7 to pH_{treat} = 6.7, after the treatments (regardless of treatment time). Gregory D. et al. showed that process of germination and seedling growth of *P. tomentosa* seeds is influenced if the pH values of the environment are below pH = 5.^[95] If the pH values are in the range 6–7, the germination process and development of the seedling is not influenced. Similarly, the CAT activity in plants is pH-dependent.^[96] Arabaci and Usluoglu showed that the CAT activity is significantly influenced if the pH value drops below 4.^[97] Therefore, taking into account measured pH, our PAW used for imbibition of *P. tomentosa* seeds should have negligible influence on the enzyme activity and germination of seeds due to the change in pH.

Another parameter that was measured was oxygen content in the water before and after the treatment. The results are shown in Figure 7. We can see that plasma treatment reduces the oxygen content in water. The reduction of the oxygen content can be assigned to the presence of the helium flow.^[98] The presence of He flow above the water surface reduces the partial pressure of O₂ and therefore reducing the solubility of oxygen in the water. The He flow used in the experiment is sufficient to create sparging effect and cause decrease of oxygen content.^[99] With an increase of the treatment times at distance of 1 cm oxygen content is reduced by 40%. Similar result is observed at

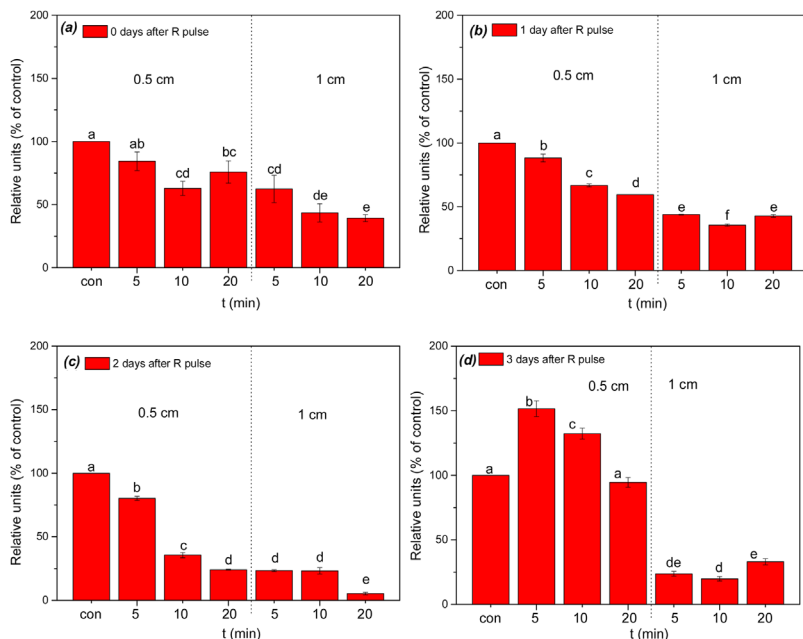

FIGURE 8 Catalase activity of *P. tomentosa* seeds germinated in plasma treated water, measured immediately (a), 1 d (b), 2 d (c), or 3 d after R light pulse (d). Results for different treatment times (t) to obtain PAW and two distances are shown. The band volume was recorded by using densitometric analysis. Data were normalized using control signal. Values are means obtained from three independent experiments shown with standard error. The values with the same letter indicate statistically homogenous groups ($p \leq 0.05$), as per Fisher's LSD test

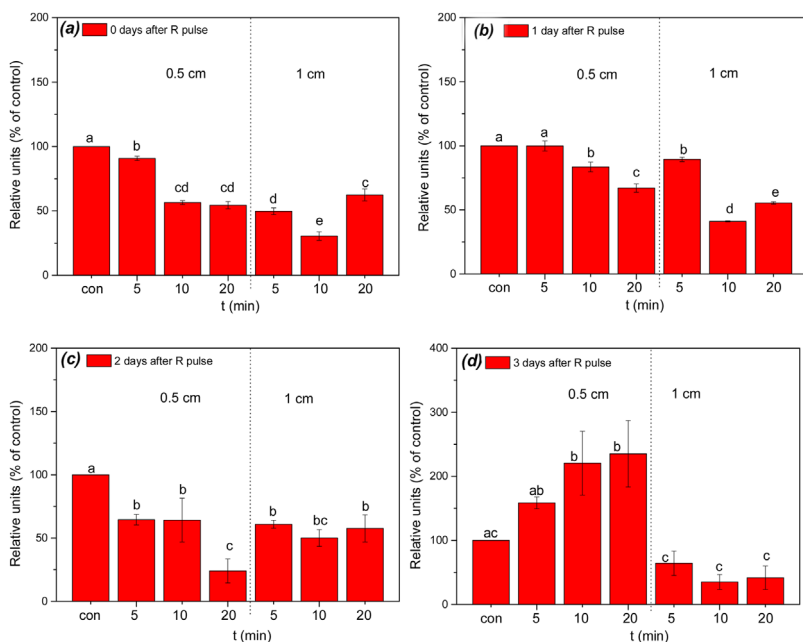

FIGURE 9 Immunoblot analysis of catalase in *P. tomentosa* seeds germinated in plasma treated water, measured immediately (a), 1 d (b), 2 d (c), or 3 d after R light pulse (d). Results for different treatment times (t) to obtain PAW and two distances are shown. The band volume was recorded by using densitometric analysis. Data were normalized using control signal. Values are means obtained from three independent experiments shown with standard error. Treatments denoted by the same letter are not significantly different ($p \leq 0.05$) according to the Fisher's LSD test

both distances. One has to bear in mind that oxygen content cannot be directly correlated with CAT activity due to the complexity of mechanisms involved.

Nevertheless, the seed germination is particularly sensitive to oxygen deficiency. The oxygen requirement for seeds typically varies depending on the species and their dormancy status.^[100] During early phase of imbibition, seeds consume oxygen at slower rates, but at a much higher rate during radicle protrusion and hypocotyl growth. For example, Rajashekar and Baek show that oxygen limitation during imbibition can produce adverse effects which may last during early seedling growth and development. On the other hand, adding of the hydrogen peroxide reversed the effect of hypoxia resulting in normal hypocotyl elongation and stem growth.^[101]

CAT enzyme activity obtained after the imbibition with PAW is shown in Figure 8. The samples were collected and the CAT activity is measured in the same manner as in the case of low pressure plasma treatments. As in the low-pressure case, the data were normalized to signal of the control group of the corresponding day. We can see that CAT activity in samples that were imbibed with PAW is lower than in the untreated samples immediately after the phytochrome activation and in 2 subsequent days (see Figure 8(a–c)). Also, the activity does not change significantly between day 0 and day 1 (see Figure 8(a, b)). In both cases it is decreased

maximally 2.5–3 times if compared with control samples. At day 2 we have even more reduction in CAT activity, going up to 10 times lower than untreated samples (see Figure 8(c)). In all cases, the reduction in the activity is higher for PAW treated with 1 cm distance between the plasma jet tube and water surface than for the case of 0.5 cm distance. The decrease in CAT activity within 3 d after R light pulse (Figure 8(d)) can be to some extent correlated to the decreased level of dissolved oxygen.

Significant increase in CAT activity occurred 3 d after the R light pulse at 0.5 cm treatment (Figure 8(d)), and it appears that this increment corresponds to the initial phase of post germination process, designated as phase of radicle protrusion and elongation, as already mentioned above.

Most likely CAT reserves are broken down during early stages of germination and de novo synthesis is occurring along with the radicle protrusion. It should be noted that ROS produced in PAW, especially hydrogen peroxide, could mitigate the adverse effects of hypoxia, both during imbibition and germination, as it can generate free oxygen and water by CAT and other catalysts including many transition metal ions present in the seeds.^[102] When density of radicals increases it is likely that it would stimulate a greater production of CAT. If that production is insufficient to keep up with radicals, then depletion may occur. In addition, several radicals and other active species may participate in the kinetics of a particular enzyme. Active species produced in PAW, such as nitrate (NO_3^-) and nitrite (NO_2^-) ions most likely deposit on the seed surface, having an influence on seed germination as well as on the CAT activity. The same is true for hydrogen peroxide (H_2O_2). Although it could be expected that H_2O_2 concentration increases with treatment time, which would result in higher CAT activity, Figure 8 shows the opposite results (lower CAT values for longer treatment time of PAW), particularly for 0.5 cm treatment. Most likely higher content of ROS produced in the case of 0.5 cm treatment contributes to the higher levels of active species that could impair the enzyme activity. Precise regulation of H_2O_2 accumulation by cell antioxidant machinery is crucial to achieve a balance between oxidative signaling that promotes germination and oxidative damage that prevents or delays germination. According to “oxidative window” hypothesis proposed by Bailly et al.,^[103] both lower and higher levels of ROS impair seed germination, and it is only possible within a critical range of concentrations.

One subunit of 50 kDa was present in *P. tomentosa* seeds in all treatments (Figure 9). The intensity of the band

corresponding to the CAT subunit appeared to decrease significantly for both treatment distances in comparison to the control sample, up to 3rd day after the R light pulse. A sharp decline in CAT protein content (1.5–2 fold) was noticed immediately after the R light pulse, for longer exposure treatments at 0.5 cm distance (10 and 20 min) and for all treatments at 1 cm distance between the jet and water surface, respectively (Figure 9(a)). CAT content in PAW treated seeds showed similar pattern on the 1st and 2nd day after the phytochrome activation (Figure 9(b, c)). Subsequent germination process (3 d after R pulse) resulted in an increase in CAT protein content in seeds after the 0.5 cm distance PAW treatment, but after the 1 cm PAW treatment it showed no significant difference compared to control seeds (Figure 9(d)).

One should bear in mind that different levels of enzymatic activity are not exclusively dependent on enzyme synthesis, but on various other factors as well. Thus, in future studies it would be advisable to take into account the differences between the effect of plasma treatment on germination and subsequent post-germination process of *P. tomentosa* seeds, suggesting that CAT activity at these stages may be subject to post-translational regulation.

4 | CONCLUSION

In this paper we have presented results of CAT enzyme activity and protein content obtained during the second phase of germination of *P. tomentosa* seeds (phase of phytochrome activity). Two significantly different types of plasma treatments were used. In the first type, the seeds were in direct contact with plasma and, in the second, atmospheric pressure plasma was used for obtaining PAW which is then applied to the seeds. In the former case, for direct plasma treatments, we have used low pressure RF discharge that was previously shown to be a good solution for increasing germination percentage of *P. tomentosa* seeds.^[26,27] In the latter case, an APPJ was used in order to obtain PAW and immediately after the plasma treatment of water pH and dissolved oxygen content were measured. In our case the pH does not change significantly and stays in the range 6.5–7. Therefore, the processes related to germination and protrusion of radicle are not influenced by change in pH. On the other hand, the percentage of dissolved oxygen in the PAW is decreased to up to 40% compared to untreated water. This can influence the germination process in negative way by reducing the germination percentage, radicle protrusion, and slow early seedling growth and development. However, PAW contains H₂O₂ produced during plasma treatments which could substitute for O₂ deficiency and activate CAT genes for synthesis of new proteins.

We have observed standard behavior of CAT enzyme activity in control samples of *P. tomentosa* seeds. In these

samples the CAT enzyme activity increases in the first 3 d after R light pulse. However, both plasma treatments used in this study, low-pressure plasma seed treatment and PAW, cause decrease in CAT activity/protein content in seeds compared to the control samples in time period up to 2 d after R light pulse. For low-pressure direct treatments decayed levels of CAT activity and protein content are correlated to the treatment times and pressures with the biggest change for 600 mTorr and longest treatment time. In the case of indirect PAW treatment we observed similar behavior at the longest distance and for the longest treatment time of PAW.

Differences in CAT activity/content noticed 3 d after the inductive light pulse strongly suggest that approximately 48 h after the R pulse *P. tomentosa* seeds enter the 3rd phase of germination process—phase of radicle protrusion and elongation, i.e., germination *sensu stricto* is terminated and post germination processes take place.^[52] Moreover, discrete differences on the level of CAT content could be distinguished between the treatments used in this study.

ACKNOWLEDGMENT

This research has been supported by the Ministry of Education, Science, and Technological Development, Republic of Serbia, under projects III41011 and ON171037.

REFERENCES

- [1] P. Favia, G. Cicala, A. Milella, F. Palumbo, P. Rossini, R. d'Agostino, *Surf. Coat. Tech.* **2003**, 169, 609.
- [2] D. Mihailovic, Z. Saponjic, R. Molina, N. Puac, P. Jovancic, J. Nedeljkovic, M. Radetic, *ACS Appl. Mater. Interfaces.* **2010**, 2, 1700.
- [3] S. Vizireanu, S. D. Stoica, C. Luculescu, L. C. Nistor, B. Mitu, G. Dinescu, *Plasma Sources Sci. Technol.* **2010**, 19, 034016.
- [4] T. Makabe, Z. L. Petrovic, *Plasma Electronics: Applications in Microelectronic Device Fabrication*. CRC Press, Boca Raton, Florida, USA **2014**.
- [5] J. Vasiljević, M. Gorjanc, B. Tomšič, B. Orel, I. Jerman, M. Mozetič, A. Vesel, B. Simončič, *Cellulose* **2013**, 20, 277.
- [6] D. Kontziampasis, G. Boulousis, A. Smyrnakis, K. Ellinas, A. Tserepi, E. Gogolides, *Microel. Eng.* **2014**, 121, 33.
- [7] D. Dobrynin, G. Fridman, G. Friedman, A. Fridman, *New J. Phys.* **2009**, 11, 115020.
- [8] M. Gherardi, E. Turrini, R. Laurita, E. De Gianni, L. Ferruzzi, A. Liguori, A. Stancampiano, V. Colombo, C. Fimognari, *Plasma Process. Polym.* **2015**, 12, 1354.
- [9] E. Sardella, R. Gristina, G. S. Senesi, R. d'Agostino, P. Favia, *Plasma Processes Polym.* **2004**, 1, 63.
- [10] M. Vandamme, E. Robert, S. Lerondel, V. Sarron, D. Ries, S. Dozias, J. Sobilo, D. Gosset, C. Kieda, B. Legrain, J. M. Pouvesle, *Int. J. Cancer* **2012**, 130, 2185.
- [11] R. Matthes, C. Bender, R. Schlüter, I. Koban, R. Bussiahn, S. Reuter, J. Lademann, K. D. Weltmann, A. Kramer, *PLoS ONE* **2013**, 8, 70462.

- [12] Z. Machala, K. Hensel, Y. Akishev, *Plasma for Bio-Decontamination, BT Medicine and Food Security*. Springer Science & Business Media, Demanovska Dolina, Slovakia **2011**.
- [13] S. Lazović, N. Puač, M. Miletić, D. Pavlica, M. Jovanović, D. Bugarški, S. Mojsilović, D. Maletić, G. Malović, P. Milenković, Z. Petrović, *New J. Phys.* **2010**, *12*, 083037.
- [14] H. Tanaka, M. Mizuno, F. Kikkawa, M. Hori, *Plasma Med.* **2016**, *6*, 101.
- [15] S. Große-Kreul, S. Hübner, S. Schneider, D. Ellerweg, A. Von Keudell, S. Matejčík, J. Benedikt, *PSST* **2015**, *24*, 044008.
- [16] M. Gherardi, N. Puač, D. Marić, A. Stancampiano, G. Malović, V. Colombo, Z. L. Petrović, *Plasma Sources Sci. Technol.* **2015**, *24*, 064004.
- [17] A. Bogaerts, Z. Donko, K. Kutasi, G. Bano, N. Pinhao, M. Pinheiro, *Spectrochim. Acta B.* **2000**, *55*, 1465.
- [18] K. Kutasi, B. Saoudi, C. D. Pintassilgo, J. Loureiro, M. Moisan, *Plasma Process. Polym.* **2008**, *5*, 840.
- [19] M. J. Kushner, *J. Phys. D* **2005**, *38*, 1633.
- [20] M. S. Benilov, G. V. Naidis, *IEEE Trans. Plasma Sci.* **2003**, *4*, 488.
- [21] N. Škoro, N. Puač, S. Lazović, U. Cvelbar, G. Kokkoris, E. Gogolides, *J. Phys. D* **2013**, *46*, 475206.
- [22] Z. L. Petrović, S. Dujko, D. Marić, G. Malović, Ž. Nikitović, O. Šašić, J. Jovanović, V. Stojanović, M. Radmilovic-Radenovic, *J. Phys. D* **2009**, *42*, 194002.
- [23] R. D. White, R. E. Robson, S. Dujko, P. Nicoletopoulos, B. Li, *J. Phys. D* **2009**, *42*, 194001.
- [24] M. Savic, M. Radmilovic-Radjenovic, M. Suvakov, S. Marjanovic, D. Maric, Z. L. Petrovic, *IEEE Trans. Plasma Sci.* **2011**, *39*, 2556.
- [25] B. Šerá, V. Straňák, M. Šerý, M. Tichý, P. Špatenka, *Plasma Sci. Technol.* **2008**, *10*, 506.
- [26] S. Živković, N. Puač, Z. Giba, D. Grubišić, Z. Lj. Petrović, *Seed Sci. Technol.* **2004**, *32*, 693.
- [27] N. Puač, Z. Lj. Petrović, S. Živković, Z. Giba, D. Grubišić, A. R. Đorđević, *Plasma Processes and Polymers*, Weinheim, Germany **2005**, Ch. 15.
- [28] E. Bormashenko, R. Grynyov, Y. Bormashenko, E. Drori, *Sci. Rep.* **2012**, *2*, 3.
- [29] L. K. Randeniya, G. J. J. B. de Groot, *Plasma Process. Polym.* **2015**, *12*, 608.
- [30] B. Šerá, P. Špatenka, M. Šerý, N. Vrchotová, I. Hrušková, *IEEE Trans. Plasma Sci.* **2010**, *38*, 2963.
- [31] Z. Zhou, Y. Huang, S. Yang, W. Chen, *Agricultural Sciences* **2011**, *2*, 23.
- [32] B. Peethambaran, J. Han, K. Kermalli, J. Jiaying, G. Fridman, R. Balsamo, A. Fridman, V. Miller, *Plasma Medicine* **2015**, *5*, 87.
- [33] L. Sivachandiran, A. Khacef, *RSC Adv.* **2016**, *7*, 1822.
- [34] S. Ikawa, A. Tani, Y. Nakashima, K. Kitano, *J. Phys. D.* **2016**, *49*, 425401.
- [35] M. Hijosa-Valsero, R. Molina, H. Schikora, M. Müller, J. M. Bayona, *J. Hazard. Mater.* **2013**, *262*, 664.
- [36] V. I. Parvulescu, M. Magureanu, P. Lukes, *Plasma Chemistry and Catalysis in Gases and Liquids*. John Wiley & Sons, Weinheim, Germany **2012**.
- [37] N. Hayashi, A. Nakahigashi, M. Goto, S. Kitazaki, K. Koga, M. Shiratani, *Jpn. J. Appl. Phys.* **2011**, *50*, 08JF04.
- [38] G. Kamgang-Youbi, J. M. Herry, T. Meylheuc, J. L. Brisset, M. N. Bellon-Fontaine, A. Doubla, M. Naitali, *Lett. Appl. Microbiol.* **2009**, *48*, 13.
- [39] M. J. Traylor, M. J. Pavlovich, S. Karim, P. Hait, Y. Sakiyama, D. S. Clark, D. B. Graves, *J. Phys. D.* **2011**, *44*, 472001.
- [40] L. Sivachandiran, A. Khacef, *RSC Adv.* **2017**, *7*, 1822.
- [41] H. D. Stryczewska, K. Ebihara, M. Takayama, Y. Gyoutoku, M. Tachibana, *Plasma Process. Polym.* **2005**, *2*, 238.
- [42] L. Ling, J. Jiafeng, L. Jiangang, S. Minchong, H. Xin, S. Hanliang, D. Yuanhua, *Sci. Rep.* **2014**, *4*, 1.
- [43] L. K. Randeniya, G. J. J. N. de Groot, *Plasma Process. Polym.* **2015**, *12*, 608.
- [44] R. Ma, G. Wang, Y. Tian, K. Wang, J. Zhang, J. Fang, *J. Hazard. Mater.* **2015**, *300*, 643.
- [45] A. Bertaccini, A. Canel, V. Colombo, N. Contaldo, M. Gherardi, L. Laurita, A. Stancampiano, Y. Zambon, Presented at 6th ICPM, Bratislava, Slovakia, September, **2016**.
- [46] A. Bertaccini, E. Biondi, V. Colombo, M. Gherardi, L. Laurita, C. Lucchese, S. Perez, A. Stancampiano, Presented at 6th ICPM, Bratislava, Slovakia, September, **2016**.
- [47] P. J. Bruggeman, M. J. Kushner, B. R. Locke, J. G. E. Gardeniers, W. G. Graham, D. B. Graves, R. C. H. M. Hofman-Caris, D. Maric, J. P. Reid, E. Ceriani, D. Fernandez, Rivas, J. E. Foster, S. C. Garrick, Y. Gorbanev, S. Hamaguchi, F. Iza, H. Jablonowski, E. Klimova, J. Kolb, F. Krcma, P. Lukes, Z. Machala, I. Marinov, D. Mariotti, S. Mededovic, Thagard, D. Minakata, E. C. Neyts, J. Pawlat, Z. L. Petrovic, R. Pflieger, S. Reuter, D. C. Schram, S. Schröter, M. Shiraiwa, B. Tarabová, P. A. Tsai, J. R. R. Verlet, T. von Woedtke, K. R. Wilson, K. Yasui and, G. Zvereva, *Plasma Sources Sci. Technol.* **2016**, *25*, 53002.
- [48] M. M. Hefny, C. Pattyn, P. Lukes and, J. Benedikt, *J. Phys. D. Appl. Phys.* **2016**, *49*, 404002.
- [49] S. Samukawa, M. Hori, S. Rauf, K. Tachibana, P. Bruggeman, G. Kroesen, J. C. Whitehead, A. B. Murphy, A. F. Gutsol, S. Starikovskaia, U. Kortshagen, J. P. Boeuf, T. J. Sommerer, M. J. Kushner, U. Czarnetzki and, N. Mason, *J. Phys. D. Appl. Phys.* **2012**, *45*, 253001.
- [50] I. Adamovich, S. D. Baalrud, A. Bogaerts, P. J. Bruggeman, M. Cappelli, V. Colombo, U. Czarnetzki, U. Ebert, J. G. Eden, P. Favia, D. B. Graves, S. Hamaguchi, G. Hieftje, M. Hori, I. D. Kaganovich, U. Kortshagen, M. J. Kushner, N. J. Mason, S. Mazouffre, S. M. Thagard, H. R. Metelmann, A. Mizuno, E. Moreau, A. B. Murphy, B. A. Niemira, G. S. Oehrlein, Z. L. Petrovic, L. C. Pitchford, Y. K. Pu, S. Rauf, O. Sakai, S. Samukawa, S. Starikovskaia, J. Tennyson, K. Terashima, M. M. Turner, M. C. M. v. d. Sanden, A. Vardelle, *J. Physics D: Appl. Phys.* **2017**, *50*, 323001.
- [51] N. Puač, D. Maletić, S. Lazović, G. Malović, A. Đorđević, Z. L. Petrović, *Appl. Phys. Lett.* **2012**, *101*, 024103.
- [52] D. Grubišić, M. Nešković, R. Konjević, *Plant Sci.* **1985**, *39*, 13.
- [53] C. Bailly, H. El-Maarouf-Bouteau, F. Corbineau, *C. R. Biol.* **2008**, *331*, 806.
- [54] L. Rajjou, I. Debeaujon, *C. R. Biol.* **2008**, *331*, 796.
- [55] D. Grubišić, R. Konjević, *Planta* **1990**, *181*, 239.
- [56] D. Grubišić, Z. Giba, and, R. Konjević, *Photochem. Photobiol.* **1992**, *56*, 629.
- [57] J. G. Scandalios, L. Guan, A. N. Polidoros, *Cold Spring Harbor Monograph Series* **1997**, *34*, 343.
- [58] W. F. Beyer, Jr, I. Fridovich, *Oxygen Radicals in Biology and Medicine*, Springer, Boston, MA, USA **1988**, Ch. 49, p. 651.
- [59] J. D. Bewley, M. Black, *Seeds*, Springer, Boston, MA, USA **1994**, Ch. 1.
- [60] HU Ming-jing, *J. Shanxi Agricultural Sci.* **2010**, *11*, 9.
- [61] L. Ling, L. Jiangang, S. Minchong, Z. Chunlei, D. Yuanhua, *Sci. Rep.* **2015**, *5*, 13033.

- [62] J. Jiang, Y. Lu, J. Li, L. Li, X. He, H. Shao, Y. Dong, *PLoS ONE* **2014**, *9*, e97753.
- [63] H. Willekens, D. Inzé, M. Van Montagu, W. Van Camp, *Mol. Breeding* **1995**, *1*, 207.
- [64] R. Mittler, *Trends Plant Sci.* **2002**, *7*, 405.
- [65] S. O. Neill, K. S. Gould, P. A. Kilmartin, K. A. Mitchell, K. R. Markham, *Funct. Plant Biol.* **2002**, *29*, 1437.
- [66] M. Gorenšek, M. Gorjanc, V. Bukošek, J. Kovač, Z. Petrović, N. Puač, *Text. Res. J.* **2010**, *80*, 1633.
- [67] D. Mihailović, Z. Šaponjić, R. Molina, N. Puač, P. Jovančić, J. Nedeljković, M. Radetić, *ACS Appl. Mater. Interfaces* **2010**, *2*, 1700.
- [68] I. Filatova, V. Azharonok, V. Lushkevich, A. Zhukovsky, K. Spasić, S. Živković, N. Puač, S. Lazović, G. Malović, Z. Lj. Petrović, Presented at 31st ICPIG, Granada, Spain, July, **2013**.
- [69] N. Puač, Z. Raspopović, Z. Lj. Petrović, Presented at 22nd SPIG, Tara, Serbia, August, **2004**.
- [70] N. Puač, Z. Lj. Petrović, M. Radetić, A. Djordjević, *Mater. Sci. Forum* **2005**, *494*, 291.
- [71] K. Spasić, N. Škoro, N. Puač, G. Malović, Z. Lj. Petrović, Presented at ICOPS, Antalya, Turkey, May, **2015**.
- [72] D. Maletić, N. Puač, N. Selaković, S. Lazović, G. Malović, A. Đorđević, Z. Lj. Petrović, *Plasma Sources Sci. Technol.* **2015**, *24*, 025006.
- [73] D. Maletić, N. Puač, G. Malović, A. Đorđević, Z. L. Petrović, *J. Phys. D: App Phys.* **2017**, *50*, 145202.
- [74] J. Benedikt, S. Hofmann, N. Knake, H. Boettner, R. Reuter, A. von Keudell, V. Schulz-von der Gathen, *Eur. Phys. J. D.* **2010**, *60*, 539.
- [75] M. M. Bradford, *Anal. Biochem.* **1976**, *72*, 248.
- [76] W. Woodbury, A. K. Spencer, M. A. Stahmann, *Anal. Biochem.* **1971**, *44*, 301.
- [77] U. K. Laemmli, *Nature* **1970**, *227*, 680.
- [78] M. D. Abramoff, P. J. Magelhaes, S. J. Ram, *Biophoton. Int.* **2004**, *11*, 36.
- [79] J. D. Moon, H. S. Chung, *J. Electrostat.* **2000**, *48*, 103.
- [80] S. Lynikiene, A. Pozeliene, G. Rutkauskas, *Int. Agrophys.* **2006**, *20*, 195.
- [81] D. Marić, P. Hartmann, G. Malović, Z. Donkó, Z. Lj. Petrović, *J. Phys. D: Appl. Phys.* **2003**, *36*, 2639.
- [82] Z. Giba, D. Grubišić, R. Konjević, in *Nitric Oxide Signaling in Higher Plants*, J. R. Magalhaes, R. P. Singh, L. P. Pasos, (Eds.), Studium Press, LLC, Houston, USA **2004**.
- [83] Ł. Wojtyła, K. Lechowska, S. Kubala, M. Garnczarska, *Front. Plant Sci.* **2016**, *7*, 66.
- [84] H. Nonogaki, G. W. Bassel, J. D. Bewley, *Plant Sci.* **2010**, *179*, 574.
- [85] J. D. Bewley, K. J. Bradford, H. W. Hilhorst, H. Nonogaki, *Seeds*. Springer, New York, USA **2013**.
- [86] C. Bailly, A. Benamar, F. Corbineau, D. Côme, *Seed Sci. Res.* **2000**, *10*, 35.
- [87] J. Bogdanović, K. Radotić, A. Mitrović, *Biologia Plantarum* **2008**, *52*, 396.
- [88] K. Chen, R. Arora, *Plant Sci.* **2011**, *180*, 212.
- [89] K. Apel, H. Hirt, *Annu. Rev. Plant Biol.* **2004**, *55*, 373.
- [90] C. Bailly, A. Benamar, F. Corbineau, D. Come, *Physiol. Plant.* **1998**, *104*, 646.
- [91] J. D. Bewley, *The plant cell* **1997**, *9*, 7, 1055.
- [92] B. Živković, *Master Thesis*, University of Belgrade, Serbia, September, **2006**.
- [93] C. Bailly, J. Leymarie, A. Lehner, S. Rousseau, D. Côme, F. Corbineau, *J. Exp. Bot.* **2004**, *55*, 475.
- [94] S. A. Norberg, W. Tian, E. Johnsen, M. J. Kushner, *J. Phys. D: Appl. Phys.* **2014**, *47*, 475203.
- [95] G. D. Turner, R. R. Lau, D. R. Young, *J. Appl. Ecology* **1988**, *25*, 561.
- [96] B. Chance, *J. Biol. Chem.* **1952**, *194*, 471.
- [97] G. Arabaci, A. Usluoglu, *J. Chem.* **2012**, *2013*, 686185.
- [98] O. Jun-Seok, E. J. Szili, S. Ito, S.-H. Hong, N. Gaur, H. Furuta, R. D. Short and, A. Hatta, *Plasma Med.* **2015**, *5*, 125.
- [99] O. S. Degenhardt, B. Waters, A. Rebelo-Cameirao, A. Meyer, H. Brunner, N. P. Toltl, *Dissolution Technol.* **2004**, *11*, 6.
- [100] V. B. Cardwell, *American Society of Agronomy and the Crop Science Society of America.* **1984**, 53–92.
- [101] C. B. Rajashekar, K-H. Baek, *Am. J. Plant Sci.* **2015**, *2014*, 3572.
- [102] B. Halliwell, J. M. Gutteridge, *Free Radicals in Biology and Medicine*. Oxford University Press, NY, USA **1999**.
- [103] C. Bailly, H. El-Maarouf-Bouteau, F. Corbineau, *C. R. Biol.* **2008**, *331*, 806.

How to cite this article: Puač N, Škoro N, Spasić K, et al. Activity of catalase enzyme in *Paulownia tomentosa* seeds during the process of germination after treatments with low pressure plasma and plasma activated water. *Plasma Process Polym.* 2017;e1700082, <https://doi.org/10.1002/ppap.201700082>

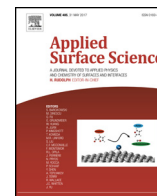

Full Length Article

Plasma treated polyethylene terephthalate for increased embedment of UV-responsive microcapsules



Marija Gorjanc^{a,*}, Miran Mozetič^b, Gregor Primc^b, Alenka Vesel^b, Kosta Spasić^c,
Nevena Puač^c, Zoran Lj. Petrović^c, Mateja Kert^a

^a University of Ljubljana, Faculty of Natural Sciences and Engineering, Aškerčeva 12, SI-1000 Ljubljana, Slovenia

^b Jozef Stefan Institute, Jamova 39, SI-1000 Ljubljana, Slovenia

^c Institute of Physics of Belgrade, Pregrevica 118, 11080 Zemun, Serbia

ARTICLE INFO

Article history:

Received 22 December 2016

Received in revised form 19 April 2017

Accepted 21 April 2017

Available online 24 April 2017

Keywords:

Plasma afterglow

Photochromic microcapsules

UV sensor

Textile

Polyethylene terephthalate

UV-responsive

ABSTRACT

Polyethylene terephthalate (PET) fabric was treated in a late afterglow of plasma created by a microwave (MW) discharge in the surfatron mode, by using oxygen (O₂) and ammonia (NH₃) gases. The series of treatments using one gas or the combination of both at different treatment times were performed in order to increase the embedment of UV-responsive microcapsules that were deposited onto PET with pad-dry-cure process. Plasma in both gases was characterized by optical emission spectroscopy (OES), which showed substantial dissociation of O₂ and NH₃ molecules as well as formation of NH_x radicals due to the partial dissociation of ammonia molecules. The chemically active species in the plasma afterglow changed the surface properties of PET that were analysed using X-ray photoelectron spectroscopy (XPS), time-of-flight secondary ion mass spectrometry (ToF-SIMS), Fourier transform infrared spectroscopy (FTIR), scanning electron microscopy (SEM) and water absorption analysis. The effectiveness of plasma treatment on embedment of UV-responsive microcapsules on PET was evaluated by UV-responsiveness, colour strength and colour depth using reflectance spectroscopy, add-on and air permeability, respectively. Treating PET by O₂ afterglow followed by a longer treatment by NH₃ afterglow increased the polymers hydrophilicity and concentration of nitrogen-rich functional groups on surface that enabled higher uptake of UV-responsive microcapsules, and consequently better responsiveness of fabric to UV radiation. The add-on of microcapsules was almost 8-times higher and the colour depth increased up to 75% for plasma treated samples.

© 2017 Elsevier B.V. All rights reserved.

1. Introduction

One of the main concerns regarding a decrease in stratospheric ozone is the consequential increase in the amount of ultraviolet (UV) radiation, which is harmful for human health and ecosystems [1–3]. Accordingly, different ultraviolet (UV) radiation sensors have been proposed with the growing interest in the research of developing flexible, textile-based UV sensors [4–6]. Due to the phase-change that photochromic dyes undergo when exposed to UV light, which is from colourless to coloured, they are considered suitable to be used as UV sensors [7–9]. When the source of UV radiation is removed, the photochromic dye reverts to its original state. Since photochromic dyes have poor stability to the environmental factors such as oxygen, pH value, light and temperature,

which lead to the oxidation and deterioration, it is preferable to use them in the form of microcapsules [10,11]. One of the promising polymers that could be used as a carrier of photochromic microcapsules is polyethylene terephthalate (PET), which has high tensile strength, stability and resistance to many chemicals, environmental conditions and UV radiation [12]. PET textile with integrated UV-responsive microcapsules would be a simple and user-friendly smart protection. However, the hydrophobic nature of PET results in poor uptake and adhesion of dyes, particles and microcapsules [13–16]. The solution to the problems associated with low absorptiveness and high hydrophobicity of PET is a use of plasma [17–20] to functionalise surfaces of fibres.

Plasma technology is a dry process, which modifies the surface of polymers without changing their bulk properties. According to the desired surface properties of the polymers, it is very important to choose the right discharge parameters [21]. By changing the type of gas, gas flow, power transmitted to the plasma and treatment time one can tune the effects of plasma chemistry on the

* Corresponding author.

E-mail address: marija.gorjanc@ntf.uni-lj.si (M. Gorjanc).

treated surface. For example, when hydrophilic character is desired, the polar functional groups should be introduced by oxygen, air, ammonia or nitrogen discharge gas. The nature and/or concentration of the active species created in plasma depend mostly on the chosen discharge-forming gas [22,23]. The solution to increase the hydrophilic nature of PET is to treat it with oxygen plasma [24–26]. However, for uptake of anionic dyes onto textiles it is preferable that the surface of the material contains amine-containing reactive functional groups [27–29]. Several studies on incorporation of amine-containing groups onto surface of PET by using plasma were conducted with gases such as nitrogen and ammonia, and combination of nitrogen/ammonia or ethylene/ammonia [20,30,31]. Using NH_3 plasma on PET incorporates mainly hydroxyl and amine groups, while using N_2 plasma incorporates mainly carboxylic groups [31]. Treatment of PET films with a combination of N_2/H_2 plasma incorporates higher concentration of nitrogen-containing groups (4.2%) than treatment with NH_3 plasma (2.5%) [32]. However, the treatment with NH_3 plasma resulted in more stable functionalisation of the PET surface. Kolar et al. [33] treated PET films with NH_3 and N_2 plasma, combination of NH_3/Ar plasma and combination of N_2/H_2 plasma. In all cases, the surface of PET was functionalized by nitrogen, the highest when PET was treated with NH_3 plasma (10.6%) and lowest when it was treated with N_2 plasma (2.9%). The density of amino-anchor points was high enough to allow covalent bonding of heparin, an anionic anticoagulant. Salem et al. [29] tried two approaches to increase the uptake of anionic dye onto PET fabric. In the first approach, nitrogen-containing groups were incorporated using NH_3 plasma. In the second approach surface of the PET was first treated with oxygen plasma to introduce negatively charged groups as anchors for cationic polyelectrolyte. It was found that the second approach was more successful in increasing the uptake of anionic dye onto PET.

The objective of present work was to investigate combination of surface treatments of PET fabric by oxygen and ammonia plasma, with an aim to increase the uptake of anionic photochromic microcapsules onto fabric and consequently to increase its UV-responsiveness. The findings of this research could be further used for production of smart and flexible UV sensors.

2. Experimental

2.1. Materials

Polyethylene terephthalate (PET) bleached fabric, UV-responsive microcapsules containing photochromic dye ITOFINISH UV and binder ITOBINDER AG (LJ SPECIALITIES LTD.) were used. ITOFINISH UV is a light sensitive coloured dye giving reversible colour change due to the effect of the UV light. ITOBINDER AG is water based emulsion of acrylic polymer.

2.2. Surface functionalization

Polymer samples were treated in a late afterglow of plasma created by using a microwave (MW) plasma source in the surfatron mode. The plasma source was mounted onto a glass vacuum chamber 30 L in volume. The processing chamber was pumped by a two-stage rotary pump of nominal pumping speed $60 \text{ m}^3/\text{h}$. The pressure was measured with an absolute gauge attached to the processing chamber. Oxygen and ammonia of purity 99.99% were introduced separately into the processing chamber through flow controllers and the discharge tubes. Samples were placed into the center of the processing chamber, but slightly off the main stream of gas flow. After placing a sample, the processing chamber was evacuated to the ultimate pressure which was about 3 Pa. When the ultimate pressure was reached (about a minute of pumping)

the flow of gases was adjusted using a flow meter for oxygen and a precise needle valve for ammonia. We selected the flow of 220 sccm for oxygen. Continuous pumping at one side and gas inlet at the other, allowed us to establish a constant pressure of 40 Pa in the processing chamber. The microwave discharge was ignited 8.5 cm above the chamber containing the sample. Gases were radicalized by passing through the microwave discharge. The charged particles created in plasma within the discharge zone were effectively neutralized on the way from the glowing plasma to the entrance of the processing chamber, while the neutral radicals remained fairly intact since the gas-phase recombination was negligible at the low pressure conditions and the surface effects were minimized by using the inert material (glass). The residence time of gas in the afterglow chamber is estimated from the pumping speed and geometry of the vacuum system. In a rough approximation it is 0.1 s. The life-time of oxygen atoms in the chamber at steady conditions, i.e. without continuous gas inlet and pumping the system, was estimated for the case plasma was ignited in the chamber by DC glow discharge. A catalytic probe of high temporal sensitivity was mounted into the chamber and the O-atom density was measured after turning off the discharge. The resultant life-time was about 1.5 s. The samples mounted in the processing chamber were therefore treated by neutral reactive particles formed in the gaseous plasma inside the microwave discharge – predominantly oxygen atoms in the ground state (in the case of oxygen plasma) and NH_x radicals as well as atomic hydrogen in the ground state (in the case of ammonia plasma). The applied discharge power was 150 W.

2.3. Plasma characterization

Plasma in the microwave discharge was characterized by using optical emission spectroscopy (OES). Optical emission spectra were recorded by using an Avantes Ava Spec 3648 spectrometer. The device is based on an Ava Bench 75 symmetrical Czerny Turner design with a 3648 pixel CCD detector with the focal length of 75 mm. The range of measurable wavelengths is from 200 nm–1100 nm and the wavelength resolution is 0.5 nm. The spectrometer has a USB 2.0 interface, enabling high sampling rates of up to 270 spectra per second, in which the Signal-to-noise ratio is 350:1. Integration times are adjustable from $10 \mu\text{s}$ to 10 min. At integration times below 3.7 ms, the spectrometer itself performs internal averaging of spectra before transmitting them through the USB interface. A fixed integration time of 2 s was used. Such time enabled sufficient signal intensity and enough measurement points for measuring time evolution of certain spectral features. The optical fibre was mounted 1 cm away from the discharge tube.

2.4. Residual gas analysis

A standard residual gas analyser based on mass spectrometry of the atmosphere in the reaction chamber was applied. The spectrometer was connected to the chamber via a glass capillary of low conductance allowing for appropriate pressure of the order of 10^{-3} Pa in the spectrometer. The spectrometer was pumped differentially using a turbomolecular pump of nominal pumping speed 500 l/s backed by a two-stage rotary pump.

2.5. Loading of UV-responsive microcapsules

UV-responsive microcapsules were loaded on untreated and plasma-treated PET samples using pad-dry-cure method. The PET samples were submerged in the solution containing 50 g/l of UV-responsive microcapsules and 50 g/l of binder. The excess of coating was squeezed out in the rollers of laboratory foulard, with pick-up of 100%. Afterwards the PET samples were dried for 5 min at 100°C

and cured for 3 min at 150 °C. The add-on (Ad) of microcapsule-coated samples was calculated according to the Eq. (1):

$$Ad(\%) = \frac{(m_{\text{coated}} - m_{\text{uncoated}})}{m_{\text{uncoated}}} \times 100 \quad (1)$$

2.6. X-ray photoelectron spectroscopy

The surface composition of untreated and plasma-treated samples was studied using high-resolution X-ray photoelectron spectroscopy (XPS). The samples were mounted in a TFA XPS Physical Electronics XPS instrument. The base pressure in the XPS analysis chamber was approximately 6×10^{-8} Pa. The samples were excited with X-rays over a 400 μm spot with monochromatic Al $K_{\alpha 1,2}$ radiation at 1,486.6 eV. The photoelectrons were detected with a hemispherical analyser positioned at an angle of 45° normal to the sample surface. The energy resolution was approximately 0.5 eV. Survey-scan spectra were acquired at a pass energy of 187.85 eV with a 0.1 eV energy step. An additional electron gun was used to allow for surface neutralisation during the measurements because the samples were insulating. The concentration of the different elements was determined using MultiPak v8.1c software from Physical Electronics, which was supplied with the spectrometer.

2.7. Fourier transform infrared spectroscopy (FTIR)

ATR-FTIR spectra of untreated and plasma-treated samples were acquired using FTIR spectrophotometer (Bruker IFS 66/S). The spectra were collected from samples, which were tightly pressed against a cylindrical Ge crystal. The resolution of the equipment was 4 cm^{-1} with 64 scans and the spectra were obtained over the range of 4000 cm^{-1} –600 cm^{-1} .

2.8. Time-of-flight secondary ion mass spectrometry (ToF-SIMS)

ToF-SIMS analyses were performed using a ToF-SIMS 5 instrument (ION-TOF, Münster, Germany) equipped with a bismuth liquid metal ion gun with a kinetic energy of 30 keV. The analyses were performed in an ultra-high vacuum of approximately 10⁻⁷ Pa. The SIMS spectra were measured by scanning a Bi₃⁺ cluster ion beam with a diameter of 1 μm over a 100 \times 100 μm^2 analysis area. The positive secondary ion mass spectra were calibrated using CH₂⁺, CH₃⁺, and C₂H₅⁺, and the negative secondary ion mass spectra were calibrated using C⁻, C₂⁻, and C₃⁻. An electron gun was used to enable charge compensation on the sample surfaces during the analysis.

2.9. Absorption of water

The untreated and plasma-treated PET fabrics were tested for water absorbency according to AATCC Test Method 39-1980 in order to evaluate the changes in hydrophobic character of PET samples after plasma treatment. A water droplet was carefully deposited on the surface of PET fabric and the time between the contact of the water droplet with the fabric and the disappearance of the droplet into the fabric was measured in seconds (wetting time). The average of measurements for five water drops on one substrate was calculated.

2.10. Measurements of UV-responsiveness

The untreated and plasma-treated PET samples coated with UV-responsive microcapsules were tested for their UV-responsiveness using reflectance spectrophotometer SF 600 PLUS-CT (Datacolor, Switzerland). The specular component of the spectrophotometer

was included, UV filter excluded (FL40: 0% UV), measurements were performed under illumination D65 and 10° standard observer. The samples were folded twice to gain four-layered thickness of the material. The CIELAB colour values and light reflectance (R[%]) were measured prior and after 1 min irradiation with UV light source (Philips UVA type bulb, 2 \times 18 W), at the distance of 15 cm.

The colour difference (ΔE_{ab}^*) between non-irradiated and UV irradiated sample was calculated using Eq. (2):

$$\Delta E_{ab}^* = \sqrt{\Delta L^{*2} + \Delta a^{*2} + \Delta b^{*2}}, \quad (2)$$

where ΔL^* is a difference in lightness, Δa^* is a difference on red-green axis and Δb^* is a difference on yellow-blue axis.

2.11. Measurements of colour strength

The colour strength (K/S values) of irradiated samples was calculated from the reflectance (R) values at wavelength of visible spectra, from 400 nm to 700 nm, using the following equation:

$$\frac{K}{S} = \frac{(1 - R)^2}{2R}, \quad (3)$$

where K is absorption coefficient, S is scattering coefficient and R is reflectance factor.

The percentage of improvement in colour depth (I) was calculated according to the Eq. (4):

$$I(\%) = \frac{(K/S_{\text{treated}} - K/S_{\text{untreated}})}{K/S_{\text{untreated}}} \times 100, \quad (4)$$

where K/S_{treated} is a colour strength of plasma-treated microcapsule-coated PET sample and $K/S_{\text{untreated}}$ is a colour strength of untreated microcapsule-coated PET sample.

2.12. Air permeability

The air permeability of uncoated and microcapsule-coated samples was determined according to the standard ISO 9237:1999, using AirTronic 3240A air permeability tester (MESDAN), at pressure drop 100 Pa. The air permeability (mm/s) was calculated according to the Eq. (5):

$$R = \frac{q_v}{A} \times 167, \quad (5)$$

where q_v is the arithmetic mean flow rate of air (L/min), A is the area of sample under test (cm^2), 167 is the conversion factor from L/min to mm/s.

3. Results and discussion

A series of treatments in MW plasma late afterglow were performed to determine the best conditions to achieve a greater uptake of PET fabric towards microcapsules containing photochromic dye and consequently to increase the UV-responsiveness of the fabric. The parameters that were varied in the research were gases used for producing chemically reactive species in plasma afterglow or combination of gases, namely oxygen (O₂) and ammonia (NH₃), and different treatment times. Plasma was characterized by OES, while the influence of the plasma afterglow treatments on the PET fabric was evaluated using XPS, SEM and wetting time.

Figs. 1 and 2 represent optical spectra of plasma created in oxygen and ammonia, respectively. The optical spectra of plasma created in oxygen, are typical for plasma with high dissociation fraction of oxygen molecules. Almost exclusively atomic oxygen lines are observed in the spectrum presented in Fig. 1 (a small peak at 760 nm represents O₂ molecular transition). The oxygen lines arise from the transition between highly excited atoms at excitation energy above 10 eV to lower excited states. The excited

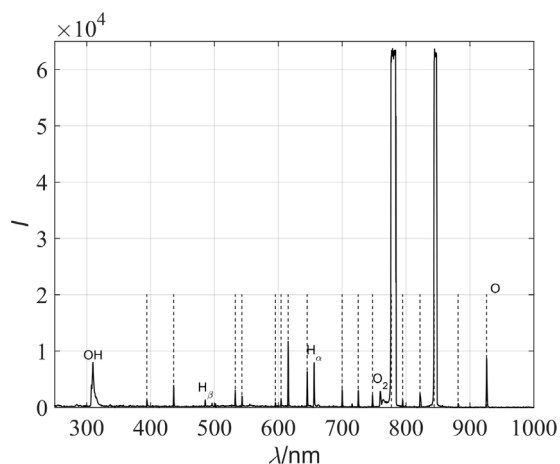

Fig. 1. An optical spectrum of oxygen plasma acquired in the discharge tube.

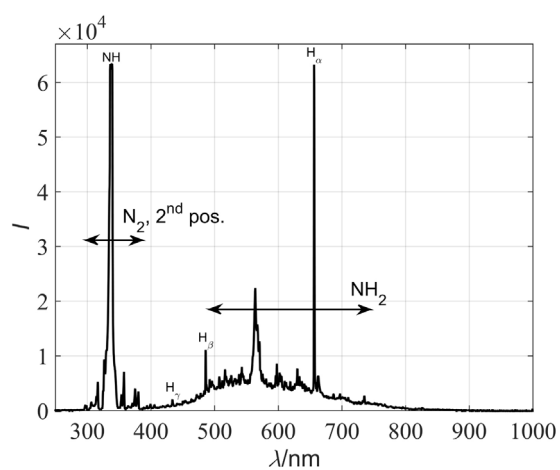

Fig. 2. An optical spectrum of ammonia plasma acquired in the discharge tube.

atoms mostly produced through dissociative excitation relax on the way to the processing chamber where only oxygen atoms in the ground state are present along with the molecules that might be excited to metastable states. There are also emission lines from atomic hydrogen in the visible range and the band corresponding to radiative relaxation of the OH radicals at the bandhead of 309 nm. The appearance of these spectral features is attributed to the residual atmosphere, which contains practically only water vapour in such experimental systems. As stated in subsection 2.1 the ultimate pressure is about 3 Pa what is several% of the total pressure. The water molecules diffuse also into the discharge tube and contribute to the optical spectrum presented in Fig. 1. No emission from nitrogen (ionized or neutral) is observed in the spectrum thus one can conclude the system is hermetically tight.

The samples were treated in oxygen plasma afterglow, where the main reactants are neutral atoms in the ground state, which interact chemically with polymer materials resulting in functionalisation of polymer surfaces with polar functional groups [21]. Such a treatment using only neutral reactive particles is preferred since it causes better functionalisation than conventional plasma treatment for various polymers including PET [34].

Fig. 2 represents an optical spectrum of plasma created by the microwave discharge in ammonia. The spectrum is rich in atomic hydrogen transitions that belong to the Balmer series (particularly H_{α}). Apart from these transitions an intensive peak is observed in the near UV range at the wavelength of 336 nm. This peak corresponds to the transition of the NH radical from $A^3\Pi$ (excited) to

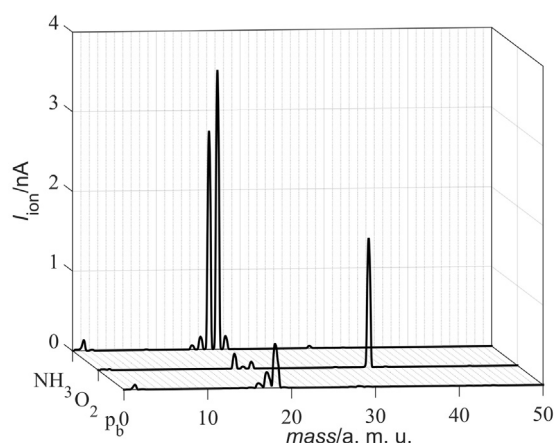

Fig. 3. Mass spectra of residual atmosphere during base pressure (p_b), oxygen inlet (O_2) and during ammonia inlet (NH_3).

Table 1

The XPS surface composition of the untreated and plasma-treated PET fabrics (in atomic%).

Sample treatment	C	N	O	O/C	N/C
Untreated	76.3	0	23.7	0.31	–
100 s O_2	62.8	0	37.2	0.59	–
100 s NH_3	73.6	0.8	25.6	0.34	0.01
100 s O_2 + 3 s NH_3	61.1	2.5	36.4	0.60	0.04
100 s O_2 + 81 s NH_3	60.4	3.3	36.4	0.60	0.05
100 s O_2 + 243 s NH_3	59.2	4.6	36.3	0.61	0.08
200 s O_2 + 243 s NH_3	58.7	5.0	36.3	0.62	0.09

$X^3\Sigma^-$ (ground) state. Apart from these spectral features there are also broad bands in the visible range between roughly 450 and 750 nm that correspond to radiative relaxation of NH_2 radicals. The spectrum presented in Fig. 2 indicates extensive dissociation of ammonia molecules. The dissociation results in formation of atomic hydrogen and NH_x radicals. The radicals do not recombine much on the way from plasma to the processing chamber due to low pressure conditions (lack of three-body collisions which otherwise cause loss of radicals in the gas phase) and selection of the chamber material (glass is an inert material that does not allow for extensive surface recombination of H atoms to H_2 molecules [35]).

Fig. 3 represents the mass spectrum at the ultimate pressure as measured by residual gas analyser. The peak at 18 represents water vapour while the peaks at 17, 16 and 2 the dissociation products, i.e. OH, O and H_2 . The water molecules partially dissociate upon interaction with the electrons used for ionization of gaseous molecules in the gas analyser. No measurable amount of other molecules is observed; therefore, the system is rather hermetically tight. Intentional introduction of oxygen is reflected in appearance of the peak at 32 (O_2) as well as relative increase of the peak at 16 (O). The relative intensity of peaks arising from water vapour decrease as shown in Fig. 3. This results are highly expecting due to high purity of oxygen. More interesting is the mass spectrum for the case when ammonia was introduced into the system, which is presented in Fig. 3. In this case we observe intensive peaks at 17 and 16 corresponding to NH_3 and NH_2 , respectively, but the peak at 18 still persists indicating measurable amount of water vapour in the system during treatment of samples with ammonia afterglow. The small peak at 28 (N_2) is due to recombination of N atoms to parent molecules in the mass spectrometer rather than any inlet of air into the vacuum system.

The chemical changes on the surface of PET fabrics after plasma afterglow treatment are presented in Table 1. The untreated sample has a high concentration of carbon and low concentration of oxy-

gen as expected from the chemical composition of this polymer. The ratio between oxygen and carbon is 0.31. Treating PET sample with MW afterglow produced in oxygen gas increases the concentration of oxygen and decreases concentration of carbon on the surface of PET polymer (ratio O/C is 0.59) indicating saturation of the polymer surface with polar functional groups. Here, it is worth mentioning that the characterization depth of XPS using the classical source of X-rays is several nm so the result presented in Table 1 does not reflect the composition on the very surface but rather an average composition over the thickness of the surface film that corresponds to the escape depth of photoelectrons. Treating PET by the MW afterglow produced using only ammonia gas does not significantly change the chemical composition of the surface layer. The oxygen content is increased slightly so that the ratio O/C is 0.34 after treatment with ammonia plasma afterglow for 100 s. Such an increase could be attributed either to the experimental error or the fact that the processing chamber was not pumped down to a high-vacuum level but rather to the pressure of about 3 Pa. The residual atmosphere in the vacuum system contains predominantly water vapour (Fig. 3) whose molecules dissociate inside plasma forming OH radicals that are known to be excellent oxidants for organic materials. The optical spectrum presented in Fig. 1 clearly shows presence of such radicals. Unfortunately, in Fig. 2 the main OH band partially overlaps with the N₂ second positive band, therefore it is not as distinguished as in Fig. 1. The solid confirmation of the rather high concentration of water vapour in the experimental chamber during treatment of samples with ammonia afterglow is presented in Fig. 3. The OH radicals therefore cause some increase of the oxygen concentration on the polymer surface upon treatment with the ammonia afterglow. Appearance of nitrogen is observed on the polymer surface after treatment in ammonia plasma afterglow as the PET surface layer contains about 0.8 atomic% of nitrogen. Such a poor functionalization is explained by rather high stability of PET materials. Obviously, the atomic hydrogen created in the processing chamber is not capable to remove oxygen from the surface of polyethylene terephthalate at room temperature thus giving way to chemical bonding of nitrogen-containing groups. Such resistance of PET against atomic hydrogen at room temperature has been already observed so only application of rather dense hydrogen plasma rich in hydrogen ions as well as UV radiation allows for reducing oxygen content in the polymer surface [36]. The treatment of PET samples in late afterglow of ammonia plasma therefore does not allow for binding substantial amount of nitrogen (preferably in the form of amino groups) that would allow for appropriate surface finish prior to functionalisation with the UV-responsive microcapsules. That is why we have used a combination of oxygen and ammonia afterglows. The oxygen pre-treated sample treated with ammonia plasma afterglow for solely 3 s allowed for concentration of nitrogen in the surface film examined by XPS of about 2.5 atomic% (Table 1). Prolonged treatment causes even better functionalization since the achievable concentration of nitrogen is almost 5 atomic%. Numerous different functional groups may form upon treatment of polymers with reactive species from ammonia plasma but the afterglow of ammonia plasma is particularly suitable for formation of amino groups. The results presented in Table 1 are explained by increased affinity of pre-treated PET for binding nitrogen-containing radicals. The pre-treatment by oxygen atoms allows for saturation of PET surface with highly polar functional groups that are rather unstable. Such functional groups interact with H and NH_x radicals from ammonia plasma causing partial reduction of the surface film as well as functionalization with nitrogen functional groups. The reduction probably occurs only on the very surface and not in the sub-surface layers. This could be a feasible explanation for observations presented in Table 1. Namely, the concentration of oxygen in the surface film examined by XPS is reduced only marginally even after prolonged treatment with

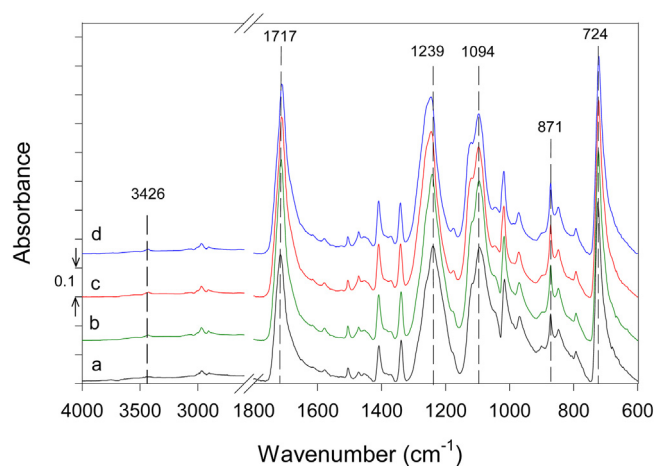

Fig. 4. FTIR spectra of untreated (a) oxygen plasma treated (b), ammonia plasma treated (c), oxygen and ammonia plasma-treated polyester (d).

late afterglow of ammonia plasma. The concentration of oxygen on samples treated by oxygen afterglow is 37 atomic% while on the samples treated first by oxygen and then ammonia afterglow is about 36 atomic% irrespective of the treatment time. Taking into account this fact one can speculate that nitrogen in the surface of our samples is bonded to carbon atoms in amide or similar oxygen-containing groups rather than amino groups. The type of the groups, however, cannot be determined by XPS due to overlapping of subpeaks in high-resolution carbon C1s peak corresponding to different surface functional groups.

To get more information about the type of nitrogen functional groups, we performed additional characterisation using Fourier transform infrared spectroscopy (FTIR) and time-of-flight secondary ion mass spectrometry (ToF-SIMS). In Fig. 4 FTIR spectra of untreated and plasma-treated PET fabric are presented. The characteristic absorption bands of PET are visible at 1717 cm⁻¹ (C=O stretching of aromatic ester), 1239 cm⁻¹ (asymmetric stretching of aromatic ester), 1094 cm⁻¹ (aromatic ester O=C–O–C vibration), 871 cm⁻¹ (vibrations of aromatic ring) and 724 cm⁻¹ (C=O out-of-plane bending and ring CH out-of-plane bending), whilst the three small absorption bands between 2988 cm⁻¹ and 2935 cm⁻¹ belong to C–H sp³ vibrations [37,38]. The appearance of oxygen-rich groups on PET surface such as CO, COO, OH etc. as a consequence of O₂ plasma treatment make PET surface more hydrophilic and therefore more water molecules can be absorbed. The latter can be observed in FTIR spectra of O₂ plasma-treated PET as the appearance of absorption band at 3421 cm⁻¹, assigned to intermolecular O–H bonded to C=O in the polyester chain, comparing to the untreated PET [39]. Additionally, the increase of intensity of the absorption band and its broadening at 1717 cm⁻¹, assigned to carbonyl C=O vibration is also observed after O₂ plasma treatment [40,41]. After NH₃ plasma treatment the IR spectroscopy showed no signs of amination, what is in sound with our XPS conclusions about absence of amino groups. Another reason can be also higher detection depth of FTIR and thus too low surface sensitivity. Therefore, SIMS which is a technique with very high surface sensitivity can give better information regarding surface functionalities.

In Fig. 5 are shown negative SIMS spectra of untreated PET and the one treated in combination of oxygen and ammonia plasma. In the spectrum of the untreated PET there are peaks that correspond to characteristic molecular fragments of PET material. After plasma treatment, two new peaks are observed at m/z 26 and m/z 42 that correspond to CN⁻ and OCN⁻ fragments. The ratio OCN⁻/CN⁻ is 0.57. It was reported by Gerenser et al. [42] that OCN⁻/CN⁻ ratio is an important indicator of the type of nitrogen-containing polymers.

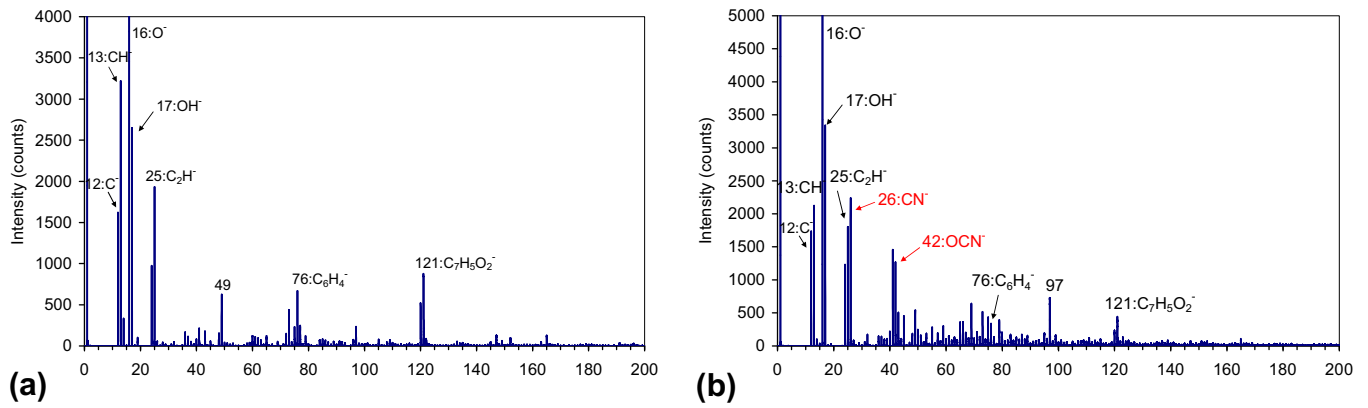

Fig. 5. Negative SIMS spectrum of: (a) untreated sample and (b) oxygen and ammonia plasma-treated sample.

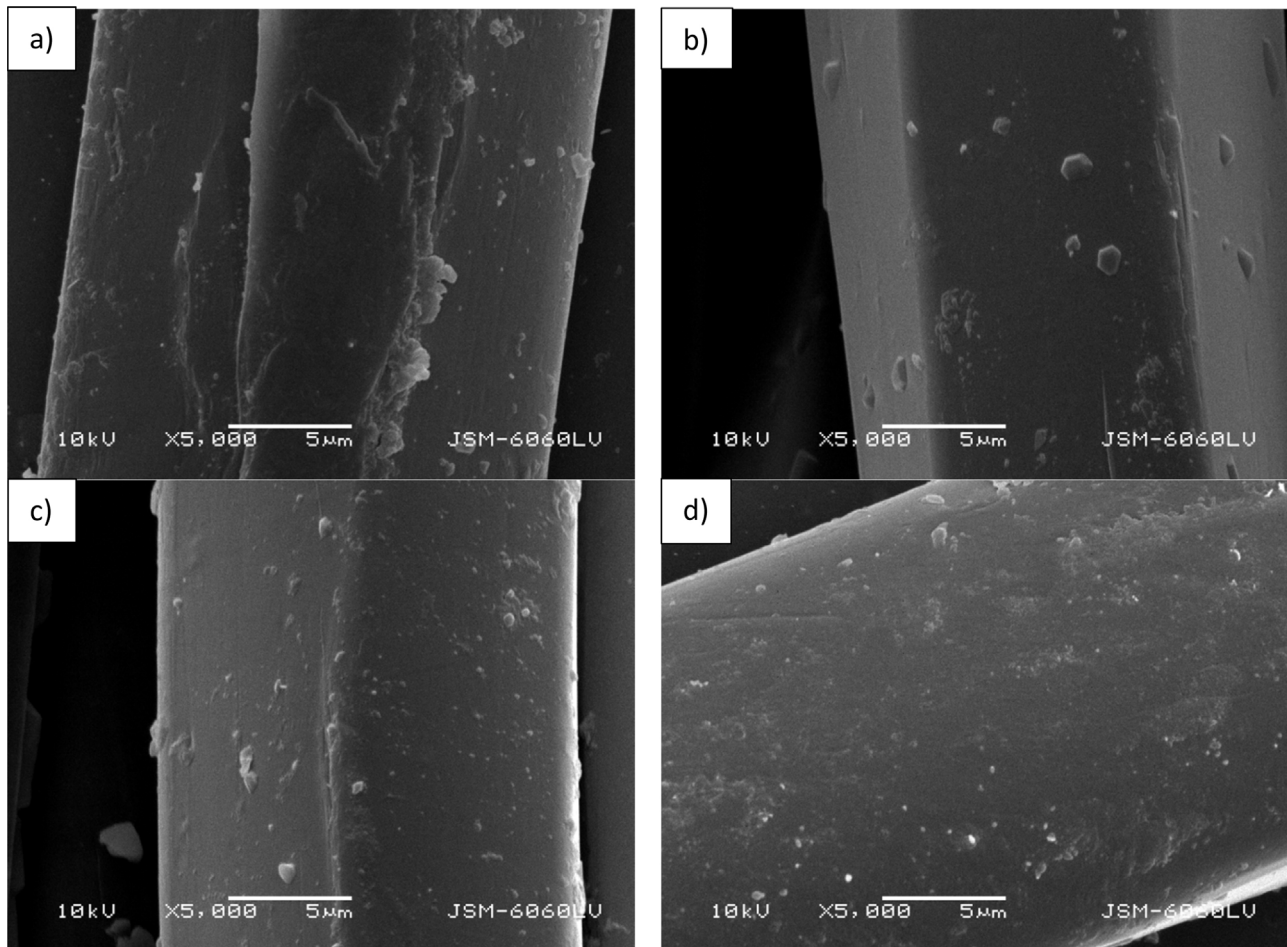

Fig. 6. The SEM images of PET samples (a) untreated, (b) treated with 100 s O₂ and 3 s NH₃ plasma afterglow, (c) treated with 100 s O₂ and 243 s NH₃ plasma afterglow, (d) treated with 200 s O₂ and 243 s NH₃ plasma afterglow.

The reported ratio for amines and imines was <0.05, for imides 0.19, for amines 0.22 and for urethanes it was 1.25. Our value of 0.57 suggests that nitrogen groups are associated with oxidized carbon and thus they support our conclusions derived from XPS results.

The water absorption analysis was performed on untreated and plasma-treated samples to evaluate the hydrophilic/hydrophobic character of PET fabric. The results summarized in Table 2 show a dramatic improvement of the water sorption after the treatments. The untreated PET fabric is moderately hydrophobic so the absorption time is almost a minute. As expected, the oxygen plasma-treated samples exhibit a hydrophilic character – the

Table 2
Water absorption of untreated and plasma-treated PET fabrics.

Sample treatment	Absorption time (s)
Untreated	54.5
100 s O ₂	0.35
100 s O ₂ + 100 s NH ₃	0.95
100 s NH ₃	28.13

absorption time is well below a second. Such a fast absorption is explained by functionalization of the polymer surface with polar oxygen-rich functional groups. Interesting enough, the absorp-

tion time remains short even after functionalization with nitrogen groups. The absorption time for the sample treated first by oxygen plasma afterglow and then by radicals from ammonia plasma is about 1 s. This is three times longer than for only oxygen-treated sample but still much shorter than for untreated sample. Such a short absorption time presented in Table 2 indicates that the sample retained hydrophilic character despite functionalization with nitrogen functional groups. Table 1 reveals that also the high concentration of oxygen on the sample treated subsequently by oxygen and ammonia plasma afterglows persists. The results presented in Tables 1 and 2 are therefore sound and just indicate that the method described in this paper allows for both functionalization with nitrogen and hydrophilic character of the sample. The combination of both is beneficial for binding the UV-responsive microcapsules.

In Fig. 6 SEM images of untreated and plasma-treated PET samples are presented, where the influence of plasma treatment on morphological changes of PET fibres is visible. On the untreated sample impurities on the surface of the fibres are present (Fig. 6a), which are removed after treatment with plasma afterglows (Fig. 6b–d). With the increasing treatment time, the cleaning of the surface is greater. In addition to the cleaning, treating PET fabric with 200s O₂ and 243s NH₃ plasma afterglow causes the surface etching effect, modifying the surface of fibres to be rougher (Fig. 6d).

The physical and chemical surface changes induced by plasma afterglow modification influence the uptake capacity of PET fabric towards microcapsules containing photochromic dye, which can be demonstrated by SEM, air permeability, add-on and colour measurements. The SEM images of microcapsule-coated PET fabrics show that treating PET fabric with plasma afterglow, regardless of the gas used, increases the uptake of microcapsules on the surface (Fig. 7). Samples modified at longer treatment time (Fig. 7c) have visibly higher amount of microcapsules embedded on the surface than samples modified at shorter treatment time (Fig. 7b) or untreated samples (Fig. 7a). The following can be expected since untreated PET fabric is hydrophobic with lower content of polar groups and does not wet in such extent as hydrophilic fabric like cotton. Also the microcapsule shell is usually not an agent that can react with the fibre, except microcapsule with reactive group in its shell which can be covalently bonded to fibre functional groups. For that reason, the binding agent is needed in the padding bath, which is responsible for the adhesion of microcapsules onto fabric. Wetting of fabric is especially important and desired at pad-dry process, because the fabric has to pick up the padding bath in a very short time in comparison with exhaust process at which the fabric is immersed in the bath during the whole process and the colorant exhausts gradually onto fabric. When the fibre hydrophilicity is increased, the wetting of fabric is faster and thus uptake of microcapsules can occur to a greater extent.

The results of SEM are in accordance to the results of air permeability (Fig. 8a) and add-on (Fig. 8b). Higher amount of the microcapsules on the plasma-treated samples lowered the permeability and increased the add-on. The air permeability of O₂ and NH₃ plasma treated microcapsule-coated sample is 2.13% and 3.21% lower than of untreated microcapsule-coated sample. As the treatment time with NH₃ plasma prolongs for the O₂+NH₃ plasma-treated PET samples, the air permeability decreases further, up to 9.56%. Higher amount of microcapsules on plasma-treated samples seal the interstices between the fibres, reducing the air permeability [43]. The sample (200sO₂ + 243sNH₃) with lowest air permeability had also the highest add-on (Fig. 11). The add-on on the sample 200sO₂ + 243sNH₃ was 10.75% and on the untreated sample 1.31%, meaning that the add-on on plasma-treated sample was almost eight times higher.

The increased uptake of UV-responsive microcapsules on plasma-treated PET fabric is also determined by UV responsive-

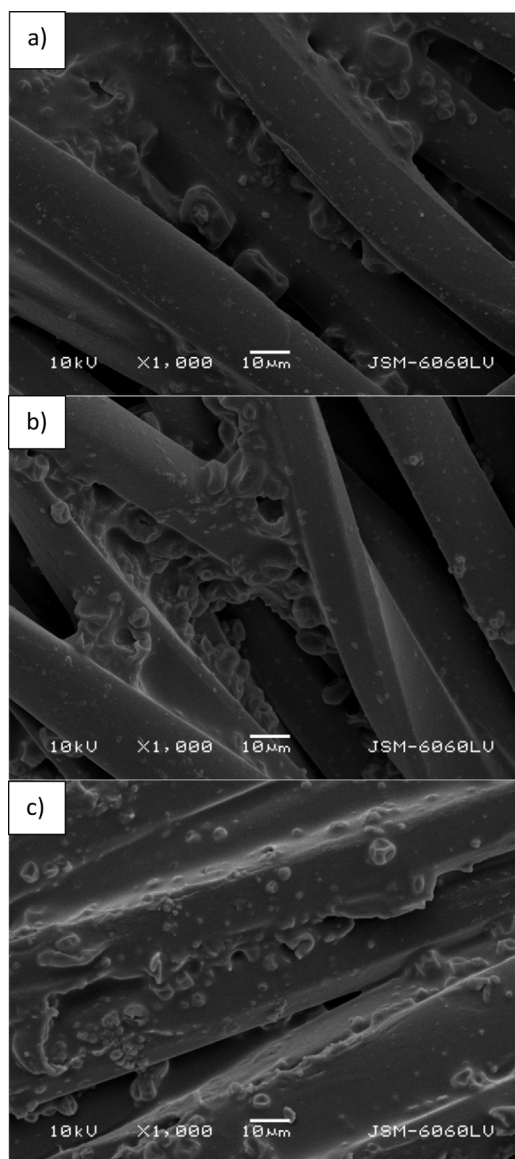

Fig. 7. The SEM images of (a) untreated, (b) treated with 100s O₂ and 243s NH₃ plasma afterglow, (c) treated with 200s O₂ and 243s NH₃ plasma afterglow microcapsule-coated PET fabric.

ness of the fabric upon UV light irradiation and colour difference (ΔE^*_{ab}) between untreated and plasma-treated sample. The UV responsiveness of microcapsule-coated PET fabric was evaluated by colour measurements (CIE L*a*b* values), colour strength (K/S) and percentage of improvement in colour depth (I). The CIE L*a*b* values (Fig. 9) are presented for microcapsule-coated PET samples before and after illumination with UV light source for 1 min. The illuminated samples are darker, bluer and greener compared to unilluminated samples. The plasma-treated samples before the illumination with UV source are slightly darker, slightly greener (moving towards negative CIE a* axis) and yellower (moving toward the positive CIE b* axis). The plasma-treated samples after illumination with UV source are darker (CIE L* values decrease), slightly greener (moving towards negative CIE a* axis) and bluer (moving towards negative CIE b* axis). Regardless of the used gas or combination of both, the plasma treated samples are darker and bluer than untreated samples. The important indicator of photochromic performance of microcapsules on PET fabric is a photo-colouration, which is expressed as colour difference value (ΔE^*_{ab}) between non-irradiated (background colour)

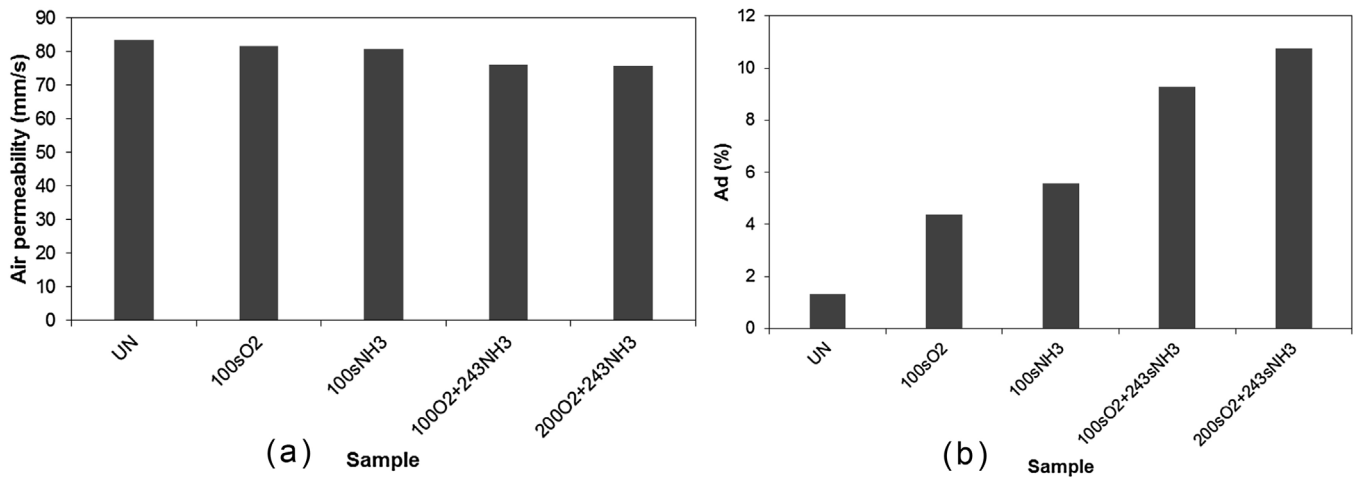

Fig. 8. Air permeability (a) and Add-on (b) of untreated and plasma-treated microcapsule-coated PET samples.

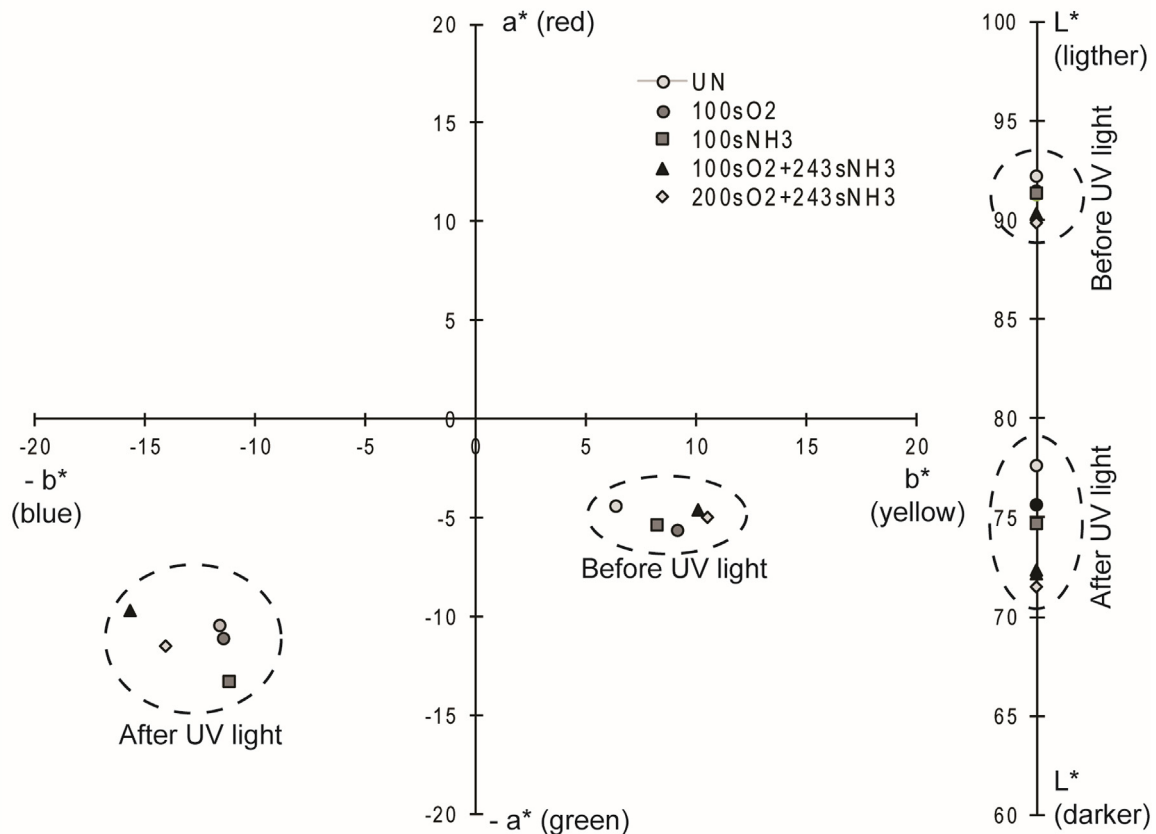

Fig. 9. CIE L*a*b* colour values of untreated and plasma-treated microcapsule-coated PET fabrics, before and after an illumination with UV light source.

and UV irradiated sample (developed colour) [44]. Higher ΔE^*_{ab} values indicate higher ability of photochromic dye to rearrange the bonding between atoms within colourless molecule creating a structure that is intensely coloured. In other words, higher ΔE^*_{ab} values represent better ability of photochromic dye to develop colour after exposure to UV radiation, or in our case higher uptake of microcapsules on PET fabric. After treating PET fabric by plasma afterglow, regardless of the gas used, the ΔE^*_{ab} values increase (Fig. 10a). The PET fabrics treated by 100 s O₂ or 100 s NH₃ afterglow have very similar ΔE^*_{ab} values, indicating that the fabrics have the same UV-responsive performance, which is in both cases higher than of the untreated sample. In Fig. 10b the values of colour differ-

ence between untreated and plasma-treated microcapsule-coated PET samples after illumination with UV source are presented. The ΔE^*_{ab} values range from 2 to 7, meaning that the difference in colour between untreated and plasma-treated sample is visible to the human eye. Highest ΔE^*_{ab} values between untreated and plasma-treated samples were calculated for samples with higher concentration of nitrogen on the surface (Table 1), which is an indication of higher uptake of microcapsules on PET fabric after longer period of treatment by NH₃ MW afterglow.

The results of CIE L*a*b* (Fig. 9) and ΔE^*_{ab} (Fig. 10) are already very good indicators for determination of the uptake capacity of PET fabric towards microcapsules containing photochromic dye. The

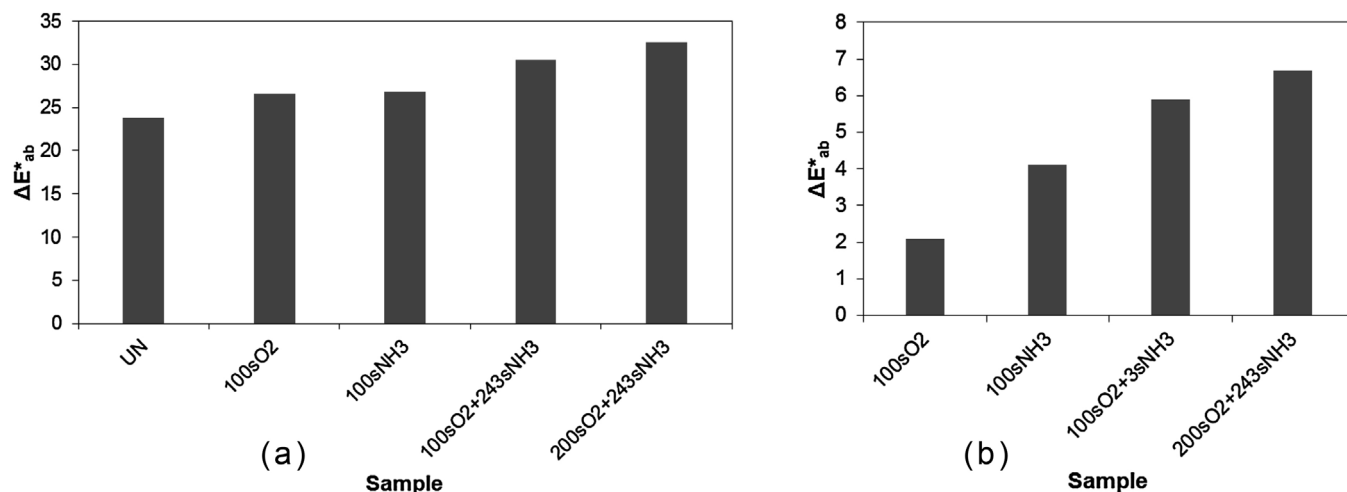

Fig. 10. The colour difference (ΔE^*_{ab}) value microcapsule-coated PET samples (a) between non-irradiated (background colour) and UV irradiated sample (developed colour) and (b) between untreated and plasma-treated UV irradiated samples.

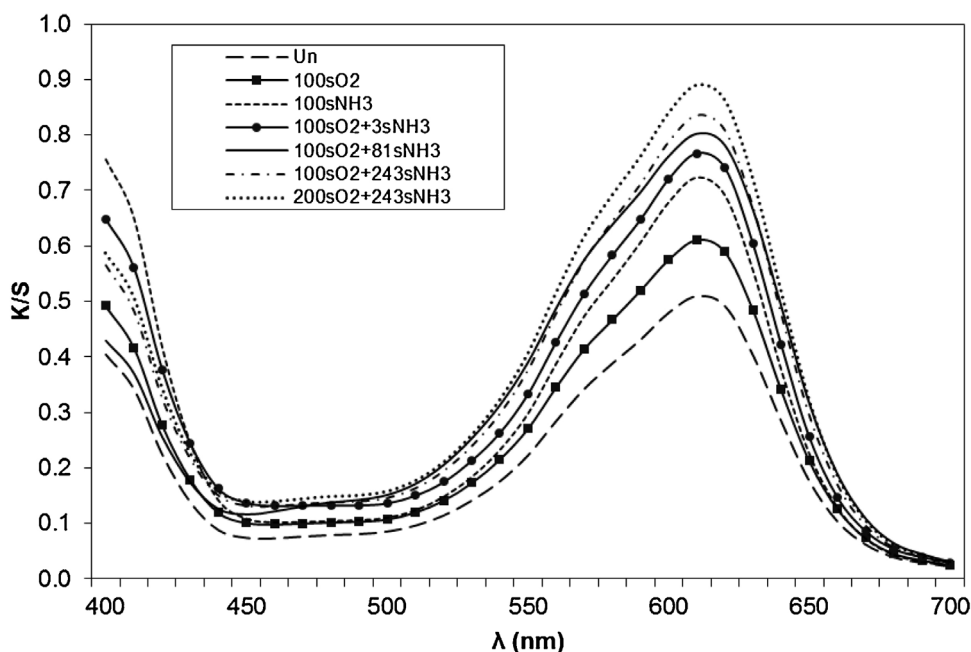

Fig. 11. Colour strength (K/S) values of untreated and plasma-treated microcapsule-coated PET samples after illumination with UV light source.

results of colour strength (K/S) values (Fig. 11) and percentage of improvement in colour depth (I) (Fig. 12) prove that MW afterglow treatment indeed increases the uptake of photochromic microcapsules onto PET fabric. The colour strength (K/S) describes the reflectance and transmittance of a translucent sample as a function of the light absorption and the light scattering in the sample [45]. The absorption of the light is proportional to the concentration of the colorant on the textile. Higher K/S value means that the sample contains higher amount of the colorant (in our case photochromic dye). The results of K/S values (Fig. 11) show that treating PET fabric with plasma increases the intensity of K/S peaks at wavelength of 610 nm. Higher peaks of K/S values are correlated with a higher quantity of UV-responsive microcapsules on the PET sample. The PET fabric treated with the NH₃ MW afterglow has higher uptake capacity towards microcapsules than PET fabric treated with O₂ MW afterglow. Also, the intensity of K/S peaks increase for samples treated by MW afterglow where a combination of gases was used. The K/S values increase with longer treatment time with NH₃

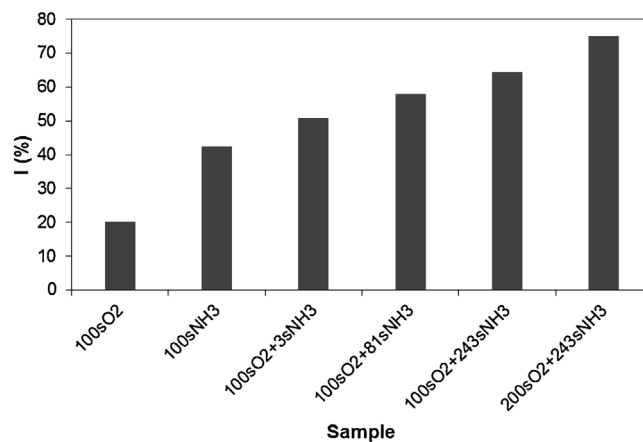

Fig. 12. The percentage of improvement in colour depth (I) between untreated and plasma-treated microcapsule-coated PET samples.

afterglow, and the highest increase of K/S values were obtained for a sample treated by 200 s O₂ and 243 s NH₃ plasma afterglow.

The results of percentage of improvement in colour depth (Fig. 12) between untreated and plasma-treated microcapsule-coated PET samples indicate that the improvement in colour strength (K/S) is almost 20% higher after treatment with O₂ plasma, and almost 75% for sample treated for 200 s with O₂ plasma and 243 s with NH₃ plasma. Again, the results prove that higher amount of nitrogen on the PET sample is favourable for higher uptake of UV-responsive microcapsules. Even short treatment with NH₃ plasma (i.e. sample 100sO₂ + 3sNH₃) improves the colour depth by 50%. It was reported [46] that the pre-treatment of cotton fabric with cationic agent increased the uptake of photochromic microcapsules onto fibres during dyeing process due to incorporation of cationic charged groups onto fabric surface. The producer of microcapsules Itofinish UV blue suggests the pre-treatment of fabrics with cationic agent to enable exhaustion of negatively charged microcapsules on the fabric. In our case the incorporation of cationic groups onto PET fabric surface was obtained by NH₃ MW plasma afterglow, which caused higher uptake of microcapsules with photochromic dye at pad-dry-cure process. Therefore, the uptake of UV-responsive microcapsules is governed by two factors, one is the hydrophilic nature of substrate i.e. increased hydrophilic nature of PET fabric (Table 2), and the other is the presence of cationic functional groups on the substrate i.e. incorporation of nitrogen rich groups onto PET fabric (Table 1).

4. Conclusions

The increased embedment of UV-responsive microcapsules on hydrophobic PET fabric was successfully achieved by treating fabric in microwave discharge afterglow of oxygen and ammonia, and combination of these gases. The uptake of microcapsules was highest on sample treated with O₂ plasma afterglow for 200 s and subsequently with NH₃ plasma afterglow for 243 s. This sample had an add-on almost 8-times higher than untreated sample, which consequently led to increased colour strength (K/S values), up to 75% improvement in colour depth and the colour difference between the untreated and plasma-treated sample with a value of 7. Higher uptake of microcapsules also led to a smaller decrease of air permeability. The reasons for the higher embedment of microcapsules on plasma treated PET fabric were changes of hydrophobic character of PET, which became hydrophilic after O₂ MW plasma afterglow treatment, and functionalisation with nitrogen-rich functional groups on the surface of NH₃ plasma afterglow treated fabric. Treating PET with O₂ MW afterglow enabled better reactivity of the substrate to bond the nitrogen-rich functional groups after NH₃ afterglow treatment. The results demonstrate the positive contribution of treating PET fabric with neutral oxygen atoms, hydrogen and NH_x radicals produced in plasma to achieve higher reactivity of the substrate and consequently higher uptake of UV-responsive microcapsules.

Acknowledgements

The research was financially supported by Slovenian research agency (programmes P2-0213 and P2-0082). ZLJP, N P and K.S. are grateful to projects III41011 and ON171037 of the MPNTR RS.

References

- [1] J.B. Kerr, V.E. Fioletov, Surface ultraviolet radiation, *Atmos. Ocean* 46 (2008) 159–184, <http://dx.doi.org/10.3137/ao.460108>.
- [2] R.D. Ley, Dose response for ultraviolet radiation A–induced focal melanocytic hyperplasia and nonmelanoma skin tumors in monodelphis domestica, *Photochem. Photobiol.* 73 (2001) 20–23.
- [3] S. Malinovic, D.T. Mihailovic, D. Kapor, Z. Mijatovic, I.D. Arsenic, NEOPLANTA: a short description of the first Serbian UV index model, *J. Appl. Meteorol. Climatol.* 45 (2006) 1171–1177, <http://dx.doi.org/10.1175/JAM2400.1>.
- [4] T. Rijavec, S. Bračko, Smart dyes for medical and other textiles, in: L. van Langehove (Ed.), *Smart Text. Med. Healthc. Mater. Syst. Appl.*, CRC press, Woodhead Publishing, Cambridge, 2007, pp. 123–149.
- [5] M. Kozicki, E. Sasiadek, Textile UV detector with 2,3,5-triphenyltetrazolium chloride as an active compound, *Radiat. Meas.* 46 (2011) 510–526, <http://dx.doi.org/10.1016/j.radmeas.2011.03.016>.
- [6] M. Kozicki, E. Sasiadek, I. Karbownik, W. Maniukiewicz, Doped polyacrylonitrile fibres as UV radiation sensors, *Sens. Actuators B Chem.* 213 (2015) 234–243, <http://dx.doi.org/10.1016/j.snb.2015.02.087>.
- [7] M. Aldib, R.M. Christie, Textile applications of photochromic dyes. Part 5: application of commercial photochromic dyes to polyester fabric by a solvent-based dyeing method, *Color. Technol.* 129 (2013) 131–143, <http://dx.doi.org/10.1111/cote.12008>.
- [8] T.L. Dawson, Changing colours: now you see them, now you don't, *Color. Technol.* 126 (2010) 177–188, <http://dx.doi.org/10.1111/j.1478-4408.2010.00247.x>.
- [9] M. Vikova, M. Vik, Colour shift photochromic pigments in colour space CIE L*a*b*, *Mol. Cryst. Liq. Cryst.* 431 (2005) 403–415, <http://dx.doi.org/10.1080/15421400590946947>.
- [10] Y. Zhou, Y. Yan, Y. Du, J. Chen, X. Hou, J. Meng, Preparation and application of melamine-formaldehyde photochromic microcapsules, *Sens. Actuators B Chem.* 188 (2013) 502–512, <http://dx.doi.org/10.1016/j.snb.2013.07.049>.
- [11] N. Vazquez-Mera, C. Roscini, J. Hernando, D. Ruiz-Molina, Liquid-filled capsules as fast responsive photochromic materials, *Adv. Opt. Mater.* 1 (2013) 631–636, <http://dx.doi.org/10.1002/adom.201300121>.
- [12] Polyesters and Polyamides, in: B.L. Deopura, R. Alagirusamy, M. Joshi, B. Gupta (Eds.), Woodhead Publishing, Boca Raton, 2008.
- [13] A. Al-Etaibi, H. Alnassar, M. El-Asasery, Dyeing of polyester with disperse dyes: Part 2. Synthesis and dyeing characteristics of some azo disperse dyes for polyester fabrics, *Molecules* 21 (2016) 855, <http://dx.doi.org/10.3390/molecules21070855>.
- [14] M. Muneer, S. Adeel, S. Ayub, M. Zuber, F. Ur-Rehman, M.I. Kanjal, M. Iqbal, M. Kamran, Dyeing behaviour of microwave assisted surface modified polyester fabric using Disperse orange 25: improvement in colour strength and fastness properties, *Oxid. Commun.* 39 (2016) 1430–1439.
- [15] B. Golja, B. Šumiga, B. Boh, J. Medved, T. Pušič, P.F. Tavčer, Application of flame retardant microcapsules to polyester and cotton fabrics, *Mater. Tehnol.* 48 (2014) 105–111.
- [16] M. Gorenšek, M. Gorjanc, V. Bukošek, J. Kovač, P. Jovančič, D. Mihailović, Functionalization of PET fabrics by corona and nano silver, *Text. Res. J.* 80 (2010) 253–262, <http://dx.doi.org/10.1177/0040517509105275>.
- [17] I.C. Gouveia, L.C. Antunes, A.P. Gomes, Low-pressure plasma treatment for hydrophilization of poly(ethylene terephthalate) fabrics, *J. Text. Inst.* 102 (2011) 203–213, <http://dx.doi.org/10.1080/00405001003616777>.
- [18] M. Gorenšek, M. Gorjanc, V. Bukošek, J. Kovač, Z. Petrovič, N. Puač, Functionalization of polyester fabric by Ar/N₂ plasma and silver, *Text. Res. J.* 80 (2010) 1633–1642, <http://dx.doi.org/10.1177/0040517510365951>.
- [19] V. Takke, N. Behary, A. Perwuelz, C. Campagne, Surface and adhesion properties of poly(ethylene glycol) on polyester(polyethylene terephthalate) fabric surface: effect of air-atmospheric plasma treatment, *J. Appl. Polym. Sci.* 122 (2011) 2621–2629, <http://dx.doi.org/10.1002/app.34403>.
- [20] M.Ö. Öteyaka, P. Chevallier, S. Turgeon, L. Robitaille, G. Laroche, Low pressure radio frequency ammonia plasma surface modification on poly(ethylene terephthalate) films and fibers: effect of the polymer forming process, *Plasma Chem. Plasma Process.* 32 (2012) 17–33, <http://dx.doi.org/10.1007/s11090-011-9330-3>.
- [21] M. Gorjanc, M. Mozetič, Modification of Fibrous Polymers by Gaseous Plasma: Principles, Techniques and Applications, LAP Lambert Academic Publishing, Saarbrücken, 2014.
- [22] C. López-Santos, F. Yubero, J. Cotrino, A.R. González-Elipse, Surface functionalization, oxygen depth profiles, and wetting behavior of PET treated with different nitrogen plasmas, *ACS Appl. Mater. Interfaces* 2 (2010) 980–990, <http://dx.doi.org/10.1021/am100052w>.
- [23] S. Babaei, P.L. Girard-Lauriault, Tuning the surface properties of oxygen-rich and nitrogen-rich plasma polymers: functional groups and surface charge, *Plasma Chem. Plasma Process.* 36 (2016) 651–666, <http://dx.doi.org/10.1007/s11090-015-9682-1>.
- [24] T. Tkavc, A. Vesel, E.H. Acero, L.F. Zemljici, Comparison of oxygen plasma and cutinase effect on polyethylene terephthalate surface, *J. Appl. Polym. Sci.* 128 (2013) 3570–3575, <http://dx.doi.org/10.1002/app.38526>.
- [25] I. Junkar, M. Modic, M. Mozetič, Modification of PET surface properties using extremely non-equilibrium oxygen plasma, *Open Chem.* 13 (2015) 490–496, <http://dx.doi.org/10.1515/chem-2015-0061>.
- [26] J. Lv, Q. Zhou, T. Zhi, D. Gao, C. Wang, Environmentally friendly surface modification of polyethylene terephthalate (PET) fabric by low-temperature oxygen plasma and carboxymethyl chitosan, *J. Clean. Prod.* 118 (2016) 187–196, <http://dx.doi.org/10.1016/j.jclepro.2016.01.058>.
- [27] M.J. Farrell, M.A. Ankeny, P.J. Hauser, Prediction of recipes for cotton cationisation and reactive dyeing to shade match conventionally dyed cotton, *Color. Technol.* 130 (2014) 363–367, <http://dx.doi.org/10.1111/cote.12101>.
- [28] F.R. Oliveira, M. Fernandes, N. Carneiro, A. Pedro Souto, Functionalization of wool fabric with phase-change materials microcapsules after plasma surface

- modification, *J. Appl. Polym. Sci.* 128 (2013) 2638–2647, <http://dx.doi.org/10.1002/app.38325>.
- [29] T. Salem, D. Pleul, M. Nitschke, M. Müller, F. Simon, Different plasma-based strategies to improve the interaction of anionic dyes with polyester fabrics surface, *Appl. Surf. Sci.* 264 (2013) 286–296, <http://dx.doi.org/10.1016/j.apsusc.2012.10.014>.
- [30] Q. Zheng, J. Huang, S. Cao, H. Gao, A flexible ultraviolet photodetector based on single crystalline MoO₃ nanosheets, *J. Mater. Chem. C* 3 (2015) 7469–7475, <http://dx.doi.org/10.1039/C5TC00850F>.
- [31] T.K. Markkula, J.A. Hunt, F.R. Pu, R.L. Williams, Surface chemical derivatization of plasma-treated PET and PTFE, *Surf. Interface Anal.* 34 (2002) 583–587, <http://dx.doi.org/10.1002/sia.1365>.
- [32] J. Casimiro, B. Lepoittevin, C. Boisse-Laporte, M.G. Barthés-Labrousse, P. Jegou, F. Brisset, P. Roger, Introduction of primary amino groups on poly(ethylene terephthalate) surfaces by ammonia and a mix of nitrogen and hydrogen plasma, *Plasma Chem. Plasma Process.* 32 (2012) 305–323, <http://dx.doi.org/10.1007/s11090-011-9345-9>.
- [33] M. Kolar, M. Mozetič, K. Stana-Kleinschek, M. Fröhlich, B. Turk, A. Vesel, Covalent binding of heparin to functionalized PET materials for improved haemocompatibility, *Materials (Basel)* 8 (2015) 1526–1544, <http://dx.doi.org/10.3390/ma8041526>.
- [34] A. Vesel, M. Mozetič, Low-pressure plasma-assisted polymer surface modifications, in: J. Izdebska, S. Thomas (Eds.), *Print. Polym. Fundam. Appl.*, Elsevier, Amsterdam, 2016, pp. 101–121.
- [35] M. Mozetič, A. Vesel, V. Monna, A. Ricard, H density in a hydrogen plasma post-glow reactor, *User Model. User-Adapt. Interact.* 71 (2003) 201–205, [http://dx.doi.org/10.1016/S0042-207X\(02\)00737-6](http://dx.doi.org/10.1016/S0042-207X(02)00737-6).
- [36] N. Recek, A. Vesel, Surface modification of polymer polyethylene terephthalate with plasmas created in different gases, *Mater. Technol.* 48 (2014) 893–897.
- [37] Z. Omerogullari, D. Kut, Application of low-frequency oxygen plasma treatment to polyester fabric to reduce the amount of flame retardant agent, *Text. Res. J.* 82 (2012) 613–621, <http://dx.doi.org/10.1177/0040517511420758>.
- [38] H. Dave, L. Ledwaini, N. Chandwani, K. Puravi, B. Desai, S.K. Nema, Surface modification of polyester fabric by non-thermal plasma treatment and its effect on coloration using natural dye surface modification of polyester fabric by non-thermal plasma treatment and its effect on, *J. Polym. Mater.* 30 (2013) 291–304.
- [39] P. Mazeyer, E. Izadyar, Influence of atmospheric-air plasma on the coating of a nonionic lubricating agent on polyester fiber, *Radiat. Eff. Defects Solids* 166 (2011) 408–416, <http://dx.doi.org/10.1080/10420150.2011.553230>.
- [40] I. Novák, I. Chodák, J.Á.N. Sedláčik, J. Prachár, Pre-treatment of polyester-based veneers, *Ann. Warsaw Univ. Life Sci. For. Wood Technol.* 92 (2015) 312–316.
- [41] M.M. Kamel, M.M. El Zawahry, H. Helmy, M.A. Eid, Improvements in the dyeability of polyester fabrics by atmospheric pressure oxygen plasma treatment, *J. Text. Inst.* 102 (2011) 220–231, <http://dx.doi.org/10.1080/00405001003672366>.
- [42] L.J. Gerenser, J.M. Grace, G. Apai, P.M. Thompson, Surface chemistry of nitrogen plasma-treated poly(ethylene-2,6-naphthalate): XPS HREELS and static SIMS analysis, *Surf. Interface Anal.* 29 (2000) 12–22, [http://dx.doi.org/10.1002/\(SICI\)1096-9918\(200001\)29:1<12:AID-SIA687>3.0.CO;2-7](http://dx.doi.org/10.1002/(SICI)1096-9918(200001)29:1<12:AID-SIA687>3.0.CO;2-7).
- [43] M.I. Guignard, C. Campagne, S. Giraud, M. Brebu, N. Vrinceanu, L.I. Cioca, Functionalization of a bamboo knitted fabric using air plasma treatment for the improvement of microcapsules embedding, *J. Text. Inst.* 106 (2015) 119–132, <http://dx.doi.org/10.1080/00405000.2014.942115>.
- [44] M.A. Chowdhury, M. Joshi, B.S. Butola, Photochromic and thermochromic colorants in textile applications, *J. Eng. Fibres Fabr.* 9 (2014) 107–123.
- [45] A. Berger-Schunn, *Practical Color Measurement*, John Wiley & Sons, Inc, New York, 1994.
- [46] M. Kamata, S. Osamu, S. Suefuku, S. Ohtsu-shi, T. Maeda, Dyeing method and dyed product, EP0480162 (A1) – 1992-04-15 (1991).

Article

Application of Fragrance Microcapsules onto Cotton Fabric after Treatment with Oxygen and Nitrogen Plasma

Mateja Kert¹, Petra Forte Tavčer¹, Aleš Hladnik¹ , Kosta Spasić², Nevena Puač² , Zoran Lj. Petrović^{3,4} and Marija Gorjanc^{1,*} 

¹ Faculty of Natural Sciences and Engineering, University of Ljubljana, Aškerčeva 12, SI-1000 Ljubljana, Slovenia; mateja.kert@ntf.uni-lj.si (M.K.); petra.forte@ntf.uni-lj.si (P.F.T.); ales.hladnik@ntf.uni-lj.si (A.H.)

² Institute of Physics of Belgrade, University of Belgrade, Pregrevica 118, 11080 Belgrade, Serbia; kosta.spasic@ipb.ac.rs (K.S.); nevena@ipb.ac.rs (N.P.)

³ Serbian Academy of Sciences and Arts, Knez Mihajlova 35, 11000 Belgrade, Serbia; zoran@ipb.ac.rs or z.petrovic@ulster.ac.uk

⁴ Nanotechnology and Integrated Bio-Engineering Centre (NIBEC), School of Engineering, University of Ulster, Newtownabbey, Antrim BT37 0QB, UK

* Correspondence: marija.gorjanc@ntf.uni-lj.si

Abstract: Cotton fabric was exposed to low-pressure capacitively coupled plasma to enhance the adsorption and adhesion of fragrance microcapsules (FCM). Two plasma-forming gases, namely oxygen (O₂) and nitrogen (N₂), were investigated. The untreated and plasma-treated samples were investigated for their morphological changes by scanning electron microscopy (SEM), mechanical properties (breaking force, elongation, and flexural rigidity), and wicking properties. The cotton samples were functionalized with FCM and the effect of plasma pretreatment on the adsorption and adhesion of FCM was evaluated using SEM, air permeability, fragrance intensity of unwashed and washed cotton fabrics, and Fourier transform infrared spectroscopy (FTIR). The results show that the plasma containing either of the two gases increased the wicking of the cotton fabric and that the O₂ plasma caused a slight etching of the fibers, which increased the tensile strength of the cotton fabric. Both plasma gases caused changes that allowed higher adsorption of FCM. However, the adhesion of FCM was higher on the cotton treated with N₂ plasma, as evidenced by a strong fragrance of the functionalized fabric after repeated washing.

Keywords: fragrance microcapsules; cotton; oxygen plasma; nitrogen plasma



Citation: Kert, M.; Forte Tavčer, P.; Hladnik, A.; Spasić, K.; Puač, N.; Petrović, Z.L.; Gorjanc, M. Application of Fragrance Microcapsules onto Cotton Fabric after Treatment with Oxygen and Nitrogen Plasma. *Coatings* **2021**, *11*, 1181. <https://doi.org/10.3390/coatings11101181>

Academic Editor: Fabien Salaün

Received: 25 August 2021

Accepted: 24 September 2021

Published: 28 September 2021

Publisher's Note: MDPI stays neutral with regard to jurisdictional claims in published maps and institutional affiliations.



Copyright: © 2021 by the authors. Licensee MDPI, Basel, Switzerland. This article is an open access article distributed under the terms and conditions of the Creative Commons Attribution (CC BY) license (<https://creativecommons.org/licenses/by/4.0/>).

1. Introduction

Textiles with embedded fragrance microcapsules are a class of cosmetotextiles and are called aromatherapeutic textiles [1]. Such textiles provide the scent of essential oils derived from plant-based raw materials, which could boost the emotional and physical scene of the body [2]. Fragrance microcapsules consist of essential oils or fragrant compounds in the core and polymers as a wall material. The controlled release of the essential oil from the polymer layer of the microcapsule relies on four mechanisms: mechanical stimuli (during the application of mechanical force in processing), chemical stimuli (the core material slowly dissolves in the shell membrane), thermal stimuli (heat), and diffusion [3]. Cotton is a textile material found in many practical applications, such as fibrous porous media, clothing, household, and health care textiles and could be a promising textile substrate for application of fragrance microcapsules for aromatherapeutic textiles [1–4]. The embedding of fragrant microcapsules on textiles imparts new properties and added value to products, with multiple applications such as clothing, decorative textiles, and non-implantable medical textiles [5]. Application of microcapsules to textiles can be done by padding, coating, immersion, spraying, and printing [6–10]. The results of research reports comparing different methods of applying fragrant microcapsules to textiles (i.e., printing, padding,

exhaustion) show that the padding technique is more suitable than others because the yield is higher, fewer chemicals are required, and it can be done at room temperature [6,9,10]. A major problem associated with the application of microcapsules on textiles is the loss of textile functionality after a few wash cycles, even if binders are used in the application. Factors that influence the increase in wash resistance are the use of acrylic binders, proper curing conditions, and plasma pretreatment [11–19]. The advantage of plasma pretreatment is that it is a dry process that enables an introduction of functional groups on fibers and polymers in an environmentally friendly manner. During plasma treatment, the surface morphology of the treated samples is changed without affecting their bulk properties. Combination of changed morphology and activated surface allows increased embedment of nanoparticles, microcapsules, dyes, and other coatings [20–25]. The plasma used for the functionalization of textile surfaces has to be non-equilibrium, which means that electrons have to have few orders of magnitude higher temperature than ions or neutral species. In these kind of discharges, heavy particles (ions and neutrals) usually have energies that correspond to room temperature. Additionally, plasma needs to produce ample radicals and other active species that would open bonds on the substrate surface and make it possible to produce binding sites for the microcapsules. All these requirements can be accomplished by using a low-pressure plasma that would properly activate the surface, but it would also make it possible to treat materials that may be strongly affected or even destroyed by high temperatures [26–34]. Previously published research on improving the adsorption or adhesion of microcapsules using plasma has mainly focused on atmospheric dielectric barrier discharge (DBD) air plasma on cotton/polyester, wool and natural cork [13,15,18], atmospheric air corona plasma on bamboo [16], and low-pressure oxygen plasma on polydimethylsiloxane [17]. The improved adsorption of crosslinkers and phase change materials on plasma-treated materials was attributed to the increased wettability and surface energy, either due to the higher plasma dosage (in $W \cdot \text{min}/\text{m}^2$) or the power of the plasma reactor (in W). No attempts have been made to investigate different gases for the generation of plasma discharge, except in our previously published work, where polyethylene terephthalate was modified with oxygen and ammonia plasma to improve the embedding of UV-responsive microcapsules [32].

Since the important factor in plasma pretreatment for improved embedding of coatings is also related to the proper choice of working gas, in this study, we focused on the treatment of cotton fabric with oxygen and nitrogen plasma discharges to evaluate which gas is more suitable for functionalizing cotton fabric and enhancing the binding of fragrance microcapsules.

2. Materials and Methods

2.1. Materials

A chemically bleached 100% cotton fabric from the manufacturer Tekstina d.d., Ajdovščina, Slovenia, was used for the study (plain weave, mass $125 \text{ g}/\text{m}^2$, warp density 50 threads/cm, weft density 30 threads/cm). Suspension of 2–8 μm sized microcapsules with a pressure-sensitive melamine-formaldehyde wall and a liquid core were prepared at Aero d.d., Celje, Slovenia, by in situ polymerization of melamine-formaldehyde prepolymers [35]. The mass fraction of cores in all microcapsules was 75% and the mass fraction of walls was 25%. The mass fraction of microcapsules in suspensions was 32%. The core of the microcapsules contained strawberry essential oil in isopropyl myristate as solvent (25% essential oil and 75% isopropyl myristate). Thermal and mechanical properties of these microcapsules are reported in the literature [36,37]. The binder used was acrylic (Itobinder AG, MagnaColours, Barnsley, UK).

2.2. Treatment of Cotton in Plasma

The treatments of cotton samples were carried out in a Capacitively Coupled Plasma (CCP) system [38,39], which is shown in Figure 1. The discharge chamber is made of stainless steel and is cylindrical in shape (46 cm long with diameter of 37 cm). The powered

electrode is an axially placed aluminum rod (diameter 14 mm), while the chamber walls serve as the grounded electrode. The sample holder is located at the bottom of the chamber and is also electrically grounded. Power is supplied by a commercially available power supply unit Dressler Cesar 1310 (Advanced Energy, Campbell, CA, USA) at 13.56 MHz in combination with an automatic matching network Variomatch (Advanced Energy, Campbell, CA, USA). This device allows precise control and tuning of both transmitted and reflected power. Treatments were performed at 100 W, while the reflected power was maintained at 0 W. A mechanical pump (DUO 65, Pfeiffer Vacuum GmbH, Asslar, Germany) was used to generate the vacuum, while pressure control was achieved by regulating the influx gasses with a mass flow controller. Namely, we used the two working gases oxygen (O_2) and nitrogen (N_2) at a constant pressure of 200 mTorr. To keep this pressure constant, the flow of oxygen (for O_2 plasma) and nitrogen (for N_2 plasma) was 85 sccm. The treatment time for all samples was 5 min.

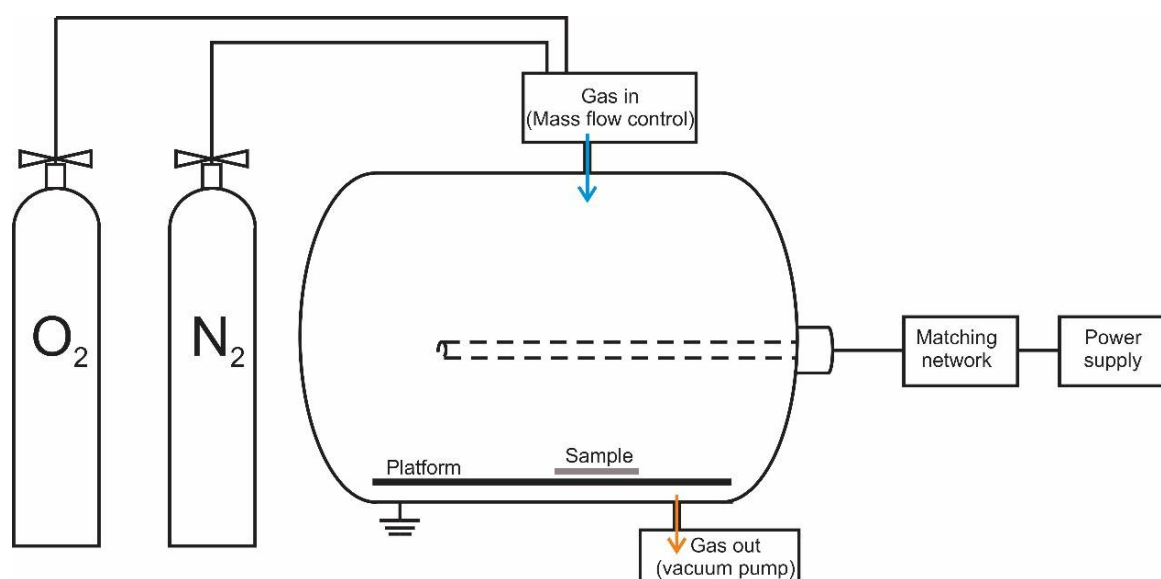

Figure 1. Asymmetrical CCP system used for treatments of cotton samples. The power of the RF power supply was 100 W, the working gases were O_2 and N_2 , the pressure 200 mTorr and the treatment time 5 min. The platform positioned at the bottom of the chamber is grounded.

2.3. Application of Microcapsules

The untreated and plasma treated cotton fabrics were coated with fragrance microcapsules using the pad-dry-cure method. The cotton fabrics were padded with prepared padding bath containing 50 g/L microcapsule suspension and 50 g/L Itobinder AG (MagnaColours, Barnsley, UK) at room temperature using 80% wet pick up. After padding, the fabrics were dried at 100 °C for 3 min and cured at 150 °C for 5 min.

2.4. Scanning Electron Microscopy

The morphology of the cotton fabrics was recorded using a scanning electron microscope (SEM; JEOL SEM type JSM-6060LV, Jeol, Tokyo, Japan) [32]. Before scanning, all samples were coated with a thin layer of gold. The electron beam voltage used was 10 kV, the electric current was 85 μ A and the spot size (diameter of the electron probe) was 30.

2.5. Tensile Property of the Fabrics

The breaking force, expressed in N (newton), and the elongation, expressed in %, of the untreated and the plasma treated fabrics was analyzed according to the standard SIST EN ISO 13934-1:2013 [40] using an Instron 6022 dynamometer (Instron, Norwood, MA, USA) [41]. The 150 mm \times 20 mm samples were analyzed in the warp direction with a

preload of 1 N and a speed of 100 mm/min. Ten samples were analyzed for each treatment and the average value and standard deviation were calculated.

2.6. Fabrics Stiffness

The stiffness of the untreated and plasma-treated fabric was evaluated as a flexural rigidity according to the standard ASTM D1388—Option A: Cantilever Test [42], employing the principle of cantilever bending of the fabric under its own mass [43]. Twelve test specimens of each treatment were cut to size 150 mm × 25 mm (longer side in warp direction) and placed on a smooth, low-friction horizontal platform inclined at 41.5°. A weighted sled was placed over the specimen and moved forward at a constant speed. When the specimen bent and touched the slope of the platform, the length of the overhang was measured in centimeters. Flexural rigidity (G) was calculated from Equation (1):

$$G = W \times \left(\frac{O}{2}\right)^3 \quad (1)$$

where W is mass per unit area (mg/cm^2), O is the length of overhang (cm).

The average and standard deviation of twelve measurements for each treatment were calculated.

2.7. Absorptiveness of Fabrics

The untreated and plasma-treated cotton fabrics were tested for their absorbency using the capillary rise method according to the standard DIN 53924 [44]. Four samples of size of 250 mm × 30 mm were prepared. Each sample was hung vertically and aligned parallel to the ruler with millimeter divisions. The lower end of the sample was immersed 10 mm deep into the lightly colored distilled water. After 30, 60, and 300 s, the height of the wicking above the water surface was measured. The results are given as the mean and standard deviation of the four measurements.

2.8. Fragrance Evaluation

The method for fragrance evaluation was based on the Lewis procedure [10–12] with a panel of thirty judges. The samples were first hung on a clothesline in a room for 1 h to stabilize the evaporation of the fragrance. Then the samples were taken to a judge in an evaluation room. The cotton fabric coated with microcapsules was placed on a flat, hard plate on a table. The judges used their fingernails to scratch an “X” into the fabric to break some of the microcapsules and smell the sample. They then noted a “yes” for the presence of a strong, medium, or weak scent or a “no” for the absence of any scent. No judge tested for more than 15 min. If a scent was judged to be present by a majority of the judges, the condition was recorded as “passed.” Judges were required to evaluate samples from three treatments: untreated, O_2 and N_2 plasma treated samples coated with fragrance microcapsules, before and after repeated washing. Results are presented as the number of responses from judges who scored each treatment.

2.9. Air Permeability of the Fabrics

The air permeability of cotton samples coated with microcapsules before and after repeated washing cycles was determined according to the standard SIST EN ISO 9237:1999 [45] using the AirTronic 3240B air permeability tester (Mesdan, Raffa, Italy) at a pressure drop of 1000 Pa. The air permeability, expressed in mm/s , was calculated according to the following Equation (2):

$$R = \frac{q_v}{A} \times 167 \quad (2)$$

where q_v is the arithmetic mean of the air flow rate in L/min , A is the area of the fabric tested in cm^2 , and 167 is the conversion factor from L/min to mm/s .

The results are given as the mean and standard deviation of the four measurements.

2.10. Fastness of the Coated Fabric to Washing

Washing of microcapsule-coated cotton fabrics was performed in laboratory washing apparatus Launder-Ometer (SDL Atlas, Rock Hill, SC, USA), using 4 g/L of standard detergent European Colorfastness Establishment (ECE) for 45 min at 40 °C according to the standard SIST EN ISO 105-C06:2012 [46]. The number of washing cycles was 1, 5, and 10. To simulate five domestic washings, 10 stainless steel balls were added to each wash bath. After washing, the samples were rinsed twice with distilled water and then air dried at room temperature.

2.11. Fourier-Transform Infrared Spectroscopy (FTIR)

The ATR-FTIR (attenuated total reflectance—Fourier transform infrared spectroscopy) spectra of the untreated and plasma treated samples were recorded using an FTIR spectrophotometer (Bruker IFS 66/S, Billerica, MA, USA). The spectra were recorded from samples pressed firmly against a cylindrical Ge crystal. The resolution of the instrument was 4 cm⁻¹ for 64 scans and the spectra were obtained over the range 4000–600 cm⁻¹. To better interpret the spectra, a principal component analysis (PCA) was performed on the data obtained. PCA [47] is a commonly used chemometric technique [48,49] that linearly and orthogonally transforms the original data into a new coordinate system of principal components (PCs). The number of extracted PCs is equal to the number of original variables, but in general the first few—two or three—PCs are already responsible for most of the variability in the data. Their visualization allows to detect hidden patterns and trends in the data. PCA was performed after baseline correction of each spectrum run using MATLAB[®] (ver 2014b, MathWorks, Inc., Natick, MA, USA).

3. Results and Discussion

Increasing the adsorption and adhesion of microcapsules on cotton fabric enables wash durability of the coating and thus the development of the value-added textile products. To achieve this, the use of environmentally friendly technologies, such as plasma treatment, plays a crucial role. Cotton fabrics were treated with oxygen (O₂) and nitrogen (N₂) in capacitively coupled plasma to evaluate which working gas is more suitable for modifying cotton to achieve increased uptake (adsorption) of the fragrance microcapsules and ensure good adhesion to the fibers. Firstly, the properties of the untreated and plasma-treated fabrics without microcapsules were evaluated to analyze their surface morphology, breaking strength and elongation, flexural rigidity, and wicking. The surface morphology of the fibers changes only after treating the fabric with O₂ (Figure 2b), but not after treating the fabric with N₂ plasma (Figure 2c). The O₂ plasma-treated sample (Figure 2b) exhibits visible cellulose fibrils extending out of the fiber surface, similar to those observed after treatment with inductively coupled water vapor plasma [22] and air corona plasma [50]. The reason of changed topography is the etching effect of O₂ plasma treatment. In oxygen-rich plasma, the reactive species cause chemical erosion (atoms) and physical erosion (ions) [51,52]. Flynn et al. [51] and Vesel et al. [52] also reported that nitrogen-rich plasma (i.e., nitrogen or ammonia gases) does not have a significant effect on surface roughness due to the difference in etch rate compared to oxygen-rich plasma (i.e., water vapor, air, or oxygen gases), but it does on the surface functionalization with nitrogen-rich groups. Similar results were found by Pranslip et al. [53] who treated cotton fabric with oxygen, nitrogen, and hexafluoride (SF₆) plasma to improve ink absorption. While O₂ and SF₆ plasma provided a stronger impulse to increase surface roughness, the N₂ plasma had only a very weak etching effect even after 20 min of plasma treatment.

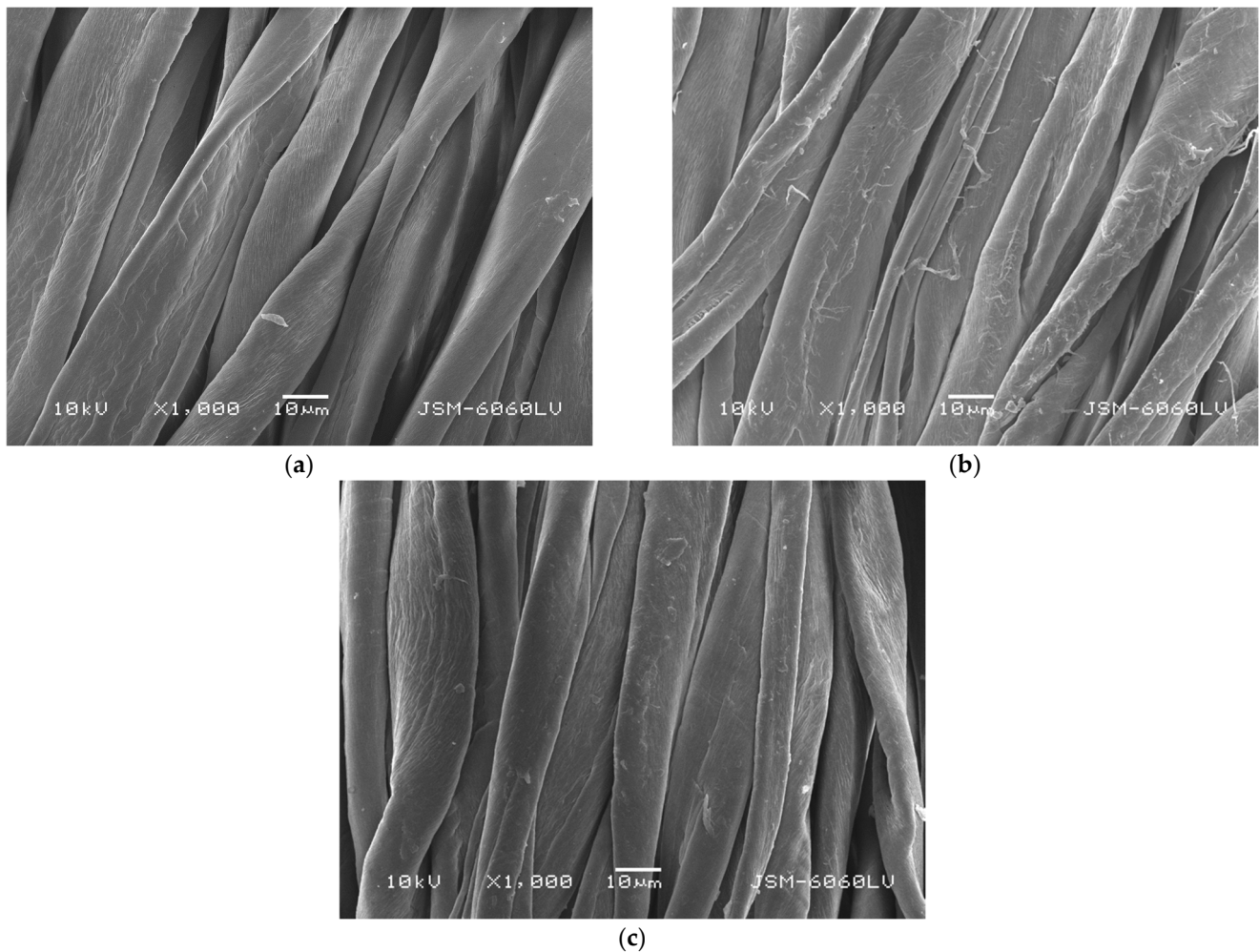

Figure 2. SEM images of (a) untreated, (b) O₂ plasma-treated, and (c) N₂ plasma-treated samples of cotton fabric.

The morphological changes caused by etching the surface of the cotton fibers could lead to a deterioration of the mechanical properties of the fabrics. However, the results presented in Table 1 show that breaking strength of the cotton fabric increases after plasma treatment, whilst the breaking elongation also increases but to a much lesser extent. The effect is more pronounced for the samples treated with O₂ plasma. An interesting effect observed on plasma-treated fabrics was lower flexural rigidity, i.e., the fabrics were less stiff after plasma treatment. The explanation for such an effect could be weight loss due to the etching effect of plasma [53]. However, in our case, the etching effect of O₂ plasma was low (Figure 2b), and no etching effect was observed on the sample treated with N₂ plasma (Figure 2c), which had the lowest value for flexural rigidity.

Table 1. Breaking strength (N) and elongation (mm) and flexural rigidity (mg·cm) of untreated and plasma-treated samples.

Sample	Breaking Force (N)	Breaking Elongation (%)	Flexural Rigidity (mg·cm)
Untreated	357.7 ± 13.0	14.9 ± 1.4	266.0 ± 18.6
O ₂ plasma	403.6 ± 9.1	16.4 ± 0.1	223.0 ± 3.7
N ₂ plasma	368.1 ± 26.3	15.7 ± 0.7	196.0 ± 9.1

Figure 3 and Table 2 show the wicking results of untreated and plasma treated samples. The wicking of cotton increases after treatment with plasma, regardless of the working gas

used. The differences in wicking height between untreated and plasma treated samples are already evident in the wicking measured after 30 s, as it increases from 33.5 ± 0.12 mm for the untreated sample to 38.5 ± 0.07 mm for the O₂ plasma treated sample and to 38.0 ± 0.07 mm for the N₂ plasma treated sample. The higher absorptivity of the plasma treated cotton samples becomes more evident after 300 s of measurement, where the difference between the heights of the capillary rise of the untreated and plasma treated cotton is 9 mm. Since the wicking of a substrate is directly related to the hydrophilicity of the substrate, it is clear from the results that both plasma treatments, regardless of the gas used (O₂ or N₂), increase the ability of the cotton to absorb water.

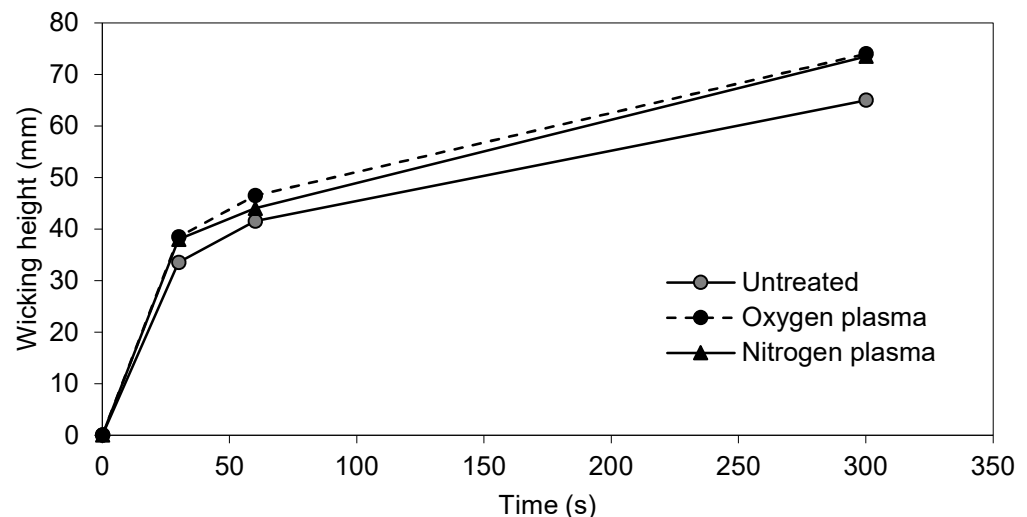

Figure 3. Wicking height (mm) of untreated and plasma treated samples after 30, 60, and 300 s.

Table 2. Wicking height (mm) of untreated and plasma-treated cotton samples measured after 30, 60, and 300 s.

Sample	Wicking Height (mm)		
	30 s	60 s	300 s
Untreated	33.5 ± 0.12	41.5 ± 0.13	65.0 ± 0.11
O ₂ plasma	38.5 ± 0.07	46.5 ± 0.12	74.0 ± 0.07
N ₂ plasma	38.0 ± 0.07	44.0 ± 0.11	73.5 ± 0.07

The untreated, O₂ plasma treated and N₂ plasma-treated cotton fabrics were coated with fragrance microcapsules (FCM). The effect of plasma on adsorption and adhesion of microcapsules was monitored by SEM, air permeability, and fragrance intensity after repeated washing. The morphology of the cotton samples coated with microcapsules is shown in Figure 4. The difference between the untreated and plasma treated samples is obvious. Both gases used for cotton treatment caused changes that allowed higher adsorption of FCM (Figure 4b,c). In addition, the incorporation of positively charged functional groups on the fabric surface, which was achieved by the N₂ plasma treatment, could increase the adsorption of the negatively charged acrylic binder due to electrostatic attractive interactions, which could be reflected in a higher amount of microcapsules adsorbed on the cotton fabric. The increased adsorption of microcapsules on N₂ plasma-treated fabric is evident from Figure 4c.

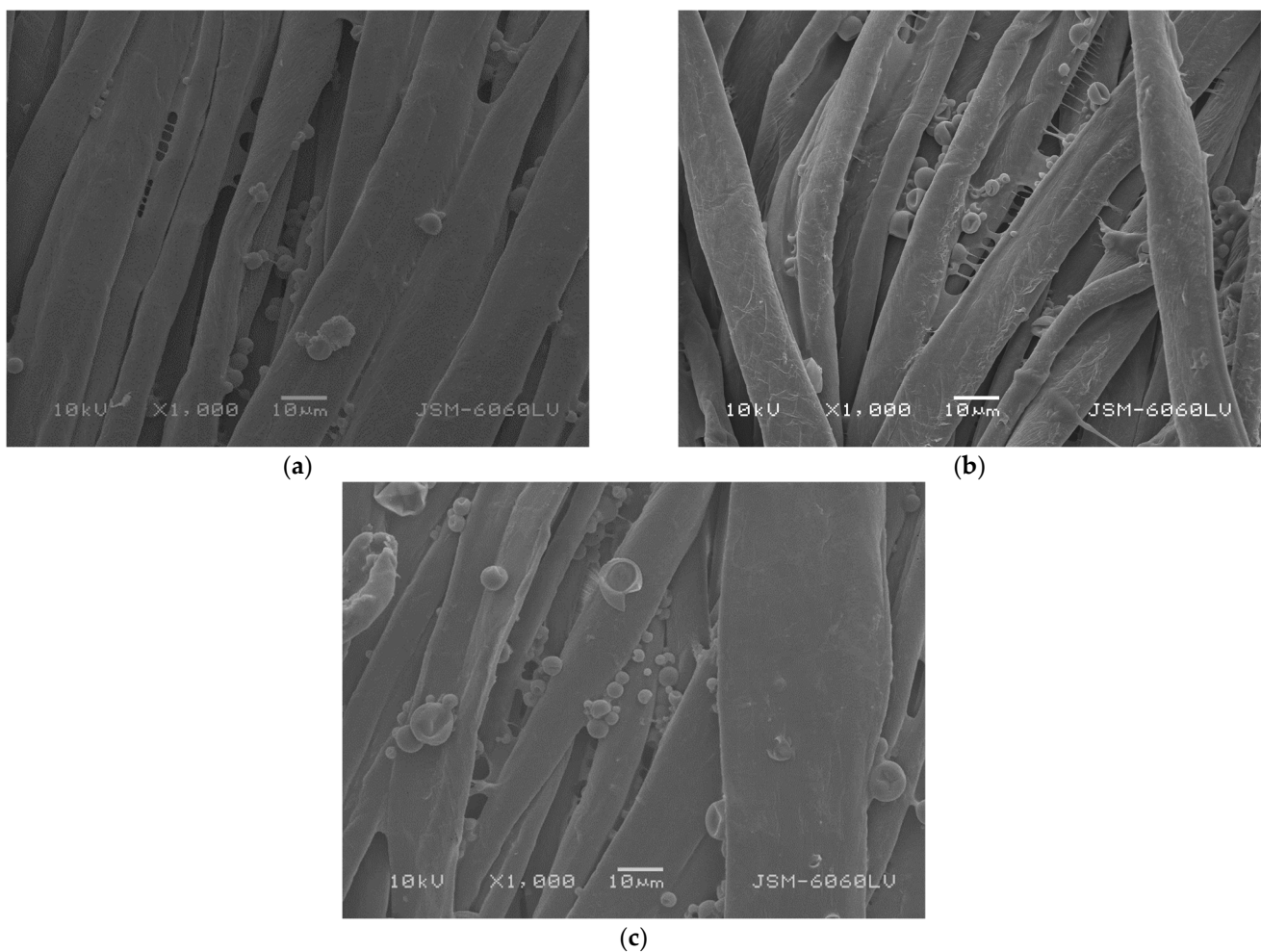

Figure 4. SEM images of (a) untreated, (b) O₂ plasma-treated, and (c) N₂ plasma-treated samples of cotton fabric impregnated with fragrance microcapsules.

The adsorption and adhesion of FCM on cotton fabric was evaluated measuring the air permeability of the fabric. The results presented in Figure 5 and Table 3 show that untreated and FCM-coated fabric is more air permeable than plasma-treated and FCM-coated fabrics. The lowest air permeability was found for the N₂ plasma-treated and FCM-coated sample (435.9 ± 8.5 mm/s), and the highest for the untreated and FCM-coated sample (457.2 ± 12.3 mm/s) (Table 3). The decrease of the air permeability is attributed to the binder layer that forms during the curing process and closes the voids between the fibers and consequently between warp and weft yarns of the fabric. It must be emphasized that not only binder layer, but also microcapsules themselves may contribute to lower air permeability. Since the lowest air permeability is obtained for the N₂ plasma treated and FCM-coated fabric, this indicates that this sample contains the highest amount of FCM. After repeated washing (i.e., 1, 5, and 10), the air permeability gradually increases for all samples as the binder layer is slowly removed, thus removing the microcapsules that were trapped in the binding layer. The removal of the FCM and binding layer was also confirmed by SEM (Figure 6). After the tenth wash, the least amount of FCM is visible on the surface of untreated and FCM-coated sample (Figure 6a). The voids between the fibers are almost completely free of the binder layer. The sample treated with O₂ plasma and coated with FCM has visible few smaller microcapsules on the surface after the tenth wash (Figure 6b). Here the binder layer between the fibers is more pronounced compared to the untreated and FCM-coated sample (Figure 6a). Also, the etching effect of the O₂ plasma is still visible as the fibrils protrude from the fibers surface (Figure 6b). The N₂ plasma-treated and FCM-coated sample has visibly the highest amount of microcapsules on the surface

after the tenth wash of all samples (Figure 6c). Many different size microcapsules are still attached to the fiber surface and are accompanied by the binder layer on and between the fibers. The removal of microcapsules and binder layer was attributed to mechanical action and abrasion between the stainless-steel balls and the sample during washing process. Since air permeability is lowest for the N₂ plasma-treated and FCM-coated sample, this indicates good wash resistance due to the higher adhesion of the microcapsules and binder layer compared to the untreated or O₂ plasma-treated sample. This observation is also in good agreement with the results reported in the literature. The adsorption and adhesion of various substances, e.g., silica [54], ink [55], copper [56], or even human monocytes [57] on polypropylene was enhanced after plasma treatment, and it was found that the adhesion was higher for N₂ plasma than for O₂ plasma-treated polymer. This is interesting as it is well documented that higher adhesion between materials is achieved by high surface roughness due to mechanical interlocking. From our results and reports in the literature, it can be concluded that nitrogen-rich functional groups (grafted onto the polymer surface) serve as binding sites for adsorption and electrostatic interactions for microcapsule adhesion.

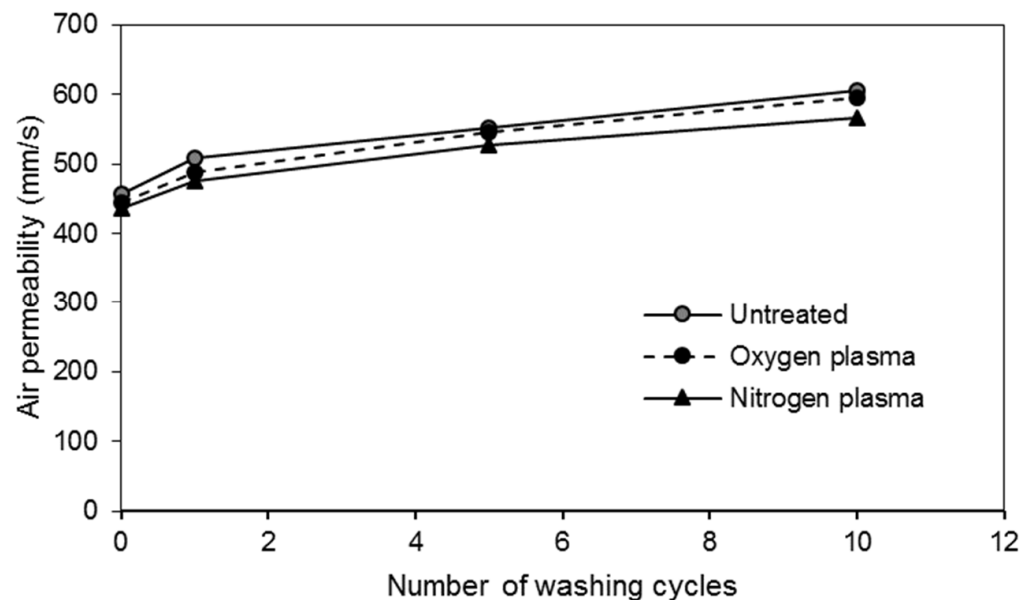

Figure 5. Air permeability (mm/s) of untreated and plasma-treated microcapsule-coated cotton fabrics before (zero number of washing) and after washing (one, five, and ten numbers of washing).

Table 3. Air permeability (mm/s) of untreated and plasma-treated microcapsule-coated cotton samples before (0 w) and after washing (1 w, 5 w, and 10 w).

Sample	Air Permeability (mm/s)			
	0 w	1 w	5 w	10 w
Untreated + FCM	457.2 ± 12.3	508.9 ± 13.1	552.4 ± 10.6	605.8 ± 5.1
O ₂ plasma + FCM	444.2 ± 10.6	488.9 ± 12.5	545.7 ± 3.1	595.5 ± 6.12
N ₂ plasma + FCM	435.9 ± 8.5	475.5 ± 9.5	526.9 ± 2.23	566.0 ± 1.4

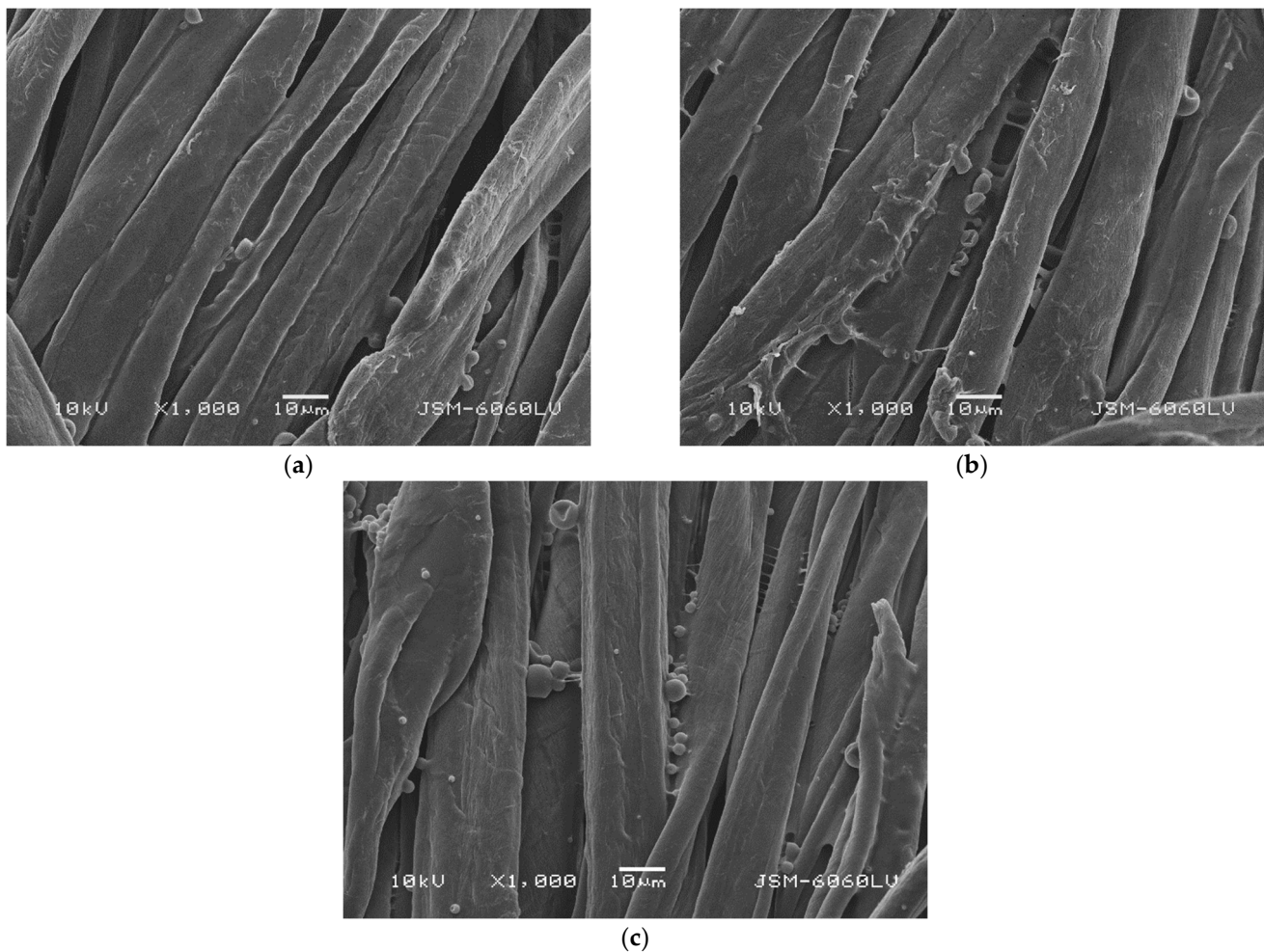

Figure 6. SEM images of (a) untreated and FCM-coated sample, (b) O₂ plasma-treated and FCM-coated sample, and (c) N₂ plasma treated and FCM-coated sample after tenth wash.

The adhesion of FCM on cotton was additionally evaluated with the fragrance intensity of the functionalized fabric. The fragrance evaluation results, which are summarized in Table 4, show that the fragrance intensity of untreated and FCM-coated sample is strong, but gradually decreases with increasing number of washing cycles and completely disappears after 10 washing cycles. The same observation was made for O₂ plasma-treated and FCM-coated fabric, while N₂ plasma-treated and FCM-coated samples still contained a strong fragrance after 5 wash cycles. In the case of the N₂ plasma-treated and FCM-coated sample, the fragrance remained after 10 wash cycles, although somewhat weaker. The absence of the fragrance of untreated and O₂ plasma-treated and FCM-coated samples after repetitive washing is due to the removal of binder layer with entrapped FCM, as mentioned earlier. Although some microcapsules are still visible on the surface of these two samples after the tenth wash (Figure 6a,b), their quantity is so low and only very small microcapsules were present that most judges classified the samples as fragrance-free.

FTIR analysis provided additional—spectral—information about the behavior and properties between the untreated and plasma-treated samples, which were uncoated and FCM-coated. Since six recorded spectra are generally very similar to each other, differing significantly only in the absorption peaks at a few specific wavenumbers (Figure 7), PCA was used to visualize and interpret these differences.

Table 4. Fragrance intensity of unwashed and washed microcapsule-coated cotton fabrics expressed as number of responses for each treatment.

Sample	Number of Wash Cycles	Fragrance Intensity			
		Strong	Medium	Weak	Absent
Control *		0	0	0	30
Untreated	0	30	0	0	0
O ₂ plasma		30	0	0	0
N ₂ plasma		30	0	0	0
Untreated	1	2	28	0	0
O ₂ plasma		3	27	0	0
N ₂ plasma		29	1	0	0
Untreated	5	0	5	25	0
O ₂ plasma		0	3	27	0
N ₂ plasma		26	4	0	0
Untreated	10	0	0	1	29
O ₂ plasma		0	0	2	28
N ₂ plasma		1	27	2	0

* Control sample was not coated with fragrance microcapsules.

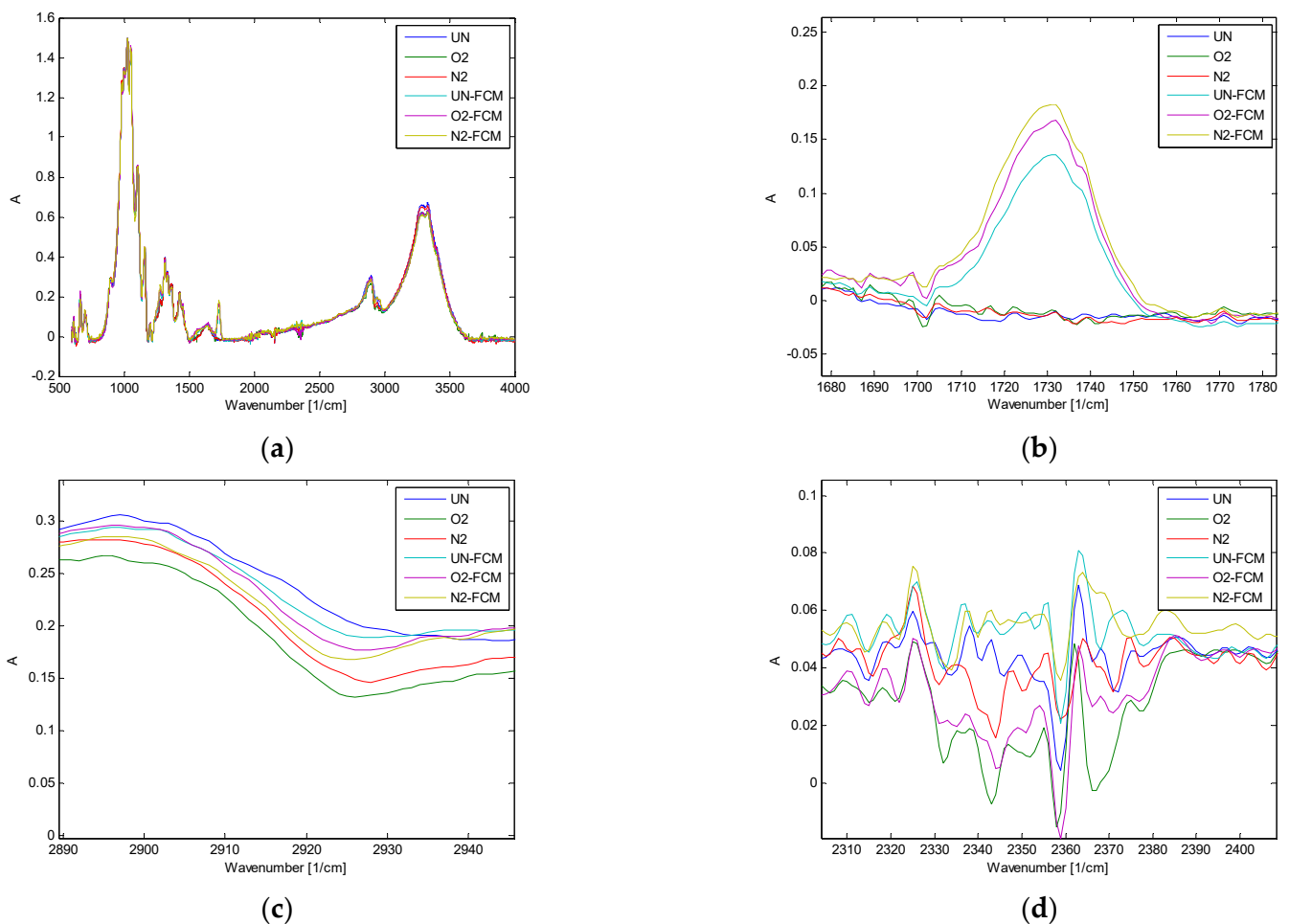

Figure 7. The (a) original FTIR spectra and (b–d) magnified views of three regions with most pronounced differences among the samples.

Figures 8a and 9a show score plots, i.e., relationships between the six samples under investigation, while Figures 8b–d and 9b–d show loading plots, i.e., correlations between the original variables (wavenumbers) and the first three PCs.

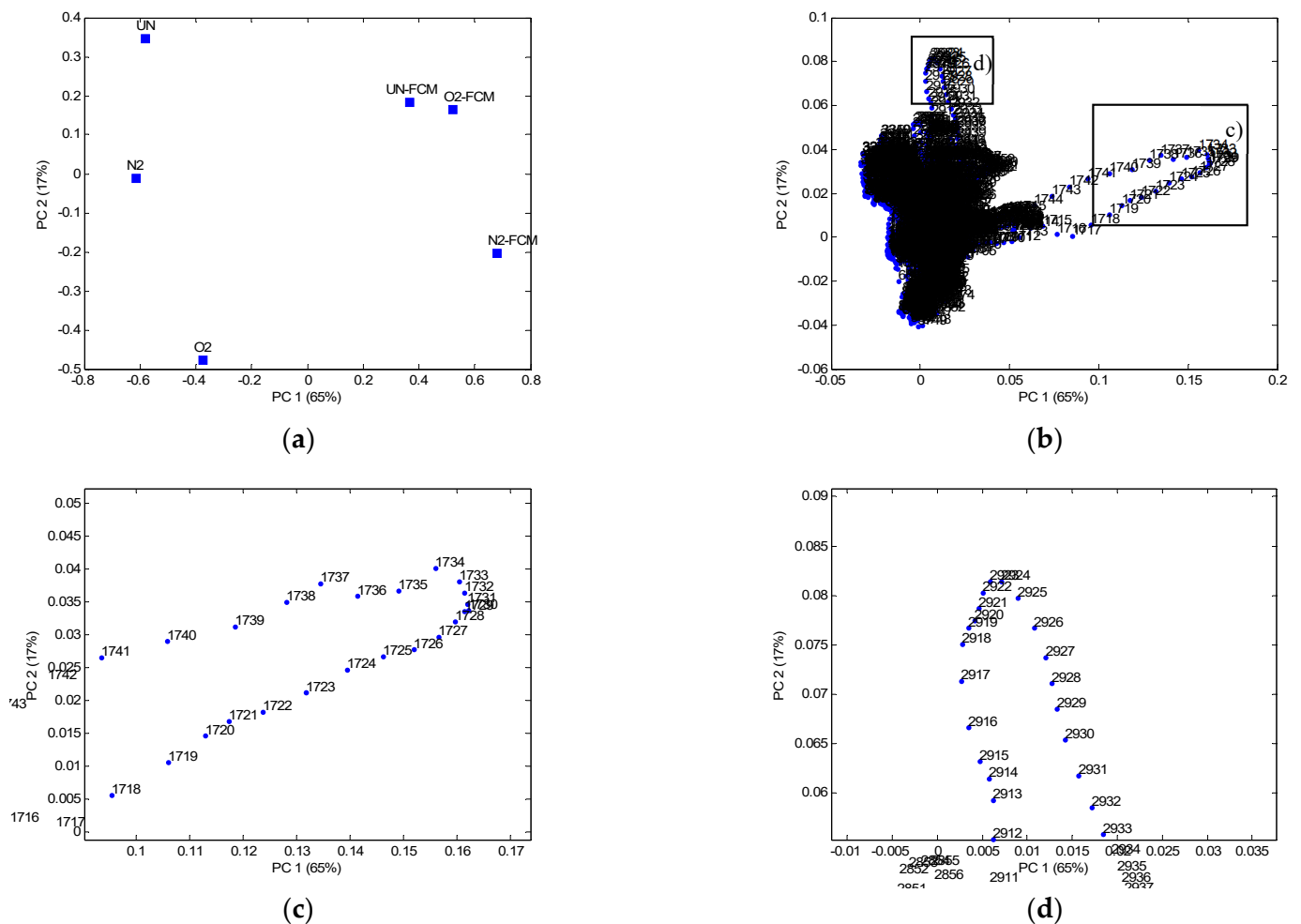

Figure 8. PC1-PC2 score plot (a) and PC1-PC2 loading plots (b–d).

A closer look at the original spectral data shows that the most striking difference between the uncoated and FCM-coated samples is the presence or absence of an absorption peak at wavenumber 1730 cm^{-1} (see Figure 7b). The PC1-PC2 score and loading plots—Figure 8a–c—confirm this fact. PC1, which accounts for most of the FTIR information (65%), distributes the samples horizontally from left to right according to their absorption at that wavelength (the rightmost data point in Figure 8c). While the uncoated samples on the left (UN, O₂, N₂) show no absorption, the three samples coated with FCM (UN-FCM, O₂-FCM, N₂-FCM) show strong peaks at this wavenumber. Moreover, the intensity peak of sample N₂-FCM is the highest, followed by samples O₂-FCM and UN-FCM, which means that more FCM was adsorbed on the cotton fabric after treatment with N₂ plasma. The absorption intensity of each sample corresponds to its horizontal constellation in Figure 8a. The samples also differ, albeit less clearly, in terms of their absorption intensity in the wavenumber region between $2915\text{--}2930\text{ cm}^{-1}$ (see Figure 7c). Accordingly, the vertical—i.e., along PC2—position of the samples in the PC1-PC2 score plot (Figure 8a) corresponds exactly to their absorption values at 2924 cm^{-1} : the untreated sample (UN) has the highest absorption, followed by UN-FCM, O₂-FCM, etc., while O₂ is characterized by the lowest absorption intensity. Finally, PC3, which accounts for only 10% of all spectral information, arranges the samples according to their absorption intensity in the $2330\text{--}2380\text{ cm}^{-1}$ region. As shown by the similarity of the positions of the samples and wavenumbers in Figure 9a,d, the absorption is strongest for the N₂-FCM sample (upper regions of both plots) and decreases towards O₂-FCM, which has the lowest absorption. These results are consistent with previous ones (i.e., SEM, fragrance intensity, and air

permeability). Examining the two score plots, one can assign a physical mean to two of the first three PCs. As mentioned above, PC1—the horizontal axis in Figure 8a—is related to the presence (N₂-FCM, O₂-FCM, UN -FCM) or absence of microcapsules (N₂, O₂, UN) on the samples. On the other hand, PC3—the vertical axis in Figure 9a—separates the samples in terms of presence and type of plasma treatment: in the upper part of the diagram, we find both N₂ plasma-treated samples (N₂-FCM and N₂), untreated samples (UN and UN-FCM) are located in the middle, while both O₂ plasma-treated samples (O₂, O₂-FCM) are found in the lower part of the diagram.

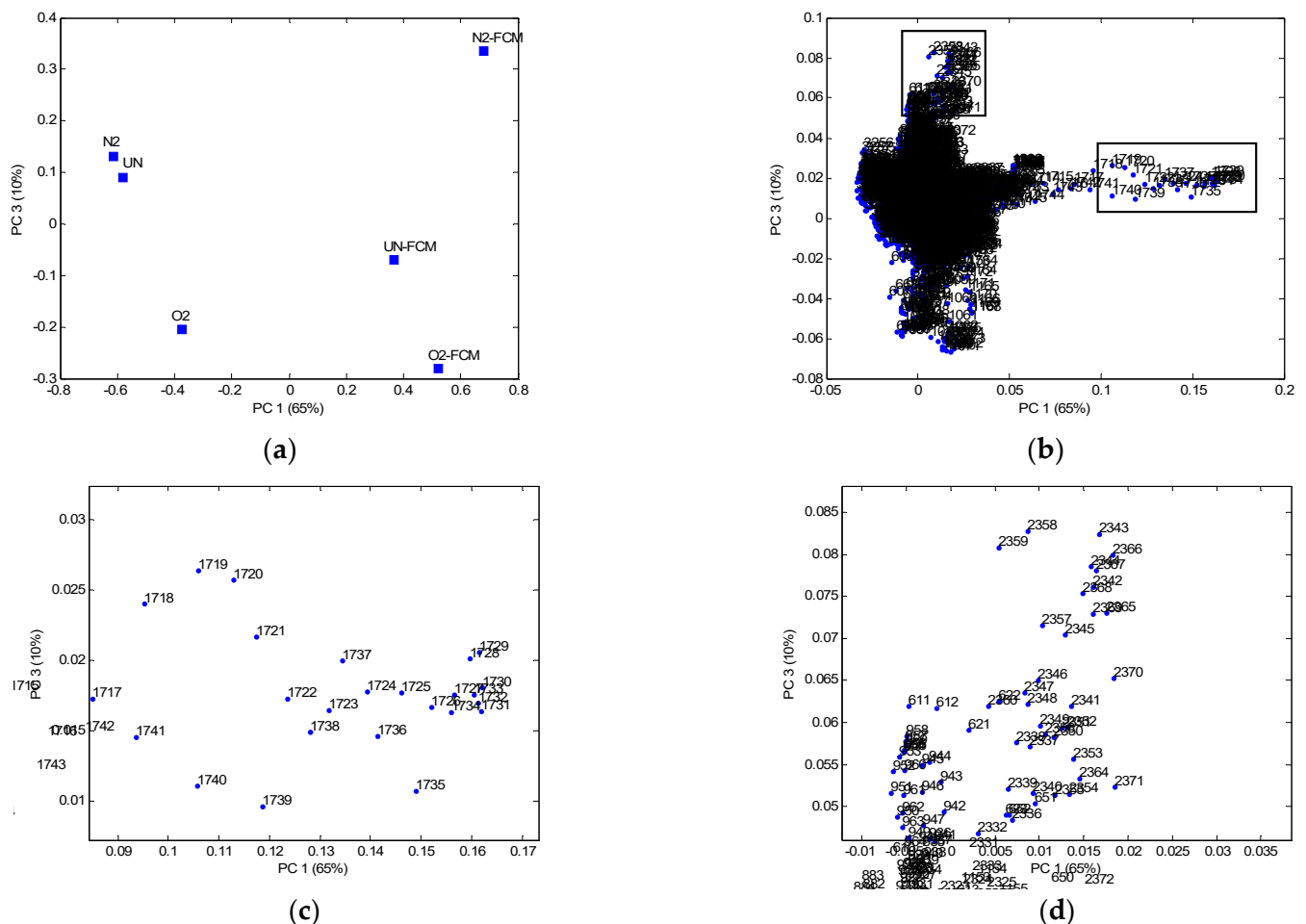

Figure 9. PC1-PC3 score plot (a) and PC1-PC3 loading plots (b–d).

4. Conclusions

In this study, cotton fabric was treated with a low-pressure capacitively coupled plasma system using oxygen or nitrogen gases and coated with fragrance microcapsules (FCM). The effect of plasma treatment was evaluated with SEM, the mechanical properties and wicking ability of the fabric, the adsorption of FCM on cotton with SEM and FTIR, and the adsorption and adhesion of FCM on cotton with the SEM, air permeability, and fragrance intensity after repetitive domestic washing. The results show that the plasma treatment with either of the two gases induces chemical surface changes of cotton, which allows higher adsorption of FCM. The higher etch rate of the O₂ plasma compared to the N₂ plasma also leads to changes in the morphology of the fibers, resulting in better interlocking of cellulose fibrils protruding from the fiber surface and increased tensile strength. The wicking ability of the plasma treated cotton fabric increased by 14% due to the incorporation of polar functional groups on the fiber surface. This allowed higher adsorption of FCM on fabrics, which was demonstrated by SEM, FTIR, and air permeability.

The air permeability and fragrance intensity of the samples slowly decreased after repeated washing. The N₂ plasma-treated and FCM-coated sample showed medium fragrance intensity and lower air permeability even after ten domestic washes, while the untreated and O₂ plasma-treated and FCM-coated samples showed almost no fragrance and higher air permeability. The grafting of nitrogen-rich groups onto the cellulose surface with N₂ plasma allows binding sites and electrostatic interactions with the anionic coating, which enable adsorption and adhesion. For further research, the different nitrogen-rich gases (i.e., N₂, NH₃) or their mixtures should be investigated for plasma generation to evaluate the optimal conditions for plasma treatment and careful design of textiles with microcapsules-enhanced wash resistance.

Author Contributions: Conceptualization, M.G. and N.P.; Methodology, M.G. and Z.L.P.; Formal analysis, M.G. and K.S.; Investigation, M.K., M.G., K.S. and N.P.; Resources, Z.L.P., P.F.T. and M.G.; Data curation, A.H.; Writing—original draft preparation, M.K., M.G., A.H. and N.P.; Writing—review and editing, M.K., P.F.T., Z.L.P., K.S. and N.P.; Visualization, M.K.; Supervision, M.G.; Funding acquisition, M.G., N.P., K.S. and Z.L.P. All authors have read and agreed to the published version of the manuscript.

Funding: The work was supported by Slovenian Research Agency (P2-0213, RIC UL-NTF, bilateral project). K.S. and N.P. are supported by MESTD of Republic of Serbia grant No. 451-03-68/2021-14/200024.

Institutional Review Board Statement: Not applicable.

Informed Consent Statement: Not applicable.

Data Availability Statement: Data sharing is not applicable to this article.

Conflicts of Interest: The authors declare no conflict of interest.

References

1. Cerempei, A. Aromatherapeutic textiles. In *Active Ingredients from Aromatic and Medicinal Plants*; El-Shemy, H.A., Ed.; InTech: Rijeka, Croatia, 2017; pp. 87–106.
2. Singh, N.; Sheikh, J. Microencapsulation and its application in production of functional textiles. *Indian J. Fibre Text* **2020**, *45*, 495–509.
3. Ghayempour, S.; Montazer, M. Micro/nanoencapsulation of essential oils and fragrances: Focus on perfumed, antimicrobial, mosquito-repellent and medical textiles. *J. Microencapsul.* **2016**, *33*, 497–510. [[CrossRef](#)]
4. Xiao, B.; Wang, W.; Zhang, X.; Long, G.; Fan, J.; Chen, H.; Deng, L. A novel fractal solution for permeability and Kozeny-Carman constant of fibrous porous media made up of solid particles and porous fibers. *Powder Technol.* **2019**, *349*, 92–98. [[CrossRef](#)]
5. Cristina, E.D. Understanding true aromatherapy: Understanding essential oils. *Home Health Care Manag. Pract.* **2004**, *16*, 474–479. [[CrossRef](#)]
6. Bonet-Aracil, M.; Monllor, P.; Capablanca, L.; Gisbert, J.; Díaz, P.; Montava, I. A comparison between padding and bath exhaustion to apply microcapsules onto cotton. *Cellulose* **2015**, *22*, 2117–2127. [[CrossRef](#)]
7. Bezerra, F.M.; Carmona, O.G.; Carmona, C.G.; Lis, M.J.; de Moraes, F.F. Controlled release of microencapsulated citronella essential oil on cotton and polyester matrices. *Cellulose* **2016**, *23*, 1459–1470. [[CrossRef](#)]
8. Boh, B.; Knez, E. Microencapsulation of essential oils and phase change materials for applications in textile products. *Indian J. Fibre Text. Res.* **2006**, *31*, 72–82.
9. Bonet-Aracil, M.; Capablanca, L.; Monllor, P.; Díaz, P.; Montava, I. Studying bath exhaustion as a method to apply microcapsules on fabrics. *J. Text. Inst.* **2012**, *103*, 629–635. [[CrossRef](#)]
10. Golja, B.; Šumiga, B.; Tavčer, P.F. Fragrant finishing of cotton with microcapsules: Comparison between printing and impregnation. *Color. Technol.* **2013**, *129*, 338–346. [[CrossRef](#)]
11. Li, S.; Boyter, H.; Qian, L. UV curing for encapsulated aroma finish on cotton. *J. Text. Inst.* **2005**, *96*, 407–411. [[CrossRef](#)]
12. Li, S.; Lewis, J.E.; Stewart, N.M.; Qian, L.; Boyter, H. Effect of finishing methods on washing durability of microencapsulated aroma finishing. *J. Text. Inst.* **2008**, *99*, 177–183. [[CrossRef](#)]
13. Oliveira, F.R.; Fernandes, M.; Carneiro, N.; Souto, A.P. Functionalization of wool fabric with phase-change materials microcapsules after plasma surface modification. *J. Appl. Polym. Sci.* **2013**, *128*, 2638–2647. [[CrossRef](#)]
14. Ghayempour, S.; Mortazavi, S.M. Microwave curing for applying polymeric nanocapsules containing essential oils on cotton fabric to produce antimicrobial and fragrant textiles. *Cellulose* **2015**, *22*, 4065–4075. [[CrossRef](#)]
15. Carmo, S.N.D.; Zille, A.; Souto, A.P. Plasma-assisted deposition of microcapsule containing *Aloe vera* extract for cosmeo-textiles. *IOP Conf. Ser. Mater. Sci. Eng.* **2017**, *254*, 122007. [[CrossRef](#)]

16. Guignard, M.I.; Campagne, C.; Giraud, S.; Brebu, M.; Vrinceanu, N.; Cioca, L.-I. Functionalization of a bamboo knitted fabric using air plasma treatment for the improvement of microcapsules embedding. *J. Text. Inst.* **2014**, *106*, 119–132. [[CrossRef](#)]
17. Shin, S.; Shin, J.E.; Yoo, Y.J. Attachment of alginate microcapsules onto plasma-treated PDMS sheet for retrieval after transplantation. *Biotechnol. Appl. Biochem.* **2013**, *60*, 617–622. [[CrossRef](#)] [[PubMed](#)]
18. Oliveira, F.R.; Silva, E.A.A.; Carmo, S.N.D.; Steffens, F.; Souto, A.P.G.D.V. Functionalization of natural cork composite with microcapsules after plasma treatment. *Adv. Mater. Sci. Eng.* **2014**, *2014*, 685829. [[CrossRef](#)]
19. Park, S.-J.; Kim, K.-S. Effect of oxygen plasma treatment on the release behaviors of poly (ϵ -caprolactone) microcapsules containing tocopherol. *Colloids Surf. B Biointerfaces* **2005**, *43*, 138–142. [[CrossRef](#)] [[PubMed](#)]
20. Gorjanc, M.; Mozetič, M.; Vesel, A.; Zaplotnik, R. Natural dyeing and UV protection of plasma treated cotton. *Eur. Phys. J. D* **2018**, *72*, 41. [[CrossRef](#)]
21. Štular, D.; Primc, G.; Mozetič, M.; Jerman, I.; Mihelčič, M.; Ruiz-Zepeda, F.; Tomšič, B.; Simončič, B.; Gorjanc, M. Influence of non-thermal plasma treatment on the adsorption of a stimuli-responsive nanogel onto polyethylene terephthalate fabric. *Prog. Org. Coat.* **2018**, *120*, 198–207. [[CrossRef](#)]
22. Gorjanc, M.; Savić, A.; Topalić-Trivunović, L.; Mozetič, M.; Zaplotnik, R.; Vesel, A.; Grujić, D. Dyeing of plasma treated cotton and bamboo rayon with *Fallopia japonica* extract. *Cellulose* **2016**, *23*, 2221–2228. [[CrossRef](#)]
23. Primc, G.; Tomšič, B.; Vesel, A.; Mozetič, M.; Ražič, S.E.; Gorjanc, M. Biodegradability of oxygen-plasma treated cellulose textile functionalized with ZnO nanoparticles as antibacterial treatment. *J. Phys. D Appl. Phys.* **2016**, *49*, 324002. [[CrossRef](#)]
24. Sun, Z.; Zhou, Y.; Li, W.; Chen, S.; You, S.; Ma, J. Preparation of silver-plated para-aramid fiber by employing low-temperature oxygen plasma treatment and dopamine functionalization. *Coatings* **2019**, *9*, 599. [[CrossRef](#)]
25. Ribeiro, A.I.; Senturk, D.; Silva, K.K.; Modic, M.; Cvelbar, U.; Dinescu, G.; Mitu, B.; Nikiforov, A.; Leys, C.; Kuchakova, I.; et al. Antimicrobial efficacy of low concentration PVP-silver nanoparticles deposited on DBD plasma-treated polyamide 6,6 fabric. *Coatings* **2019**, *9*, 581. [[CrossRef](#)]
26. Radetić, M.; Jocić, D.; Jovančić, P.; Rajaković, L.; Thomas, H.; Petrović, Z.L. Recycled-wool-based nonwoven material as a sorbent for lead cations. *J. Appl. Polym. Sci.* **2003**, *90*, 379–386. [[CrossRef](#)]
27. Radetić, M.M.; Jocić, D.M.; Jovančić, P.; Petrović, Z.; Thomas, H.F. Recycled wool-based nonwoven material as an oil sorbent. *Environ. Sci. Technol.* **2003**, *37*, 1008–1012. [[CrossRef](#)]
28. Mihailović, D.; Saponjic, Z.; Molina, R.; Puac, N.; Jovančić, P.; Nedeljkovic, J.; Radetić, M. Improved properties of oxygen and argon RF plasma-activated polyester fabrics loaded with TiO₂ nanoparticles. *ACS Appl. Mater. Interfaces* **2010**, *2*, 1700–1706. [[CrossRef](#)]
29. Makabe, T.; Petrović, Z.L. *Plasma Electronics: Applications in Microelectronic Device Fabrication*, 2nd ed.; CRC Press: New York, NY, USA, 2015; 360p.
30. Lieberman, M.A.; Lichtenberg, A.J. *Principles of Plasma Discharges and Materials Processing*; Wiley: Hoboken, NJ, USA, 2005.
31. Chabert, P.; Braithwaite, N. *Physics of Radio-Frequency Plasmas*; Cambridge University Press: Cambridge, UK, 2011; p. 394.
32. Gorjanc, M.; Mozetič, M.; Primc, G.; Vesel, A.; Spasić, K.; Puač, N.; Petrović, Z.L.; Kert, M. Plasma treated polyethylene terephthalate for increased embedment of UV-responsive microcapsules. *Appl. Surf. Sci.* **2017**, *419*, 224–234. [[CrossRef](#)]
33. Vesel, A.; Primc, G.; Zaplotnik, R.; Mozetič, M. Applications of highly non-equilibrium low-pressure oxygen plasma for treatment of polymers and polymer composites on an industrial scale. *Plasma Phys. Control. Fusion* **2020**, *62*, 024008. [[CrossRef](#)]
34. Primc, G.; Mozetič, M. Neutral reactive gaseous species in reactors suitable for plasma surface engineering. *Surf. Coat. Technol.* **2019**, *376*, 15–20. [[CrossRef](#)]
35. Golja, B.; Tavčer, P.F. Textile functionalisation by printing fragrant, antimicrobial and flame-retardant microcapsules. *Tekstilec* **2016**, *59*, 278–288. [[CrossRef](#)]
36. Golja, B.; Forte-Tavčer, P. Behaviour of printed melamine-formaldehyde microcapsules exposed to different mechanical impacts. In *Magic World of Textiles: Book of Proceedings, Proceeding of the 5th International Textile, Clothing & Design Conference, Dubrovnik, Croatia, 3–6 October 2010*; Dragčević, Z., Ed.; University of Zagreb: Zagreb, Croatia, 2010; pp. 360–364.
37. Golja, B. Funkcionalizacija Tekstilij z Nanosom Mikrokapsul. Ph.D. Thesis, University of Ljubljana, Ljubljana, Slovenia, 2013.
38. Puač, N.; Petrović, Z.L.; Živković, S.; Giba, Z.; Grubišić, D.; Đorđević, A.R. Low temperature plasma treatment of dry empress-tree seeds. In *Plasma Processes and Polymers*; D’Agostino, R., Favia, P., Oehr, C., Wertheimer, M.R., Eds.; Wiley: Weinheim, Germany, 2005; pp. 193–203.
39. Gorenšek, M.; Gorjanc, M.; Bukošek, V.; Kovač, J.; Petrović, Z.; Puac, N. Functionalization of polyester fabric by Ar/N₂ plasma and silver. *Text. Res. J.* **2010**, *80*, 1633–1642. [[CrossRef](#)]
40. *ISO 13934-1:2013 Textiles—Tensile Properties of Fabrics—Part 1: Determination of Maximum Force and Elongation at Maximum Force Using the Strip Method*; International Organization for Standardization: Geneva, Switzerland, 2013.
41. Gorjanc, M.; Bukošek, V.; Gorenšek, M.; Mozetič, M. CF₄ plasma and silver functionalized cotton. *Text. Res. J.* **2010**, *80*, 2204–2213. [[CrossRef](#)]
42. *ASTM D 1388-18 Standard Test Method for Stiffness of Fabrics*; ASTM International: West Conshohocken, PA, USA, 2018; Volume 07.01. [[CrossRef](#)]
43. Gorjanc, M.; Jazbec, K.; Maloprav, A.; Godec, M.; Forte-Tavčer, P.; Simončič, B. Creation of “lotus effect” on cotton fabric with use of plasma, enzymes and sol-gel finishing. *Tekstilec* **2012**, *55*, 206–214.

44. DIN 53924 *Testing of Textiles—Velocity of Soaking Water of Textile Fabrics (Method by Determining the Rising Height)*; German Institute for Standardization: Berlin, Germany, 2020.
45. ISO 9237:1995 *Textiles-Determination of Permeability of Fabrics to Air*; International Organization for Standardization: Geneva, Switzerland, 1995.
46. ISO 105-C06:2010 *Textiles—Tests for Colour Fastness—Part C06: Colour Fastness to Domestic and Commercial Laundering*; International Organization for Standardization: Geneva, Switzerland, 2010.
47. Jolliffe, I.T. *Principal Component Analysis*, 2nd ed.; Springer: New York, NY, USA, 2002; 487p.
48. Strlic, M.; Thomas, J.; Trafela, T.; Cséfalvayová, L.; Cigić, I.K.; Kolar, J.; Cassar, M. Material degradomics: On the smell of old books. *Anal. Chem.* **2009**, *81*, 8617–8622. [[CrossRef](#)]
49. Debeljak, M.; Hladnik, A.; Černe, L.; Gregor-Sveteč, D. Use of effect pigments for quality enhancement of offset printed specialty papers. *Color Res. Appl.* **2013**, *38*, 168–176. [[CrossRef](#)]
50. Mihailović, D.; Saponjic, Z.; Radoicic, M.; Lazovic, S.; Baily, C.J.; Jovančić, P.; Nedeljkovic, J.; Radetić, M. Functionalization of cotton fabrics with corona/air RF plasma and colloidal TiO₂ nanoparticles. *Cellulose* **2011**, *18*, 811–825. [[CrossRef](#)]
51. Flynn, C.; Byrne, C.; Meenan, B. Surface modification of cellulose via atmospheric pressure plasma processing in air and ammonia–nitrogen gas. *Surf. Coat. Technol.* **2013**, *233*, 108–118. [[CrossRef](#)]
52. Vesel, A.; Junkar, I.; Cvelbar, U.; Kovac, J.; Mozetic, M. Surface modification of polyester by oxygen- and nitrogen-plasma treatment. *Surf. Interface Anal.* **2008**, *40*, 1444–1453. [[CrossRef](#)]
53. Pransilp, P.; Pruettiphap, M.; Bhanthumnavin, W.; Paosawatyanong, B.; Kiatkamjornwong, S. Surface modification of cotton fabrics by gas plasmas for color strength and adhesion by inkjet ink printing. *Appl. Surf. Sci.* **2016**, *364*, 208–220. [[CrossRef](#)]
54. Vallon, S.; Hofrichter, A.; Drévilon, B.; Klemberg-Sapieha, J.; Martinu, L.; Poncin-Epaillard, F. Improvement of the adhesion of silica layers to polypropylene induced by nitrogen plasma treatment. *Thin Solid Film.* **1996**, *290–291*, 68–73. [[CrossRef](#)]
55. Ogawa, T.; Uematsu, S.; Gejyo, M. Surface composition and its stability of nitrogen corona treated polypropylene. *Kobunshi Ronbunshu* **2008**, *65*, 67–72. [[CrossRef](#)]
56. Shahidi, S.; Ghoranneviss, M. Comparison between oxygen and nitrogen plasma treatment on adhesion properties and antibacterial activity of metal coated polypropylene fabrics. *Fibers Polym.* **2012**, *13*, 971–978. [[CrossRef](#)]
57. Babaei, S.; Fekete, N.; Hoesli, C.A.; Girard-Lauriault, P.-L. Adhesion of human monocytes to oxygen- and nitrogen-containing plasma polymers: Effect of surface chemistry and protein adsorption. *Colloids Surf. B Biointerfaces* **2018**, *162*, 362–369. [[CrossRef](#)] [[PubMed](#)]



Helium atmospheric pressure plasma jet parameters and their influence on bacteria deactivation in a medium

Andrea Jurov^{1,2,a}, Nikola Škoro³, Kosta Spasić³, Martina Modic¹, Nataša Hojnik¹, Danijela Vujošević⁴, Milena Đurović⁴, Zoran Lj. Petrović^{5,6}, and Uroš Cvelbar^{1,2}

¹ Jozef Stefan Institute, Jamova 39, 1000 Ljubljana, Slovenia

² Jozef Stefan International Postgraduate School, Jamova 39, 1000 Ljubljana, Slovenia

³ Institute of Physics, University of Belgrade, Pregrevica 118, Belgrade 11080, Serbia

⁴ Center for Medical Microbiology, Institute of Public Health Montenegro, Dzona Dzeksona bb, 81000 Podgorica, Montenegro

⁵ Serbian Academy of Sciences and Arts, Knez Mihajlova 35, Belgrade 11001, Serbia

⁶ School of Engineering, Ulster University, York St., Belfast BT15 1ED, UK

Received 22 November 2021 / Accepted 25 January 2022

© The Author(s), under exclusive licence to EDP Sciences, SIF and Springer-Verlag GmbH Germany, part of Springer Nature 2022

Abstract. Atmospheric pressure plasmas are becoming relevant in local microbial deactivation and other combined effects of plasmas on living organisms. For this reason, our research was focussed on optimisation of atmospheric pressure plasma jet (APPJ) parameters to complete the deactivation of different bacteria strains in a medium. Different helium APPJ treatments with different discharge parameters were used, such as input voltages and gas flows. To better understand plasma properties behind complete bacteria deactivation at optimised discharge parameters, optical and electrical plasma jet diagnostics were performed, including electrical characterisation of the plasma source, optical emission spectroscopy of the plasma plume and intensified charged coupled device imaging of the discharge behaviour for every set of plasma parameters. Then, the resulting plasma liquid chemistry was assessed to establish the connections between reactive species generated in the gaseous and liquid phases. The most efficient deactivation was found for higher discharge powers and gas flow rates, and that was linked to higher densities of reactive oxygen and nitrogen species, especially hydrogen peroxide and medium solvated charges.

1 Introduction

It is well known that some microorganisms, such as bacteria, fungi and viruses, act as pathogens and induce various diseases. Moreover, microorganisms can cause food spoilage and damage to materials such as corrosion of plumbing systems. For these reasons, several conventional sterilisation techniques which lead to complete microbial deactivation or removal have been developed, including heating, filtration, chemical liquid agents and radiation. However, a disadvantage of these sterilisation techniques is that they can be used only on thermally resistant and chemically inert substrates, as those techniques can influence substrate properties [1].

In recent years, non-thermal atmospheric pressure plasmas have been proposed as an alternative to conventional sterilisation techniques. Most frequently reported is sterilisation with atmospheric pressure plasma jets (APPJs) due to their low operating temperatures and cost-effective operation [2–5]. APPJs are suitable for selective treatment of specific substrates as they contain more known inactivation agents without

the downsides of conventional sterilisation techniques. Research suggests that reactive oxygen species play the biggest role in bacteria inactivation, but UV radiation, electric field, other reactive species and charged particles also contribute to the process [5–8]. In this way, APPJs represent one of the most promising discharge candidates for different biological applications, including complete deactivation of bacteria [9–12].

This research tested the efficiency of a constructed APPJ on four different bacteria: *Escherichia coli*, *Staphylococcus aureus*, *Bacillus subtilis*, and *Bacillus stearothermophilus*. *B. stearothermophilus* and *B. subtilis* are spore-forming bacteria and the most commonly recognised and widely used biological indicators for monitoring the effectiveness of sterilisation processes. Spores are dormant bacterial structures, highly resistant to disinfectants and sterilising agents. Spore-forming bacteria are commonly found in processed foods and dairy products [13–15]. These bacteria were tested in order to see how an APPJ affects spore-forming bacteria. Additionally, *E. coli* and *S. aureus*, the most common pathogens in humans and widespread in nature (in hospitals and working and living surroundings), were selected. They are commonly found

^a e-mail: andrea.jurov@ijs.si (corresponding author)

in different environments, contaminating various items, medical tools and food, and can cause hospital infections and food poisoning, as well as medically severe and sometimes fatal infections [16–19]. Moreover, these bacterial strains are known to possibly be multidrug-resistant [20, 21]. In addition, these bacteria tend to form biofilms where bacteria are well protected from the outside agents. It has been shown that plasmas may sterilize even the biofilms as well as planktonic samples [22].

There have been many reports on atmospheric pressure plasma-induced bacteria deactivation and decontamination [23–27]. However, there is a knowledge gap in optimising plasma parameters so that complete bacteria deactivation in a medium can be achieved in the shortest (optimal) times. Therefore, this research focuses on finding the most efficient parameters of a non-thermal helium APPJ as one of the most frequently used sources for deactivating bacteria. For this purpose, various combinations of input DC power unit voltages and gas flows were tested. Appropriate diagnostics were done both on plasma source and discharge, and on medium bacteria were suspended in.

2 Experimental setup

2.1 Preparation of bacteria samples

The deactivation effect of an APPJ, operated with helium as a working gas, was investigated on four different types of bacteria: *B. stearothermophilus* (ATCC No. 7953), *B. subtilis* (ATCC No. 6633), *S. aureus* (ATCC No. 25923) and *E. coli* (ATCC No. 25922). Bacterial cultures were grown overnight on Columbia (COS) agar plates (bioMérieux SA, Marcy l’Etoile, France) at 55 °C for *B. stearothermophilus* and 37 °C for *B. subtilis*, *S. aureus* and *E. coli*. Bacteria were picked up with a loop and resuspended in sterile saline to obtain 0.5 McF (1.5×10^8 CFU/ml) initial bacterial suspension. The concentration was constant in all experiments. 100 μ l of these initial 0.5 McF bacterial suspensions was evenly transferred to a 96-well plate with a flat bottom. Bacterial suspensions were exposed to the He APPJ at a constant distance for different exposure times. The samples were treated each time in triplicates.

To determine viable counts and evaluate plasma treatment effects, the Miles and Misra viable count

technique on COS blood agar plate (bioMérieux SA, Marcy l’Etoile, France) was used. A 20 μ l properly diluted plasma-treated bacterial suspension, as well as a positive (untreated bacterial suspension) and negative control (sterile saline), was placed onto the blood agar plate. This procedure is depicted in Fig. 1. Measurements of the reactive species and pH were also conducted. Reactive species concentrations of NO_2^- and H_2O_2 were measured by a spectrophotometer (UV VIS Lambda 25) via colorimetric assays in sterile saline. The pH measurements were performed by a pH-meter (Sentron[®]) also in saline.

2.2 APPJ system

Bacteria-containing medium was treated by APPJ source which is designed to be handheld and highly portable, schematic of which is shown in Fig. 2. The portability of the device was facilitated by a small-size custom-made power source which is placed inside a 20 \times 12 \times 6 cm plastic box including connectors and switches. It was connected to a commercial DC power supply Voltcraft SPS12-12 W-A. The power source output signal amplitude was varied by changing the DC input signal voltage, at discrete voltages 3, 4.5, 6, 9 and 12 V. Based on the DC input voltage, the output signal at 16 kHz was supplied to the jet enabling plasma operation at several high voltages from 1200 to 3500 V (RMS values). The jet had a copper wire, which serves as needle-type powered electrode that was placed inside the glass tube with inner diameter of 2 mm and outer diameter of 4 mm. The tube itself is held by 125 mm long and 26 mm wide Teflon housing, from which it protrudes 8 mm on the one side. On the other side, the tube was connected to gas inlet and Bronkhorst Mass-View MV-194 flow controller. For these treatments, we used He as a working gas at various fixed flows (0.5, 1, 1.5 and 2 slm).

Optical characterisation comprised optical emission spectrometry and plasma imaging by using an intensified charged coupled device (ICCD) camera. Optical emission spectroscopy was performed with an Andor Shamrock 500i spectrometer equipped with iXon Ultra 897 as a detector. An optical fibre was used to receive the emission from the plasma plume and direct it to the entrance slit of the spectrometer. The fibre was positioned at a distance of 5 cm from the jet tube

Fig. 1 Schematic representation of the experimental protocol procedure

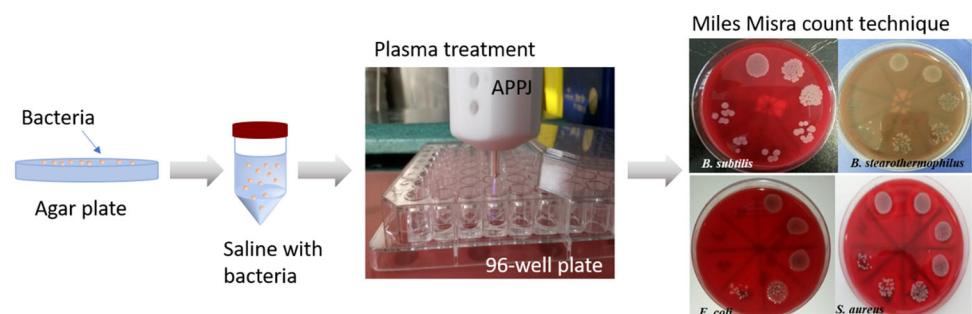

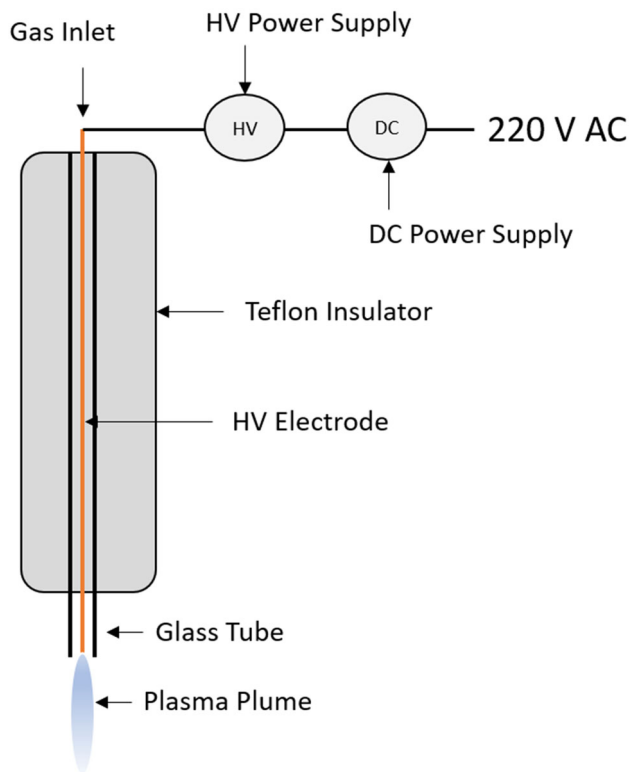

Fig. 2 Schematic representation of an APPJ used in this research

axis to gather the light coming from the whole channel volume. Recording of the spectra was performed for exposure times of 100 ms and with averaging of 10 spectrum acquisitions. Thus, obtained results represent space- and time-averaged emission from the plasma. Plasma imaging was performed with an Andor iStar ICCD camera DH334T-18U-03 equipped with a photographic objective. Images were taken in single-shot mode with an exposure time of 20 ms. Furthermore, electrical characterisation was performed by measuring the average power given to the jet. Voltage and current on the powered electrode were measured before the APPJ with an oscilloscope (Rigol DS1102E), high voltage probe (Rigol RP1018H) and current monitor (Pearson 8590C).

Estimation of saline solution evaporation during treatments was performed to evaluate changes in the treatment conditions throughout the experiments. For the longest treatment times, the highest DC supply voltages and He flow of 2 slm, the evaporated solution volume from the 96-well plate was not more than 50 μl . This change in volume caused a maximum liquid level reduction of 1.2 mm, thus increasing the distance between the plasma jet and the liquid surface. However, these changes did not drastically influence plasma properties, and these maximum values were reached only for the longest treatment times and plasma powers. For most treatment conditions, volume changes fell within the experimental error of transferring the liquid volume into the plate.

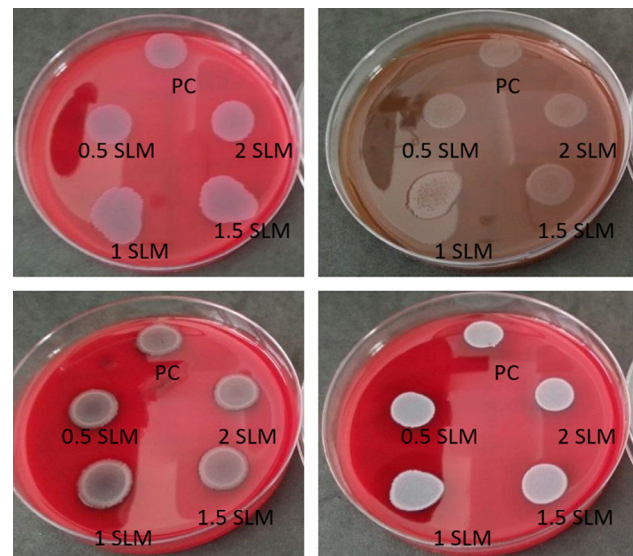

Fig. 3 Effect of gas flow-only (no plasma) treatment of bacteria **a** *B. subtilis*, **b** *B. stearothermophilus*, **c** *E. coli* and **d** *S. aureus* exposed to 0.5, 1, 1.5 and 2 slm compared to the positive control (PC) by Miles and Misra plate counting

3 Results and discussion

3.1 Bacteria deactivation

At first, bacterial suspension control samples were exposed only to helium gas flow with rates of 0.5, 1, 1.5 and 2 slm, without plasma and with no voltage applied, for the same duration as required for deactivation using the plasma. The obtained results exhibit no difference in bacteria viability (Fig. 3) compared to the untreated samples (positive control; PC), which confirms that helium alone is insufficient for bacteria deactivation. The effects of the APPJ were then further tested for all bacteria and analysed with a quantitative and informative approach, which involved dynamical studies of bacterial growth after treatments. Typically, survival curves were determined as the numbers of colony-forming units (CFUs; surviving culturable bacteria as a function of plasma treatment time). However, to limit the presentation, only complete bacteria deactivation, achieving sterility of the medium, is shown in Fig. 4.

Furthermore, Fig. 4 presents the time needed for complete deactivation of *E. coli*, *S. aureus*, *B. stearothermophilus* and *B. subtilis* within a medium, exposed to a He APPJ generated with different DC input powers and gas flows. If there are no data shown for a specific set of parameters (usually 3 V and 0.5 slm), the bacteria were not completely deactivated within the maximum treatment time of 240 s used in experiments. In most cases, it was found that *E. coli* was deactivated faster than other bacteria, proving to be a less plasma-resistant strain. In this case,

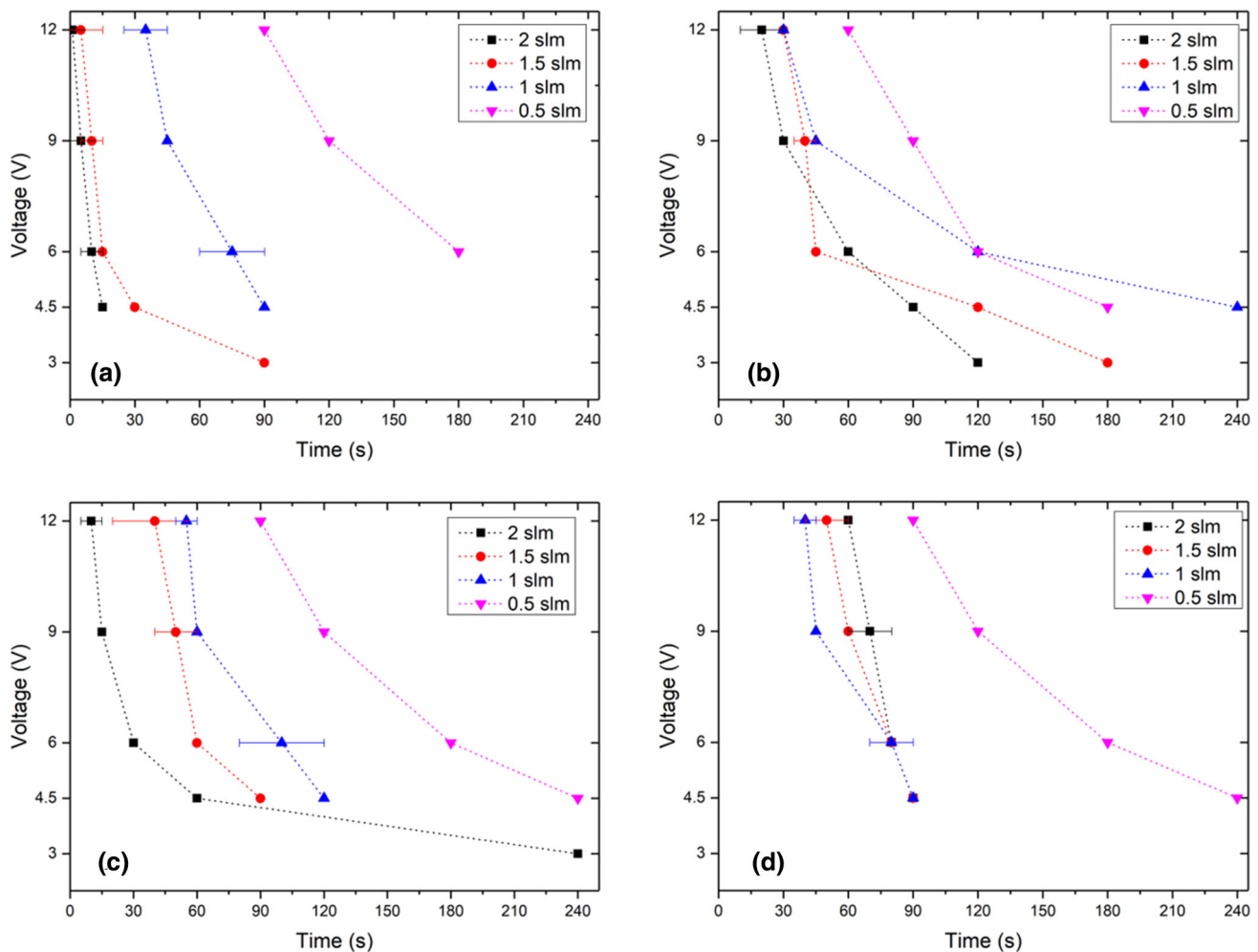

Fig. 4 Points of complete bacteria deactivation (the point at which the initial CFU/ml concentration drops to zero) **a** *E. coli*, **b** *S. aureus*, **c** *B. subtilis* and **d** *B. stearothermophilus* exposed to He APPJ generated with powers of 3, 6, 9 and 12 V, and flow rates of 0.5, 1, 1.5 and 2 slm

the highest treatment time was 180 s for deactivation under the lowest gas flow of 0.5 slm, which typically did not prove very efficient. *B. stearothermophilus* strains proved the most resistant to plasma treatments. Surprisingly, the lowest flow rate deactivation curves for 0.5 slm are very similar for all types of bacterial strains, except a small deviation with *E. coli*. This indicates that the APPJ generated at these conditions and its consequent reactive oxygen and nitrogen species (RONS) chemistry within the medium are similar (although, moving to higher flow rates, the chemistries and deactivations changed significantly). The trend follows the same patterns, where 0.5 slm is the least, and 2 slm is the most efficient, which are plasma properties connected to its subsequent interaction. The exception to this general rule is *B. stearothermophilus*, the most thermally stable and resistant strain, which seems to deviate from the rule. In this case, the most efficient chemistry for deactivation is at 1 slm. Chemical analyses of the medium chemistry elucidate the reasons for this behaviour in the following paragraphs.

From the perspective of the DC input voltage parameter used for jet discharge, the general rule is: the higher the energy input into discharge, the faster the deactivation of bacterial strains. However, it seems there is a minimum level at which the jets are efficient. It was found that an input DC voltage of 3 V was not sufficient to deactivate most bacteria strains even for the highest gas flow and treatment times because the plasma plume was the shortest and was not in direct contact with the substrate. If deactivation of the bacteria strain was achieved, then the treatment time was significantly prolonged. Therefore, the results indicate that He APPJ is most efficient at bacteria strain deactivation with higher applied power and higher gas flows, considering marked limits in discharge parameters and experimental constraints. We do not reach conditions where additional heating would produce thermal necrosis (40 °C) in the covered range of powers. While increasing efficiency with power is expected as for the flow, one could expect that beyond some point, further increasing of the flow may reduce efficiency by affecting the chain of

plasma chemical events needed to produce the radicals that cause sterilization.

3.2 Chemical analysis of reactive species of saline medium treated by APPJ

To explain the obtained results for bacterial deactivation in a medium, the initiated medium chemistry was investigated, determining RONS species, especially H_2O_2 and NO_2^- concentrations of the APPJ treated saline solution. Immediately after treatments, we performed measurements of pH changes. These parameters are known to influence the viability of bacterial strains significantly, as marked by numerous reports [28–31].

pH measurements were made under the same conditions as for reactive species measurement. The influence of different He plasma parameters (different gas flow rates of 0.5, 1, 1.5 and 2 slm and different input DC powers of 3, 4.5, 6, 9 and 12 V) on pH value was systematically measured. A pH value decrease was observed during the plasma treatment for most cases (Fig. 5). These decreasing trends featured an initial drop and then a steady decrease. An exception was 1 slm, which had an increasing pH trend for input DC voltage of 3 V. This could be explained by the fact that the plasma jet did not touch the surface of the liquid, and in this case, the chemistry of the medium was different than in other cases.

Reactive species concentrations of NO_2^- and H_2O_2 were determined after plasma treatment of saline; 50 μl of sterile saline was placed in the 96-well plate with a flat bottom. The distance between the bottom of the well and the APPJ orifice was 15 mm, as for the treatment of bacteria, and was kept constant during the treatment. The results are presented in Fig. 6, and the results are obtained with only the parameters yielding the most efficient plasma treatment—input voltage of 12 V and a flow rate of 2 slm. An expected, steady increase of H_2O_2 concentrations was observed for increasing treatment time. In contrast, the concentration of NO_2^- increased until 30 s, where it reached its maximum value and then started decreasing. The concentration dropped to zero after 120 s. This could be explained through decreasing of the pH value during the treatment. NO_2^- is very sensitive to low pH values, which is the cause of its decomposition or transformation into other compounds [32].

3.3 Diagnostics of the plasma source

In order to analyse properties of the plasma used for treatments, we performed diagnostic experiments at the same conditions as when treating media with bacterial strains. Due to safety, a saline medium was used without bacteria for these measurements.

Power measurements were made via electrical characterisation, where the average power (P_{avg}) input into

the jet was measured. This was calculated over 30 periods of current and input voltage as:

$$P_{\text{avg}} = \frac{1}{30T} * \int_{t_1}^{t_2} P(t) dt,$$

where T is oscillation period, and $P(t)$ is instantaneous power in every moment t calculated as $I(t) * V(t)$ from the beginning t_1 and end t_2 of 30 periods. The measurements were performed on the electrode before the plasma jet coming out of the tube and at two gas flow rates of 1 and 2 slm. The calculated values present an average power that the power source gives to the plasma jet (Fig. 7 left axis) and represents the ‘real’ power input into plasma. In order to link electrode voltage and power and to facilitate comparison to the other experimental data, we calculated V_{RMS} values as a function of input DC voltage (Fig. 7 right axis). The RMS values were calculated for 30 periods assessing several $V(t)$ signals at the same DC voltage in order to estimate differences. The measurements were performed on the electrode at two gas flow rates of 1 and 2 slm. It was observed that the power was not influenced by the gas flow rate but was instead dependent on the DC input voltage and provided powers in the range of 0.1–1.5 W. The power that is transferred from plasma to the treated samples is somewhat lower than calculated power since part is always lost.

Optical emission spectroscopy was used as a plasma diagnostic tool. A typical spectrum of He discharge of an APPJ at gas flow rate of 2 slm where a jet was positioned above the saline solution target is presented in Fig. 8. The spectrum was recorded in a wide range of wavelengths, between 300 and 800 nm. The characteristic spectrum of excited species has already been assessed for this kind of plasma jet [33–35]. The most intense lines came from the molecular OH (A–X) band, atomic lines of He and O, and molecular bands of N_2 ; the second positive system (SPS) and the first positive system as well as from the nitrogen ion—the first negative system (FNS) [36, 37]. Excited He atoms were produced from the ground state neutrals in the working gas used in the system. At the same time, OH and N_2 bands and atomic O lines and H α line were present since the experiments were conducted in an ambient air (with some humidity) and in contact with the saline solution. Neutral species from the surrounding air were mixed with the helium flow and therefore participated in gas phase reactions induced by plasma [38, 39]. In contrast to the case where solid NaCl was treated [40], the spectrum obtained with saline solution did not show any additional lines from Na (or Cl). This suggests that these species were not excited in the gas phase above the water for the plasma source to excite them.

Additional analysis regarding line intensity was performed on specific atomic and molecular lines for different DC input voltages used in the experiment (3, 4.5, 6, 9 and 12 V) at two gas flows (1 and 2 slm). The intensities at different discharge parameters with two emission lines from N_2 SPS (337.1 nm and 315.9 nm), head

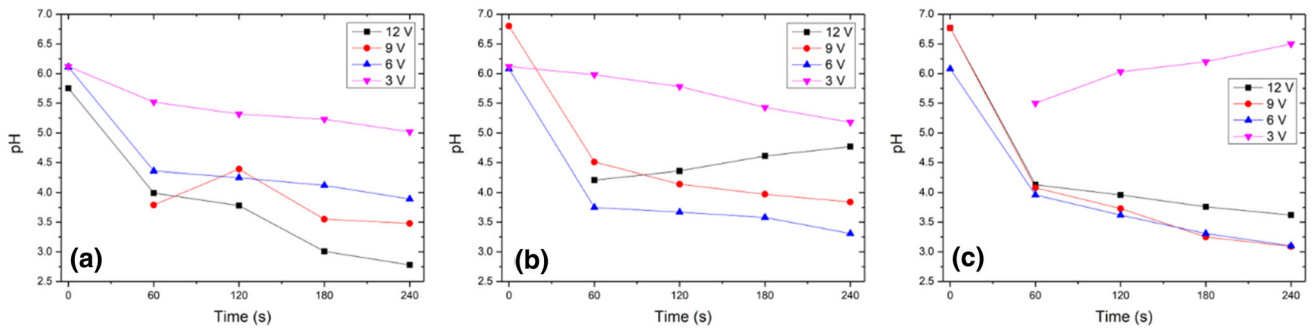

Fig. 5 pH values of He APPJ treated saline for gas flow of a 2 slm, b 1.5 slm and c 1 slm

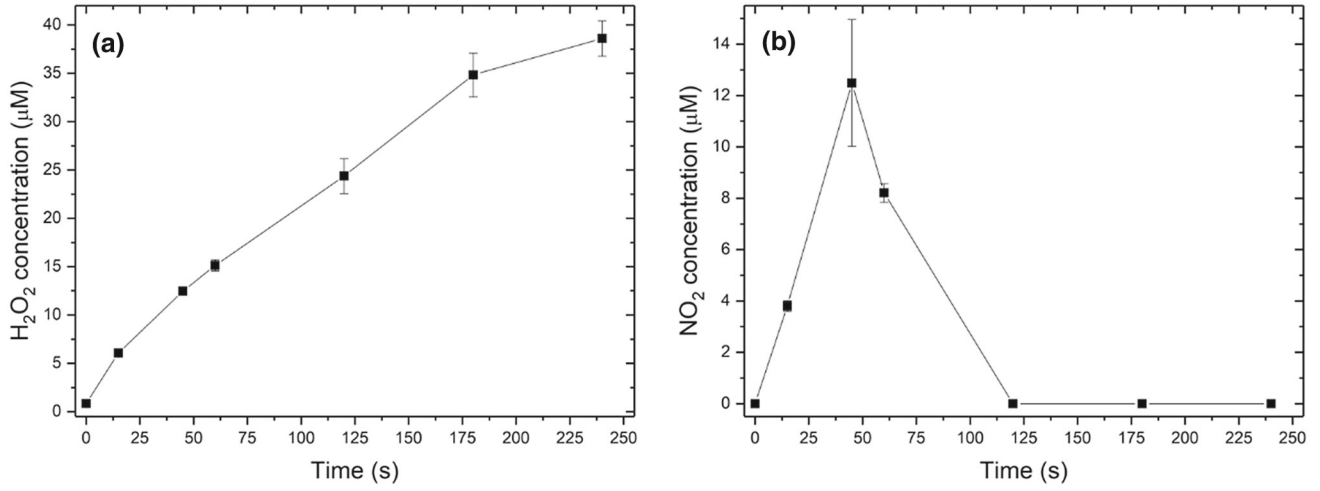

Fig. 6 Concentration of reactive species: a H_2O_2 and b NO_2^- with respect to treatment time

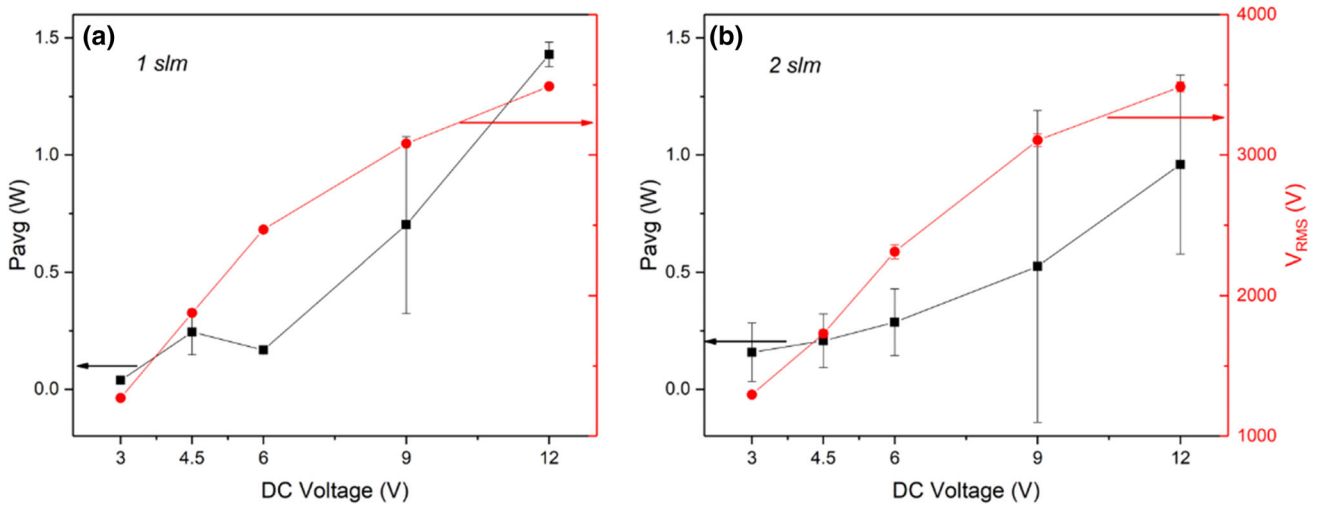

Fig. 7 Average input power to the plasma jet for He gas flows of a 1 slm and b 2 slm

Fig. 8 Optical emission spectroscopy of the He APPJ with a characteristic spectrum generated during the treatments above the liquid medium

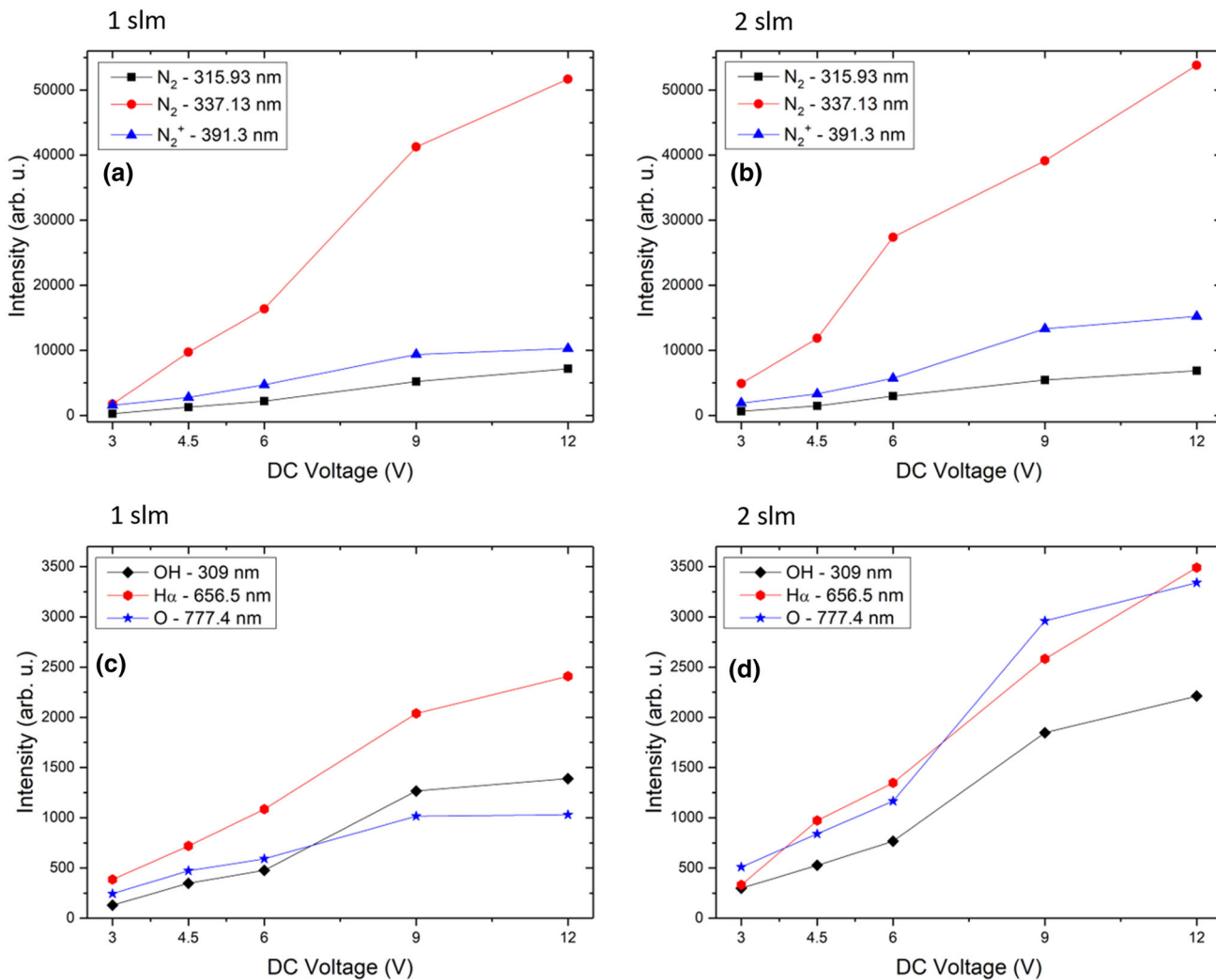
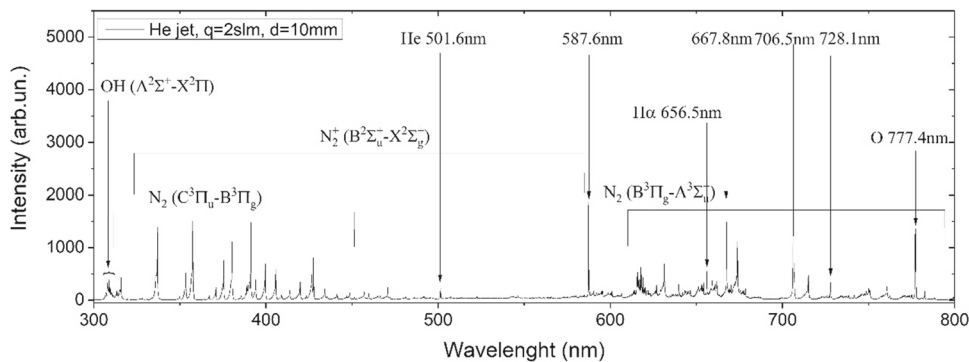

Fig. 9 Optical emission spectroscopy: intensities of certain atomic and molecular lines of nitrogen (a for 1 slm and b for 2 slm), and hydrogen, oxygen and hydroxyl c for 1 slm and d for 2 slm)

line from FNS N_2^+ (391.3 nm), the strongest molecular OH line (309 nm), $H\alpha$ (656.6 nm) and O atom line (777.4 nm) are presented in Fig. 8, while He line (706.5 nm) intensities are depicted in Fig. 9. All line intensities are normalised to the same recording conditions and corrected for spectral efficiency of the system, thus allowing direct intensity comparison between different lines. The position of the jet and the distance to the bottom of the 96-well plate were the same as for the treatments of bacteria. There was an increase in intensities for all observed lines when the source power (DC voltage) was increased. The increase of He flow had a minor influence on line intensities, resulting in a somewhat higher line intensity. In all cases, there was a stronger or weaker ‘jump’ between the emission intensities recorded for 6 V and 9 V. This change in peak values occurred due to the change in plasma regime since, as observed with the naked eye, the plasma channel did not connect to the surface of the saline until the 9 V were reached [41]. Therefore, the intensities recorded for voltages below 9 V can be regarded as free-standing jet cases, while for the voltages of 9 V and 12 V, plasma plume was in contact with the liquid surface.

The highest line intensities belong to the mainline of N_2 SPS, and these intensities have pronounced increments between 6 and 9 V input voltage (Fig. 9a and b). The second strongest line of the same band has a much lower increase in intensity. However, excitation of both of the excited levels in N_2 probably happened through electron collisions with the ground state or excited N_2 molecules [35, 42]. The increasing line intensity tendency is in accordance with the dependence observed with similar jet configurations [34]. The intensity of the strongest of FNS N_2^+ lines at 391.3 nm also increased with DC voltage, yet much less than the 337.1 nm line (Fig. 9a and b). This line comes from the excited state of N_2^+ ions that were efficiently produced in the Penning ionisation process, involving He metastables [43] and the direct electron impact ionisation process [42]. Consequently, an increase in He flow made the emission of the 391.3 nm line rise. On the other hand, lines from the OH band and $H\alpha$ came from dissociation of water vapour molecules in plasma [35, 44]. In this jet configuration, the amount of water vapour present in the surrounding air was sufficient to produce several excited species of OH and H visible in the emission spectrum. An increase in the He flow and discharge voltage resulted in the increase of OH emission intensity (Fig. 9c and d), which has been observed before [34, 45]. The atomic O (777.4 nm) line exhibited similar behaviour. Production of both OH and O species is important when it comes to the treatment of bacteria.

The intensity trend of the He line at 706.5 nm was similar to that of other spectral lines and is presented in Fig. 10. As expected, line intensity was observed to increase when we increase either working gas flow or DC input voltage. This He line is the most intense compared to other lines observed in the spectrum (Fig. 10). The result is due to amount of He and its mixture with air present in the plasma plume.

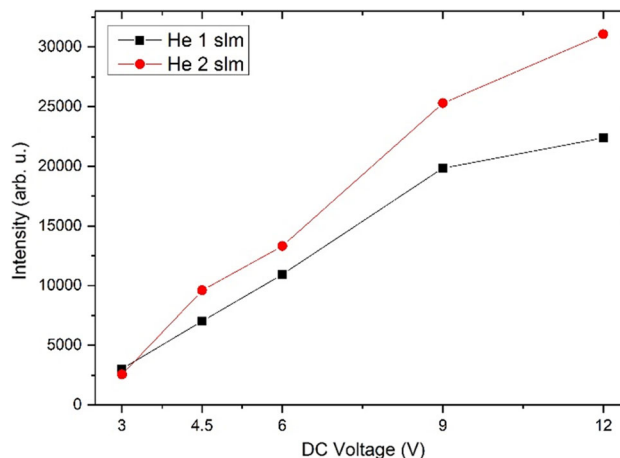
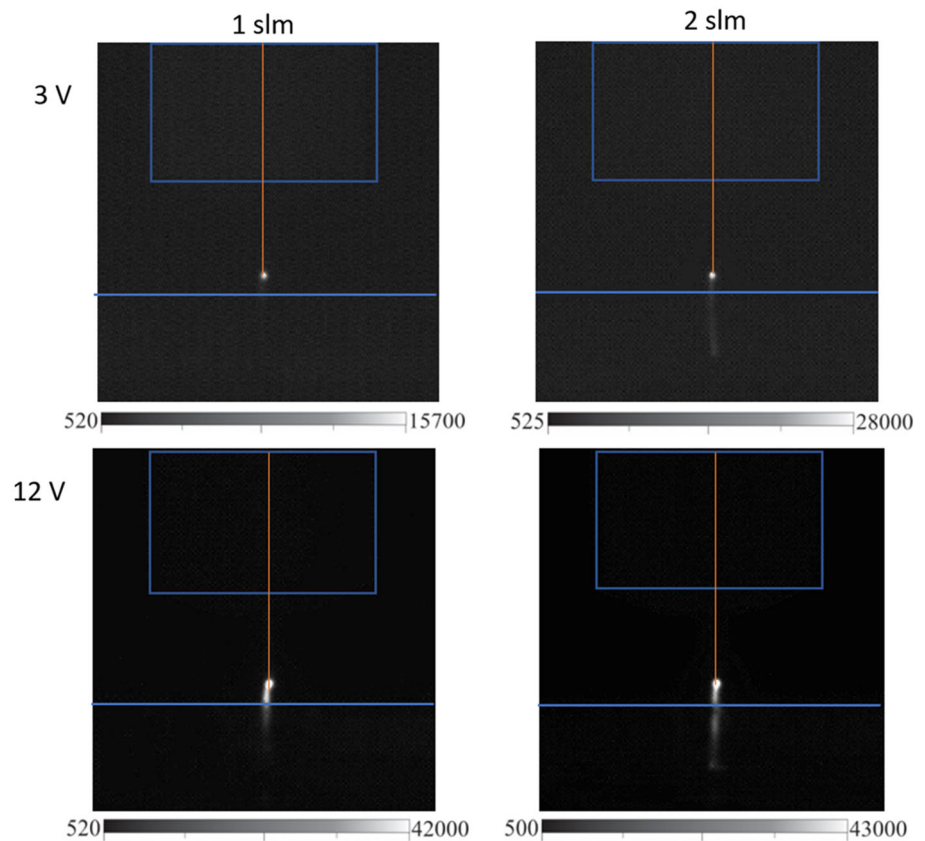

Fig. 10 He 706.5 nm line intensities for different gas flow and voltages

Observing all line intensities analyzed here, one can conclude that within the range of voltages varied in the experiment, there is a steady increase of the line intensity with increase in applied voltage. This reflects a fact that for all lines, i.e. processes related to specific emission, concentration of excited species continuously rises with voltage increment, without any abrupt changes. Hence, we can say that both voltage and flow changes applied here do not influence plasma chemistry but only concentration of species involved in the processes.

Discharge imaging can provide information about the way plasma plume forms and how it propagates between electrode and bacteria-containing medium. Additionally, a relative abundance of active species can be roughly assessed through emission intensity as brighter intensity corresponds to more emitting particles. For this, ICCD imaging was employed with time-averaged images of the streamer structure obtained for all He flows and DC input powers. Typical results are presented in Fig. 11 for 1 slm and 2 slm, at only the lowest (3 V) and highest (12 V) DC voltages used in the experiments. Similar to optical emission measurements, the jet position and its distance to the liquid surface in the 96-well plate were the same as for bacteria treatments. For all conditions, a ball-shaped bright plasma was visible on the tip of the pin electrode with a plasma plume extending towards the target. For the lowest DC voltage employed, a weak plasma channel existed only for the 2 slm flow of He. Obviously, for $V_{DC} = 3$ V and 1 slm of He, the field attained at the electrode with these power supply conditions was not enough to achieve sufficient ionisation in the whole volume between the jet and sample surface. At the highest power, i.e. DC voltage of 12 V, a streamer-like plasma channel with strong emission bridged the distance from the electrode tip to the liquid surface. After processing all images recorded by subtracting the background intensity level, it was determined that in all applied conditions, except for 3 V at 1 slm, the plasma plume reached the liquid surface, meaning that streamer length in this range of conditions did not depend on either voltage or helium flow.

Fig. 11 Images of the discharge structure at different flows and DC voltages from the power supply. A thin vertical line represents a pin electrode protruding from the body of the jet (rectangle shape). The horizontal line in the lower part of the images signifies the upper edge of the 96-well plate



This indicates that the medium chemistry of bacteria deactivation depends on streamer forming behaviour, which almost doubles the procedure's efficacy.

4 Conclusion

To optimise bacteria deactivation in media and obtain sterilisation with plasmas, a parameter study involving a large number of experiments using different plasma conditions was performed. It included monitoring the viability of different bacteria strains with respect to several plasma diagnostics measurements. This research clearly shows non-thermal helium APPJs' ability to deactivate four standard strains of bacteria used in such experiments. The deactivation effects of the plasma jet were significant and dependant on the bacterial strain, exposure time and plasma configuration (gas flow rate and input DC power unit voltage). The obtained results are expected and indicate that *E. coli* is deactivated faster than other strains. Generally, all bacterial strains—*E. coli*, *S. aureus*, *B. stearothermophilus* and *B. subtilis*—follow the same deactivation trends. The only discrepancy is in the optimal parameters for deactivation of *B. stearothermophilus*, where optimal deactivation is reached at lower flow rate levels. This might be because of the bacterial strain's properties and its response to the changing environment by

interacting plasma. The interaction of plasma and bacteria suspension (saline) was twofold—it changed the concentration of reactive species and pH in the solution with bacteria. This RONS species (He, O, N, H, photons) generated in the gas phase and high-energy electrons and ions were interacting with the liquid. As a result of the combined action of produced reactive species and chemical reactions, which also influenced the pH in the liquid phase, increased bacteria deactivation efficacy. Combining all the chemically initiated processes managed to sterilise given bacterial strains in a medium in fairly short treatment times, maximum efficacy was observed at high flow rates and DC input powers. More power transferred into the plasma shortens the deactivation process. Increasing the flow rate from 0.5 to 2 slm also shortens the inactivation process as reactive species concentration in the gas phase rises.

Acknowledgements This work was carried out within projects NATO SPS, and Slovenian Research Agency grant J4-1770. This article is also based upon work from COST Action PLAGRI—CA19110, supported by COST (European Cooperation in Science and Technology), www.cost.eu. K. S. acknowledges also partial funding from bilateral project Serbia-Slovenia from MESTD of Republic of Serbia. We thank Dr. Nevena Puac for useful advices related to electrical characterization.

Author contributions

UC and ZLP conceived and planned the experiments. NH, MM, DV and MĐ performed plasma treatment of bacteria and liquid chemistry analyses along with the interpretation of those results. NŠ, KS and AJ performed plasma diagnostics and electrical characterization along with interpretation of those results. AJ wrote the original draft, and all co-authors helped with manuscript revision.

Data availability statement This manuscript has no associated data or the data will not be deposited. [Authors' comment: Data available on request from the authors - The data that support the findings of this study are available from the corresponding author, A. J., upon reasonable request.]

References

- Z. Dai, J. Ronholm, Y. Tian, B. Sethi, X. Cao, Sterilization techniques for biodegradable scaffolds in tissue engineering applications. *J. Tissue Eng.* **7**, 204173141664881 (2016). <https://doi.org/10.1177/2041731416648810>
- J. Ehlbeck et al., Low temperature atmospheric pressure plasma sources for microbial decontamination. *J. Phys. D Appl. Phys.* (2011). <https://doi.org/10.1088/0022-3727/44/1/013002>
- R. Ben Gadri et al., Sterilization and plasma processing of room temperature surfaces with a one atmosphere uniform glow discharge plasma (OAUGDP). *Surf. Coat. Technol.* **131**(1–3), 528–541 (2000). [https://doi.org/10.1016/S0257-8972\(00\)00803-3](https://doi.org/10.1016/S0257-8972(00)00803-3)
- P.M. Schneider, New technologies and trends in sterilization and disinfection. *Am. J. Infect. Control* **41**(5 SUPPL.), S81–S86 (2013). <https://doi.org/10.1016/j.ajic.2012.12.007>
- A. Sakudo, Y. Yagyu, T. Onodera, Disinfection and sterilization using plasma technology: fundamentals and future perspectives for biological applications. *Int. J. Mol. Sci.* (2019). <https://doi.org/10.3390/ijms20205216>
- M. Laroussi, Nonthermal decontamination of biological media by atmospheric-pressure plasmas: review, analysis, and prospects. *IEEE Trans. Plasma Sci.* **30**(4I), 1409–1415 (2002). <https://doi.org/10.1109/TPS.2002.804220>
- X. Liao et al., Bacterial spore inactivation induced by cold plasma. *Crit. Rev. Food Sci. Nutr.* **59**(16), 2562–2572 (2019). <https://doi.org/10.1080/10408398.2018.1460797>
- H. Halfmann, B. Denis, N. Bibinov, J. Wunderlich, P. Awakowicz, Identification of the most efficient VUV/UV radiation for plasma based inactivation of *Bacillus atrophaeus* spores. *J. Phys. D Appl. Phys.* **40**(19), 5907–5911 (2007). <https://doi.org/10.1088/0022-3727/40/19/019>
- S. Hofmann, Atmospheric pressure plasma jets - characterisation and interaction with human cells and bacteria, no. december. (2013)
- M. Keidar, E. Robert, Preface to special topic: plasmas for medical applications. *Phys. Plasmas* **22**(12), 121901 (2015). <https://doi.org/10.1063/1.4933406>
- M. Keidar, D. Yan, I.I. Beilis, B. Trink, J.H. Sherman, Plasmas for treating cancer: opportunities for adaptive and self-adaptive approaches. *Trends Biotechnol.* **36**(6), 586–593 (2018). <https://doi.org/10.1016/j.tibtech.2017.06.013>
- S. Schneider et al., The role of VUV radiation in the inactivation of bacteria with an atmospheric pressure plasma jet. *Plasma Process. Polym.* **9**(6), 561–568 (2012). <https://doi.org/10.1002/ppap.201100102>
- N. Gopal, C. Hill, P.R. Ross, T.P. Beresford, M.A. Fenelon, P.D. Cotter, The prevalence and control of *Bacillus* and related spore-forming bacteria in the dairy industry. *Front. Microbiol.* (2015). <https://doi.org/10.3389/fmicb.2015.01418>
- S. André, T. Vallaëys, S. Planchon, Spore-forming bacteria responsible for food spoilage. *Res. Microbiol.* **168**(4), 379–387 (2017). <https://doi.org/10.1016/j.resmic.2016.10.003>
- S. Caulier, C. Nannan, A. Gillis, F. Licciardi, C. Braggard, J. Mahillon, Overview of the antimicrobial compounds produced by members of the *Bacillus subtilis* group. *Front. Microbiol.* (2019). <https://doi.org/10.3389/fmicb.2019.00302>
- J. Vila et al., *Escherichia coli*: an old friend with new tidings. *FEMS Microbiol. Rev.* **40**(4), 437–463 (2016). <https://doi.org/10.1093/femsre/fuw005>
- J. Jang, H.-G. Hur, M.J. Sadowsky, M.N. Byappanahalli, T. Yan, S. Ishii, Environmental *Escherichia coli*: ecology and public health implications—a review. *J. Appl. Microbiol.* **123**(3), 570–581 (2017). <https://doi.org/10.1111/jam.13468>
- T.J. Foster, J.A. Geoghegan, *Staphylococcus aureus*, in *Molecular Medical Microbiology*. (Elsevier, Amsterdam, 2015), pp. 655–674
- S.Y.C. Tong, J.S. Davis, E. Eichenberger, T.L. Holland, V.G. Fowler, *Staphylococcus aureus* Infections: epidemiology, pathophysiology, clinical manifestations, and management. *Clin. Microbiol. Rev.* **28**(3), 603–661 (2015). <https://doi.org/10.1128/CMR.00134-14>
- S. Basak, P. Singh, M. Rajurkar, Multidrug resistant and extensively drug resistant bacteria: a study. *J. Pathog.* **2016**, 1–5 (2016). <https://doi.org/10.1155/2016/4065603>
- L. Poirel et al., Antimicrobial resistance in *Escherichia coli*. *Microbiol. Spectr.* (2018). <https://doi.org/10.1128/microbiolspec.ARBA-0026-2017>
- M. Miletić et al., Inhibition of methicillin resistant *Staphylococcus aureus* by a plasma needle. *Open Phys.* (2014). <https://doi.org/10.2478/s11534-014-0437-z>
- A.H. Asghar, O.B. Ahmed, A.R. Galaly, Inactivation of *E. Coli* using atmospheric pressure plasma jet with dry and wet argon discharges. *Membranes* (Basel) **11**(1), 1–20 (2021). <https://doi.org/10.3390/membranes11010046>
- A. Moldgy, G. Nayak, H.A. Aboubakr, S.M. Goyal, P.J. Bruggeman, Inactivation of virus and bacteria using cold atmospheric pressure air plasmas and the role of reactive nitrogen species. *J. Phys. D Appl. Phys.* **53**(43), 434004 (2020). <https://doi.org/10.1088/1361-6463/aba066>

25. J.-W. Lackmann, J.E. Bandow, Inactivation of microbes and macromolecules by atmospheric-pressure plasma jets. *Appl. Microbiol. Biotechnol.* **98**(14), 6205–6213 (2014). <https://doi.org/10.1007/s00253-014-5781-9>
26. C.A.J. van Gils, S. Hofmann, B.K.H.L. Boekema, R. Brandenburg, P.J. Bruggeman, Mechanisms of bacterial inactivation in the liquid phase induced by a remote RF cold atmospheric pressure plasma jet. *J. Phys. D Appl. Phys.* **46**(17), 175203 (2013). <https://doi.org/10.1088/0022-3727/46/17/175203>
27. F. Saadati, H. Mahdikia, H.A. Abbaszadeh, M.A. Abdollahifar, M.S. Khorangah, B. Shokri, Comparison of Direct and Indirect cold atmospheric-pressure plasma methods in the B16F10 melanoma cancer cells treatment. *Sci. Rep.* **8**(1), 1–15 (2018). <https://doi.org/10.1038/s41598-018-25990-9>
28. S. Ikawa, K. Kitano, S. Hamaguchi, Effects of pH on bacterial inactivation in aqueous solutions due to low-temperature atmospheric pressure plasma application. *Plasma Process. Polym.* **7**(1), 33–42 (2010). <https://doi.org/10.1002/ppap.200900090>
29. S.M. Hosseini, B. Hosseinzadeh Samani, S. Rostami, Z. Lorigooini, Design and characterisation of jet cold atmospheric pressure plasma and its effect on *Escherichia coli* colour, pH, and bioactive compounds of sour cherry juice. *Int. J. Food Sci. Technol.* **56**(10), 4883–4892 (2021). <https://doi.org/10.1111/ijfs.15220>
30. V.S.S.K. Kondeti et al., Long-lived and short-lived reactive species produced by a cold atmospheric pressure plasma jet for the inactivation of *Pseudomonas aeruginosa* and *Staphylococcus aureus*. *Free Radic. Biol. Med.* **124**, 275–287 (2018). <https://doi.org/10.1016/j.freeradbiomed.2018.05.083>
31. A.L.V. Cubas et al., Effect of chemical species generated by different geometries of air and argon non-thermal plasma reactors on bacteria inactivation in water. *Sep. Purif. Technol.* **222**, 68–74 (2019). <https://doi.org/10.1016/j.seppur.2019.03.057>
32. P. Lukes, M. Clupek, V. Babicky, B. Pongrac, M. Simek, Bulk-phase chemistry induced by nanosecond discharge plasma in water. In: 2017 IEEE 19th International Conference on Dielectric Liquids (ICDL), (2017), pp. 1–3, <https://doi.org/10.1109/ICDL.2017.8124702>
33. Y.S. Seo, A.A.H. Mohamed, K.C. Woo, H.W. Lee, J.K. Lee, K.T. Kim, Comparative studies of atmospheric pressure plasma characteristics between He and Ar working gases for sterilization. *IEEE Trans. Plasma Sci.* **38**(10 PART 2), 2954–2962 (2010). <https://doi.org/10.1109/TPS.2010.2058870>
34. E. Ilik, T. Akan, Optical properties of the atmospheric pressure helium plasma jet generated by alternative current (a.c.) power supply. *Phys. Plasmas* (2016). <https://doi.org/10.1063/1.4948718>
35. A.N. Korbut, V.A. Kelman, Y.V. Zhmenyak, M.S. Klenovskii, Emission properties of an atmospheric-pressure helium plasma jet generated by a barrier discharge. *Opt. Spectrosc. (English Transl. Opt. i Spektrosk.)* **116**(6), 919–925 (2014). <https://doi.org/10.1134/S0030400X14040146>
36. J.J. Camacho, J.M.L. Poyato, L. Díaz, M. Santos, Optical emission studies of nitrogen plasma generated by IR CO2 laser pulses. *J. Phys. B At. Mol. Opt. Phys.* **40**(24), 4573–4590 (2007). <https://doi.org/10.1088/0953-4075/40/24/003>
37. S.J. Strickler, The identification of molecular spectra (Pearse, R. W. B.; Gaydon, A. G.). *J. Chem. Educ.* **41**(5), A398 (1964). <https://doi.org/10.1021/ed041pA398>
38. T. Darny, J.M. Pouvesle, J. Fontane, L. Joly, S. Dozias, E. Robert, Plasma action on helium flow in cold atmospheric pressure plasma jet experiments. *Plasma Sources Sci. Technol.* (2017). <https://doi.org/10.1088/1361-6595/aa8877>
39. M. Foletto, V. Puech, J. Fontane, L. Joly, L.C. Pitchford, Evidence of the influence of plasma jets on a helium flow into open air. *IEEE Trans. Plasma Sci.* **42**(10), 2436–2437 (2014). <https://doi.org/10.1109/TPS.2014.2331393>
40. R. Zaplotnik, M. Bišćan, Z. Kregar, U. Cvelbar, M. Mozetič, S. Milošević, Influence of a sample surface on single electrode atmospheric plasma jet parameters. *Spectrochim. Acta Part B At. Spectrosc.* **103–104**, 124–130 (2015). <https://doi.org/10.1016/j.sab.2014.12.004>
41. P.J. Bruggeman et al., Plasma-liquid interactions: a review and roadmap. *Plasma Sources Sci. Technol.* (2016). <https://doi.org/10.1088/0963-0252/25/5/053002>
42. Q. Xiong et al., Temporal and spatial resolved optical emission behaviors of a cold atmospheric pressure plasma jet. *J. Appl. Phys.* (2009). <https://doi.org/10.1063/1.3239512>
43. G. Nersisyan, T. Morrow, W.G. Graham, Measurements of helium metastable density in an atmospheric pressure glow discharge. *Appl. Phys. Lett.* **85**(9), 1487–1489 (2004). <https://doi.org/10.1063/1.1784514>
44. G.V. Naidis, Production of active species in cold helium-air plasma jets. *Plasma Sources Sci. Technol.* (2014). <https://doi.org/10.1088/0963-0252/23/6/065014>
45. R. Ono, Optical diagnostics of reactive species in atmospheric-pressure nonthermal plasma. *J. Phys. D Appl. Phys.* (2016). <https://doi.org/10.1088/0022-3727/49/8/083001>

PAPER • OPEN ACCESS

Radial profile of the electron energy distribution function in RF capacitive gas-discharge plasma

To cite this article: M Dimitrova *et al* 2016 *J. Phys.: Conf. Ser.* **700** 012007

View the [article online](#) for updates and enhancements.

Related content

- [Modernization of the X-Ray Tomographic Scanner Based on Gas-Discharge Linear Detector](#)
S G Stuchebrov, A V Batranin and I A Miloichikova
- [Evaluation of the sensitivity of the gas-discharge gamma-counters to the concomitant neutron radiation](#)
G L Pikalov and S V Kiseev
- [Theoretical study of thermal conductivities of various gas mixtures through the generalized Lennard-Jones interaction potential for application in gas-discharge lasers](#)
K A Temelkov, S I Slaveeva and Yu I Fedchenko

Radial profile of the electron energy distribution function in RF capacitive gas-discharge plasma

M Dimitrova^{1,5}, Tsv Popov², N Puac³, N Skoro³, K Spasic³, G Malovic³,
F M Dias⁴ and Z Lj Petrovic³

¹Acad. E. Djakov Institute of Electronics, Bulgarian Academy of Sciences,
72 Tzarigradsko Chaussee, 1784 Sofia, Bulgaria

²Faculty of Physics, St. Kl. Ohridski University of Sofia,
5 J. Bourchier blvd. 1164 Sofia, Bulgaria

³Institute of Physics, University of Belgrade, 118 Pregrevica, 11080 Belgrade, Serbia

⁴Instituto de Plasmas e Fusão Nuclear, Instituto Superior Técnico,
Universidade de Lisboa, 1049-001 Lisboa, Portugal

E-mail: miglena.dimitrova@gmail.com

Abstract. This paper reports experimental results on low-pressure argon capacitive RF discharge (parallel-plate capacitively-coupled plasma – CCP) under different conditions, namely, gas pressure in the range $3 \div 30$ Pa and RF power in the range $10 \div 100$ W. The IV characteristics measured were processed by two different second-derivative probe techniques for determination of the plasma parameters and the electron energy distribution function. The radial profiles of the main plasma parameters are presented.

1. Introduction

Low-temperature (non-equilibrium) plasmas are the basis of a number of technologies, old, current and future. The success story is, of course, plasma etching, which, together with photo-lithography, is the basis for miniaturization of integrated circuits; other major applications include surface alloying, thin-film deposition, plasma displays, modification of the properties of polymers and organic materials. Recently, the most promising has seemed to be the field of plasma-based medical applications. However, non-equilibrium plasmas are difficult to describe by universal theories, so that joint efforts are needed in diagnostics and modelling in order to understand their properties and use that knowledge to control, design and optimize applications. The importance of the research is that it will facilitate applications while focusing the scientific effort on the fundamental aspects of non-equilibrium plasmas [1]. Joint experimental and modelling efforts are required to make any general, fundamental conclusions about non-equilibrium plasmas.

This paper reports experimental results on studying a capacitive low-pressure argon RF discharge for a range of conditions [2], such as gas pressure in the range $3 \div 30$ Pa and power ranging from 10 W to 100 W. The current-voltage (IV) characteristics obtained by a Langmuir probe were processed by two different second-derivative probe techniques [3] to determine the plasma parameters and the

⁵ To whom any correspondence should be addressed.



electron energy distribution function (EEDF). The radial profiles of the main plasma parameters were also constructed.

2. Langmuir probe measurements in a RF capacitively coupled system

The RF system consisted of a chamber with parallel plate electrodes powered by a RF source with a driving frequency $f = 13.56$ MHz. The discharge in this experiment was ignited at an electrode distance of 0.07 m between the top powered and the bottom grounded electrode both with a diameter of 0.11 m. The transmitted RF power was measured at the source and always stayed below 1 % of transmitted power. A Hiden's ESPION Langmuir probe system with a motion stage was used to measure the IV characteristics. The probe tip with a diameter of 0.15 mm and a length of 10 mm was placed in the plasma with the motion stage allowing motion along the radial direction at $L = 0.02$ m above the bottom electrode. The IV characteristics' data were recorded using the ESPION software and then exported for further analysis.

In the "classical regime", which corresponds to our experimental conditions, the probe operates in the absence of a magnetic field and at low gas pressures in the range of 0.1 Pa to 100 Pa [4]. Then the electron probe current of the IV characteristic is expressed by the well-known formula [4]:

$$I_e(U) = -\frac{2\pi e S}{m^2} \int_{eU}^{\infty} (W - eU) f(W) dW, \quad (1)$$

where e and m are the electron charge and mass, S is the probe area, $W = \frac{1}{2}mc^2 + eU$ is the total electron energy in the probe sheath and c is the electron velocity. Here the probe is negatively biased by a potential U_p and U is the probe potential with respect to the plasma potential U_{pl} ($U = U_p - U_{pl}$). $f(\varepsilon)$ is the isotropic electron energy probability function (EEPF) [1], normalized by:

$$\frac{4\pi\sqrt{2}}{m^{3/2}} \int_0^{\infty} f(W)\sqrt{W} dW = \int_0^{\infty} f(\varepsilon)\sqrt{\varepsilon} d\varepsilon = n. \quad (2)$$

The EEPF can be determined by using the Druyvesteyn's formula [5]:

$$f(\varepsilon) = \frac{2\sqrt{2m}}{e^3 S} \frac{d^2 I_e(U)}{dU^2}. \quad (3)$$

The second derivatives obtained from the measured IV characteristics were evaluated by two techniques. The first one consists in adjacent averaging, smoothing and differentiating twice the measured IV characteristics. The instrumental function of the differentiation technique is triangular with a half-width equal to the step of change of the probe bias [6]. The other differentiating technique is based on the convolution of data with an adaptive, differentiating filter, whose instrumental function is automatically adjusted so that noise and distortion, i.e., error, are locally kept at about the same level. Details on how noise and distortion can be readily evaluated can be found in [3], as well as in the references therein. In this work, as before, we continue using $(1 + \cos(\dots))$ kind of filters for their flexibility on how the full-width-to-half-maximum (FWHM) can be adjusted to run-time, hence how readily the noise-to-error ratio can be kept constant.

Figures 1 and 2 represent examples of the EEDFs evaluated at the center of the discharge chamber at 50 W discharge power and gas pressure of 6 Pa and 27 Pa. The solid black lines present results from direct differentiation. The distortions between 0 and 10 eV cannot be explained by the influence of the differentiation method's instrumental function and the probe size [6]. A possible reason of the appearance of additional distortions is the insufficient ratio Σ between the surface area of the measuring (S_p) and reference (S_r) probes of the HIDDEN probe circuit. Usually, it is accepted that it has to be:

$$\Sigma = \frac{S_r}{S_p} > \sqrt{\frac{M}{m}}. \quad (4)$$

Here M is the ion mass. For precise measurements, a more severe criterion for the ratio Σ must be used [7]:

$$\Sigma = \frac{S_r n_r (T_r)^{1/2}}{S_p n_p (T_p)^{1/2}} G_\alpha \geq 10^4. \quad (5)$$

In this equation, T and n are the electron temperatures and densities at the positions of the measuring (p) and reference (r) probes. The factor G_α is tabulated in [7] for different probe and reference probe geometries.

On the other hand, the reference probe is flush mounted on the probe holder (close to the probe tip) with surface area not enough to satisfy the condition (5). To compensate for the insufficient ratio Σ in the second technique, an effective resistance R_{eff} was added to the probe circuit. Results with $R_{eff} = 200\Omega$ (red curve) and $R_{eff} = 500\Omega$ (blue curve) are presented in figure 1. As the effective resistance R_{eff} is increased, the EEDF evaluated approaches the Maxwellian with an electron temperature of 5 eV up to the energy of the first excited level of argon (11.56 eV). At higher energies, the EEDF deviates from Maxwellian due to the inelastic electron-atom collisions and the non-equilibrium nature of the discharge. We should point out that the distortions of the blue curve in the range $0 \div 3.5$ eV correspond to the distortions due to the instrumental function and the influence of the probe size [6].

The same considerations are related to the results recorded at a higher pressure presented in figure 2. Here, the effective resistances are $R_{eff} = 2k\Omega$ (red curve) and $R_{eff} = 5k\Omega$ (blue curve). It can be seen that the blue curve is not appropriate. The electron temperature in this regime of the discharge is 6 eV.

We have to point out that to solve the problem mentioned above, additional experiments with different reference probe areas are planned for the near future.

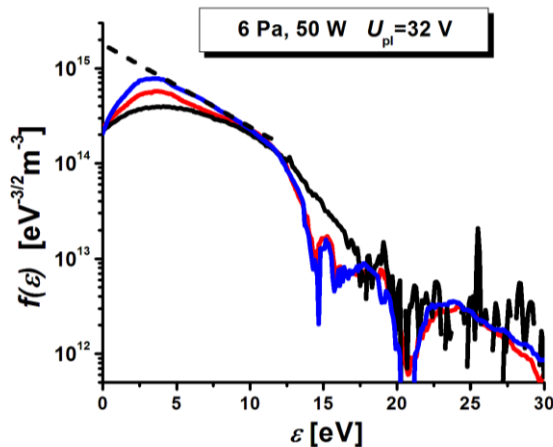

Figure 1. EEPF obtained by direct differentiation of the measured IV (solid black line); red curve – obtained by introducing a 200Ω effective resistance in the probe circuit; and the blue curve, 500Ω .

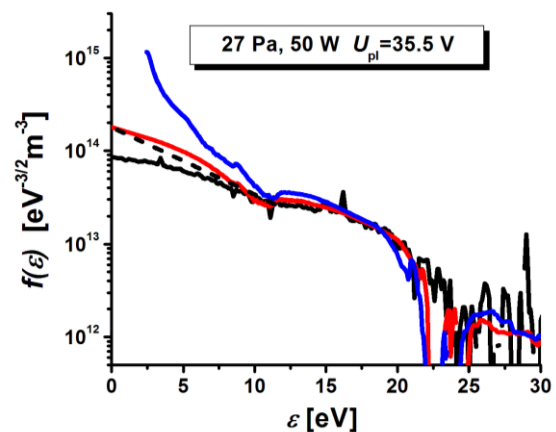

Figure 2. EEPF obtained by direct differentiation of the measured IV (solid black line); red curve – obtained by introducing a $2k\Omega$ effective resistance in the probe circuit; and the blue curve, $5k\Omega$.

3. Experimental results

Below we present the main plasma parameters evaluated from the IV characteristics measured at different radial positions. The radial distributions of the plasma potential at different discharge RF power values and different gas pressures are presented in figures 3 a) and 3 b). The accuracy of the evaluation is $\sim 10\%$. In figure 3, the U_{pl} is higher at the center of the discharge. This effect is more pronounced at higher gas pressures (figure 3 b)). At lower pressures, the U_{pl} is almost constant. The dashed lines indicate the size of the electrodes. As the discharge power is increased, the plasma potential values increase by about 10 V.

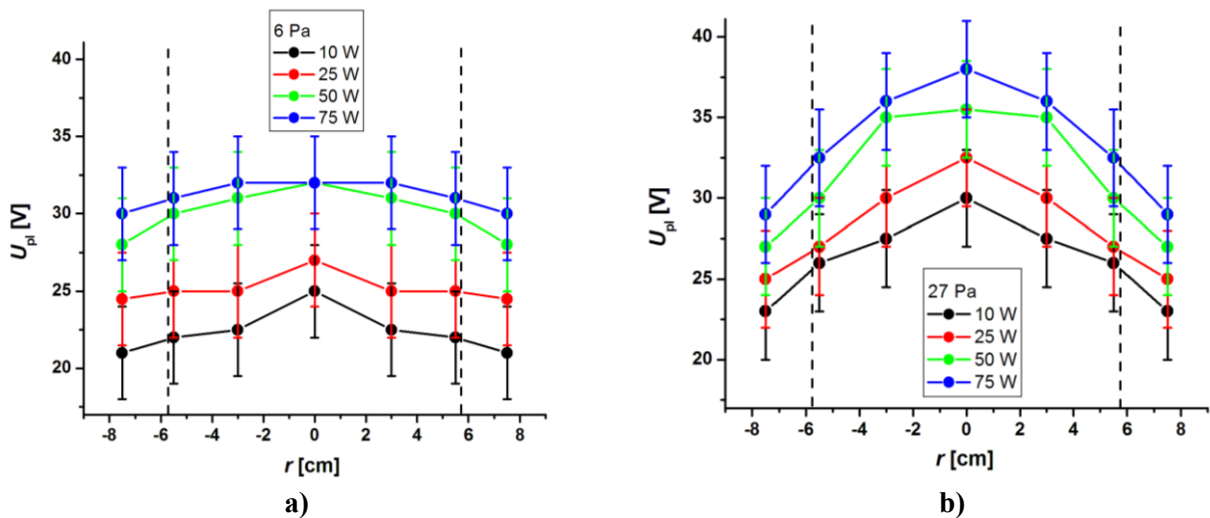

Figure 3. Radial distributions of the plasma potential at different discharge RF power values and different gas pressures.

As we mentioned, the EEPF can be approximated by a Maxwellian distribution up to the energy of the first excited level of argon. An example of the resulting electron temperatures are presented in figure 4 a), b).

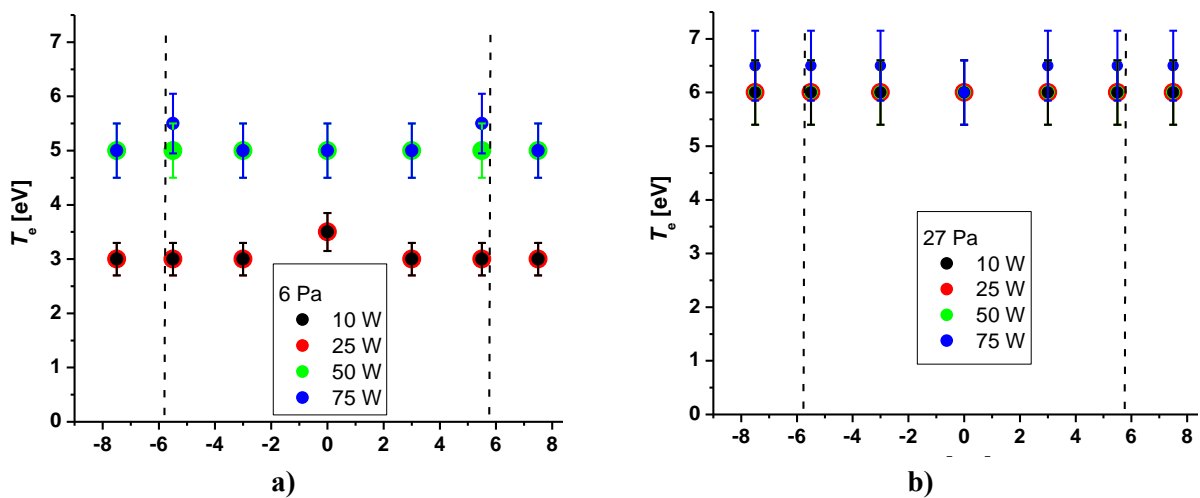

Figure 4. Radial distributions of the electron temperatures at different discharge RF power values and different gas pressures.

Figure 5 shows the corresponding radial profiles of the electron densities at different discharge RF power values and different gas pressures.

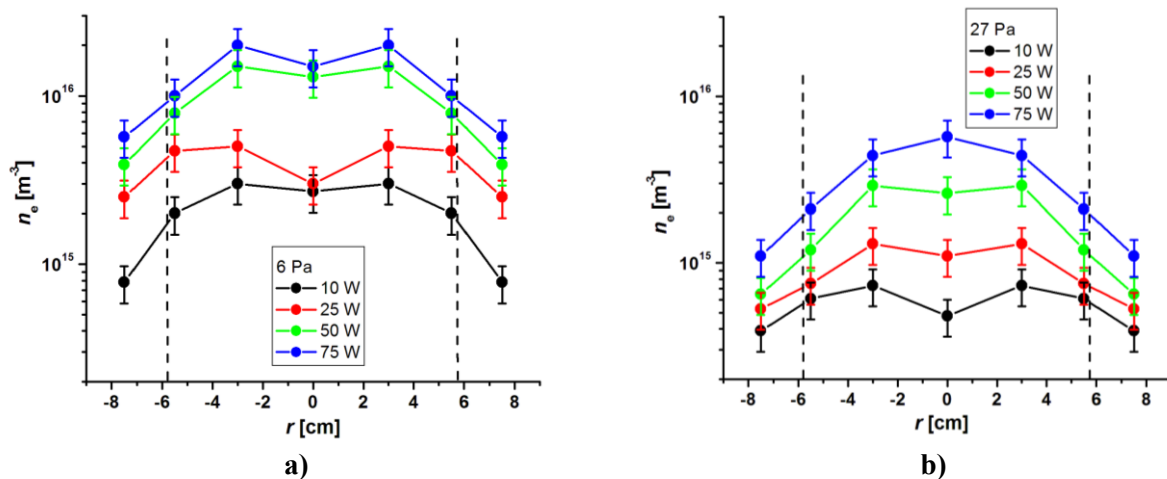

Figure 5. Radial distributions of the electron densities at different discharge RF power values and different gas pressures.

4. Conclusions

This paper reports experimental results on a capacitive low-pressure argon RF discharge at different conditions, as gas pressure in the range 3 ÷ 30 Pa and RF power within 10 ÷ 100 W.

The current-voltage (I - V) characteristics measured were processed by two different second derivative probe techniques for determination of the plasma parameters and the electron energy distribution function (EEDF). The radial profiles of the plasma potential and the electron temperatures and densities at different discharge RF powers and different gas pressures are presented.

Acknowledgements

This research has been supported by the JOINT RESEARCH PROJECTS between the Academy of Sciences and Arts of Serbia (SASA) and the Institute of Electronics BAS BG, and the Portuguese FCT – Fundação para a Ciência e Tecnologia, under Project UID/FIS/50010/2013. Additional funding for experiment is provided by SASA project 155 and MPNTR of Serbia ON171037 and III41011.

References

- [1] Godyak V A and Demidov V I 2011 *J. Phys. D: Appl. Phys.* **44** 233001
- [2] Godyak V A, Piejak R B and Alexandrovich B M 1992 *Plasma Sources Sci. Technol.* **1** 36-58
- [3] Dias F M and Popov Tsv K 2007 *J. Phys.: Conf. Series* **63** 012005
- [4] Demidov V I, Kolokolov N B and Kudriavtsev A A 1996 *Probe Methods of Diagnostics of Low Temperature Plasma* (Moscow: Energoatomizdat) (in Russian)
- [5] Druyvesteyn M J 1930 *Z. Phys.* **64** 781-98
- [6] Popov Tsv K, Dimitrova M, Dias F M, Tsaneva V N, Stelmashenko N A, Blamire M G and Barber Z H 2006 *J. Phys.: Conf. Series* **44** 60-9
- [7] Chang J-S 1973 *J. Phys. D: Appl. Phys.* **6** 1674

Development of Biomedical Applications of Non-equilibrium Plasmas and Possibilities for Atmospheric Pressure Nanotechnology Applications

Z.Lj. Petrović, N. Puač, D. Marić, D. Maletić, K. Spasić, N. Škoro,
J. Sivoš, S. Lazović, G. Malović

Abstract - In this paper we discuss the synergisms between different realms of plasma supported nanotechnologies. First the developments in plasma etching for micro and later nanoelectronics have fueled immense growth of knowledge and tools in describing non-equilibrium plasmas. This has led to detailed predictive codes and that knowledge has been used to develop a large number of new sources of non-equilibrium plasmas operating at atmospheric pressure, even in air. With those tools a new front of plasma medicine has opened wide with new possibilities and a number of promising techniques for sterilization, cancer treatment, oral cavity treatment, dermatology and in a range of applications where deposition of thin films for biocompatibility is necessary. This new front opens new possibilities in the realm of nanotechnologies with atmospheric pressure deposition of nano-structures allowing direct application of new techniques in medicine and in cheaper technologies for other purposes.

I. INTRODUCTION

Non-equilibrium plasma etching and related plasma processes [1] have proven to be the key to achieving manufacturing of integrated circuits, adherence to Moore's law and fueling of the global economy through explosion of all fields of economy that may benefit or even be generated with a strong dependence on processing power. The most important steps in developing of modern micro-electronic technology were achieved by empirical industry based research and science came in later to explain. Having said that, we must acknowledge a lot of successes in continuous improvements of the technology that were made, based on scientific development of diagnostics, modeling and fine tuning of key steps, such as multi frequency [2] and pulsed operation [3]. Finally science has made a significant contribution to understanding and

Z.Lj. Petrović, N. Puač, D. Marić, D. Maletić, K. Spasić, N. Škoro, J. Sivoš, S. Lazović, G. Malović are with the Institute of Physics, University of Belgrade, Pregrevica 118, 11080 Belgrade, Serbia, E-mail: zoran@ipb.ac.rs

removal of defects caused by the plasma itself or by the ever increasing demands in miniaturization. The contribution of science nevertheless boils down mainly to BETTER UNDERSTANDING of non-equilibrium (low temperature, cold...) plasmas. Most directly this understanding spills over to predictive models [1,4,5] that have been developed for complex geometries, complex chemistries and powering sequences and may represent realistically most of the low pressure industry devices.

At the same time there are constant reminders from the cost aware practitioners that operation of plasma devices is expensive, partly because of the need to have low pressure operation with vacuuming system to ensure the purity of gases. Operating pressures in industry are typically from few to 200 mTorr and purity of the gas that has to be achieved requires pumping down to very low pressures before the gas flow is started. Thus plasma devices operating at atmospheric pressure have been the holy grail of the industry, although some processes are not much cheaper and also cleanliness of substrates may require operation in pure gases maintained in sealed vacuum tight systems (albeit with somewhat smaller restrictions on pumping). Finally vacuum systems make production line manufacturing more complicated. In any case high pressure operation of plasma devices would be a welcome addition to the existing battery of plasma devices that micro-electronics industry has at its disposal.

Nano-particles worthy of scientific interest have been discovered first in atmospheric pressure thermal plasmas, but later non-equilibrium plasmas were shown to give some advantages and additional features [6,7]. While there are other processes that produce nano-particles, still one out of five significant papers in this field comes from the plasma background in one form or the other. Thus nanotechnologies are strongly connected to plasmas, especially non-equilibrium, and in all cases operation at atmospheric pressure would be beneficial.

Atmospheric pressure discharges and plasmas have been known in nature and have been generated by humans for the last 200 and more years. However, most of these plasmas are thermal which in principle means that electrons, ions and gas molecules tend to have the same temperature. When we calculate what is needed for ionization in order to maintain plasma, those are enormous temperatures. Yet maintaining plasma does not require all

free electrons to have excessive energies, only a small group in the high energy end of the distribution function needs to have such energies ($> 150\,000\text{ K}$), just enough to compensate the losses. Even such "reduced" requirement means that typical atmospheric pressure plasmas have a temperature of 5000 K - 10000 K . In that case, most of the energy invested into plasma goes to heating of gas and walls of the vessel. On the other hand such plasma is very productive, as every collision has a good chance to lead to dissociation needed to initiate chains of chemical reactions [8,9]. In any case, one cannot envisage application of a welding arc for treatment of organic materials or even treatment of living organisms. If applied for plasma etching, thermal plasmas would not provide selective anisotropic etching which is the foundation of our micro-electronics industry.

On the other hand, non-equilibrium plasmas have natural tendency to occur at low pressure, but they allow complete separation of electron kinetics from that of the ions and gas molecules [8]. This allows us to have the former at extremely high temperatures while the latter are essentially at the room temperature. Thus we may treat thermally unstable materials [10,11]. However there is no chance to apply such plasmas on living organisms, as pressures required for such plasmas do not allow living organisms to survive (with exception of some dry seeds and spores) [11,12].

Present is thus a very interesting time in plasma physics as, partly due to saturation of research motivated by micro electronics industry (read draining of the funds), a new front of applications is being developed. This time it is the science that leads the way, fueled by the achievements of the previous period and supported by a promise of significant discoveries albeit in completely different fields [13-17]. Plasma scientists have almost single-mindedly focused on developing new and more practical plasma sources operating at atmospheric pressure and mainly in atmospheric gases [16,17]. At the same time, new fronts of applications open and also the new possibilities in the existing fronts.

First of the two most important motivations stem from a broad range of different, completely different in nature and in the required technology, applications associated with the nano-science (i.e. nanotechnologies). The second, the field of medical and biological (and biotechnical) applications has always been at a back of everybody's mind but little has been initiated from the plasma side. In this paper we shall discuss how motivation to develop new non-equilibrium plasma sources operating mainly in the air has propelled new application fronts in the medicine, biology and what it may offer to nanotechnologies. Finally we shall address possible connections and interdependencies between the two.

II. NON-EQUILIBRIUM PLASMAS AT LOW AND HIGH PRESSURES

Gas is ionized by applying an external source of energy, typically electric field (although often chemical or nuclear energy may do the trick). In external field a randomly produced electron will initiate an avalanche which may lead to the self sustained discharge and formation of plasmas if all conditions are met. Typically electrons cannot heat up the gas as their momentum transfer in collisions is small due to their low mass. When, however, charged particles have high density, the Coulomb force couples electrons and ions and through a continuous interaction (that may be described as a large number of momentum transfer collisions) ions get accelerated and they heat up the background gas.

At low pressures electrons have a relatively small number of collisions (proportional to the scaling parameter pd , where p is the pressure and d is the characteristic dimension along which field is effective). Electrons gain their energy based on the external field (normalized by the gas number density) E/N so that they may ionize (by a very small part of the ensemble from the high energy tail of the distribution) Thus if we plot the breakdown voltage V_B as a function of pd (Paschen curve) we have a minimum which gives the electrons, that have just the right number of collisions sufficient to maintain the discharge and the plasma. At lower pressures insufficient number of collisions requires a higher voltage and at higher pressures higher voltage is needed as, in spite of increased number of collisions at that particular E/N , the energy of electrons may not be sufficient to ionize.

Plasmas at atmospheric pressure have a tendency to have high densities of charged particles because, at such high pressure, every ionization avalanche produces very rapidly a large degree of ionization, changing completely the conditions and the field distribution. Usually those modes at higher degrees of ionization have more effective production and thus lower operating voltage and they take over above pressures of 100 Torr .

In Figure 1 we show Paschen curve [18] for the breakdown in water vapour. At the upper right end, conditions have been met for a streamer breakdown, which first requires a Townsend like avalanche, but then it has a lower breakdown voltage and dominates the breakdown at higher pressures, including the atmospheric pressure. Breakdown of water is of interest for both, plasma medical applications but also for special treatment of organic materials and related modeling of discharges in realistic atmospheric gas mixtures.

Streamers have sufficient density of charged particles to turn off the external field in its center completely and the ionization is due to the extremely high fields at the plasma edges due to separation of ions and electrons. Photo ionization is supporting the development under some conditions. The plasma channel that develops is highly conductive and once it connects two electrodes large

current flows which again heats up the gas further, heats the cathode and completely changes conditions.

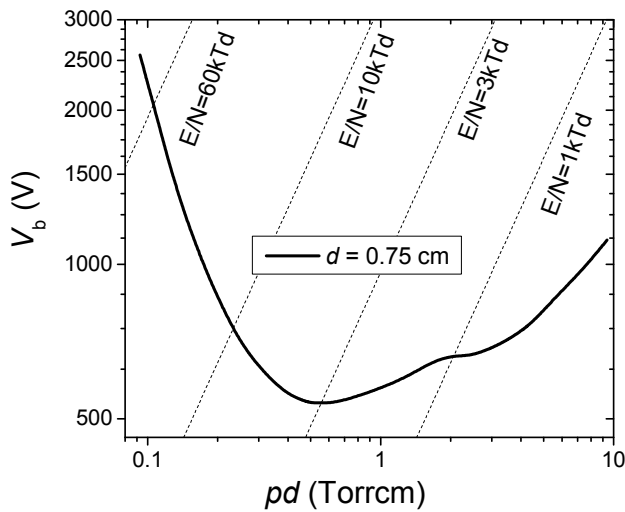

Fig. 1. Paschen curve for parallel plate discharge in water vapour, for standard gaps/pressures. At the right corner the breakdown by streamers is observed, limiting the ability to determine Paschen curve [18].

Even without developing a streamer, a standard non-equilibrium glow discharge first makes transition to the abnormal glow, where effects of excited molecules, heating of the gas and other effects become apparent and when surface of the cathode is heated sufficiently to produce new electrons more efficiently than the standard Townsend's mechanisms. Then, a transition is made to an arc plasma.

All efforts to create atmospheric pressure non-equilibrium plasmas are focused on controlling the excessive ionization growth. Following strategies may be employed:

A. Reduce the Distance

This in essence means that you may move the operating point to pd values that do not allow streamers but one needs also to limit the current by a resistor in the external circuit. Thus one may still operate close to the minimum of the Paschen curve [13,14,18].

This is the idea behind micro discharges, a fast growing field of plasma physics that is yet to show its full potential, although judging by Plasma TV cells it has already proved its value. Achieving desirable operation in micro discharges is not easy as the optimum distance for the atmospheric pressure would be around $12 \mu\text{m}$. Of course, one may pursue larger gaps of the order of $500 \mu\text{m}$, while still being in the optimum range and avoiding unwanted high ionization modes.

Apart from the difficulty to control and properly diagnose such discharges, one has to be aware of the new possible effects due to small distances, such as field emission and even quantum effects (e.g. tunneling) [19].

B. Reduce the Time

Reducing the time allowed to develop the ionization is also a possibility that has been shown to work either on its own (capacitively coupled atmospheric pressure discharge) or in combination with other techniques. Turning the field on and off or using a more practical approach of using RF fields, in both cases give a possibility to use scaling with time ω/N to control ionization. One however enters a different realm of physics, such as RF breakdown, which has its own characteristics and also an option to achieve breakdown without production of secondary electrons at surfaces, (i.e. without electrodes) [20,21].

C. Inhomogeneous Field

The non-equilibrium plasma that has always been present in human experience is corona which is often observed in different forms (St. Elmo's fire). It is formed around a sharp peak or a wire, where field is very inhomogeneous. Thus ionization occurs over a limited gap and, at the same time, a low field is maintained elsewhere to carry the charges and close the current loop. Corona has been discharging our capacitors and all charged objects but has also found a lot of applications, including the purification of air and ion wind which, while potentially useful, is often observed as a kind of a circus attraction.

Normally around the sharp peak a discharge develops (see Figure 2) which is in its properties very much like swarms or Townsend's discharges. It is too weakly ionized to be regarded a plasma. However, often streamers are formed randomly and they consist of real plasma. Both parts of the discharge may be useful in producing charged particles and active species.

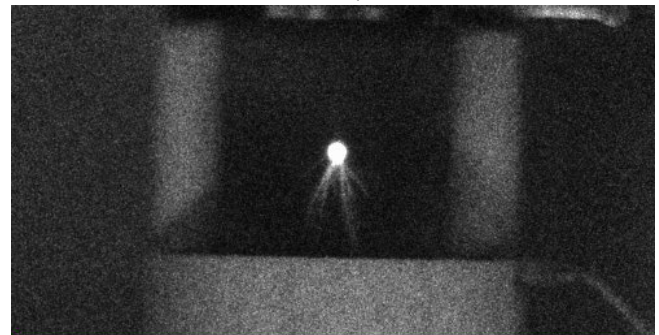

Fig. 2. A point to plane corona discharge developed for sterilization of air.

D. Block the Discharge

The technique employed in the so called Dielectric Barrier Discharges (DBD) is to cover one or both electrodes by a dielectric. Thus, when discharge arrives at the surface, it deposits its charge there and shields the electric field, thereby stopping the discharge altogether. This discharge has been shown to operate in other modes as well, glow and filamentary depending on the conditions.

E. Reduce the Breakdown Voltage

Part of the problem in the air is that it contains oxygen, a very electronegative gas that attaches electrons both at low and moderate energies. This increases the breakdown voltage and the discharge operates at high E/N that is prone to fast ionization. When breakdown occurs, it is when ionization overcomes attachment (and other) losses and under such conditions production of electrons can be very fast and lead to sparks, streamers and transition to the arc. The rare gases have lower breakdown voltage as they have no attachment. At the same time, they have no inelastic processes at lower energies and electrons get easily heated to high energies, where they lose energy in electronic excitation. Typically molecular gases present in the air have a lower ionization potential than argon or helium and thus one benefits from starting a discharge in the rare gas and then to mix it with the air [22,23].

F. Remote processing

It is also always possible to use the afterglow, the diffusion (and in some cases combined with flow) that brings active species from the discharge to the region of the treated sample [24]. Nevertheless, one has the same issues about producing and maintaining the plasma at the atmospheric pressure. While this works for deposition of thin films it is of limited use for plasma medical applications except in the case of sterilization.

G. Available plasma Sources for Atmospheric Pressures

In addition to earlier mentioned sources, most other sources apply several principles at the same time. Atmospheric pressure plasma jets and plasma needle use this principle combined with temporal modulation (which is more important for the plasma needle that achieves lower breakdown voltages by operating at RF frequency). In those sources discharge is produced in rare gas and it extends to the region where it is mixed with the air thus producing active radicals. Microwave sources often have spatial limitation in addition to temporal modulation, but also often are used through their afterglow.

In general, atmospheric pressure non-equilibrium discharges are often smaller than desirable, may require additional flow of rare gases and may have higher breakdown voltages and likelihood of sparks than low pressure discharges. Still they produce the same effects as the low pressure discharges; most importantly they produce chemically active plasma without heating of the gas.

Finally a note, even if a discharge operates at atmospheric pressure but in a rare gas for example, the procedure still requires a vacuum tight vessel and also techniques to pass the production line through that. Thus if a low pressure is an option at all, it should be exercised. For example, passage of samples through vacuum

chambers has been made extremely efficient in case of plasma nitriding of steel sheaths or treatment of cling foils. However once we developed atmospheric pressure non-equilibrium plasmas, new possibilities of application open and those will be discussed later in this paper.

III. NEW RESULTS WITH ATMOSPHERIC PRESSURE PLASMA JET

One of the atmospheric pressure plasma sources has yielded a lot of new, unforeseen effects that warranted detailed, still incomplete, fundamental studies. This source consists of a glass tube which in one end is connected to the source of a rare gas helium (usually). At the other end it is open to the atmosphere and gas flows freely into the air. Close to the open end is a pair of electrodes that have to have sufficient length and gap between them. When a low frequency RF is applied, a plume of plasma is produced that is 5-10 cm in length, that is a non-equilibrium plasma and that, more often than not, actually consists of small plasma bullets passing through the air, i.e. outside the field applied to form the plasma, very rapidly, much faster than the flow of air [25-27]. Voltages required to achieve plasma for APPJ are typically several kV while frequencies vary from 30 kHz to 250 kHz.

The bullets were "shot" towards the air and never against the flow towards the source of gas. On the other hand, it was often found that the bullet's appearance coincided with the establishment of the discharge at the electrode opposite to the exit from the tube, something that could not be easily explained.

In order to follow this phenomenon at all times we have applied transparent electrodes made of Indium Tin Oxide. The observed development of the plasma is shown in Figure 3.

The results show that there is a full continuity of plasma which is formed at the electrode closer to the edge (when it is instantaneous cathode). The discharge expands towards the anode but at the same time hollow cathode like plasma travels along the electrode. It has a circular shape and is close to the walls. When it leaves the electrode plasma reforms at the axis of the tube and proceeds to the edge. Only at the edge a plasma bullet is formed, a much brighter, well defined plasma that begins to move with speed up to 20 km/s which is five time faster than the speed inside the electrode. The coincidence of appearance of the bullet at the same time when plasma develops at the further electrode is due to a slower motion of plasma inside the electrode and tube. Clearly further diagnostics and modeling are required to fully understand the formation and development of plasma bullets, although the first results seem to associate it with the streamers.

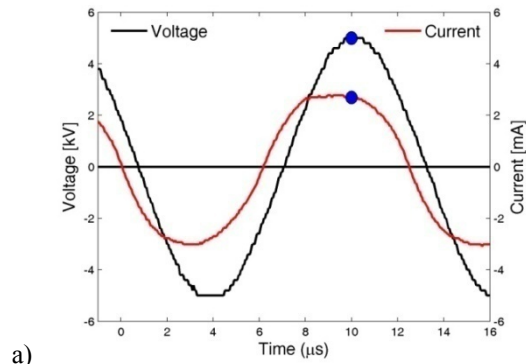

a)

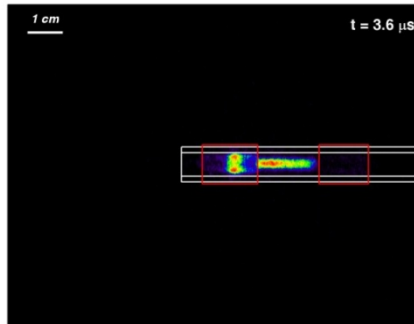

b)



c)

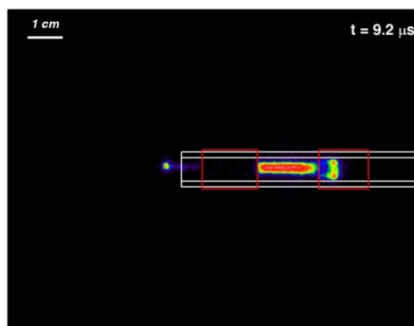

d)

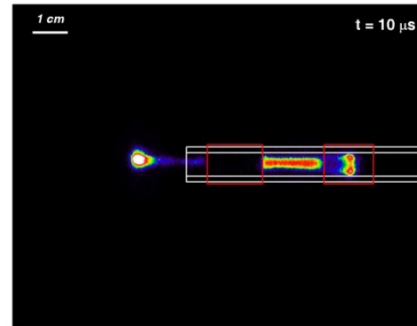

e)

Fig. 3. Development of voltage and current waveforms, the current shows conductive part in phase with the voltage (a) and motion of plasma between two electrodes and inside the powered (closer to the edge of the tube) (b-c), formation of the plasma bullet (d) and its motion outside the tube (e) [28].

IV. PLASMA MEDICINE

In addition to its interesting basic physics APPJ has a potential for medical applications [29]. The field of plasma medicine has exploded in the last 10 years from a trickle to hundreds of publications per year. Number of new group and new directions is also breathtaking. As mentioned above the whole field is fueled by the fundamental advances in development of atmospheric pressure plasmas sources, that have been founded on the knowledge on non-equilibrium plasmas developed for the previous round of applications in micro electronics. We will leave a comprehensive literature review for a later publication as this one does not allow enough space.

The first well established application was in sterilization i.e. in destruction of micro organisms. In addition to bacteria [12,29,30], plasmas are equally efficient in removing spores, fungi, viruses and prions. Results of sterilization by using plasma needle of planktonic samples containing 4 different concentrations of *S. aureus* are shown in Figure 4. Also, no form of resistance has been observed. Sterilization may be applied to medical equipment or environment in contact with patients (e.g. surgical equipment, catheters, purification of air, ...). Plasma sterilization is the only technique to remove antibiotic resistant bacteria. One should also be aware that this type of sterilization is quite different from plasma assisted H_2O_2 sterilization where plasma has a secondary role in removing some of the toxic products.

The sterilization has also another important aspect. It has been show that the effect on human cells is much more modest. One can speak of distinct selectivity. This aspect allows application of plasmas for in vivo sterilization, i.e. to treatment of wounds.



Fig. 4. Planktonic samples of *S. aureus* treated by plasma and afterwards cultivated on growth medium. Flow of He was 1 slm and the power was 1.6 W. Four different initial concentrations of bacteria were used: (1) $12 \cdot 10^8$ CFU/ml; (2) $12 \cdot 10^7$ CFU/ml; (3) $12 \cdot 10^6$ CFU/ml; (4) $12 \cdot 10^5$ CFU/ml.

Wound treatment also has other aspects like a much (40 times) faster blood coagulation. This property is already used in surgery to close the bleeding from blood vessels. Plasma treatment has been shown to be very effective in treatment of wounds, even chronic wounds like those associated with the diabetes. Some of the diseases have been shown to be completely cured (in dermatology), for some standard treatment is facilitated and success rate increased.

A significant success has been achieved in applying plasma to the oral cavity. First it was shown that plasma may remove anaerobic bacteria that lead to the tooth decay without drilling of the healthy tissue. Later it was shown that sterilization of the root canal is very effective and so is fighting against plaque [12] and even ulcers. Finally plasma was shown to be an effective tool for bleaching.

In addition to the oral ulcers, intestinal ulcers have also been successfully treated on laboratory animals. These treatments however require operation. The biggest goal and hope for plasma is the treatment of cancer. It is supported by the achievement of controlled plasma induced apoptosis of cells. These effects were shown again to be selective and affect cancer cells more than healthy cells. Cell cultures were shown to be removed efficiently, even grafted cancers on laboratory animals were shown to be significantly reduced, even cured. Currently the effect of plasma on cancer stem cells is studied with great hope of controlling the secondary tumors.

Surgical application of plasmas that are in non-equilibrium is also of considerable importance. A number of commercial products exist with potential for surgery with minimal blood loss, with the accuracy that rivals or exceeds that of laser surgery. Important advantage of plasma is that it generally leads to less necrosis of cells thus reducing the risks of inflammations. Several devices for specific applications are available including the tool for inducing plasmas in liquids for knee operations [31].

Surgical applications are not exhausted by surgical tools. One may use plasma for efficient tool sterilization and application of such systems to plastic tools extends their life due to reduced thermal strain. Even a hand

sterilizer has been developed that is effective in tens of seconds replacing minutes of scrubbing.

Medical applications have a much wider scope than direct use of plasmas directly on the tissue.

For example modeling of radiation damage due to electrons and positrons may be accomplished by the same tools used to model plasmas and following similar principles [32,33]. In fact models of electrons in liquids that are a good model of a tissue are akin to models of ionized gas albeit with slightly modified cross sections in order to take into account scattering of low energy particles on multiple targets.

Treatment of food may be regarded as a prevention, but the principles are the same, from sterilization of packaging to the actual sterilization of the meat or eggs.

Diagnostic tools based on plasmas include proton transfer mass spectroscopy that is able to detect volatile organic compounds in real time without dissociation (and resulting fragment analysis). Analysis of breath may give direct reading of disruptions of metabolism, effects of smoking and pollution, smoking and analysis of food may reduce chances of infection. Finally analysis of toxic fumes due to industrial accidents, war, fires or car accidents helps save humans from possible ill effects of pollutants. A similar method of analysis of fumes is based on Paschen curves [7] for different gases and operation of micro discharges.

Finally one should be aware that plasma may induce unwanted effects such as strand and double strand breaks in DNA [34] and possible toxicity of plasma treatment should be investigated vigorously though no effects have been reported so far.

V. POTENTIAL OF ATMOSPHERIC PRESSURE PLASMAS IN NANOTECHNOLOGIES AND RELATED APPLICATIONS IN MEDICINE

Plasma treatment of materials has a wide potential for applications in medicine. Reducing the hydrophobicity of polymer surfaces improves sampling in laboratory analysis. On the other hand, hyper hydrophobic surfaces are achieved by nanostructuring. The hydrophobic surface and such materials are difficult to soil and to provide basis for a spread of germs.

Biocompatible coatings are essential for a number of treatments. We would like to draw attention here to two applications. First is treatment of stents by biocompatible coatings, where one requires a micro discharge to deposit the material inside the stent [7].

Another related activity is functionalization of surfaces providing a basis for better adhesion of desired chemicals or particles. For example plasma treated textiles [10] allow binding of large numbers of nano-particles of silver or TO_2 that are bactericidal. Thus textile for surgeons, soldiers or people in food industry may be produced. Same is true for other surfaces and applications.

Functionalization of surfaces is a very wide spread technique in nanotechnologies. In addition to providing bonds between nanotubes or different weakly bound materials, functionalized surfaces may be activated to provide specific tasks. For example treatment of the substrate by plasma increases by a large factor (10 fold) the area of graphene samples produced by a sticky tape technique [35]. At the same time the graphene maybe subsequently coated by specific atoms or radicals using plasma. This would make it sensitive to different organic molecules and could be the basis of sensors, especially sensors for scanning of DNA [36].

By combining nanotechnology and medicine a quest is open for viable biocompatible sensors for human response and nanotubes are the front runners [37]. In that respect plasmas and especially low temperature plasmas may be the best option for growing arrays of nanotubes [38-40] that are coated and functionalized to reduce toxicity and favour certain applications.

Plasma enhanced chemical vapour deposition [PECVD] has been on the forefront of plasma applications in nano-technologies [38]. Mostly PECVD is done at low pressure plasmas and thermal atmospheric pressure plasmas (arcs) have been mostly confined to employing arcs. Applications for small size sensors and targeting of individual cells will require further development of non-equilibrium atmospheric pressure plasmas that would operate within the PECVD scheme or even in a broader context of plasmas used to grow nanotubes or other nano sized structures [41].

ACKNOWLEDGEMENT

This research has been supported by the MES Serbia, under projects ON171037 and III41011.

REFERENCES

- [1] T. Makabe, Z Lj Petrović, "Plasma Electronics: Application in Microelectronic Device Fabrication", *New York: Taylor and Francis*, 2006.
- [2] T. Kitajima, Y. Takeo, Z. Lj. Petrović, and T. Makabe, "Functional separation of biasing and sustaining voltages in two-frequency capacitively coupled plasma", *Applied Physics Letters*, vol. 77, no. 4, pp. 489-491, 2000.
- [3] M. Osiac, T. Schwarz-Selinger, D. O'Connell, B. Heil, Z. Lj. Petrović, M. M. Turner, T. Gans and U. Czarnetzki, "Plasma boundary sheath in the afterglow of a pulsed inductively coupled RF plasma" *Plasma Sources Sci. Technol.* vol. 16 pp. 355-363, 2007.
- [4] F. Hamaoka, T. Yagisawa, T. Makabe, "Modeling of Si Etching Under Effects of Plasma Molding in Two-Frequency Capacitively Coupled Plasma in SF₆/O₂ for MEMS Fabrication", *IEEE Transactions on Plasma Science*, vol. 35, pp. 1350-1358, 2007.
- [5] P. L. G. Ventzek, R. J. Hoekstra, M. J. Kushner, "Two-dimensional modeling of high plasma density inductively coupled sources for material processing", *J. Vac. Sci. Technol. B*, vol. 12, pp. 461-477, 1994.
- [6] K. H. Becker, K. H. Schoenbach, and J. G. Eden, "Microplasmas and applications", *J. Phys. D: Appl. Physics*, vol. 39, pp. R55-R70, 2006.
- [7] Z. Lj. Petrović, P. D. Maguire, M. Radmilović-Radenović, M. Radetić, N. Puač, D. Marić, C. Mahony, and G. Malović, "On Application of Plasmas in Nanotechnologies", in *Nanotechnology for Electronics, Photonics, and Renewable Energy*, A. Korin, P. S. Krstić and J. C. Wells, Eds., pp. 85-130, New York: Springer, 2010.
- [8] Z Lj Petrović, S Dujko, D Marić, G Malović, Ž Nikitović, O Šašić, J Jovanović, V Stojanović and M Radmilović-Radenović, "Measurement and interpretation of swarm parameters and their application in plasma modeling", *J. Phys. D: Appl. Phys.*, vol. 42, 194002 (33pp), 2009.
- [9] Z Lj Petrović, M Šuvakov, Ž Nikitović, S Dujko, O Šašić, J Jovanović, G Malović and V Stojanović, "Kinetic phenomena in charged particle transport in gases, swarm parameters and cross section data", *Plasma Sources Sci. Technol.*, vol.16, pp. S1-S12, 2007.
- [10] M. Gorenšek, M. Gorjanc, V. Bukošek, J. Kovač, Z. Lj. Petrović and N. Puač, "Functionalization of Polyester Fabric by Ar/N₂ Plasma and Silver" *Textile Research Journal*, vol. 80, no.16, pp.1633-1642, 2010.
- [11] N. Puač, Z. Lj. Petrović, S. Živković, Z. Giba, D. Grubišić and A. R. Đorđević, "Low temperature plasma treatment of dry Empress-tree seeds", *Plasma Processes and Polymers*, Eds. R. d'Agostino, P. Favia, C. Oehr and M.R. Wertheimer, Wiley, pp. 193-203, 2005.
- [12] S. Lazović, N. Puač, M. Miletić, D. Pavlica, M. Jovanović, D. Bugarski, S. Mojsilović, D. Maletić, G. Malović, P. Milenković, and Z. Lj. Petrović, "The effect of a plasma needle on bacteria in planktonic samples and on peripheral blood mesenchymal stem cells", *New J. Phys.*, vol. 12, 083037 (21pp), 2010.
- [13] D. Marić, N. Škoro, P. D. Maguire, C. M. O. Mahony, G. Malović, and Z. Lj. Petrović, "On the possibility of long path breakdown affecting the Paschen curves for microdischarges", accepted for publication in *Plasma Sources Sci. Technology*, 2012.
- [14] Z. Lj. Petrović, N. Škoro, D. Marić, C. M. O. Mahony, P. D. Maguire, M. Radmilović-Radenović, and G. Malović, "Breakdown, scaling and volt-ampere characteristics of low current micro-discharges", *J. Phys. D: Appl. Physics*, vol. 41, 194002 (5pp), 2008,.
- [15] F. Iza, A. Gon Jun Kim, A. Seung Min Lee, A. Jae Koo Lee, A. James L Walsh, A. Yuantao T. Zhang, and A. Michael G. Kong, "Microplasmas: Sources, particle kinetics, and biomedical applications", *Plasma Process. Polym.*, vol. 5, pp. 322-344, 2008.
- [16] T. Sato, T. Miyahara, A. Doi, S. Ochiai, T. Urayama, T. Nakatani, "Sterilization mechanism for Escherichia coli by plasma flow at atmospheric pressure", *Appl. Phys. Letters*, vol. 89, pp. 073902, 2006.
- [17] M. Laroussi, "Nonthermal Decontamination of Biological Media by Atmospheric-Pressure Plasmas: Review, Analysis, and Prospects", *IEEE Trans. Plasma Sci*, vol. 30, no. 4, 1409-1415, 2002.
- [18] N. Škoro, D. Marić, G. Malović, W. G. Graham, and Z. Lj. Petrović, "Electrical Breakdown in Water Vapor", *Phys. Rev. E*, vol. 84, 055401 (4pp), 2011.
- [19] M. Radmilović-Radenović and B. Radjenović, "Theoretical study of the electron field emission phenomena in the generation of a micrometer scale discharge" *Plasma Sources Sci. Technol.*, vol. 17, 024005 (5pp), 2008.

- [20] A. V. Lisovskiyy and V. D. Yegorenkov, "RF breakdown of low-pressure gas and a novel method for determination of electron-drift velocities in gases" *J. Phys. D: Appl. Phys.*, vol. 31, no. 23, pp. 3349–3357, 1998.
- [21] M. Savić, M. Radmilović-Radjenović, M. Šuvakov, S. Marjanović, D. Marić, Z. Lj. Petrović, "On Explanation of the Double-Valued Paschen-Like Curve for RF Breakdown in Argon", *IEEE Trans. Plasma Sci.*, vol. 39, no. 11, pp. 2556–2557, 2011.
- [22] E. A. Sosnin, E. Stoffels, M. V. Erofeev, I. E. Kieft, and S. E. Kunts, "The effects of UV irradiation and gas plasma treatment on living mammalian cells and bacteria: A comparative approach", *IEEE Trans. Plasma Sci.*, vol. 32, no. 4, pp. 1544–1550, 2004.
- [23] V. Schulz-von der Gathen, L. Schaper, N. Knake, S. Reuter, K. Niemi, T. Gans and J. Winter, "Spatially resolved diagnostics on a microscale atmospheric pressure plasma jet", *J. Phys. D: Appl. Phys.* vol. 41 pp.194004, 2008
- [24] K. Kutasi and J. Loureiro, "Role of the wall reactor material on the species density distributions in an N₂-O₂ post-discharge for plasma sterilization", *J. Phys. D: Appl. Phys.*, vol. 40, pp. 5612-5623, 2007.
- [25] J. Shi, F. Zhong, J. Zhang, D. W. Liu and M. G. Kong, "A hypersonic plasma bullet train traveling in an atmospheric dielectric-barrier discharge jet", *Phys. Plasmas*, vol. 15, no. 1, 013504 (5pp), 2008.
- [26] N. M. Bourdet, M. Laroussi, A. Begum and E. Karakas, "Experimental investigations of plasma bullets", *J. Phys. D: Appl. Phys.*, vol. 42, no. 5, 055207 (7pp) , 2009.
- [27] G. V. Naidis, "Simulation of streamers propagating along helium jets in ambient air: Polarity-induced effects", *Appl. Phys. Lett.*, vol. 98, no. 14, 141501(3pp), 2011.
- [28] N. Puač, D. Maletić, S. Lazović, G. Malović, A. Đorđević and Z. Lj. Petrović, "Time resolved ICCD images of an atmospheric pressure plasma jet with transparent electrodes" submitted 2012.
- [29] M. Laroussi, D. A. Mendis, and M. Rosenberg, "Plasma interaction with microbes", *New J. Phys.*, vol. 5, no. 1, pp. 41.1-41.10, 2003.
- [30] M. Laroussi, "Low Temperature Plasma-Based Sterilization: Overview and State-of-the-Art", *Plasma Process. Polym.*, vol. 2, pp. 391-400, 2005.
- [31] K. R. Stalder, G. Nersisyan, and W. G. Graham, "Spatial and temporal variation of repetitive plasma discharges in saline solutions", *J. Phys. D: Appl. Physics*, vol. 39, pp. 3457–3460, 2006.
- [32] A. Banković, S. Dujko, R. D. White, J. P. Marler, S. J. Buckman, S. Marjanović, G. Malović, G. Garcia and Z. Lj. Petrović, "Positron transport in water vapour" *New Journal of Physics*, vol. 14, 035003 (23pp), 2012.
- [33] G. Garcia, Z. Lj. Petrović, R. White, S. Buckman "Monte Carlo Model of Positron Transport in Water: Track Structures Based on Atomic and Molecular Scattering Data for Positrons" *IEEE Trans. Plasma Sci.*, vol. 39, pp. 2962 - 2963, 2011.
- [34] D. O'Connell, L. J. Cox, W. B. Hyland, S. J. McMahon, S. Reuter, W. G. Graham, T. Gans, and F. J. Currell "Cold atmospheric pressure plasma jet interactions with plasmid DNA". *Appl. Phys. Lett.*, vol. 98, pp.043701, 2011.
- [35] G. Isić, M. Jakovljević, M. Filipović, D. Jovanović, B. Vasić, S. Lazović, N. Puač, Z. Lj. Petrović, R. Kostić, R. Gajić, J. Humliček, M. Losurdo, G. Bruno, I. Bergmair, and K. Hingerl, "Spectroscopic Ellipsometry of Few-Layer Graphene", *J. Nanophoton.*, vol. 5, pp.051809, 2011.
- [36] S. Joseph, W. Guan, M. A. Reed, and P. S. Krstic, "A long DNA segment in a linear nanoscale Paul trap", *Nanotechnology*, vol. 21, pp. 015103 (10pp), 2010.
- [37] K. Balasubramanian, M. Burghard, "Biosensors based on carbon nanotubes", *Anal. Bioanal. Chem.*, vol. 385, no. 3, pp. 452-468, 2006.
- [38] M. Meyyappan, L. Delzeit, A. Cassell and D. Hash, "Carbon nanotube growth by PECVD: a review", *Plasma Sources Sci. Technol.*, vol. 12, pp. 205–216, 2003.
- [39] B. K. Kenneth Teo, D. B. Hash, R. G. Lacerda, N. L. Rupesinghe, M. S. Bell, S. H. Dalal, D. Bose, T. R. Govindan, B. A. Cruden, M. Chhowalla, G. A. J. Amaratunga, M. Meyyappan and W. I. Milne, "The Significance of Plasma Heating in Carbon Nanotube and Nanofiber Growth", *Nano Letters*, vol. 4, no. 5, pp. 921-926, 2004.
- [40] M. Meyyappan, "Carbon Nanotubes: Science and Applications", New York CRC Press 2004.
- [41] K. Ostrikov, U. Cvelbar and A. B. Murphy, "Plasma nanoscience: setting directions, tackling grand challenges", *J. Phys. D: Appl. Phys.*, vol.44, 174001 (29 pp), 2011.

See discussions, stats, and author profiles for this publication at: <https://www.researchgate.net/publication/268437643>

Spatial profiles of atomic oxygen concentrations in a large scale CCP reactor

Article

CITATIONS

0

READS

27

7 authors, including:



Saša Lazović

Institute of Physics Belgrade

90 PUBLICATIONS 695 CITATIONS

[SEE PROFILE](#)



Kosta Spasic

University of Belgrade

17 PUBLICATIONS 85 CITATIONS

[SEE PROFILE](#)



Nevena Puač

Institute of Physics Belgrade

124 PUBLICATIONS 1,260 CITATIONS

[SEE PROFILE](#)



Gordana Malovic

Institute of Physics Belgrade

172 PUBLICATIONS 1,852 CITATIONS

[SEE PROFILE](#)

Some of the authors of this publication are also working on these related projects:



PlasmaTex - plasma for antibacterial textile materials engineering [View project](#)



charged particle transport and swarm data [View project](#)

Spatial profiles of atomic oxygen concentrations in a large scale CCP reactor

S. Lazović^{(*)1,2}, K. Spasić¹, N. Puač¹, G. Malović¹, U. Cvelbar², M. Mozetič², Z. LJ. Petrović¹

¹ Institute of Physics, University of Belgrade, Pregrevica 118, 11080 Belgrade, Serbia

² Jozef Stefan Institute, Jamova 39, 1000 Ljubljana, Slovenia

^(*) lazovic@ipb.ac.rs

Nickel catalytic probe was used to measure atomic oxygen concentrations in a large scale cylindrical asymmetrical capacitively coupled plasma reactor. We have measured O concentrations in the main chamber of the reactor as well as in the side tube placed perpendicular to the chamber wall. The spatial profiles in these two regions differ both in magnitude (10^{19} m^{-3} vs. 10^{18} m^{-3} or even 10^{17} m^{-3}) and in the way the concentrations decrease when moving away from the powered electrode. This is explained by the different chamber wall configuration around the probe and its proximity because the grounded walls are also O atom drain due to the recombination. Working gas was air at 300 and 600 mTorr and the power was fixed at 500W.

Low temperature plasmas at sub-atmospheric pressures are an essential tool in many industrial processes due to variety of chemical reactions that can be induced and controlled while maintaining low gas temperatures. Low pressure radiofrequency plasmas are irreplaceable in the semiconductor industry but this is hardly the only field of their application [1, 2]. A large scale cylindrical asymmetrical 13.56 MHz CCP reactor was developed in our laboratory for the purpose of textile, polymer and seeds modification [3, 4]. Sensitive material treatment requires low ion energy bombardment and high concentrations of active species like O. For instance the formation of new oxygen-containing groups on the fiber surface is suggested to be due to the presence of extremely reactive atomic oxygen species in discharge during the air plasma processing and/or post-plasma chemical reactions when the activated fiber surface reacts with environmental species [5]. The asymmetric design of the reactor was chosen to provide low energies of ions bombarding the surfaces of the samples in order to avoid excessive damage of the samples.

We have used nickel catalytic probe positioned side-on to the powered electrode to measure O concentrations in the main chamber and in the small side tube (see Fig 1.).

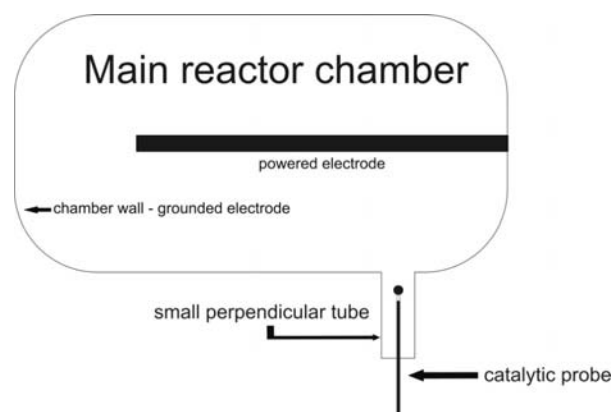

Fig. 1: Catalytic probe position in the reactor.

Detailed experimental setup details can be found elsewhere [6] as well as the design and the operation of the catalytic probe [7, 8]. Measurements are performed in air at 300 and 600 mTorr. The power was fixed at 500 W.

Spatial profiles of O concentrations are shown at Fig 2. We can see that the concentrations are higher at higher pressure and are decreasing faster in the side tube compared to the main chamber when moving away from the powered electrode. This is due to the difference in the vicinity and the area of the grounded wall which is closest to the probe at certain position.

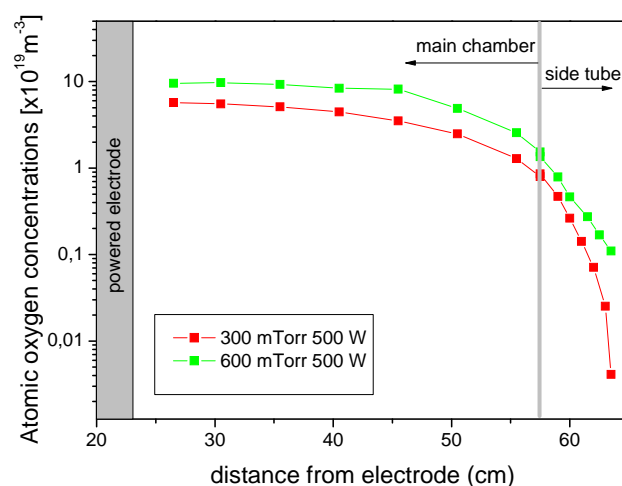

Fig. 2: Atomic oxygen spatial profiles in the main reactor chamber and in the side tube. Working gas was air at 300 and 600 mTorr and the power was fixed at 500 W.

The surface recombination of O atoms is taking place at the surface of both the nickel catalytic probe and at the chamber wall. In the tube, the wall is a stronger O atom drain both because it is closer and because the effective area is larger. By placing the sample at different distances from the powered electrode O concentrations can be controlled in the range from 10^{17} m^{-3} to 10^{19} m^{-3} . Depending on the intrinsic properties of the material being treated and on the modification effects that are desired we can tune the O concentrations at the sample surface simply by putting the sample in one of two regions of the reactor (main chamber and side tube) and adjusting its position. Adjustment can also be achieved by changing the pressure, power and gas composition.

References

- [1] T. Makabe, Z.Lj. Petrović, *Plasma Electronics*, (2006) (Taylor and Francis, New York).
- [2] M.A. Lieberman, A.J. Lichtenberg, *Principles of Plasma Discharge and Materials Processing*, (2005) (Wiley, Hoboken).
- [3] N. Puač, Z.Lj. Petrović, M. Radetić and A. Đorđević, *Materials Science Forum*, **494** (2005) 291-296.
- [4] M. Radetić, P. Jovančić, N. Puač and Z.Lj. Petrović, *Workshop on Nonequilibrium Processes in Plasma Physics and Studies of the Environment*, SPIG 2006, *Journal of Physics: Conference Series* **71** (2007) 012017.
- [5] V. Ilić, Z. Šaponjić, V. Vodnik, S. Lazović, S. Dimitrijević, P. Jovančić, J. M. Nedeljković and M. Radetić, *Ind. Eng. Chem. Res.* **49** (2010) 7287–7293.
- [6] S. Lazović, N. Puač, K. Spasić, G. Malović, U. Cvelbar, M. Mozetič, Z. Lj. Petrović, *30th ICPIG*, August 28th – September 2nd (2011).
- [7] T. Vrlinic, C. Mille, D. Debarnot, F. Poncin-Epaillard, *Vacuum* **83** 5 (2009) 792–796.
- [8] M. Mozetic, A. Vesel, U. Cvelbar, A. Ricard, *Plasma Chem Plasma P* **26** (2006) 103–117.

ISBN 978-86-7031-244-9



26th Summer School and International
Symposium on the **P**hysics of **I**onized **G**ases

August 27th -31st, 2012, Zrenjanin Serbia

**CONTRIBUTED
PAPERS
&
ABSTRACTS OF INVITED LECTURES
AND
PROGRESS REPORTS**



Editors

M. Kuraica, Z. Mijatović

**University of Novi Sad, Faculty of Sciences
Department of Physics
Novi Sad, Serbia**

S3.39 S. Mijović, M. Vučeljčić and M. Šćepanović THE OPTICAL EMISSION SPECTROSCOPY EXPERIMENT OF OPEN AIR PLASMAS	293
S3.40 M. Šćepanović, M. Vučeljčić and S. Mijović, SPECTROSCOPIC TEMPERATURE MEASURE- MENTS IN A FREE-BURNING ZINCVAPOR ELECTRIC ARC	297
S3.41 S. N. Stamenković, V. Lj. Marković, S. R. Gocić, A. P. Jovanović, M. N. Stankov and N. D. Nikolić INFLUENCE OF SURFACE CHARGES ON DC GLOW DISCHARGE IN NEON WITH Au-Ni CATHODE SPOTS	301
S3.42 K. Spasić, S. Lazović, N. Puač, Z. Lj. Petrović, G. Malović, M. Mozetič and Uroš Cvelbar CATALYTIC PROBE MEASUREMENTS OF ATOMIC OXYGEN CONCENTRATION IN LARGE VOLUME OXYGEN CCP	305
S3.43 N. Selaković, D. Maletić, N. Puač, S. Lazović, G. Malović, A. Djordjević and Z. Lj. Petrović AXIAL PROFILES OF PLASMA BULLET WITH DIFFERENT ELECTRODE GAPS	309
S3.44 T. Gajo, I. Savić, R. Kobilarov and Z. Mijatović STARK WIDTHS OF SEVERAL Ar II SPECTRAL LINES EMITTED FROM PULSED ARC PLASMAS	313
S3.45 I. Savić, L. Gavanski, S. Djurović, Z. Mijatović and R. Kobilarov ICCD SPECTROMETER – CHARACTERIZATION OF INSTRUMENTAL LINE PROFILES AND SATURATION LEVEL DETERMINATION	317
S3.46 A. A. Kirillov, Y. A. Safronau, L. V. Simonchik, N. V. Dudchik and O. E. Nezhvinskaya DC ATMOSPHERIC PRESSURE GLOW DISCHARGE COLD PLASMA FOR BACTERIA INACTIVATION	321
S3.47 M. Savić, M. Radmilović-Radjenović, B. Radjenović THEORETICAL PREDICTIONS OF THE MICROWAVE BREAKDOWN FIELD	325
S3.48 M. Savić, M. Radmilović-Radjenović, D. Marić, M. Šuvakov, Z. Lj. Petrović MONTE CARLO SIMULATIONS OF RF BREAKDOWN	329
S3.49 S. Marjanović, A. Banković, M. Šuvakov, T. Mor- tensen, A. Deller, C. A. Isaac, D. P. van der Werf, M. Charlton, Z. Lj. Petrović COLLISION-DRIVEN POSITRON CLOUD EXPANSION – EXPERIMENT AND SIMULATION	333
S3.50 S. Marjanović, M. Šuvakov and Z. Lj. Petrović MONTE CARLO SIMULATION OF POSITRON TRAPPING EFFICIENCY	337

CATALYTIC PROBE MEASUREMENTS OF ATOMIC OXYGEN CONCENTRATION IN LARGE VOLUME OXYGEN CCP

Kosta Spasić¹, Saša Lazović¹, Nevena Puač¹, Zoran Lj Petrović¹, Gordana Malović¹, Miran Mozetič² and Uroš Cvelbar²

¹*Institute of Physics, University of Belgrade, Pregrevica 118,
11080 Belgrade, Serbia*

²*Jožef Stefan Institute, Jamova 39, 1000 Ljubljana, Slovenia
e-mail: kostasp@ipb.ac.rs*

Abstract. Large scale chamber with asymmetric electrodes has been developed for low pressure treatment of seeds textile and wool. Since neutrals in plasma have very active role, it is of great importance to analyze their behavior in discharges. For this paper we have used catalytic probe in order to determine concentrations and spatial profiles of atomic oxygen. This diagnostic tool has been chosen due to its low cost, simplicity and possibility of real-time use, which makes it suitable for industrial purposes.

1. INTRODUCTION

Catalytic probe is simple, yet effective tool for measuring concentration of neutral species. They are usually constructed as thermocouple and the hot end is the probe tip, where catalytic activity is taking place. Probe tip can be made of nickel [1], iron [2], copper [3], silver [4] and, gold [5]. This technique has been used for measurement of concentrations of atomic oxygen [1], nitrogen [6] and hydrogen [5], most frequently in RF plasmas, ICP [1] as well as CCP [7] and almost exclusively in low pressure. Some applications have also been reported in microwave discharges [6]. Recent research has proved that this kind of equipment can be used for continuous data acquisition [1].

In comparison with other methods for measuring concentration of neutral species catalytic probe comes at low price and it is simple to use. Direct interpretation of results is one of the biggest advantages of this method. Problem is that recombination coefficient cannot be determined with precision higher than 30% [1], so the probe itself cannot have accuracy above this mark. Even though probes are usually made to have small dimensions, their presence in discharge is still affecting plasma. When interpreting results, one should take care about the fact that probe cannot make difference whether species were excited or not when they arrived on its surface.

In our laboratory we have large scale discharge chamber in which we can have conditions similar to plasmas that are used for industrial purposes. Asymmetric geometry allows samples to be exposed to different intensity of treatment simply by adjusting their position. So far it has been used for treatment of wool [8], textile [9] and seeds [10].

Beside charged particles, neutral species have also very important role in plasma treatment. Presence of atomic oxygen in discharge can have influence on activation of surfaces of textile and seeds. Therefore, in order to have adequate treatment, it is of great importance to properly determine spatial profiles of atomic oxygen concentration inside the chamber. For this paper we have used nickel catalytic probe to measure concentration of atomic in CCP RF discharge at pressure of 450 mTorr.

2. EXPERIMENTAL SET-UP

Experimental set-up is shown on Figure 1. Our discharge chamber has cylindrical geometry. It is 2.5 m long and 1.17 m wide with walls, which are used as grounded electrode, made of stainless steel. Powered electrode is made of aluminum and it is placed axially, it is 1.5 m long and has diameter of 3 cm.

Our catalytic probe is placed side-on, perpendicular to powered electrode. Tip of it is disc made of nickel whose diameter is 1.5 mm and it is 0.04 mm thick. Since our probe is placed inside glass tube we have used Wilson seal to allow ease of movement and to secure that vacuum is maintained. Measurements were performed with real-time recording multimeter.

To create and sustain our plasma we have used 13.56 MHz power supply and matching network. Vacuum is achieved by mechanical pump, while needle valve was used to control flow of working gas.

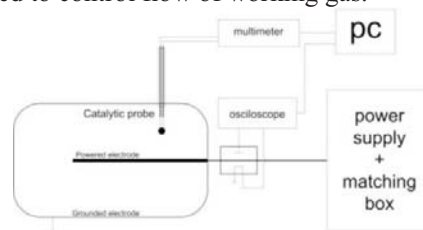

Figure 1. Experimental set-up.

3. RESULTS AND DISCUSSION

Typical measurements with catalytic probe require plasma to be turned off whenever data acquisition is needed. Speed of probe tip cooling when discharge is turned off provides information about power that is transferred to it when plasma is turned on. Since recombination is main cause of probe tip temperature increase, heating power can be used to derive atomic oxygen

concentration [11]. It has been discovered that, for same gas and same plasma parameters, temperature time derivative of probe tip depends on maximum temperature [2]. When that dependency is known, atomic oxygen concentration can be determined in real-time while plasma is on without interruption.

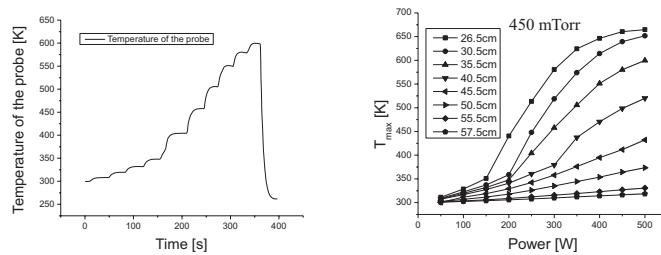

Figure 2. Standard measured curve (left), and maximum temperatures for whole set of measurements (right).

On Figure 2, on the left hand side, we have presented one of typical measured curves. We can see that after applying certain power, temperature is starting to rise and after few seconds it reaches saturation or maximum temperature, T_{max} . On the right hand side of the picture, set of maximum temperatures for different conditions is presented.

Spatial profiles of atomic oxygen concentration in large scale CCP device at 450 mTorr are shown in Figure 3. The closest distance to the powered electrode where measurements were taken was chosen according to technical capabilities and it was 26.5 cm. The most distant point was at chamber wall. Applied RF power was between 50 W and 500 W with increasing step of 50 W.

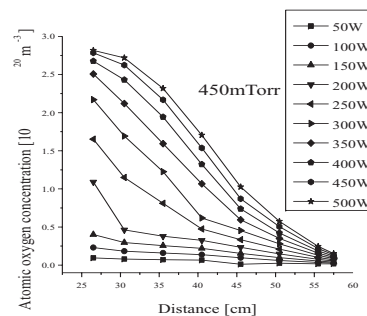

Figure 3. Spatial profiles of atomic oxygen concentration for different applied RF power at 450mTorr.

In the vicinity of the powered electrode the highest concentrations of $2.75 \cdot 10^{20} \text{ m}^{-3}$ were recorded. As probe was moved closer to the chamber wall concentrations were decreasing, and at the lowest point they were more than one order of magnitude lower. This big difference can be, in part, explained by very different size of electrodes. The biggest drop is between 35 cm and 45 cm.

For fixed position of the probe, rising of applied RF power resulted in rise of concentration of atomic oxygen

4. CONCLUSION

Catalytic probe was used to diagnose large volume CCP discharge at 13.56 MHz in oxygen at 450 mTorr for powers between 50 and 500 W. The highest concentrations are measured near the powered electrode, while at the chamber wall we measured concentrations that were order of magnitude lower. Higher applied power also produced higher concentrations. Since in all plasma treatments oxygen atoms play crucial role it is important to know concentrations of O atoms in order to be able to optimize the treatments. Also, knowledge of atom concentrations for different distances and different applied powers gives us opportunity to finely tune the treatments for variety of samples by just adjusting the distance from the powered electrode. It is shown that for the smaller distances from the powered electrode similar concentration of O atoms can be obtained as for greater distances, but much higher powers and this can significantly reduce the cost of treatments since same effects can be obtained for smaller power consumption

Acknowledgements

This research has been supported by the Ministry of Education and Science of Serbia under the contract numbers III41011 and ON171037

REFERENCES

- [1] I Šorli and R Ročak, J. Vac. Sci. Technol. A 18 2, 0734-2101 (2000)
- [2] M Mozetic, A. Vesel, U. Cvelbar and A. Ricard, Plasma Chem Plasma Process 26:103 (2006)
- [3] M Mozetic and U Cvelbar, Plasma Sources Sci. Technol. 18 034002 (2009)
- [4] M R. Carruth and A F Whitaker, Rev. Sci. Instrum., 61 (4) (1990),
- [5] M. Mozetic et al, Journal of Nuclear Materials 363, 1457 (2007)
- [6] F Gaboriau, U Cvelbar, M Mozetic, A Erradi and B Ruffet, J. Phys. D: Appl. Phys. 42 055204 (2009),
- [7] T. Vrlinic et al., Vacuum 83 792 (2009)
- [8] M Radetic, D Radojevic, V Ilic , D Jovic, D Povrenovic, N Puać, Z Lj. Petrovic and P Jovancic , Trends in Applied Sciences Research, 1 564 (2006)
- [9] M Radetić, P Jovančić, N Puać, Z Lj Petrović, Z Šaponjić, Textile Research Journal 79 558 (2009)
- [10] N. Puać, Z.Lj. Petrović, S. Tivković, Z. Giba, D. Grubišić and A.R. Đorđević, Plasma Processes and Polymers, 203 (2005),
- [11] A Drenik, U Cvelbar, K Ostrikov and M Mozetic, J. Phys. D: Appl. Phys. 41 11520 (2008)



ECM 112
ICAPT2011

112 IUVSTA EXECUTIVE COUNCIL MEETING AND 4TH
INTERNATIONAL CONFERENCE ON ADVANCED PLASMA
TECHNOLOGIES WITH WORKSHOP

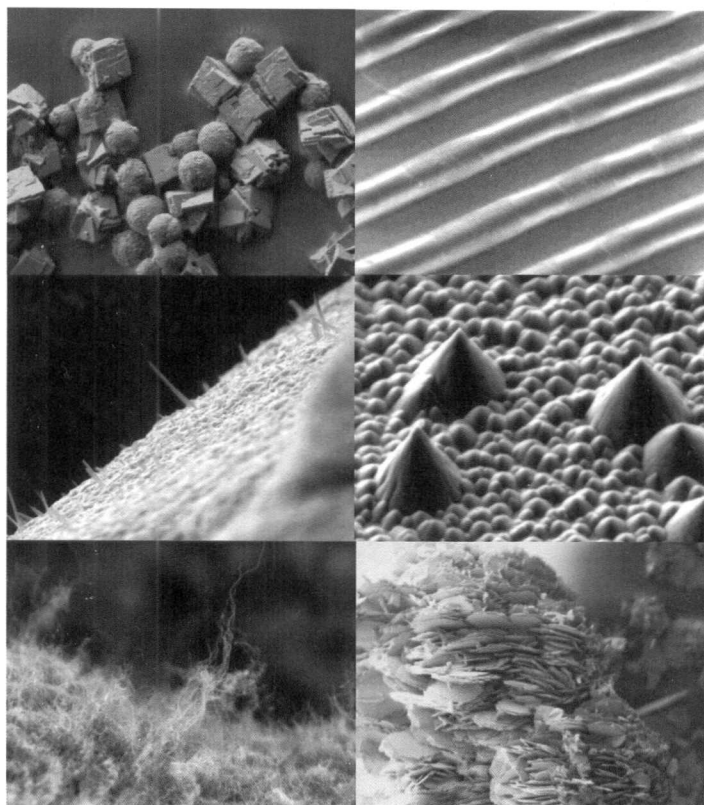

CONFERENCE PROCEEDINGS

Sep 9th-13th 2011 | Strunjan, Slovenia, EU

© DVTS 2011 All rights reserved.

All rights reserved. No part of this publication may be reproduced, stored in a retrieval system or transmitted in any form or by any means, electronic, mechanical, photocopying, recording or otherwise, without the prior permission of the publisher.

No responsibility is assumed by publisher for any injury and/or damage to persons or property as a matter of products liability, negligence or otherwise, or from any use or operation of any method, products, instructions or ideas contained in the material herein.

Editors of Proceedings: Miran Mozetič and Uroš Cvelbar

Published by: Slovenian Society for Vacuum Technique (DVTS Društvo za vakuumsko tehniko Slovenije), Teslova 30, SI-1000 Ljubljana, Slovenia

Graphic design: Kristina Eleršič

Printed by: Infokart d.o.o., Ljubljana

Ljubljana, September 2011

CIP - Kataložni zapis o publikaciji
Narodna in univerzitetna knjižnica, Ljubljana

533.9(082)
620.3(082)

INTERNATIONAL Conference on Advanced Plasma Technologies (4 ; 2011
; Strunjan)

Conference proceedings / 4th International Conference on
Advanced Plasma Technologies (iCAPT-IV), September 11th - September
13th 2011, Strunjan, Slovenia ; [editor Miran Mozetič]. - Ljubljana
: Slovenian Society for Vacuum Technique = DVTS - Društvo za
vakuumsko tehniko Slovenije, 2011

ISBN 978-961-92989-3-0
l. Mozetič, Miran, 1961-

257634560

<p>P-29</p>	<p><i>ICCD images of plasma bullets for two different electrode configurations</i></p>	<p>D. Maletić, N. Puač, S. Lazović, G. Malović, A. Đorđević and Z. Lj. Petrović</p>
<p>P-30</p>	<p><i>Automatisation of Processing of Fibre Optics Catalytic Probe Signals</i></p>	<p>A. Drenik, A. Tomelj, R. Zaplotnik and M. Mozetič</p>
<p>P-31</p>	<p><i>Photocatalytically active printing ink based on the redox dye 2,6-dichloroindophenol</i></p>	<p>A. Pondelak, A. Sever Škapin, R. Urbas, M. Klanjšek Gunde</p>
<p>P-32</p>	<p><i>Encapsulation of nano-dimensional organic pigments by silica</i></p>	<p>E. Švara Fabjan, A. Sever Škapin, M. Otoničar, M. Gaberšček</p>
<p>P-33</p>	<p><i>Diagnostics of a large scale CCP reactor suitable for textile treatments</i></p>	<p>S. Lazović, N. Puač, K. Spasić, G. Malović, U. Cvelbar, M. Mozetič and Z. Lj. Petrović</p>
<p>P-34</p>	<p><i>Study of the effect of firing process on photocatalytic activity of external self-cleaning ceramic tiles</i></p>	<p>A. Sever Škapin, V. Ducman</p>

Diagnosics of a large scale CCP reactor suitable for textile treatments

Saša Lazović^{1,2}, Nevena Puač¹, Kosta Spasić¹, Gordana Malović¹, Uroš Cvelbar², Miran Mozetič² and Zoran Lj. Petrović¹

¹Institute of Physics, University of Belgrade, Pregrevica 118, 11080 Belgrade, Serbia

²Department of Surface Engineering, Jozef Stefan Institute, Jamova cesta 39 (Street and number), 1000 Ljubljana (Town), Slovenia

lazovic@ipb.rs

Radiofrequency glow discharges at low pressure can occupy large volumes of space and therefore are convenient for treatment of large samples. Rolls of textile also require nondestructive and sensitive treatments which will not damage fiber structure. Non equilibrium plasmas can provide treatments without heating and damaging of the samples but with very high and controllable presence of active species needed for specific treatment effects. Geometrically asymmetric CCP chamber provides ions of lower energies coming to the surfaces (due to small powered to grounded area ratio) but also maintain high active radical concentrations. By changing the parameters such as pressure, gas composition, and power delivered to the plasma and by placing the sample at different distances from the powered electrode ratio of presence of active species to ion bombardment at the sample surface can be regulated. We have used derivative, Langmuir and catalytic probes to diagnose plasma produced in a large scale asymmetric CCP reactor (see Figure 1. for experimental setup). Plasma is around 2 m³ in volume, uniform, stable from transition to streamers and can operate for long periods of time. Working gas was air.

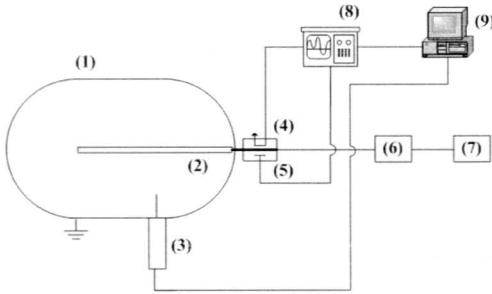

Figure 1. Experimental set-up: (1) Chamber, (2) Powered electrode, (3) Catalytic or Langmuir probe (4) Current probe, (5) Voltage probe, (6) Variomatch, (7) Power supply, (8) Oscilloscope, (9) Computer

Derivative probes are used to determine the power delivered to the plasma. Figure 2. shows average power versus power given by RF generator delivered to the plasma in air at 100, 200, 400, 600 and 800 mTorr.

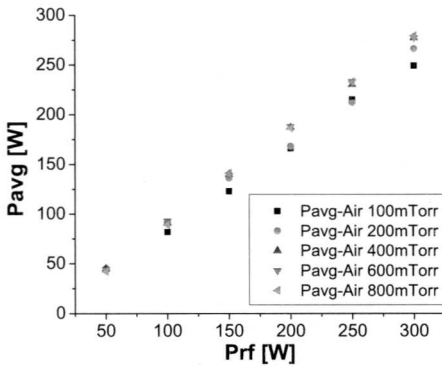

Figure 2. The average power delivered to the plasma vs. power given by RF generator measured by using derivative probes (air at 100, 200, 400, 600 and 800 mTorr).

We can see that almost all the power given by the power supply goes into the plasma. Also, average power delivered to plasma is not strongly dependent on pressure. Langmuir probe (Hiden ESPION system) was used to determine the concentrations of ions at several distances from the powered electrode, where samples can be placed (see Figure 3.).

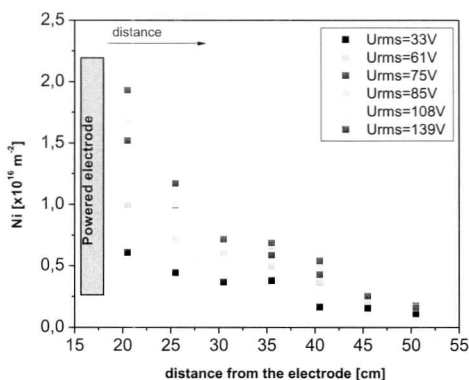

Figure 3. Ion concentrations at different distances from the powered electrode.

Concentrations are highest close to the powered electrode and are decreasing as we move further away towards the chamber walls. The change of voltage has the strongest impact on the values of ion concentrations at the positions closest to the powered electrodes, and at the position closest to the grounded chamber wall its influence is very small. Catalytic nickel probe was used in order to obtain concentrations of oxygen atoms. Concentrations were measured in air at different pressures and at 57.5 cm from the powered electrode (see Figure 4.). Plasma is ignited with specific value of power being set, the probe is being heated by the plasma to a certain temperature, plasma is turned off and from the slope of probe temperature decrease the atomic oxygen concentrations are determined.

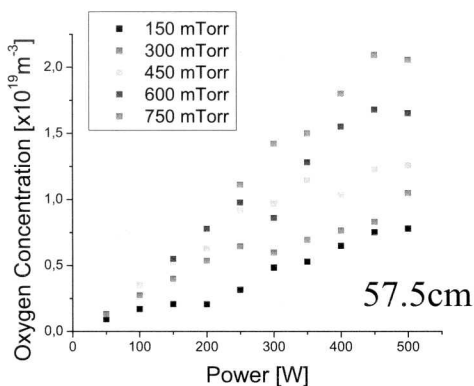

Figure 4. Oxygen atom concentrations as a function of RF generator power for different values of pressure.

Oxygen concentrations are of the order of 10^{19} m^{-3} and are increasing with the applied power and with the increase of pressure. Concentrations are also increasing when we get closer to the powered electrode. Importance of reactive oxygen species lie in the fact that the formation of new oxygen-containing groups on the fiber surface is suggested to be due to the presence of extremely reactive atomic oxygen species in discharge during the air plasma processing and/or post-plasma chemical reactions when the activated fiber surface reacts with environmental species [1]. From the presented results on the average power delivered to the plasma, ion and atomic oxygen concentrations optimum treatment parameters can be found so that the treatment effects (like enhanced wettability, dyeability and printability, shrink-resistance and antipilling properties to wool fibers) are the highest and the risk of damaging the samples the lowest.

Acknowledgements

This research has been supported by the MNTR, Serbia, under the contract numbers ON171037, III41011 and bilateral project Slovenia-Serbia.

Reference

- [1] V. Ilić, Z. Šaponjić, V. Vodnik, S. Lazović, S. Dimitrijević, P. Jovančić, J. M. Nedeljković, and M. Radetić, Bactericidal Efficiency of Silver Nanoparticles Deposited onto Radio Frequency Plasma Pretreated Polyester Fabrics, *Industrial & Engineering Chemistry Research* (2010) vol 49,p. 7287–7293

Measurements of atomic oxygen concentrations in a large scale asymmetric capacitively coupled plasma reactor by using catalytic probes

S. Lazović^{1,2}, N. Puač¹, K. Spasić¹, G. Malović¹, U. Cvelbar², M. Mozetič², Z. Lj. Petrović¹

¹ Institute of Physics, University of Belgrade, Pregrevica 118, 11070 Belgrade, Serbia

² Jozef Stefan Institute, Jamova 39, 1000 Ljubljana, Slovenia

A large scale cylindrical asymmetric capacitively coupled plasma reactor is suitable for efficient treatment of materials like polymers, textile and plant seeds. Plasma is homogeneous and stable from transitions to streamers providing uniform and safe treatment of sensitive materials. For many biomedical and textile treatment effects, role of extremely reactive atomic oxygen species is very important. Measurements were performed using nickel catalytic probe placed side-on to the powered electrode. Concentrations of neutral oxygen atoms were measured for a range of powers given by the RF generator, at several different distances from the powered electrode, in air at two different pressures.

1. Introduction

Radiofrequency discharges are necessary for treatment of isolators and semiconductors [1]. Different kinds of conductive and non-conductive materials like microelectronics devices [2-4], biological samples [5] and textiles [6] can be treated using capacitively coupled RF plasmas. Organic samples and materials may be removed by ashing with potential applications in microelectronics and medicine.

A large scale CCP RF reactor was developed in our laboratory in order to treat cheaply and uniformly textile rolls without damaging the surface of the fibers. Homogeneous and stable plasma, without transition to streamers, capable of long term stable operation (i.e. treatments) was achieved. Detailed electrical characterization of the plasma reactor using derivative probes can provide information on the relations between external discharge properties (current and voltage waveforms, impedance) and plasma parameters (densities, energies, fluxes of charged particles). Textile samples can be placed in the chamber at several distances from the powered electrode providing various intensities of treatment. Langmuir probe measurements can provide us with ion and electron concentrations at positions where samples would be placed. These measurements show complex spatial dependences of the concentrations and are important for proper characterization of treating procedures. These measurements were part of our previous work.

Treatment and sample surface interactions are depended not only on plasma and chemistry but also on post plasma chemistry and related processes. We have used catalytic probe in order to measure concentrations of oxygen atoms.

2. Experimental setup

The discharge chamber is 2.5 m long and 1.17 m in diameter and made of stainless steel. Powered electrode is placed axially in the centre of the chamber and is 1.5 m long, 3 cm in diameter and made of aluminum. Outer chamber wall is the grounded electrode. The rest of the electrical circuit consists of RF power generator Dressler Cesar 1010 in combination with Variomatch matching network. Derivative probes, which can be used to measure the power delivered to the plasma itself are placed into a stainless steel box opposite to each other. The box is placed as close as possible to the end of the powered electrode. Low pressures are maintained using mechanical vacuum pump with a constant flow of gas air (see Fig.1).

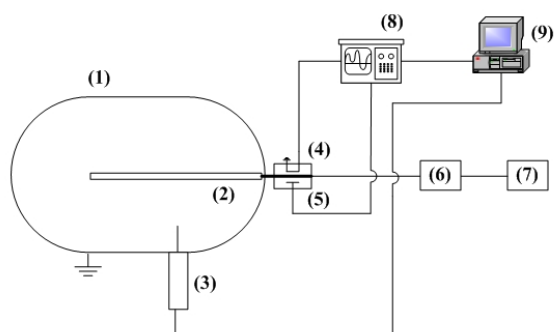

Figure 1. Experimental set-up: (1) Chamber, (2) Powered electrode, (3) Catalytic probe (4) Current probe, (5) Voltage probe, (6) Variomatch, (7) Power supply, (8) Oscilloscope, (9) Computer

Catalytic probe was mounted perpendicular to the powered electrode. The tip of the probe is in a shape of a disk made of nickel, 3 mm in diameter and

0.04 mm thick. The probe is 50 cm long and placed in a glass tube with sealed contact conductors on the other side. Digital voltmeter (Iso-Tech IDM73) connected to the computer was used to record changes of voltage signals from the probe. Voltage signal is recorded with a frequency of 2 Hz. Catalytic probe is being heated by the recombination processes of atomic oxygen at the surface of the nickel probe tip. Recorded voltage waveform corresponds to the probe temperature signal. When plasma is turned off, concentration of neutral oxygen atoms decrease. Concentrations can be calculated from the slope of that decrease.

3. Results and discussion

Plasma was ignited in air at two pressures (300 mTorr and 750 mTorr) and power was changed in range from 0 to 500 W. Probe was placed at 47.5, 42.5 and 37.5 cm from the powered electrode. Voltage signals from the catalytic probe are recorded before, during and after plasma formation. Voltage signals correspond to temperature of the probe and oxygen atom concentrations are proportional to the time derivative of temperature. When plasma is ignited, probe temperature increases (depending on how fast RF power is being increased). When a certain value of RF power is reached, temperature saturates. Pressure in the chamber increases when plasma is ignited so it is needed to adjust the pressure to 300 or 750 mTorr. After that, plasma is turned off and temperature starts to decrease. Atomic oxygen concentrations are proportional to the slope of that decrease with the constant depending on probe mass, area, specific heat capacitance and γ coefficient for nickel as well as on thermal velocity of O atoms and dissociation energy of oxygen molecules [7].

Results at 300 mTorr for three distances are shown at Figure 2. We can see that atomic oxygen concentrations are lowest when the probe is positioned closest to chamber wall (47.5 cm). The concentration increases with the increase of power delivered to plasma. When the probe is positioned closer to the powered electrode, concentrations also increase. For shorter distances (42.5 cm and 37.5 cm) we did not cover the whole power range (0-500 W) because of intensive probe glowing due to ion bombardment of the probe surface. At 47.5 cm distance, probe was not glowing for the 0 to 200 W power range. Above this range, glowing of the probe is increasing with power. At 42.5 cm the probe was not glowing only in the 0 – 50 W power range. For the shortest distance (37.5 cm) the probe was glowing for all values of RF power. Glowing of

the probe was not noticed at 750 mTorr for 47.5 cm distance.

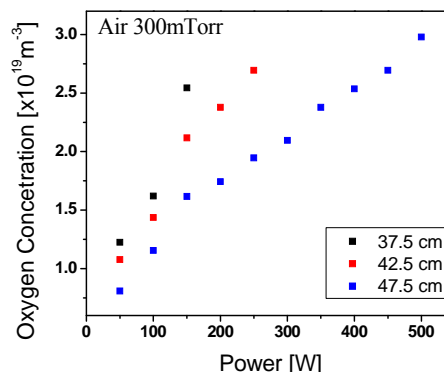

Figure 2. Atomic oxygen concentrations as a function of RF power for three different distances from the powered electrode. Air pressure was 300 mTorr

Oxygen concentrations as a function of RF power at 300 mTorr and 750 mTorr are shown at Figure 3.

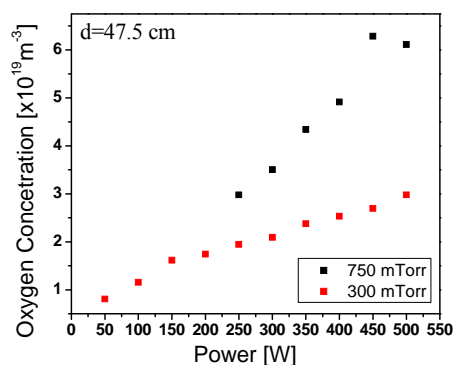

Figure 3. Atomic oxygen concentrations as a function of RF power. Distance between probe tip and the powered electrode was 47.5 cm. Chamber pressure was 300 and 750 mTorr.

For the pressure of 300 mTorr plasma is filling the whole chamber area already at several tens of watts. At 750 mTorr this happens for 250 W and higher (this is why power range at 750 mTorr goes only from 250 W to 500 W). We can see that the oxygen concentrations are higher at 750 mTorr compared to 300 mTorr and are increasing with RF power.

4. Conclusion

Neutral oxygen atom concentrations are measured in a large scale CCP plasma reactor. Discharge was generated in air at 300 mTorr and 750 mTorr. Measurements were performed at 47.5, 42.5 and 37.5 cm from the powered electrode. RF power given by the generator was varied from 0 to

500 W. This kind of plasma is suitable for treatment of different kinds of textile. Both plasma and post plasma effects at sample surface are important to study and understand for the sake of successful applications. The formation of new oxygen-containing groups on the fiber surface is suggested to be due to the presence of extremely reactive atomic oxygen species in discharge during the air plasma processing and/or post-plasma chemical reactions when the activated fiber surface reacts with environmental species [8]. Oxygen atom concentrations coming to the surface of the samples can be controlled by adjusting the pressure, distance from the powered electrode and RF power.

5. References

[1] A. Bogaerts et al. / *Spectrochimica Acta Part B* 57 (2002) 609–658.

[2] M.A. Lieberman, A.J. Lichtenberg, *Principles of Plasma Discharge and Materials Processing*, (2005) (Wiley:Hoboken).

[3] T. Makabe, Z.Lj. Petrović, *Plasma Electronics*, (2006) (Taylor and Francis:New York);

[4] U. Cvelbar, K. (Ken) Ostrikov and M. Mozetic, *Nanotechnology* 19 (2008) 405605.

[5] N. Puač, Z.Lj. Petrović, S. Živković, Z. Giba, D. Grubišić and A.R. Đorđević, *Plasma Processes and Polymers*, (2005) 193, (Wiley)

[6] M. Radetić, P. Jovančić, N. Puač and Z.Lj. Petrović, *Workshop on Nonequilibrium Processes in Plasma Physics and Studies of the Environment*, SPIG 2006, *Journal of Physics: Conference Series* 71 (2007) 012017

[7] M. Mozetic, U. Cvelbar, A. Vesel, A. Ricard, D. Babic and I. Poberaj, *Journal of Applied Physics*, 97 (2005) 103308

[8] V. Ilić, Z. Šaponjić, V. Vodnik, S. Lazović, S. Dimitrijević, P. Jovančić, J. M. Nedeljković and M. Radetić, *Ind. Eng. Chem. Res.* 49 (2010), 7287–7293

Reactive species production in oxygen low-pressure RF plasma suitable for treatment of sensitive surfaces

K. Spasić, N. Škoro, N. Puač, G. Malović and Z. Lj. Petrović
Institute of Physics, University of Belgrade, Pregrevica 118, 11080 Belgrade, Serbia
e-mail:kostasp@ipb.bg.ac.rs

Abstract For the purpose of large scale plasma treatment, we have created asymmetric CCP plasma reactor that operates at 13.56MHz. Its geometry allows stable plasma conditions without possibility for the creation of streamers which is suitable for treatment of sensitive samples. To achieve best possible conditions it is of utmost importance to get well acquainted with chemical processes in plasma inside the reactor. For that purpose we have applied mass spectrometry and optical actinometry. We have used these two techniques in order to obtain number of oxygen atoms created in the discharge. The measurements were conducted for pressures of 300 and 450 mTorr and for the range of power from 100 to 500 W.

INTRODUCTION

We have developed asymmetric plasma reactor which is suitable for treatments of sensitive samples. It was already used for successful treatment of seeds [1] [2], wool and textile [3] [4], but for industrial scale processing and optimization it is necessary to perform complete diagnostic of all active species. Beside charged particles neutral species have significant role in activation of sample surfaces. One of the most important is very reactive atomic oxygen. With mass-energy analyzer we were able to measure number of oxygen atom created in the discharge. Apart from mass energy analyzer we used optical actinometry as another diagnostic technique. The use of actinometry is straightforward since it is non-intrusive and requires adding of very small amount of noble gas (actinometer). Generally, the ratio of lines from working gas and actinometer can be used to determine absolute atom concentration. By combining these two techniques, we hope that it will be possible to use mass spectrometer for high precision concentration measurements.

EXPERIMENTAL SET-UP

In order to find optimal conditions for plasma treatment of various sensitive samples, such are textile, seeds or wool, we have created prototype of a device which has dimensions required for industrial scale usage. RF power at 13.56 MHz is supplied by Dressler Cesar 1310 and Variomatch matching network. Cylindrically shaped outer wall of our reactor, which is made of stainless steel, serves as the grounded electrode. The reactor chamber is 2.5 m long and has a diameter of 1.17 m. Powered electrode is 1.5 m long aluminum rod (3 cm in diameter) placed along the central axis of the chamber. HIDEN EQP mass spectrometer is mounted side-on and the distance of the mass spectrometer orifice from the powered electrode is 30 cm. The diameter of the orifice is 100 μm and it is positioned at the level of the powered electrode. Mass spectra of neutral atoms are acquired with resolution of 0.1 amu ranging from 0.4 up to 50 amu. The energy of the electrons used in obtaining mass spectra was 70 eV. At this electron energy, the collected atoms at the detector are the sum of atoms created in the plasma together with atoms created in the mass spectrometer due to the dissociation of oxygen molecules. Apart from mass spectra, we measured number of oxygen atoms created in the plasma. In this case, the number of oxygen atoms is measured as a function of energies of the electrons originating from

the filament of mass spectrometer. The range of electron energies was from 4 eV to 35 eV with resolution of 0.1 eV. Additionally, optical emission from the electrode region was recorded through a window. Plasma emission was focused using a lens to an entrance slit of a monochromator (Oriel MS127i) equipped with i-Star Andor ICCD camera as detector. Recording time of the spectra was several hundred ms, so light emission from many RF periods was integrated. Applied powers were between 100W and 500 W at pressures of 300 and 450 mTorr. The working gas mixture was 99% of oxygen and 1% of argon.

RESULTS AND DISCUSSION

In Fig. 1 we show parts of O₂/Ar plasma spectra in visual and near IR wavelength range. Characteristic lines of atomic O and Ar were identified and marked in the figure. Relative scaling of the lines is preserved for both plots.

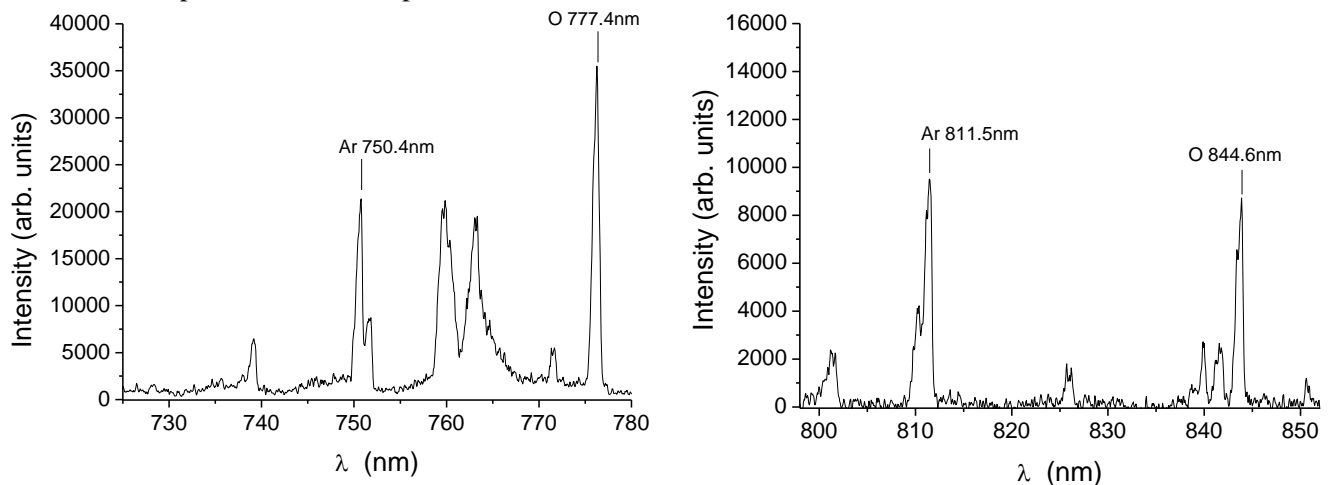

Fig.1 Characteristic parts of plasma spectra with designated lines of atomic O and Ar. Spectra recorded at 300 mTorr in 99% O₂/1% Ar gas mixture at 300 W.

Ratios of line peak intensities are presented in Fig. 2. The ratios between lines O-777.4 nm and Ar-750.4 nm and lines O-844.6 nm and Ar-811.5 nm are plotted as a function of power for two pressures: 300 mTorr and 400 mTorr. Ratios of O-777.4 nm and Ar-750.4 nm lines have steeper increase at powers above 300 W than ratios of O-844.6 nm and Ar-811.5 nm lines. For all cases, values of the ratios at higher pressure lie below the results obtained from measurements at lower pressures.

Line ratios of atomic O and Ar lines can be employed for determining the concentration of oxygen atomic species in the plasma using a simple optical emission actinometry [5,6]. Provided that conditions for actinometry calculations are met [7], concentrations of atomic oxygen and argon are proportional to their relative emission intensities. Thus, a steady increase in the line intensity ratios with power is a measure of an increase of the density of atomic O. At higher powers above 300 W, there are discrepancies between the increase of the line ratios' originating from different contribution of several available channels for atom excitation. In most cases, it is the of the dissociative excitation channel which appears at higher powers [8].

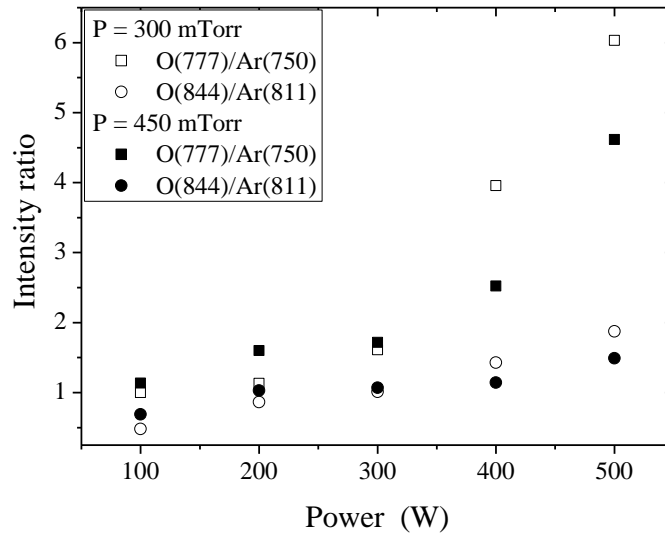

Fig.2 Intensity ratio of different line intensities at two pressures: 300 mTorr and 450 mTorr for different powers.

In order to get the number of oxygen atoms created in the plasma by using mass-energy analyzer we have scanned signal for mass 16 (O) for the range of electron energies from 4 to 35 eV with resolution of 0.1 eV. One typical scan is presented in figure 3 a). One can notice that when the discharge is turned off there is no signal for electron energies lower than 20 eV. This is due to the fact that the threshold energy for the dissociation of oxygen molecule is 20 eV [9] and signal for the mass 16 collected by the mass spectrometer originates from the dissociation of O₂ inside the analyzer. However, when plasma is turned on, oxygen atoms are created in the discharge and the counts for these atoms can be observed starting with electron energies as low as 4 eV. One should be aware that oxygen molecules are also collisionally excited inside the chamber to several metastable states, so that even electrons with energies lower than 20 eV can cause dissociation in the mass spectrometer.

To determine how many oxygen atoms are produced by plasma, one should normalize signal that is measured without plasma to the selected signal with plasma. Normalization is done only for the electron energies higher than 35 eV. We can assume under those conditions that detected signals originated only from the dissociation of the molecules. Total number of created neutral oxygen atoms is now equal to integrated difference of these two signals from the lowest measurable energy (4 eV) up to 20 eV [8].

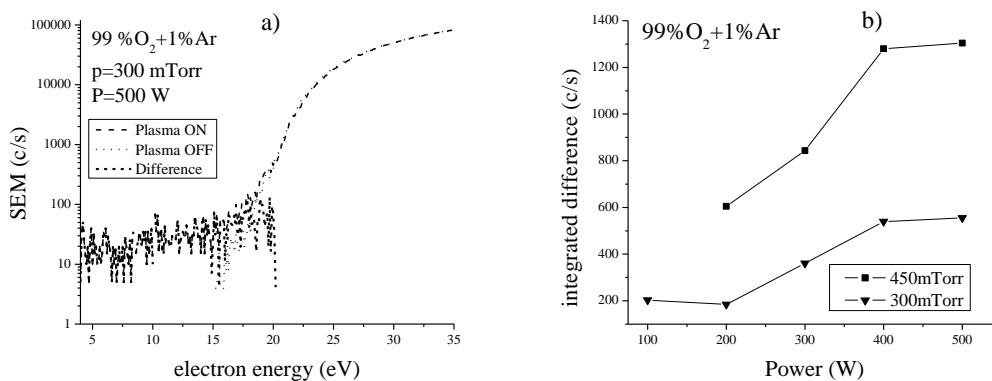

Figure 3. a) Electron energies for plasma turned off and on at power of 500W and at pressure of 300mTorr , b) Integrated difference for various powers at pressures of 300 mTorr and 450 mTorr.

In figure 3 b) we can see that O atoms count (integrated difference) is rising with the increase of power given by RF power supply. That is expected since with higher powers there is increase in dissociation of the O₂ in the discharge. The integrated difference presents a sum of all O atoms created in the discharge (excited, metastable, ground state) and detected by the mass-energy analyzer. However, one should be careful since there are also metastable O₂ molecules created in the plasma and the threshold for dissociation of these molecules is lower than for the dissociation of the O₂ in ground state. So, the obtained number of O atoms should be corrected for the number of atoms created in the mass-energy analyzer from the metastable molecules.

CONCLUSIONS

We have used optical actinometry and mass spectrum analyzer for diagnostic of a large scale CCP plasma reactor at 13.56MHz. We have detected characteristic lines of argon and oxygen and calculated their ratio as a measure of O atom concentration. With mass spectrometer set to electron energy mode relative number (counts per second) of atomic oxygen created in plasma was determined. Since these two methods are in good agreement we hope that we will be able to use mass spectrometer to measure total concentration of neutral species, such as atomic oxygen.

REFERENCES

- [1] N. Puač, Z.Lj. Petrović, S. Živković, Z. Giba, D. Grubišić and A.R. Đorđević, *Plasma Processes and Polymers*, Wiley 193-203 (2005).
- [2] S. Živković, N. Puač, Z. Giba, D. Grubišić and Z.LJ. Petrović, *Seed Science and Technology* **32** 693-701(2004).
- [3] M. Radetić, D. Radojević, V. Ilić, D.Jocić, D. Povrenović, N. Puač, Z.Lj. Petrović and P. Jovančić, *Trends in Applied Sciences Research* **1** 6 564-574 (2006).
- [4] M. Radetić, D. Radojević, V. Ilić, D. Jocić, D. Povrenović, B. Potkonjak, N. Puač and P. Jovančić, *J. Serb. Chem. Soc* **72** 6 605–614 (2007).
- [5] J. W. Cobrun, M. Chen, *J. Appl. Phys.* **51** 3134 (1980).
- [6] S. Radovanov, B. Tomčik, **Z.Lj. Petrović** and B. Jelenković, *J. Appl. Phys.* **67** 97 (1990)
- [7] H. M. Katsch, A. Tewes, E. Quandt, A. Goehlich, T. Kawetzki, and H. F. Doebele, *J. Appl. Phys.* **88** 6232 (2000).
- [8] J. P. Booth, O. Joubert, J. Pelletier and N. Sadeghi, *J. Appl. Phys.* **69** 618 (1991)
- [9] E. Stoffels, Y. Aranda Gonzalvo, T.D. Whitmore, D. L. Seymour and J. A. Rees, *Plasma Sources Sci. Technol.* **16** 549–556 (2007).

Plasma seeds treatment as a promising technique for seed germination improvement

I. Filatova¹, V. Azharonok¹, V. Lushkevich¹, A. Zhukovsky², G. Gadzhieva², K. Spasić³, S. Živković⁴, N. Puač³, S. Lazović³, G. Malović³ and Z.Lj.Petrović³

¹ Institute of Physics NAS of Belarus, Nezavisimosti Ave. 68, 220072 Minsk, Belarus

² Institute of Plant Protection NAS of Belarus, Mira Str. 2, 223011 Priluki, Minsk District, Minsk Oblast, Belarus

³ Institute of Physics, University of Belgrade, Pregrevica 118, 11080 Belgrade, Serbia

⁴ Institute for Biological Research "Siniša Stanković", University of Belgrade, Bulevar despota Stefana 142, 11060 Belgrade, Serbia

An influence of RF air plasma pre-sowing treatment on seed germination of some important agricultural plants has been studied. Two plasma systems (plan-parallel and cylindrical) were used for treatment of maize, spring wheat and lupinus seeds. It is shown that the treatments contribute to seeds germination enhancement decrease and their phytosanitary conditions improvement. The modification of seed coat surface structure by plasma irradiation is investigated with scanning electron microscopy and plasma emission spectra are analyzed for possible mechanisms determination of biological effect of plasma treatment.

1. Introduction

Cold plasma treatment is widely used for activation and decontamination of surfaces. Owing to the unique plasma features this technique is applicable for modification of a wide range of thermally sensitive materials including biological tissues. Recently it has been applied successfully for treatment of plant seeds [1–7]. Low temperature plasma pre-sowing seeds treatment was shown in some cases to be ecologically safe, cheap and effective method for improvement of seed germination and their resistance to stress and diseases.

At the same time there is a lack of research explaining the mechanism of plasma bio-stimulation. Possible processes were proposed in the literature. Plasma processing subjects the seed surface to UV radiation, charged particles bombardment, radicals and chemically active molecules resulting in the formation of functional groups on the treated surface [3, 4]. Air plasma treatment changes the wetting properties of seeds due to oxidation of their surface that leads to faster germination and greater yields [8], increases the concentration of free radicals in seeds which play an important role in acceleration of the seed metabolism [9]. The possibility of delay or enhancement of germination is demonstrated by plasma-induced coating with thin films containing different macromolecular components [10, 11]. It is obvious, that plasma treatment can have a variety of effects on morphological and sowing characteristics of seeds due to the complexity of plasma interaction with organic materials and living cells [12]. Seeds are an extremely complex system too, and vitally important

biological processes may be affected by the treatment in a number of different ways.

The aim of this paper is to study the efficiency of low-pressure RF air plasma treatment of seeds of some important agricultural crops for improvement of their sowing properties and to try to identify some of the main plasma agents that contribute to enhancement of germination.

2. Experimental

Seeds of spring wheat (*Triticum aestivum* L.), blue lupine (*Lupinus angustifolius*) and maize (*Zea mays* L.) were chosen for investigations. Tested species were treated with RF air plasma using two plasma systems. The first one was a planar geometry reactor operating at 5.28 MHz [5]. The electrode system consists of two identical water-cooled copper disks with the diameter of 120 mm placed in a stainless steel vacuum chamber. A supplied full specific RF power W could be changed in the range from 0.2 W/cm^2 to 0.6 W/cm^2 resulting in different treatment conditions. All species were treated at pressure of 500 mTorr. A Petri dish with seeds was put on the grounded (lower) electrode. Duration of the exposure was 2.5, 5, 8 and 10 min. Each Petry dish contained 50 seeds. All treatments for all experimental conditions were replicated four times. Control group was only subjected to vacuum and gas pressure $P=0.5$ Torr for at least 15 min. The gas temperature did not increase beyond 310°C .

The second plasma system used for pre-sowing treatment of seeds was a cylindrical CCP reactor operating at 13.56 MHz. In this system, a central, powered electrode is aluminum rod and the grounded

electrode is the wall of the chamber. A detailed description of the system can be found in [6]. The treated samples were placed in Petri dishes and put on a platform that is positioned at the bottom of the chamber. Every Petri dish housed 20 seeds with exception of maize where, due to seed size, only 10 seeds per dish were used. Total amount was 60 seeds per treatment. Spring wheat was treated at powers of 50 W and 100 W at pressure of 500 mTorr, while maize was treated at 300 mTorr with 200 W of applied RF power. Since different time of plasma exposure can cause very different results, this parameter was varied in a wide range (1min, 5min, 7min, 10min and 20 min).

The effectiveness of pre-sowing plasma seed treatments was examined by means of evaluation of the laboratory germination ability and biometric characteristics (mean root and plant length) of treated and control samples. Seeds were grown on a moist filter paper in sterile Petri dishes in a thermostat at 20° C (for wheat and lupine) and 25° C (for maize) under a light-dark regime. The seed germination and the seed infection were estimated after 7 and 10 days incubation for wheat and lupine/maize correspondingly.

Optical emission spectra (OES) were obtained with a Compact Spectrometer S100 "SOLAR LS" in the optical range from 190 to 1100 nm with an average spectral resolution of 1 nm to identify the species present in plasma during the treatment. Surface structure of the treated and untreated seeds was imaged with a high resolution scanning electron microscope (LEO 1455 VP).

3. Results and discussion

It has been found that plasma pre-treatments of seeds positively influenced their germination and biometric characteristics of sprouts. The results obtained in planar discharge are shown in Fig. 1. The plasma treatment of seeds with low germination ability (spring wheat, maize) stimulated their germination and the early stages of seedling development, while it did not affect negatively the germination of seeds with high germination ability (lupine). The seed pre-treatments for 2.5 and 5 min were the most effective for all species. The seedling of treated spring wheat was 2.1 cm higher than that in the control group (Fig. 1b). The same result was observed for maize seeds as a result of plasma treatment during 2.5 min. Large seedlings have a higher survival and growth rates than small seedlings that will provide good conditions for plant growth at the later stages of ontogenesis.

Similar results for plasma treatment of spring wheat and maize were obtained in asymmetric CCP

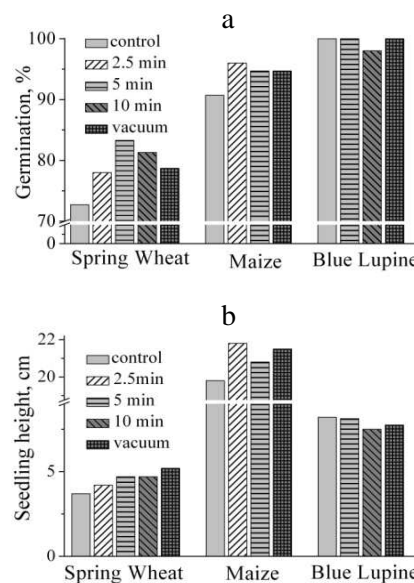

Fig. 1. Germination (a) and seedling height (b) of spring wheat, maize and blue lupine as a result of plasma and vacuum (without plasma) seed pre-treatments ($W = 0.2 \text{ W/cm}^2$, $P = 500 \text{ mTorr}$)

discharge. Results for spring wheat seed germination after plasma treatment at 50 and 100W are presented in Fig. 2. For both powers better results are achieved for shorter treatment times. Since the control group germination percentage is quite high the overall increase in germination percentage in treated batches is only few percent. Treatments with longer treatment times then 7 min showed a decrease in germination due to the damage of the seed inflicted by plasma bombardment. For higher power of 100 W and longer times this damage is quite high. In this case the germination percentage was reduced down to 70 %.

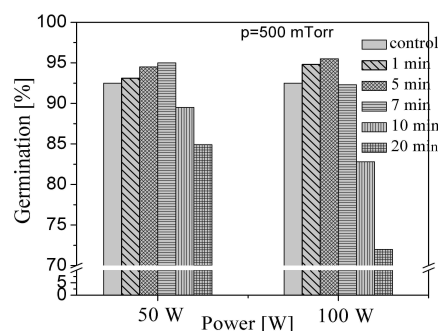

Fig. 2. Germination of spring wheat after plasma treatment in asymmetrical CCP discharge. Control represents untreated seeds. Feeding gas was air and the pressure was $P = 500 \text{ mTorr}$

Unfortunately most of the seeds used for commercial purpose are infected with different types of fungi (belonging to the genera *Mucor*, *Fusarium*,

Alternaria etc.). Therefore, it is important to check if same plasma conditions can be used to decrease the infection of seeds.

The results for infection percentage of spring wheat are shown in Fig. 3 for both plasma systems. We can see that we are able to reduce total infection in treated wheat seeds up to 10 min of treatment. For longer treatment times (20 min) the percentage of infected seeds increases. This is most probably due to the damage of the seed coat caused by treatment. The higher damage of the seed coat further increases seed's susceptibility to infection. Plasma treatment is shown as an effective tool against *Fusarium* spp. that causes the most harmful root disease of wheat worldwide.

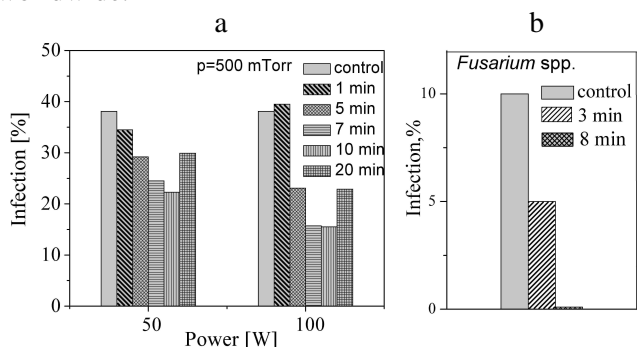

Fig. 3. Infection of spring wheat after plasma treatment in asymmetrical CCP discharge (a) and infection with *Fusarium* spp. after treatment in planar discharge (b). Control represents untreated seeds. Feeding gas was air at a pressure of $P = 500$ mTorr

Similar results are observed for maize and lupine (see Fig. 4 and 5).

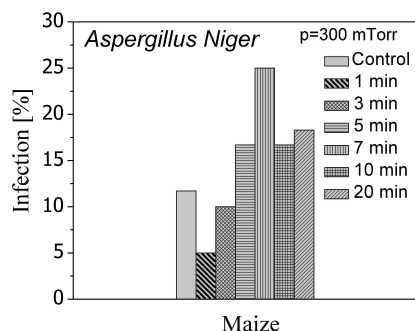

Fig. 4. Infection of maize after plasma treatment in asymmetrical CCP discharge. Control represents untreated seeds. Feeding gas was air at a pressure of $p = 300$ mTorr. Power given by RF power supply was 200 W

For lower treatment times in asymmetrical CCP discharge we have observed a decrease of the infected seeds percentage, but with an increase in treatment times infection spreads even more than in the control

group. We can conclude that both effects (germination increase & infection decrease) can be accomplished only for lower treatment times for the present setup of the asymmetrical CCP. For this pressure/power combination this interval is between 1 and 7 min of treatment. The same treatment durations (between 3 and 8 min) were the most effective against fungi and bacteria for treatment of maize and lupine seeds in planar discharge (see Fig. 5).

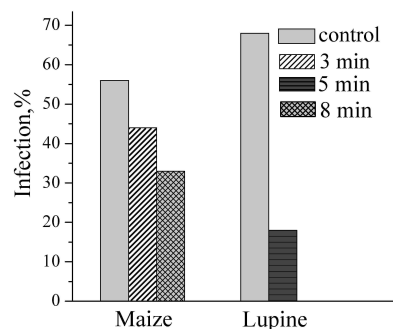

Fig. 5. Level of total infection of maize and lupine after plasma treatment in planar discharge. Control represents untreated seeds. Feeding gas was air at a pressure of $P = 500$ mTorr

It was revealed from the SEM images of seed coats that the surface structure of seeds changed sharply as a result of plasma treatment (Fig. 6). SEM indicated that the surface sculpture of untreated wheat seeds had a reticulate texture (Fig. 6a). The plasma treated wheat seeds had an eroded surface, with no significant ridges (Fig. 6b). The untreated lupine seed coat was formed by elongated polygonal cells (Fig. 6c).

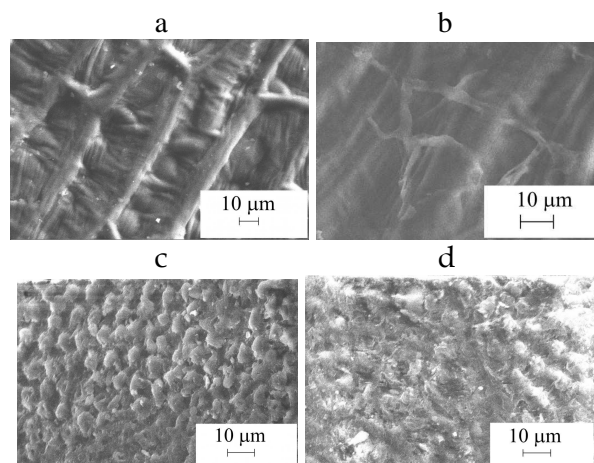

Fig. 6. Scanning electron micrograph (SEM) images of seed coat surface of wheat (a, b) (magnification = 2.00 KX) and blue lupine (c, d) (magnification = 1.00 KX) for non-treated (control) seed (a, c) and plasma treated for 5 minutes (b, d)

No well-defined cristate-papillate structure on the seed surface of lupine was observed after the plasma treatment. Similar results were obtained for another seeds which provided experimental evidence of the seed coat surface etching induced by plasma treatment [2, 3]. Study of the seed coat thicknesses after the plasma processing showed that the treatment removes effectively the very thin lipid layer that makes seeds water-repellent and probably reduces the length (and average molecular weight) of the biopolymer chains that make up the seed coat, thus enabling better water transport through the seed coat improving the germination [13].

In order to characterize the change of seed coat structure and seed germination as a function of plasma treatment conditions the OES spectra of the plasma were analyzed. The difference was observed between spectra generated by plasma without seeds and during their treatment (Fig. 7). The species identified in the spectra are neutral molecular nitrogen N_2 (bands of the first and the second positive systems), ionized molecular nitrogen N_2^+ (bands of the first negative system). When seeds are in the plasma bands of the Angstrom system of the CO molecule appear in the spectrum.

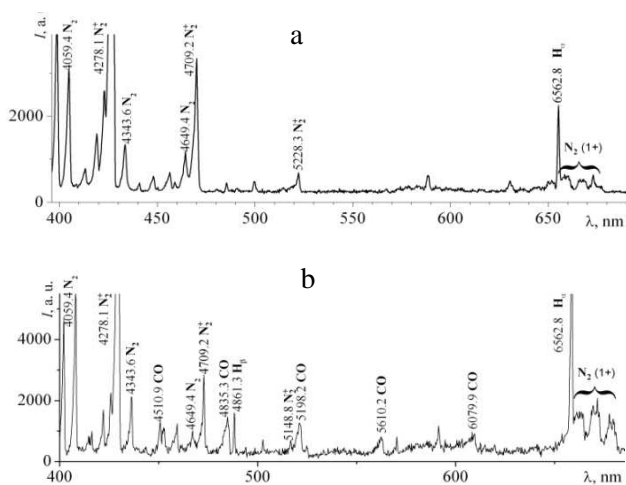

Fig. 7. Emission spectra of RF air plasma: a – pure air, b – under conditions of plasma treatment of wheat seeds

This confirms effectiveness of seed surface etching during the treatment and a possibility of formation of functional groups on treated surface that may play an important role in stimulation of seed germination [4, 5, 7].

4. Summary

This study confirms that the low temperature air plasma pre-treatment of seeds of some important agricultural crops is an effective tool for improvement of germination, shoot and root growth, providing a

good fungicidal and bactericidal effect in the optimal experimental conditions that can vary for different species. SEM investigations of seeds surface have shown a significant change in its texture that is an evidence of surface etching provided by bombardment by charged particles and radicals formed in plasma. Since the seed coat for treated samples are eroded it provides a better water permeability and leads to enhancement of seed germination.

Acknowledgements. This work is partly supported by the Belarusian Republican Foundation for Fundamental Research (grant No. F11SRB-015) and by the MES, Serbia, under the contract numbers ON171037 and III41011.

5. References

- [1] A. Dubinov, E. Lazarenko, V. Selemir, IEEE Trans. Plasma Sci. **20** (2000) 180.
- [2] M. Dhayal, S.Y. Lee, S.U. Park, Vacuum. **80**, No.5 (2006) 499.
- [3] B. Šerá, V. Straňák, M. Šerý, M. Tichý, P. Špatenka, Plasma Science and Technology. **10**, No. 4 (2008) 506.
- [4] S. Živković, N. Puač, Z. Giba, D. Grubišić, Z.Lj. Petrović, Seed Science and Technology. **32**, No. 3 (2004) 693.
- [5] I.I. Filatova, V.V. Azharonok, A. Shik et al., in: Plasma for Bio-Decontamination, Medicine and Food Security, ed. by Z. Machala et al., NATO Science for Peace and Security Series A: Chemistry and Biology, Springer (2012) 469.
- [6] N. Puač, Z.Lj. Petrović, S. Živković, Z. Giba, D. Grubišić and A.R. Đorđević, "Low temperature plasma treatment of dry Empress-tree seeds", Plasma Processes and Polymers, Eds. R. d'Agostino, P. Favia, C. Oehr and M.R. Wertheimer, (Wiley: (2005) 193.
- [7] M. Selcuk, L. Oksuz, P. Basaran, Bioresource Technology, **99** (2008) 5104.
- [8] <http://www.ncbi.nlm.nih.gov/pmc/articles/PMC3473364/pdf/srep00741.pdf>.
- [9] I.I. Filatova, V.V. Azharonok, N.A. Poklonski, et al., Proc. of the VII Int. Conf. Plasma Physics and Plasma Technology, September 16-21, 2012, Minsk, Belarus, ed. by V.M. Astashinski et al., Kovcheg, Minsk (2012) 734.
- [10] J.C. Volin, F.S. Denes, S.M.T. Park, R.A. Young, Crop Science. **40** (2000) 1706.
- [11] R.A.M. Carvalho, A.T. Carvalho, M.L.P. da Silva et al., Quim. Nova. **28**, No. 6 (2005) 1006.
- [12] B. Será, P. Špatenka, M. Šerý et al., Plasma Science, IEEE Transactions on Plasma Science. **38** (2010) 2963.
- [13] http://www.aff.org.au/Griesser_Plasma_treatment_of_%20seeds_Final.pdf.

Proceedings of the
XXth International Conference on Gas
Discharges and their Applications

gd
2014



Orléans - France

Volume 1

HEM logo

PROCEEDINGS OF
THE XXTH INTERNATIONAL CONFERENCE ON GAS
DISCHARGES AND THEIR APPLICATIONS

- VOLUME 1 -

6th - 11th July 2014
Orléans, FRANCE

Groupe de Recherches sur l'Energétique des Milieux Ionisés (GREMI)
Université d'Orléans
C.N.R.S

Editors: Prof. D. Hong
Dr. J.M. Bauchire
Dr. M. Mikikian
Dr. H. Rabat

GREMI UMR7344
14 rue d'Issoudun, BP 6744
45067 Orléans

EXECUTIVE MANAGEMENT COMMITTEE

Dr. J.E. Jones, Chair
Prof. A. Gleizes
Prof. G.R. Jones
Prof. S.J. MacGregor
Prof. J.W. Spencer

INTERNATIONAL SCIENTIFIC COMMITTEE

Dr. J.-M. Bauchire, France	Prof. Z. Petrovic, Serbia
Dr. J.-P. Borra, France	Prof. G.J. Pietsch, Germany
Prof. M. Fang, UK	Prof. V. Rakov, USA
Prof. M. Farzaneh, Canada	Dr. Ph. Robin-Jouan, France
Prof. C.M. Franck, Switzerland	Prof. A. Robledo-Martinez, Mexico
Prof. A. Gleizes, France	Prof. M. Rong, China
Prof. Z. Guan, China	Dr. M. Seeger, Switzerland
Prof. A. Haddad, UK	Prof. J.W. Spencer, UK
Dr. W. Hartmann, Germany	Dr. S. Stangherlin, Switzerland
Prof. K. Hidaka, Japan	Dr. T. Teich, Switzerland
Prof. D. Hong, France	Prof. J. -Y. Trepanier, Canada
Prof. G.R. Jones, UK	Dr. J.L. Walsh, UK
Dr. J.E. Jones, UK	Prof. K.-D. Weltmann, Germany
Prof. S.J. MacGregor, UK	Prof. Y. Wu, China
Dr. A.B. Murphy, Australia	Prof. M. Yumoto, Japan

LOCAL ORGANIZING COMMITTEE

GREMI

Dunpin Hong, Chair
Maxime Mikikian, Secretary
Jean-Marc Bauchire, Program chair
Hervé Rabat, Coordinator
Olivier Aubry
Christophe Cachoncinlle
Sébastien Dozias
Chantal Leborgne
Stéphane Pellerin
Eric Robert
Anne-Lise Thomann
and many other GREMI colleagues ...

CNRS

Linda Jeuffrault, Graphic designer

Office de Tourisme & de Congrès d'Orléans
Céline Gouineau
Marie-Catherine Mercier

DIAGNOSTICS OF LOW-PRESSURE RF OXYGEN PLASMA SUITABLE FOR TREATMENT OF SENSITIVE SURFACES

N. ŠKORO*, K. SPASIĆ, N. PUAC̆, G. MALOVIĆ AND Z. LJ. PETROVIĆ

¹Institute of Physics, University of Belgrade, Pregrevica 118, 11080, Belgrade, Serbia

*nskoro@ipb.ac.rs

ABSTRACT

We have created an asymmetric CCP plasma reactor that operates at 13.56 MHz for the purpose of large scale plasma treatment of sensitive samples such as textiles or seeds. In order to be able to optimise parameters for different treatments one should determine chemical composition of plasma in detail. Here we will present results obtained by optical actinometry that was used to determine concentration of oxygen atoms. In addition, mass spectrometry was used to estimate relative number of metastable and excited oxygen atoms and molecules.

1. INTRODUCTION

Due to relative simplicity of parameter control of low pressure plasmas they are widely used in industry for processes such as deposition and etching [1]. Plasma source that was developed in our laboratory is, due to its geometry, especially suitable for treatments of sensitive samples like textile, wool or seeds [2] as its asymmetry ascertains reduced energy of ions hitting the outer walls. When it comes to pre-treatment of seeds, plasma is an effective tool for improvement of germination and, also, an excellent sterilization agent [3]. With plasma treatment both problems could be solved simultaneously by choosing the correct set of treatment parameters for desired plasma chemistry.

Knowledge of active species produced in the plasma is required to plan its effects on materials. Especially important species for biomedical applications are radical oxygen species (neutral oxygen atoms, singlet delta oxygen molecules etc.) and oxygen ions. Optical actinometry was used in order to obtain absolute

concentrations of atomic oxygen in our plasma. This is a simple, non-intrusive experimental tool, but at the same time one should be aware of its limits [4, 5]. Here we will present results of integrated absolute density of atomic oxygen obtained for pressures of 300 mTorr and 450 mTorr for the range of powers from 200 W up to 500 W.

Since optical actinometry can give us information only about absolute concentrations of neutral oxygen atoms, we have used mass-energy analyser in order to obtain the relative number of excited and metastable oxygen species. For example one of the most important signal molecules and at the same time oxidants is the metastable state of oxygen molecule (${}^1\Delta_g\text{O}_2$) [6]. Apart from this molecule, excited and metastable oxygen atoms and ions also actively participate in plasma-biosurface interactions.

2. EXPERIMENTAL SETUP

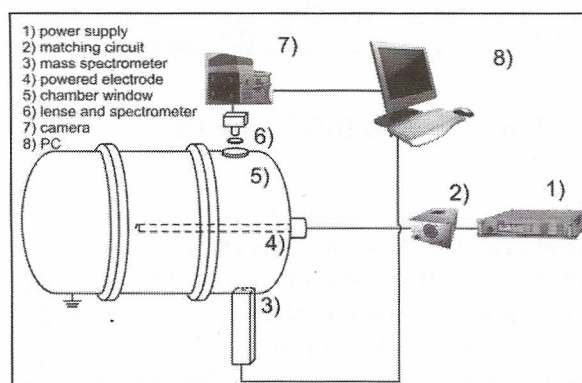

Fig. 1. Experimental setup

Diagnostics and treatments of sensitive samples were performed in RF plasma system that can be used for industrial applications if necessary. Power to this asymmetric capacitively coupled system operated at 13.56 MHz was supplied by Dressler Cesar 1310 through Variomatch

matching network (Fig. 1). Cylindrically shaped outer wall made of stainless steel served as grounded electrode. The reactor chamber was 2.5 m long and had a diameter of 1.17 m. Powered electrode was 1.5 m long aluminum rod (3 cm in diameter) placed along the central axis of the chamber.

Plasma emission in visible spectral range was recorded side-on through a window positioned at the level of the rod electrode. In focus of a lens, an entrance slit of monochromator Oriel MS127i was placed equipped with i-Star Andor ICCD camera as a detector. This way, the spectroscopic system recorded spatially integrated light coming from the region around electrode to the side window of the chamber. Recording time of the spectra was several hundred ms, so light emission from many RF periods was integrated. The emission intensity of two characteristic lines of oxygen (777 and 844 nm) and Ar (750 and 811 nm) were traced for different powers and pressures. Intensity ratios of 844 nm and 811 nm lines were used for actinometry calculations.

HIDEN EQP mass spectrometer was positioned side-on and the distance of the mass spectrometer orifice from the powered electrode was 30 cm. The number of oxygen atoms and molecules was measured as a function of electron energies coming from the filament of mass spectrometer. The range of electron energies covered was from 4 to 35 eV with resolution of 0.1 eV. Apart from neutrals we have measured energy distribution of O^+ ions. The working gas mixture was 99% of oxygen and 1% of argon, added as an actinometer gas.

3. RESULTS AND DISCUSSION

Optical emission measurements

Absolute densities of oxygen atoms can be determined from actinometry calculations by using optical emission intensity ratios of O and Ar atoms. Generally, for the intensity ratio to be proportional to the densities of excited species, conditions regarding cross section shape and thresholds as well as (de)excitation levels should be fulfilled [4]. Since these conditions are not generally satisfied in plasmas, utilization of the method for a particular experimental system depends on the evaluation of the conditions.

In case of oxygen, processes relevant for emission of O-844 nm line are direct and dissociative excitation, radiative decay and quenching of excited atoms. Rate coefficients for direct ($k(O)_{dir}$) and dissociative excitation ($k(O)_{dis}$) shown in Fig. 2 were calculated using emission cross sections from literature [7, 8] and assuming Maxwell distribution of electron energy. An error introduced to the rates by using Maxwell distribution function and disregarding cascading transitions is not larger than a factor of 2 [9]. Rate for direct excitation of oxygen atoms is more than 50 times higher than the rate for excitation through the dissociative channel at the temperature around 3 eV, which is the temperature of electrons obtained in our reactor. Rate coefficient for direct excitation of Ar ($k(Ar)_{dir}$) [10] is also shown (Fig. 2).

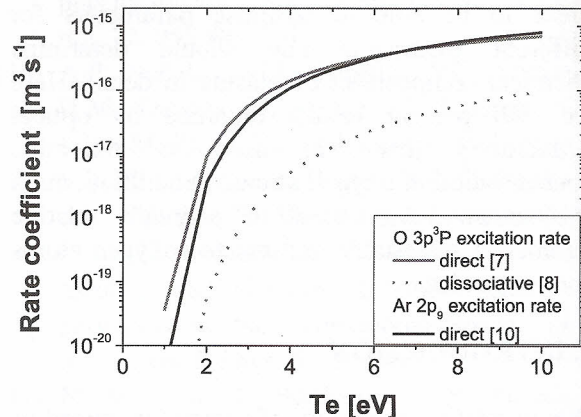

Fig. 2 Rate coefficients for direct excitation of Ar and O atoms (full lines) and dissociative excitation of O (dashed line)

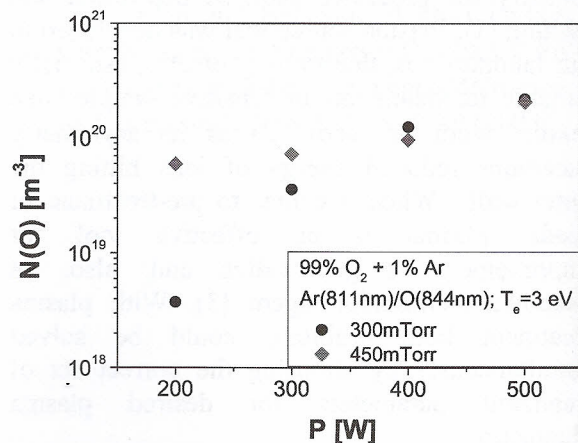

Fig. 3 Densities of oxygen atoms produced in 99% O₂ + 1% Ar plasma at 300 mTorr and 450 mTorr obtained from actinometry

All processes relevant for emission of O-844 nm and Ar-811 nm lines (I_O and I_{Ar}) are included in actinometry formula:

$$N_O = N_{Ar} \frac{I_O}{I_{Ar}} \gamma \frac{k_{Ar}^{dir}}{k_O^{dir}} - N_{O_2} \frac{k_O^{dis}}{k_O^{dir}} \quad (1)$$

with

$$\gamma = C_{em} \frac{A_{Ari}(\sum_j A_{Oj} + q_{O_2}^0 N_{O_2})}{A_{Oj}(\sum_i A_{Ari} + q_{O_2}^{Ar} N_{O_2})} \quad (2)$$

where coefficient C_{em} contains all calibration factors of the optical system, A_{Ari} and A_{Oj} are transition probabilities [11] and $q_{O_2}^X$ are coefficients for atom quenching with O_2 [12]. Stepwise excitations through metastable states were disregarded in this calculation.

In Fig. 3 we show densities of atomic oxygen calculated from actinometry measurements for two pressures: 300 mTorr and 450 mTorr. Densities of O rise steady with power for both pressures, starting from around $5 \cdot 10^{19} \text{ m}^{-3}$ and going up to $2.2 \cdot 10^{20} \text{ m}^{-3}$ at maximum power of 500 W. There is not much differences between densities obtained for two pressures in case of higher powers. For powers bellow 400 W the density of neutral oxygen atoms is lower at lower pressure.

Mass spectrometry measurements

Mass spectrometry can give us information about chemical composition of the plasma system and its behaviour depending on the type of measurements conducted. When measuring the composition of neutral molecules and atoms, ionisation takes place inside the ionisation source of mass-energy analyser. We have measured mass spectra of the plasma with the energy of the electrons in the ionisation source set to 70 eV. The most abundant molecule and atoms were O_2 and O. We detected small amount of nitrogen molecules and atoms due to only mechanical pumping that was used in experiment. From these measurements dissociation degree was estimated and in our case dissociation degree goes up to 1%. This result is in general agreement with the dissociation degree obtained by actinometry. Having said that we have to bear in mind that the two techniques average out properties differently, one throughout the system the other just samples in front of the orifice.

Number of oxygen atoms and molecules detected by the mass energy analyser is shown as a function of the energy of the electrons in ionization source (Fig 4). When plasma is not ignited, the signal for O atoms originates only from the dissociation of the oxygen molecules inside the ionisation source. In case when plasma is ignited, we can see that the signal for oxygen

atoms is obtained even for energies of electrons lower than dissociation threshold of O_2 (20 eV [14]) and ionisation threshold of O (13.6 eV [15]). This indicates that all these atoms, which can be ionised by the electrons with lower energy then the ionisation threshold, are entering ionisation source already in the excited or metastable state. The slight increase in the signal around 10 eV correspond to the two metastable states of O atom.

Similar measurements were made for the oxygen molecule. This molecule and its metastable states are very important in interaction of plasma with the cells - $^1\Delta_g O_2$ is recognized as one of the most important signal molecules and oxidant [6]. We can see that when plasma is ignited significant amount of molecules are detected below the threshold energy for ionisation of oxygen molecule (13 eV). As in case of oxygen atoms, this signal is obtained by ionisation of excited and metastable molecules coming from the plasma into the ionisation source. Slight increase in the signal can be observed around 12 eV and this can be attributed to the metastable state of O_2 ($^1\Delta_g O_2$).

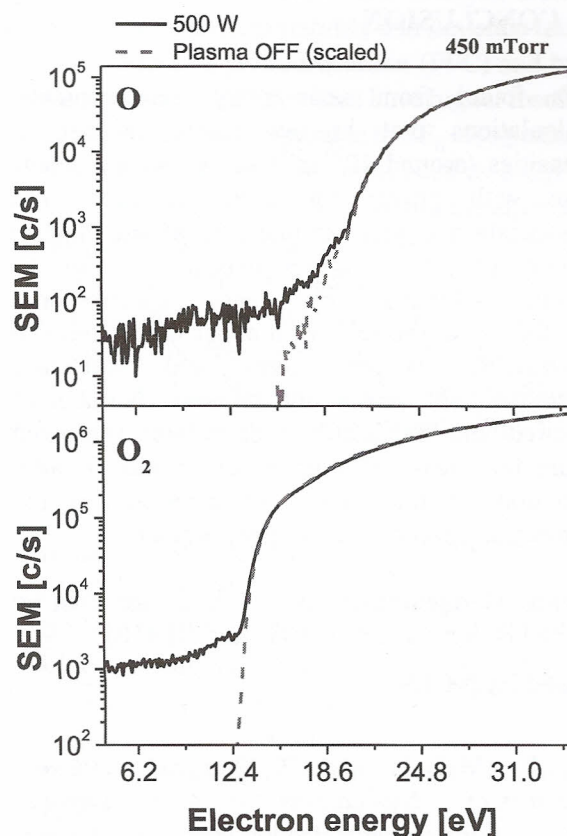

Fig. 4. Signals of O and O_2 as a function of the energy of the electrons in the ionisation source. Black curve represents signal when plasma is ignited (500W) and red one when there is no plasma. Pressure was 450 mTorr.

The relative number of excited and metastable oxygen atoms and molecules as a function of power is presented in Fig. 5. The values presented are obtained by integration of the recorder signal for the range of energies from 4 eV to 13.62 eV for oxygen atom and for the range 4-13 eV for O₂. We can see that number of excited and metastable atoms/molecules increases with power. Number of excited species increases with pressure.

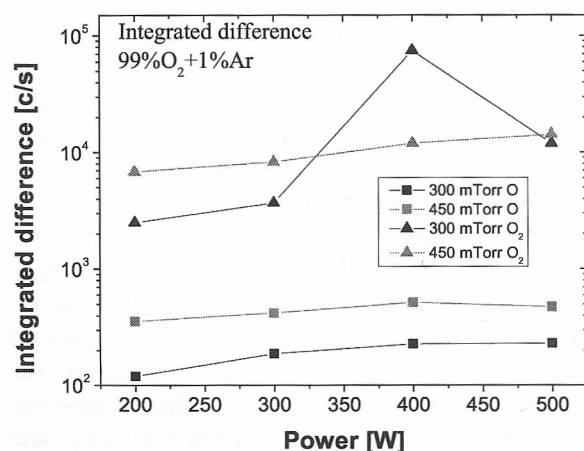

Fig. 5 Integrated difference of excited states count for atomic and molecular oxygen at 300 and 450 mTorr for various powers.

4. CONCLUSION

We found from actinometry measurements-calculations that in our reactor atomic O densities (around 10^{20} m^{-3}) show similar, steady rise with power for both pressures. The dissociation degree around 1% at the highest power of 500 W agrees reasonably with the results obtained by mass spectrometry. Furthermore, the relative number of excited and metastable oxygen atoms and molecules increases with power and pressure. Number of excited and metastable species was estimated from the measured number of O and O₂ as a function of the energy of electrons in the ionization source of mass spectrometer.

Acknowledgements: This work is supported by MESTD, Serbia, ON 171037 and III 41011.

REFERENCES

[1] T. Makabe and Z Petrovic, "Plasma Electronics: Applications in Microelectronic Device Fabrication", Taylor & Francis Group, LLC, 2006
 [2] M. Gorenšek, M. Gorjanc, V. Bukošek, J. Kovač, Z. Petrović and N. Puač,

"Functionalization of Polyester Fabric by Ar/N₂ Plasma and Silver", Text. Res. J., **80**, 1633-1642, (2010)

[3] I. Filatova, V. Azharonok, V. Lushkevich, A. Zhukovsky, G. Gadzhieva, K. Spasić, S. Živković, N. Puač, S. Lazović, G. Malović and Z.Lj.Petrović, "Plasma seeds treatment as a promising technique for seed germination improvement", 31st ICPIG, 2013

[4] R. E. Walkup, K. L. Saenger, and G. S. Selwyn, "Studies of atomic oxygen in O₂+CF₄ rf discharges by two-photon laser-induced fluorescence and optical emission spectroscopy", J. Chem. Phys., **84**, 2688, 1986

[5] S. B. Radovanov, B. Tomčik, Z. Lj. Petrović, and B. M. Jelenković, "Optical emission spectroscopy of rf discharge in SF₆", J. Appl. Phys., **67**, 97, 1990

[6] J. M. Matés, "Effects of antioxidant enzymes in the molecular control of reactive oxygen species toxicology", Toxicology **153**, 83, 2000

[7] L. L. Laher and F. R. Gilmore, "Updated Ecitation and ionization Cross Sections for Electron Impact on Atomic Oxygen", J. Phys. Chem. Ref. Data, **19**, 277, 1990

[8] M. B. Schulman, F. A. Scharpton, S. Chung, C. C. Lin and L. W. Anderson, "Emission from oxygen atoms produced by electron-impact dissociative excitation of oxygen molecules" Phys. Rev. A, **32**, 2100, 1985

[9] N. C. M. Fuller, M. V. Malyshev, V. M. Donnelly and I. P. Herman, "Characterization of transformer coupled oxygen plasmas by trace rare gases-optical emission spectroscopy and Langmuir probe analysis" Plasma Sourc. Sci. Tech., **9**, 116-127, 2000

[10] J. E. Chilton, J. B. Boffard, R. S. Schappe and C. C. Lin, "Measurement of electron-impact excitation into the 3p54p levels of argon using Fourier-transform spectroscopy", Phys. Rev. A, **57**, 267, 1998

[11] <http://www.nist.gov/pml/data/asd.cfm>

[12] Dagdigian P, Forch B E and Miziolek A W, "Collisional transfer between and quenching of the 3p 3P and 5P states of the oxygen atom", Chemical Physics Letters, **148**, 299, 1988

[13] Yukikazu Itikawa, "Cross Sections for Electron Collisions with Oxygen Molecules", J. Phys. Chem. Ref. Data, **38**, 1, 2009

[14] Y. Itikawa and A. Ichimura, "Cross sections for collisions of electrons and photons with atomic oxygen", J. Phys. Chem. Ref. Data, **19**, 3, 1990



27th Summer School and International Symposium on the Physics of Ionized Gases

August 26-29, 2014, Belgrade, Serbia

CONTRIBUTED PAPERS

&

**ABSTRACTS OF INVITED LECTURES,
TOPICAL INVITED LECTURES, PROGRESS
REPORTS AND WORKSHOP LECTURES**

Editors:

Dragana Marić

Aleksandar R. Milosavljević

Zoran Mijatović



Institute of Physics, Belgrade
University of Belgrade



Serbian Academy
of Sciences and Arts

**27th Summer School and International
Symposium on the Physics of Ionized
Gases**

SPIG 2014

CONTRIBUTED PAPERS

&

ABSTRACTS OF INVITED LECTURES,
TOPICAL INVITED LECTURES, PROGRESS REPORTS
AND WORKSHOP LECTURES

Editors

Dragana Marić, Aleksandar R. Milosavljević and
Zoran Mijatović

Institute of Physics, Belgrade
University of Belgrade

Serbian Academy
of Sciences and Art

Belgrade, 2014

CONTRIBUTED PAPERS & ABSTRACTS OF INVITED
LECTURES, TOPICAL INVITED LECTURES, PROGRESS
REPORTS AND WORKSHOP LECTURES
of the 27th Summer School and International Symposium on
the Physics of Ionized Gases

August 26 – 29, 2014, Belgrade, Serbia

Editors:

Dragana Marić, Aleksandar R. Milosavljević and Zoran Mijatović

Publishers:

Institute of Physics, Belgrade
Pregrevica 118, P. O. Box 68
11080 Belgrade, Serbia

Klett izdavačka kuća d.o.o.
Maršala Birjuzova 3-5, IV sprat
11000 Belgrade

Computer processing:

Sanja D. Tošić, Nikola Škoro and Miloš Ranković

Printed by

CICERO
Belgrade

Number of copies

300

ISBN 978-86-7762-600-6

©2014 by the Institute of Physics, Belgrade, Serbia and Klett izdavačka kuća d.o.o. All rights reserved. No part of this book may be reproduced, stored or transmitted in any manner without the written permission of the Publisher.

ACKNOWLEDGEMENT

27th SUMMER SCHOOL AND INTERNATIONAL SYMPOSIUM ON THE PHYSICS OF IONIZED GASES

is organized by the

**Institute of Physics, Belgrade
University of Belgrade
Serbia**

and

**Serbian Academy of
Sciences and Arts**

under the auspices and with the support of the

**Ministry of Education, Science and Technological Development,
Republic of Serbia**

with the technical support of the
PANACOMP - Zemlja Čuda d.o.o.

and sponsored by:

**SOLEIL synchrotron
RoentDek Handels GmbH
Klett izdavačka kuća d.o.o.
Springer (EPJD and EPJ TI)
IoP Publishing (IoP Conference Series)
DEA club
Austrijski kulturni forum (Kulturforum Belgrad)
Institut français de Serbie
Balassi Institute – Collegium Hungaricum Beograd**

SPIG 2014

SCIENTIFIC COMMITTEE

Z. Mijatović (Chair), Serbia
S. Buckman, Australia
J. Burgdörfer, Austria
M. Danezis, Greece
Z. Donko, Hungary
V. Guerra, Portugal
M. Ivković, Serbia
D. Jovanović, Serbia
K. Lieb, Germany
I. Mančev, Serbia
D. Marić, Serbia
N. J. Mason, UK
A. R. Milosavljević, Serbia
K. Mima, Japan
Z. Mišković, Canada
B. Obradović, Serbia
G. Poparić, Serbia
L. C. Popović, Serbia
Z. Rakočević, Serbia
Y. Serruys, France
N. Simonović, Serbia
M. Škorić, Japan
M. Trtica, Serbia

ADVISORY COMMITTEE

D. Belić
N. Bibić
M. S. Dimitrijević
S. Đurović
N. Konjević
J. Labat
B. P. Marinković
M. Milosavljević
Z. Lj. Petrović
J. Purić
B. Stanić

ORGANIZING COMMITTEE

Institute of Physics Belgrade

D. Marić (Co-chair)
A. R. Milosavljević (Co-chair)
S. D. Tošić (Co-Secretary)
N. Škoro (Co-Secretary)
B. P. Marinković
M. Cvejić
J. Sivoš
K. Spasić
M. Ranković

Serbian Academy of Sciences and Arts

Z. Lj. Petrović
M. Ivanović

SPIG 2014 CONFERENCE TOPICS

Section 1.

ATOMIC COLLISION PROCESSES

- 1.1. Electron and Photon Interactions with Atomic Particles
- 1.2. Heavy Particle Collisions
- 1.3. Swarms and Transport Phenomena

Section 2.

PARTICLE AND LASER BEAM INTERACTION WITH SOLIDS

- 2.1. Atomic Collisions in Solids
- 2.2. Sputtering and Deposition
- 2.3. Laser and Plasma Interaction with Surfaces

Section 3.

LOW TEMPERATURE PLASMAS

- 3.1. Plasma Spectroscopy and Other Diagnostics Methods
- 3.2. Gas Discharges
- 3.3. Plasma Applications and Devices

Section 4.

GENERAL PLASMAS

- 4.1. Fusion Plasmas
- 4.2. Astrophysical Plasmas
- 4.3. Collective Phenomena

ION ENERGY DISTRIBUTION AND LINE INTENSITIES IN ASYMMETRICAL OXYGEN RF DISCHARGE

Kosta Spasić, Nikola Škoro, Nevena Puač, Gordana Malović and
Zoran Lj. Petrović

*Institute of Physics, Pregrevica 118, 11080 Belgrade, Serbia,
Belgrade University*

Abstract. Asymmetric 13.56 MHz CCP plasma reactor of large area was developed for purpose of continuous plasma treatment of sensitive samples like polymers, textile and seeds. In order to maximize efficiency of plasma treatment and to get well acquainted with relevant plasma chemistry, plasma diagnostic by using mass spectrometer and optical emission recordings was performed. Supplied RF power was from 100 W to 600 W at 600 mTorr pressure of O₂ with 1% of Ar gas mixture. Distribution of O₂⁺ ions had much higher counts than O⁺ and for both species higher power resulted in more available high energy ions. Emission spectroscopy revealed an increase in oxygen 777 nm and argon 750 nm line intensity with the increase of power.

1. INTRODUCTION

In everlasting struggle for energetic efficiency and always needed cost reduction, numerous industries can find their solution in applications of low pressure plasmas. We have already shown some benefits for agriculture, because plasma treated seeds have higher germination rate and, in some cases, plants whose seed was treated develop significantly faster [1-3]. It is also important to emphasize possibility to use plasma as sterilization agent [1-3]. Positive effects of this technology are of great importance in textile industry [4], where they can improve quality of products and decrease ecological impact. Low pressure plasmas are used in various large scale industries, in processes like etching and deposition, where any reduction in used energy can make them more cost effective and environmentally friendly

Investigation of role of ions in plasma chemistry is of paramount importance both for general science and for industrial applications. In this paper we present measurements of ion energy distributions for singly ionized molecule and atom of oxygen (32 and 16 amu). Moreover, we have employed optical emission spectroscopy (OES) to obtain information about relevant lines of O and Ar.

2. EXPERIMENT

Large volume asymmetric CCP plasma reactor was developed as a prototype for industrial scale treatment of sensitive samples. Its asymmetric geometry allows stable plasmas to be formed without possibility of streamer formation. Stainless steel cylindrical chamber, 2.5 m in length and 1.17 m in width, serves as grounded electrode, while powered electrode is 1.5 m long axially placed aluminum rod (3 cm in diameter). Power is supplied at 13.56 MHz by Dressler Cesar 1310 supply through Variomatch matching network.

Spectrally resolved emission from plasma was recorded in a part of visible spectrum (720-790 nm) through a side window positioned at level of the rod electrode. We have used monochromator Oriel MS127i with i-Star Andor ICCD camera as detector. By using a lens at the entrance slit, the spectrometer collected all light originating from the part of the plasma volume at the side-on region of the electrode. Recording time of several hundred ms contains integrated light emission from many RF periods. Two characteristic lines for atomic oxygen (777 nm) and argon (750 nm) were traced at different powers

HIDEN EQP mass spectrometer was positioned side-on and the distance of the mass spectrometer orifice from the powered electrode was 30 cm. The orifice of the mass spectrometer was at ground potential. Ion energy distribution was measured for energies between 4 and 100 eV with resolution of 0.1 eV. The working gas mixture was 99% of oxygen and 1% of argon at a pressure of 600 mTorr which is suitable for treatments. Measurements were done in the range of powers from 100 to 600 W.

3. RESULTS AND DISCUSSION

In Fig. 1 a) we have presented ion energy distributions for positive ions of molecular oxygen (O_2^+) recorded at 600 mTorr for powers 400, 500 and 600 W. For powers lower than 400 W we could not obtain valid signal of ion energy distributions. At 400 W maximum ion counts can be observed at 4 eV and after that distribution rapidly decreases 5 orders of magnitude. For this power given by RF power supply maximum of ion energy is around 20 eV. With the increase of the power we can see that ions with higher energies can be collected. For the power of 500 W maximum ion energy goes up to 70 eV and for 600 W this energy is higher than 100 eV.

Situation is somewhat similar for distribution of singly ionized atomic oxygen (O^+) shown in Fig. 1 b). However, in case of O^+ we can see two peaks present for the powers of 400 and 500 W. In case of 600 W we can only assume that there is the second peak around 100 eV since the signal started to increase at around 90 eV.

Notwithstanding that we could not obtain valid ion signal for the powers lower than 400 W, plasma was ignited for the lower powers. In order to investigate if there is some change in plasma behavior at 400 W we have performed OES and recorded oxygen and argon line intensities.

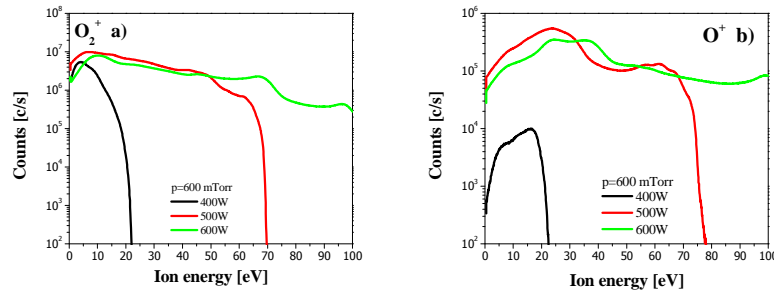

Figure 1. Ion energy distributions of O_2^+ (a) and O^+ (b), recorded at 600 mTorr for three different powers given by RF power supply.

Measurements of line intensity dependence for two oxygen and argon lines are shown in Fig. 2 for different powers (full symbols). Line intensities are relatively scaled and show similar intensities and rising tendency with power increase. For both lines the increase in intensity is larger, almost exponential, at higher powers. Additionally, the ratio between obtained line intensities is shown in the right-hand-side axis (crosses) and exhibits small increase with power. Also, interesting observation is that at 400 W there is decrease in line intensity ratio.

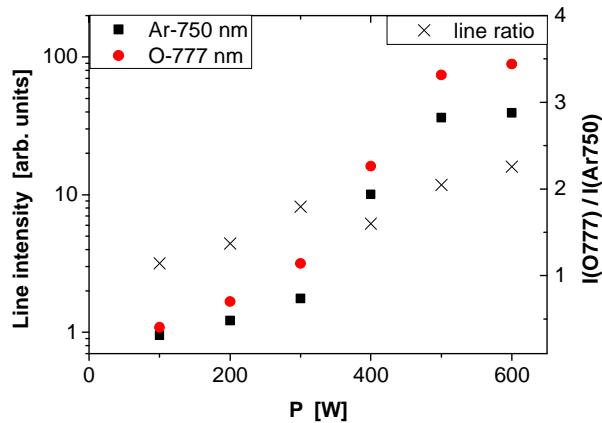

Figure 2. Left axis: oxygen 777 nm (circles) and argon 750 nm (squares) line intensities, right axis: line intensity ratio (crosses) at different powers at 600 mTorr.

Generally, in cases where emission originating from dissociative excitation is not dominant, the line intensity ratio could be used for an estimation of the dissociation extent in plasma through a method of optical actinometry [5]. However, in plasmas with low dissociation extent and where dissociative excitation channel is dominant, results of actinometry can provide only qualitative description of change in oxygen dissociation with plasma parameters

[6,7]. Thus, in this case the intensity ratio provides only general trend in dissociation of oxygen.

4. CONCLUSION

We have measured ion energy distribution and performed spectroscopic measurements of large volume asymmetric CCP plasma reactor. No valid ion signal could be detected at powers lower than 400 W, and even at that power distribution reaches minimal values at just over 20 eV. With increased RF powers, we were able to detect ions at energies higher than 100 eV. Optical emission spectroscopy, in this range of plasma parameters, could only provide us with general information that dissociation of oxygen molecules is rising with powers.

Acknowledgements

This research is supported by the Serbian Ministry of Education, Science and Technological Development under project numbers ON171037 and III41011.

REFERENCES

- [1] I. Filatova, V. Azharonok, V. Lushkevich, A. Zhukovsky, G. Gadzhieva, K. Spasić, S. Živković, N. Puač, S. Lazović, G. Malović, Z.Lj.Petrović, “*Plasma seeds treatment as a promising technique for seed germination improvement*”, (31st ICPIG, 2013).
- [2] N. Puač, Z. Lj. Petrović, S. Živković, Z. Giba, D. Grubišić, A. R. Djordjević, *Plasma Process Polym*, pp 193 (2005).
- [3] I. I. Filatova, V. V. Azharonok, S. V. Goncharik, V. A. Lushkevich, A. G. Zhukovsky, G. I. Gadzhieva, *J Appl Spectrosc*, 81 2 250 (2014).
- [4] M. Gorenšek, M. Gorjanc, V. Bukošek, J. Kovač, Z. Petrović, N. Puač, *Text. Res. J.* 80, 1633, (2010).
- [5] J. W. Cobrun, M. Chen, *J. Appl. Phys.* 51, 3134 (1980).
- [6] H. M. Katsch, A. Tewes, E. Quandt, A. Goehlich, T. Kawetzki, H. F. Doebele, *J. Appl. Phys.* 88 6232 (2000).
- [7] L. Zhongwei, L. Sen, C. Qiang, Y. Lizhen, W. Zhengduo, *Plasma Sci Technol*, 13 458 (2011).



ICPIG 2015

XXXII INTERNATIONAL CONFERENCE ON PHENOMENA IN IONIZED GASES

26-31 July ■ IAȘI ■ ROMANIA

www.icpig2015.net

loc@icpig2015.net



Professor Laifa BOUFENDI
President of the ISC

Professor Gheorghe POPA
Chair of LOC

COMMITTEES

International Scientific Committee

Laifa BOUFENDI, *President of ISC*

Université d'Orléans, France

France and North Africa

Miles TURNER

Dublin City University Ireland

UK and Ireland

Yi Kang PU

Tsinghua University, China

Mainland China, Taiwan and Korea

Eugen STAMATE

Technical University of Denmark, Denmark

Norway, Sweden, Finland and Denmark

Sudeep BHATTACHARJEE

Indian Institute of Technology, Kanpur, India

Australia, New Zealand, Indonesia,
Polynesia, India and South Africa

Eduard SON

Joint Institute for High temperature RAS, Russia

Russia and the area of the former SU

Mark KUSHNER

University of Michigan, USA

USA and Canada

Jaime de URQUIJO

Instituto de Ciencias Físicas, UNAM, Mexico

Spain, Portugal, Mexico and South and
Central America

Masaru HORI

Nagoya University, Japan

Japan

Gheorghe POPA, *LOC Chair*

Alexandru Ioan Cuza University of Iasi, Romania

Bulgaria, Romania, Serbia, Bosnia,
Montenegro, Croatia and Slovenia

Olga DE PASCALE

CNR Institute of Inorganic Methodologies and
Plasmas, Italy

Italy, Greece and Israel

Holger KERSTEN

Kiel University, Germany

Germany, Austria, Lichtenstein and
Switzerland

Ute EBERT

Center for Mathematics and Computer Science
(CWI), Amsterdam, The Netherlands

Belgium, The Netherlands and
Luxembourg

Zdenko MACHALA

Comenius University, Bratislava, Slovakia

Poland, Hungary, Czech Republic and
Slovakia

Local Organizing Committee

Gheorghe POPA, LOC Chair	Alexandru Ioan Cuza University of Iași
Nicolae Victor ZAMFIR	IFIN-HH Bucharest
Gheorghe DINESCU	INFLPR Bucharest
Claudiu COSTIN, LOC Secretary	Alexandru Ioan Cuza University of Iași

LOC Members from Alexandru Ioan Cuza University of Iași

Cătălin AGHEORGHIESEI	Valentin POHOAȚĂ
Silvia-Alina CHIPER	Sebastian POPESCU
Alexandra DEMETER	Ioana-Alexandra RUSU
Marius DOBROMIR	Bogdan-George RUSU
Nicoleta DUMITRAȘCU	Florentina SAMOILĂ
Roxana JIJIE	Lucel SÎRGHI
Dumitru LUCA	Teodora TESLARU
Ilarion MIHĂILĂ	Vasile TIRON
Andrei-Vasile NĂSTUȚĂ	Ionuț TOPALĂ



Characterization of a large-volume Oxygen RF discharge suitable for low-pressure treatment of sensitive samples

K. Spasić¹, N. Puač¹, N. Škoro, G. Malović and Z.Lj. Petrović

¹*Institute of Physics, Belgrade University, Pregrevica 118, 11000 Belgrade, Serbia*

We have created plasma reactor that is prototype of a commercial device for industrial applications, in order to enable large scale treatment of sensitive samples. Strong asymmetry of electrodes and large volume are suitable for achieving streamer free and generally mild plasma. In order to optimize treatment conditions and make them as energy efficient as possible plasma characterization has to be performed. For that purpose we have used mass energy analyzer, optical emission spectrometry and actinometry in an oxygen-argon plasma at pressures of 300, 450, and 600 mTorr with applied powers between 100 and 700 W.

1. Introduction

Applications of low pressure plasmas are distributed over wide range of industries, mostly for processes such as etching and deposition. This is understandable if one bears in mind that they are easily controllable and fairly cheap to use [1]

The effect of non-equilibrium plasmas are also well-known and used in fields such as medicine and biology [2,3,4,5]. It is shown that after being exposed to gas discharges some seeds may improve their germination rate [6,7,8]. Effects can be noticeable even when seeds start to sprout since treated seedlings grow faster than those which were not treated [9]. Some seeds, usually due to bad storage conditions, can be infected with malignant bacteria and fungi that can affect their germination rate and growth. If that happens, plasma can be used for pre-saw sterilization, but discharge conditions have to be carefully set to avoid damage of seeds.

Having that in mind, a large scale plasma reactor, which can be used for treatment of sensitive samples, have been constructed in our laboratory. So far, it has been used for treatment of both seeds and textile [10,11].

Getting well acquainted with plasma chemistry and the ability to tune plasma parameters of the discharge that is used for treatments is very important in order to make it as effective and energy efficient as possible. For that purpose we have used mass-energy spectrometry, optical emission spectrometry and actinometry.

2. Experimental set-up

In order to provide a device for industrial scale treatment of sensitive samples, we have created large volume plasma reactor with asymmetric electrodes. It is 2.5 m long cylinder with the diameter of 1.17 m. Powered electrode is made of

aluminum and it is placed along central axis of reactor. The cylindrical electrode is 1.5 m long and 3 cm in diameter. Chamber wall serves as a grounded electrode. Samples are placed on a flat metal platform lying at the bottom of the chamber below the powered electrode. Power is supplied via matching box at 13.56 MHz by Dressler Cesar 1310 power supply that can deliver up to 1000 W. Due to the fact that electrode surface ratio is very big we can accomplish plasma conditions that are streamer free and hence suitable for treatment of samples that cannot withstand high currents or temperatures.

Gases are introduced over two separate lines, each controlled by a flowmeter, while two mechanical pumps were used to achieve and maintain vacuum. Oxygen and argon are mixed at the ratio of 99:1. Total flows were set to 110 sccm for 300 mTorr, 200 sccm for 450 mTorr and 290 sccm for 600 mTorr.

Mass-energy analyzer, HIDEN EQP, was placed side-on into the chamber. Its orifice is positioned at a fixed distance of 30 cm from the powered electrode. Energy of ionizing electrons emanating from the hot filament, which are required for detection of neutral species, can be controlled with resolution of 0.1 eV, starting from 4 eV. Number of neutral atoms or molecules can be measured as a function of energy of these electrons.

In a single scan, measurements performed at low power have very low signal. Therefore, we had low signal to noise ratio. In order to increase precision, 12 measurements were performed for each condition in accumulation mode resulting in a significant signal to noise improvement.

Optical emission spectra were obtained by using Oriel MS127i monochromator coupled with an ICCD camera. The spectrometer was positioned end-on, with a focusing lens collecting light along

axis of the vessel at two different levels: at the electrode level, facing the electrode tip, and at the platform level, 40 cm below the electrode. Since spectra recording times were several hundred ms, time and space integrated light emission was obtained in visual spectral range. Experimental set-up and positioning of the measurement equipment is shown in Figure 1.

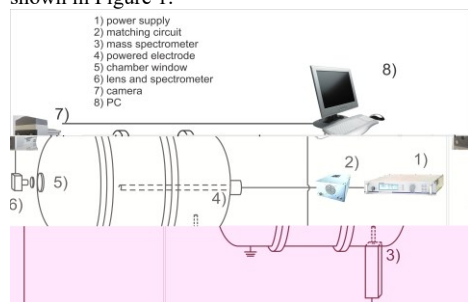

Figure 1. Experimental set-up schematics where devices are numbered as: 1) power supply, 2) matching box, 3) Mass spectrometer, 4) powered electrode, 5) chamber window, 6) lens and spectrometer, 7) camera and 8) PC.

3. Results

3.1. Mass spectroscopy

Mass spectroscopy is an indispensable tool for analyzing plasma sources. We have measured counts of oxygen molecules as a function of energy of ionizing electrons from the ionizer of the mass-energy analyzer. Measurements were performed at three different pressures: 300, 450 and 600 mTorr. Typical results are shown in **Figure 2**.

Oxygen molecules are of great interest due to their role in biochemical pathways in cells. Especially important signal molecule is O_2^- that is, among other places in cell, created at the cell membrane by ionizing O_2 metastable. In oxygen plasma we have a rich environment for this kind of reaction due to the presence of excited species and metastables. One should be aware that one of the most abundant metastables of oxygen the $O_2(a^1\Delta_g)$ state has threshold energy below 1 eV and thus the extension of the signal below 5 eV of the electron energy in Fig. 2 is not surprising. With power set to 0W (plasma not ignited) we can see only those molecules which were ionized inside mass spectrometer. Only neutral oxygen molecules in ground state are present. Therefore nothing is detected below the ionization energy which is 12.3 eV [12]. When discharge is turned on, a lot of molecules are detected below the threshold energy because, when they reach mass-energy analyzer

from plasma, they are already in excited or in metastable state. Signal obtained from these molecules can be seen in Figure 2 for the electron energies below the threshold. The fact that signal below threshold decreases with increasing power probably means that the reduction is due to electron quenching of metastables and increasing electron density with power.

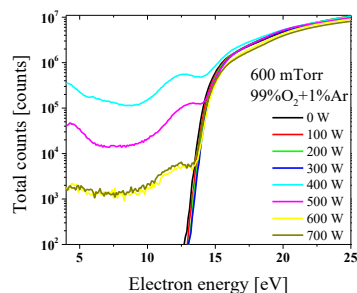

Figure 2. Counts of oxygen molecules, recorded as a function of electron energy at 600 mTorr at powers ranging from 0 to 700 W.

By integrating one curve up to the energy of 12 eV, we can get total number of molecules that are excited in the plasma and that arrived at the orifice of mass energy analyzer in excited/metastable state. We have chosen 12 eV as the limit for integration in order to be safely below the ionization threshold. Summarized results for excited and metastable oxygen molecules are shown in Figure 3.

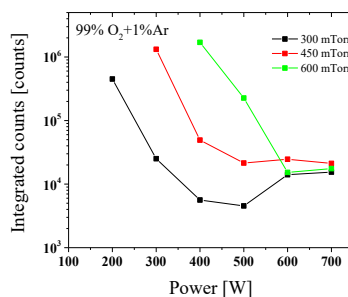

Figure 3. Counts of oxygen molecules integrated from device limit to ionization energy, recorded at various powers at pressures of 300, 450 and 600 mTorr

For all pressures that we used in these experiments plasma ignites for powers lower than 10 W. On the other hand, due to the large volume and cylindrical geometry of our reactor we have a range of power and pressure dependent conditions

when excited and metastable molecules could not be detected by mass spectrometer for present position of the orifice. In order to obtain the signal below the ionization threshold of O₂ more power has to be supplied to the system at higher pressures. Thus there appears to be a considerable loss of excited species between the active region of the plasma and the orifice of the mass analyzer especially at higher pressures. In addition there is a relative depletion towards the higher powers which may be associated by further excitation/ionization of the excited species.

We can see in Figure 3 that maximum counts are recorded at the lowest powers for each pressure. With the increase in applied power we observe the decrease in counts. At all three pressures we have a minimum that is a few orders of magnitude lower. For the highest powers there is an increase in the total counts up to the plateau that is common for all pressures.

3.2. Optical emission spectra and actinometry

In order to check the density of excited atomic oxygen species we recorded optical emission spectra of the discharge in the visual and near IR range for three different pressures and powers from 100 to 700 W. In figure 4 part of the spectrum between 740 – 850 nm is shown with characteristic atomic and molecular lines marked. The strongest lines in this wavelength range belong to O atoms produced in the discharge. Emission band coming from oxygen molecule is also present. Additionally, due to the admixture of 1% Ar, weak Ar lines are also visible.

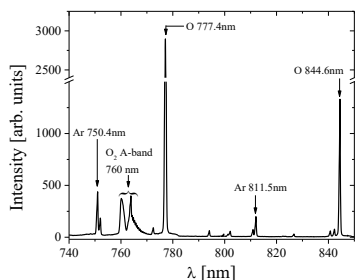

Figure 4. Part of the visual emission spectrum of O₂/Ar discharge at 200 W and 450 mTorr with characteristic oxygen and argon lines labeled in the plot

Addition of a small amount of Ar allowed us to use optical actinometry – simple and straightforward technique for determining concentration of neutral

species in low-pressure plasmas [13]. Employing this technique, ratio of the observed emission intensities for selected transitions from the upper excited atomic states of oxygen and argon can be related to the concentration ratio of ground states of these atoms.

Main assumption in actinometry is that emitter atoms are excited from the ground state in collisions with electrons. However, with atomic O lines in some cases, large extent of emission could originate from dissociative excitation and not from direct atom excitation [14]. Thus, in principle, dissociative excitation has to be taken into account as well as all other important excitation (through metastables, three-body collisions etc.) and de-excitation (spontaneous emission, quenching) channels [15,16]. In our calculations, contribution of the dissociative excitation has been included.

Using appropriate rate coefficients (k) [17], spectroscopic constants (transition probabilities, geometric constants: $C(\lambda_{Ar})$, $C(\lambda_O)$) and measured line intensities (I_O , I_{Ar}) the dissociation degree of oxygen is calculated as:

$$x = \left(\frac{N_{Ar}}{N_{O_2}^0} \frac{I_O}{I_{Ar}} \gamma \frac{k_{Ar}^{dir}}{k_O^{dir}} - \frac{k_O^{dis}}{k_O^{dir}} \right) / \left(2 - \frac{k_O^{dis}}{k_O^{dir}} \right) \quad (1)$$

where

$$\gamma = \frac{C(\lambda_{Ar})\lambda_O A_{Arp} (\sum_j A_{Oji})}{C(\lambda_O)\lambda_{Ar} A_{Oj} (\sum_p A_{Arpq})}$$

In numerator of equation (1) the first term represents contribution of direct excitation and the second one describes dissociative excitation channel. For calculations we used rate coefficients obtained assuming Maxwell distribution of electron energy and mean electron energy of 3 eV.

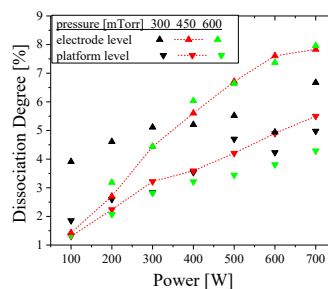

Figure 5. Dissociation degree of O₂/Ar discharge at 300, 450 and 600 mTorr calculated by using actinometry

formula and emission line intensities (O-844 nm, Ar-811 nm) obtained at two different window positions.

In figure 5 we show the extent of O₂ dissociation at three different pressures calculated by using data of oxygen 844 nm and Ar 811 nm lines obtained for two different positions of the spectrometer. The spectra were recorded for discharge conditions (pressure and power) at two windows placed at different positions with the respect to the central cylinder axis. The first one, in the center, **opposite** to the very bright volume around the electrode (marked as electrode level in the plot) and the other, at the platform level, close to the wall of the reactor (marked as platform level). Due to small size of the windows, emission of the lines recorded at these positions mostly originates from the volumes lengthwise the reactor facing the appropriate window.

At low powers, the dissociation degree is similar for all pressures and at both window levels. As power increases, number of dissociative products grows steadily at all pressures and for both positions. Degree of dissociation in the central region around the electrode increases much faster comparing to the degree obtained away from the electrode, at the platform level. At maximum power of 700 W the degree of dissociation reaches 8% in the region around electrode while at the platform it is around 5%. Variation of the dissociation degree for different pressures is small and almost within error bars of the technique.

From equation (1) we were able to estimate contribution of the dissociation excitation channel to the calculation of dissociation degree. For the data obtained at platform level, we estimate that dissociative excitation contributes up to 30% of the O atom emission at lowest powers while it decreases to 15% with increasing power. At the electrode level, this contribution is lower than 20% at lower powers and around 10% at the highest power.

3. Conclusion

We have used mass-energy analyzer to measure counts of oxygen molecules as a function of energy of ionizing electrons in 99% oxygen and 1% argon plasma. It is shown that the highest presence of excited and metastable oxygen molecules is obtained for minimum power in the range where signals are observable, at every pressure. Also, maximum counts are moving to higher powers at higher pressures. Optical actinometry measurements enabled us to determine dissociation degree of oxygen molecules in zone around the electrode and at the platform level. At both levels dissociation is

rising with power and this increase is more pronounced near the powered electrode. The dissociation degree obtained from the space-time integrated measurements is in the range between 1 and 8 % and it has a very weak pressure dependence between 300 mTorr and 600 mTorr.

[1] T. Makabe and Z. Lj. Petrovic, *PLASMA ELECTRONICS: Applications in Micro Electronic Device Fabrication*, Taylor & Francis Group, (2006)

[2] K. Kutasi, B. Saoudi, C.D. Pintassilgo, J. Loureiro, M. Moisan, *Plasma Processes and Polymers*, **5** (2008) 840

[3] R.J. Reece, D.M. Sherman, R.B. Gadri, F. Karakaya, Z. Chen, T.C. Montie, K.W. Kimberly, and PP-Y. Tsai, *Plasma Science, IEEE Transactions on* **28** 1 (2000) 56

[4] G. Fridman et al, *Plasma Processes and Polymers Special Issue: Special Issue on Plasma Medicine*, **5** 6 (2008) 503

[5] M. Laroussi, M. Kong, G. Morfill and W. Stolz, *Plasma Medicine: applications of low-temperature gas plasmas in medicine and biology*, University Press, Cambridge (2012)

[6] S. Živković, N. Puač, Z. Giba, D. Grubišić, Z.Lj. Petrović, *Seed Science and Technology*, **32** 3 (2004) 693

[7] N. Puač, Z.Lj. Petrović, S. Živković, Z. Giba, D. Grubišić and A.R. Đorđević, *Low-Temperature Plasma Treatment of Dry Empress-Tree Seeds*, in *Plasma Processes and Polymers*, Wiley-VCH Verlag GmbH & Co. KGaA (2005)

[8] I. Filatova, V. Azharonok, V. Lushkevich, A. Zhukovsky, G. Gadzhieva, K. Spasić, S. Živković, N. Puač, S. Lazović, G. Malović and Z.Lj.Petrović, *31st ICPIG* (2013)

[9] I. Filatova, V. Azharonok, E. Gorodetskaya, L. Mel'nikova, O. Shedikova, and A. Shik, *19th ISPC* (2009) 26

[10] S. Živković, N. Puač, Z. Giba, D. Grubišić, Z.Lj. Petrović, *Seed Science and Technology*, **32** 3 (2004) 693

[11] N. Puač, Z.Lj. Petrović, M. Radetić, A. Djordjević, *Materials Science Forum* **494** (2005) 494

[12] J. T. Gudmundsson and E. G. Thorsteinsson, *Plasma Sources Sci. Technol.* **16** (2007) 399

[13] J. W. Coburn, M. Chen, *J. Appl. Phys.* **51** (1980) 3134

[14] H. M. Katsch, A. Tewes, E. Quandt, A. Goehlich, T. Kawetzki, H. F. Doebele, *J. Appl. Phys.* **88** (2000) 6232

- [15] L. Zhongwei, L. Sen, C. Qiang, Y. Lizhen, W. Zhengduo, *Plasma Sci Technol* **13** (2011) 458
- [16] S. Radovanov, B. Tomčik, Z. Lj. Petrović, B.M. Jelenković, *J. Appl. Phys.* **67** 1 (1990) 97
- [17] N.C.M. Fuller, M.V. Malyshev, V.M. Donnelly and I.P. Herman, *Plasma Sources Sci. Technol.* **9** (2000) 116

treba pogledati Gudmundsson 2004 *J. Phys. D: Appl. Phys.* **37** 2073. doi:10.1088/0022-3727/37/15/005.

ICOPS 2015

Abstract Book

The 42nd IEEE
International
Conference
On Plasma Science
24-28 May 2015
Belek, Antalya, Turkey

PRODUCTION OF ACTIVE OXYGEN SPECIES IN LOW PRESSURE CCP USED FOR STERILIZATION OF COMMERCIAL SEEDS*

Kosta Spasić, Nikola Škoro, Nevena Puač, Gordana Malović,
Zoran Lj. Petrović
*Institute of Physics, University of Belgrade, Pregrevica 118
11080 Belgrade, Serbia*

Long-term storage of commercially important seeds, for instance maize and wheat, in such way to keep unwanted microorganism infections from appearing and spreading is very important, but challenging task. Fortunately, even when an infection starts to spread, plasma treatment can be used to sterilize seeds in a cheap and reliable manner instead of traditional, ecologically unfriendly, chemical treatments [1].

We have developed a large scale asymmetric CCP plasma reactor for industrial scale treatment of sensitive samples. Powered electrode is axially placed aluminum rod, while chamber wall serves as a grounded electrode. Plasma is created by 13.56 MHz power generator with matching network.

A detailed diagnostics of this plasma source was performed in order to ensure the best possible treatment, energy efficiency and ecological acceptability of the process and to acquire full knowledge of relevant plasma chemistry taking place. Here, we present results of mass spectrometry and actinometry in a plasma produced in the mixture of 99% O₂ and 1% Ar.

Both diagnostics were scanned side-on, perpendicularly to the powered electrode. Mass spectrometer collected samples 30 cm from the powered electrode. For actinometry, emission intensities were integrated along the line of sight. Measurements were performed at pressures of 300, 450 and 600 mTorr while applied RF power was varied between 100 and 700 W.

Most abundant neutral species were O₂, O, Ar and N₂ at all pressures investigated. Presence of N₂ can be explained by the fact that only a mechanical pump was used. As expected, O atom yield increases with power and pressure due to higher dissociation of O₂. From the actinometry measurements we confirmed this increase and calculated the dissociation degree to be below 5% for all conditions. The most abundant positive ions are O⁺ and O₂⁺ while the most abundant negative ion is O⁻.

I. I. Filatova, V. Azharonok, V. Lushkevich, A. Zhukovsky, G. Gadzhieva, K. Spasić, S. Živković, N. Puač, S. Lazović, G. Malović and Z. Lj. Petrović, "Plasma seeds treatment as a promising technique for seed germination improvement", 31st ICPIG, July, 2013

* Work supported by MESTD, III41011 & ON171037

Optical Emission Diagnostics of N₂ plasma used for textile pretreatment

Nevena Puač^{1(*)}, Kosta Spasić¹, Nikola Škoro¹, Marija Gorjanc², Gordana Malović¹ and Zoran Lj Petrović¹

¹ Institute of Physics, University of Belgrade, Pregrevica 118, Belgrade, Serbia

² Faculty of Natural Sciences and Engineering, University of Ljubljana, Aškerčeva cesta 12, Ljubljana, Slovenia
 (*) nevena@ipb.ac.rs

We have used plan parallel plasma reactor with adjustable electrode distance for treatment of cotton samples. In order to better understand interactions between plasma and the sample we have conducted real-time optical emission spectroscopy in nitrogen plasma while the treatments were carried out. The behavior of the strongest line in N₂ 2nd positive system (337.13 nm) was investigated for the two different electrode distances for the cases with and without the sample inside the chamber. The effect of plasma on the treated sample was determined through adsorption of Functional carbonaceous material (FCM) onto the cotton and resulting coloring yield.

Even though successful methods for textile pretreatment already exist, they are chemically based which means that they are not environmentally friendly. Low-pressure plasma treatment, as a pollutant-free method, is much more ecologically accepted and beneficiary effects on textiles have already been shown. [1-5]. However, reliable and simple real-time monitoring of the treatment is necessary in this case.

In our investigation we used plasma reactor with plan parallel electrodes, 11 cm in diameter and the interelectrode distance that can be continuously changed between 4 and 7 cm. Upper powered electrode is shower-head type serving as gas inlet while the lower grounded electrode serves as sample holder. Chamber windows allow direct end-on and side-on view to the whole discharge volume between electrodes. For optical emission measurements a focusing lens in front of the entrance slit of spectrometer was used. The light emission was collected from the region just above the lower electrode. This was accomplished by masking part of the window and limiting the observation angle to that region. All treatments and measurements were done in nitrogen plasma at pressure of 100 mTorr with RF power ranging from 25 to 200 W.

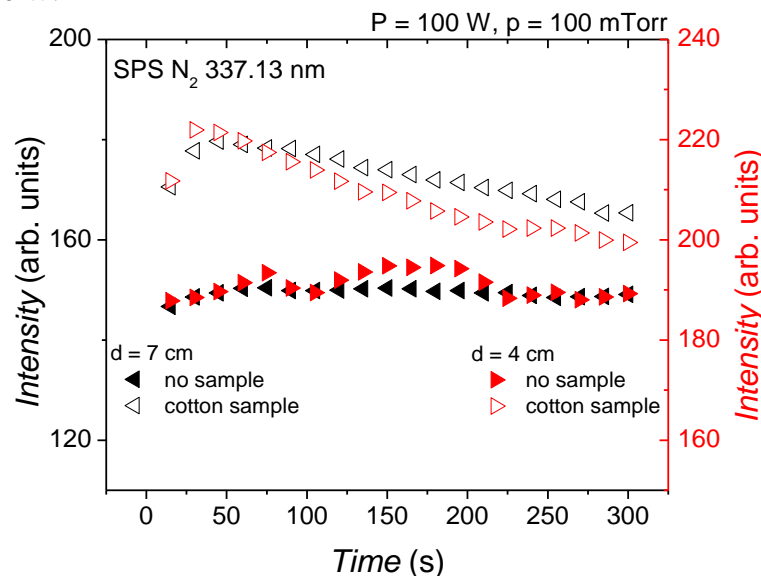

Fig. 1: Time evolution of intensities of 337.13 nm N₂ 2nd positive system line at 100 mTorr and 100 W power at d = 4 cm (right side axis) and d = 7 cm (left side axis) without and with a sample in the chamber.

In Fig. 1 we present time-resolved measurements of the emission line intensity for two electrode distances and for two cases: without a sample (full symbols) and with a cotton sample (open symbols).

Presented data is for the strongest line in N_2 2nd positive system - 337.13 nm line. Recordings of the spectra were made in 15 s-acquisition series which allowed us to take several measurements during duration of treatment (5 mins) in order to follow emission evolution.

Time evolution of the selected line was followed at electrode distances $d = 4$ cm (right side axis) and $d=7$ cm (left side axis). The overall line intensity is higher at interelectrode distance of 4 cm than when the electrodes were at the distance of 7 cm. For both electrode gaps without a sample inside the chamber (full symbols) intensities were almost constant in time, with small irregular oscillations around one value.

However, when a cotton sample is present in the chamber, the line intensity peaks approximately 30 s after the beginning of treatment and then gradually decrease over time until the end of the treatment time (open symbols). In case of $d=4$ cm this phenomena is more pronounced which can be explained by the stronger plasma that leads to more intensive plasma/sample surface interactions. Also, the intensity of the 337.13 nm line drops faster after the initial increase than in the case of electrode distance of 7 cm. At the end of the treatment, the intensity of the measured line is approaching the case without a sample present for both electrode distances. This was checked in another set of experiments and after longer treatment time the intensity reaches the value obtained without sample.

In order to link these results with the effect that plasma has on the cotton sample we have performed experiments where the adsorption of FCM onto cotton was investigated. These results are presented in Figure 2. We can see that color yield is higher in the case of larger distance from electrode ($d=7$ cm) which means that the plasma/sample interaction is more effective in case of larger electrode distance i.e. at milder plasma conditions.

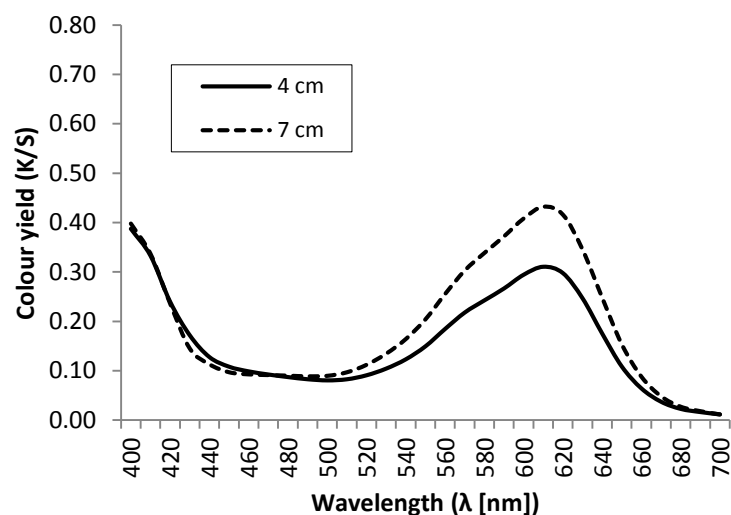

Fig. 2: K/S values of cotton samples treated at two different electrode distances: $d = 4$ cm and $d = 7$ cm; $P = 100$ W, treatment time 5 mins, $p = 100$ mTorr N_2 .

Acknowledgment

This work is supported by Ministry of Education, Science and Technological development of Serbia under project numbers ON171037 and III41011.

References

- [1] M Gorjanc V Bukošek, M Gorenšek, A Vesel, *Textile research journal* 80.6 (2010): 557-567.
- [2] D Mihailovic, Z Saponjic, R Molina, N Puac, P Jovancic, J Nedeljkovic, M Radetic, *ACS applied materials & interfaces*. (2010), 2 (6):1700-6.
- [3] Gorenšek M, M Gorjanc, V Bukošek, J Kovač, Z Petrović, N Puač *Textile research journal* 80.16 (2010): 1633-1642.
- [4] Hartwig H, *Pure and Applied Chemistry* 74.3 (2002): 423-427.
- [5] Z Cai, Y Qiu, C Zhang, Y J Hwang and M McCord *Textile Research Journal* 73.8 (2003): 670-674.

QUICK FIELD: [Author](#) [First Author](#) [Abstract](#) [Year](#) [Fulltext](#) 

Optical emission spectroscopy of OH lines in N₂ and Ar plasma during the treatments of cotton fabric

[Show affiliations](#)

[Skoro, Nikola](#) ; [Puac, Nevena](#) ; [Spasic, Kosta](#) ; [Malovic, Gordana](#) ; [Gorjanc, Marija](#) ; [Petrovic, Zoran Lj](#)

Low pressure non-equilibrium plasmas are proven to be irreplaceable tool in material processing. Among other fields their applications in treatments of textiles are still diversifying, but the main role of plasma is activation of the surface of treated sample. After, or during, the treatments these surfaces can be covered with different materials or species (such as microcapsules) that enhance properties of the fabric. In order to investigate mechanisms how active species from plasma interact with the cotton surface, we studied both plasma and surface properties. Bleached cotton samples were treated in low-pressure nitrogen and argon plasma in a chamber with parallel-plate electrodes. The effect of the plasma treatment on the cotton samples was investigated with the colorimetric measurements on dyes absorption by a spectrophotometer. Optical emission spectroscopy was performed by using spectrometer with a sensitive CCD camera. We have recorded the evolution of the maximum of the intensity of OH and N₂ second positive band lines. Measurement were done with and without samples in the chamber and comparison between the lines intensity was made. The parameters for optimal plasma treatment conditions were determined.

Research supported by the MESTD, projects III41011 and ON171037.

Publication: APS Gaseous Electronics Conference 2016, abstract id. MW6.058

Pub Date: September 2016

Bibcode: [2016APS..GECMW6058S](#)



GASEOUS ELECTRONICS MEETING

PROGRAMME

Sunday 14th February to Wednesday 17th February 2016.
Deakin University, Geelong, Victoria, Australia.



Diagnostics of atmospheric pressure plasma jets and plasma needle and their application in biology and medicine

Z.Lj. Petrović^{1,2}, N. Puač², G. Malović², N. Selaković², K. Spasić², D. Maletić², S. Živković³

¹ Serbian Academy of Sciences and Arts, Belgrade, Serbia

² Institute of Physics, University of Belgrade, Belgrade, Serbia

³ Institute for Biological Research “Siniša Stanković”, University of Belgrade, Belgrade, Serbia

Email contact: zoran@ipb.ac.rs

In attempts to facilitate creation of non-equilibrium plasmas at atmospheric pressure usually one of several possible tricks is employed that allows us to reduce the growth of ionization and prevent the development of thermal (equilibrium) plasma. Also, a standard feature of atmospheric pressure plasmas is to have a relatively small size bordering on micro discharges. Therefore many diagnostics techniques had to be developed or adapted to suit the properties of these plasmas. We shall discuss ICCD recorded spatial/temporal emission profiles, mass spectrometry, Volt-Ampere characteristics and power measurement. The plasma sources that we cover here are primarily atmospheric pressure plasma jet operating at 80 kHz and plasma needle operating at 13.56 MHz. We discuss some features of such discharges, development of ionization fronts and detected radicals and ions [1].

If one wants to understand the effect of plasma on living tissues/cells one needs to follow the trail of active particles, mostly radicals (Reactive Oxygen and Nitrogen species -RONS) and we have been able to connect the radicals from the plasma through the liquid (water) to the cell itself. Some long and short term responses to the plasma treatment have been observed and explained through the kinetics of enzymes.

In practical terms plasmas are interesting for sterilization of bacteria and viruses (including the resistant species), activation of growth, stem cell differentiation and many more. Apart from effects in medicine we shall show also effects on plants, seeds and calli [2], effects on multicellular living organisms and in addition we discuss the plasma toxicity.

[1] N. Puač, D. Maletić, S. Lazović, G. Malović, A. Đorđević, Z. Lj. Petrović, Appl.Phys.Lett. 2012, 024103.

[2] N. Puač, S. et al. Appl. Phys. Lett. 2014, 214106.

ICPIG 2017

XXXIII INTERNATIONAL CONFERENCE
ON PHENOMENA IN IONIZED GASES

CONFERENCE PROCEEDINGS

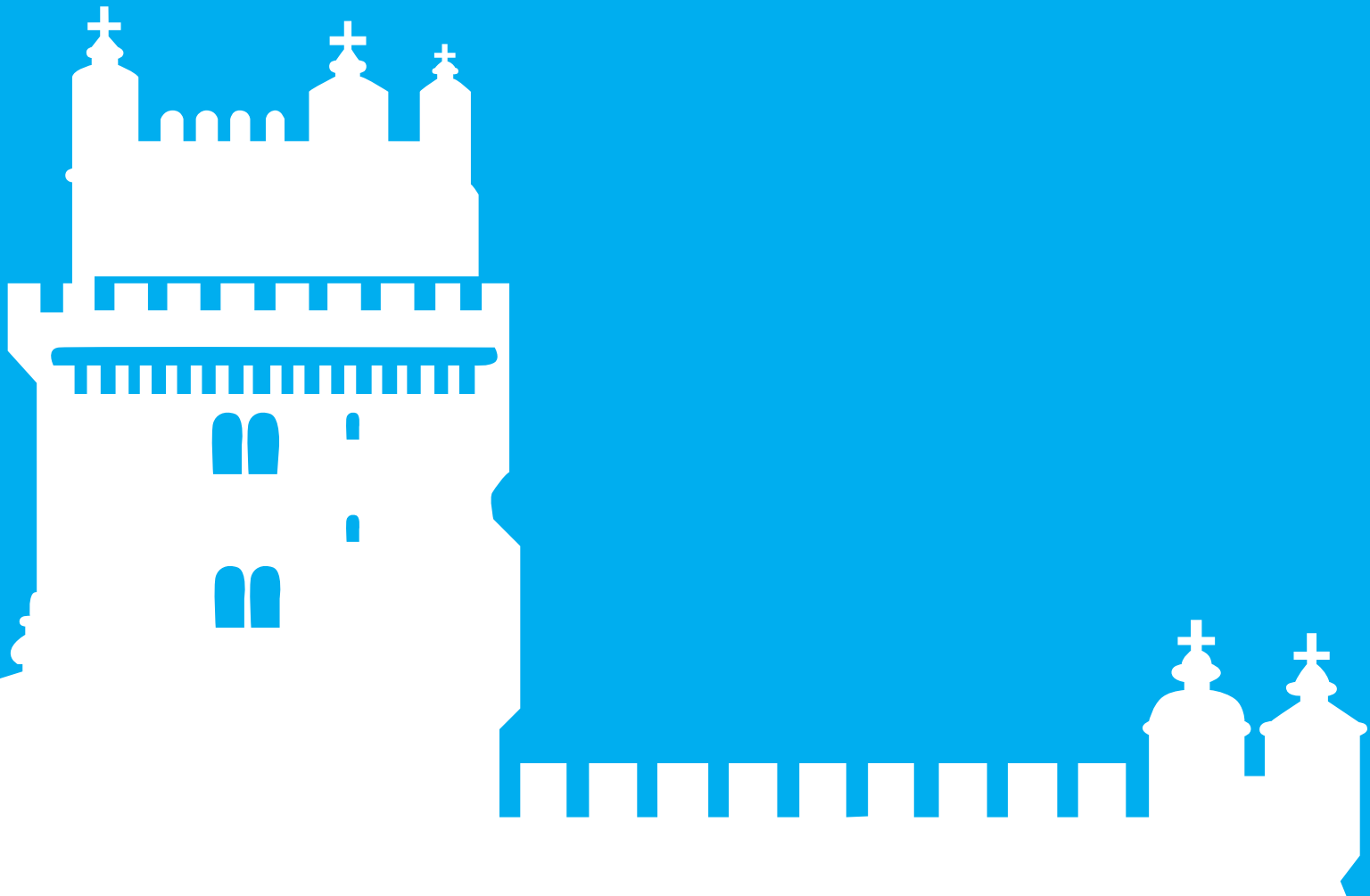

Proceedings of the
XXXIII
INTERNATIONAL
CONFERENCE ON
PHENOMENA IN IONIZED
GASES

Estoril, Portugal. 9-14 July 2017

Editors:

Luís Lemos Alves
Antonio Tejero-del-Caz

Published by:

Instituto de Plasmas e Fusão Nuclear

Instituto Superior Técnico

Universidade de Lisboa

<http://icpig2017.tecnico.ulisboa.pt>

Credits:

Editors: Luís Lemos Alves

Antonio Tejero-del-Caz

Cover design: Irene Lemos Alves

The XXXIII ICPIG (International Conference on Phenomena in Ionized Gases) has been organized by Instituto de Plasmas e Fusão Nuclear from Instituto Superior Técnico, Universidade de Lisboa, Universidade do Porto and Universidade do Minho.

The XXXIII ICPIG was organized in accordance with IUPAP principles, regarding the free circulation of scientists for international collaborations and discussions, as stated in the declaration of the International Council of Science, adopted at the 26th General Assembly in 2008 and endorsed by the 27th General Assembly in 2011. In particular, no *bona fide* scientist is excluded from participation on grounds of origin, nationality or political considerations unrelated to science.

Permission to make digital or hard copies of portions of this work for personal or classroom use is granted without fee provided that copies are not made or distributed for profit or commercial advantage. Abstracting is permitted with credit to the source.

Activity of catalase enzyme in *P. tomentosa* seeds after direct plasma treatments and treatments with plasma activated water

N. Puač¹, N. Škoro¹, K. Spasić¹, S. Živković², M. Milutinović², V. Šašić², G. Malović¹ and Z.Lj. Petrović^{1,3}

¹Institute of Physics, University of Belgrade, Pregrevica 118, 11080 Belgrade, Serbia

²Institute for Biological research "Siniša Stanković", University of Belgrade, B. despota Stefana 142, 11000 Belgrade, Serbia

³Serbian Academy of Sciences and Arts, Knez Mihailova 35, 11000 Belgrade, Serbia

In this abstract we report on influence of direct and indirect plasma treatments on catalase enzyme activity in *Paulownia tomentosa* seeds. The direct treatment of the seeds was performed in low-pressure RF plasma system for different treatment times. After treatments these seeds were imbibed with distilled water. The other set of *P. tomentosa* seeds was imbibed with plasma activated water (PAW). PAW was produced by using atmospheric pressure plasma source in treatments with different durations. Seeds from both sets were exposed to the same conditions and after 5 days activity of catalase enzyme was measured. In comparison to the control sample, differences in the activity was observed both regarding direct and PAW treated seeds and regarding duration of treatments.

1. Introduction

Non-equilibrium low and atmospheric pressure plasmas can be efficiently used in stimulation of seed growth, increase of germination percentage and decontamination, breaking of dormancy or increase in the length of seed sprout. We have developed several low pressure and atmospheric pressure plasma systems for treatment of seeds and plant cells [1-3]. Here we will present the results obtained in treatments of *Paulownia tomentosa* seeds by non-equilibrium plasma that operates at low and atmospheric pressures. We have determined the germination percentage and activity of catalase enzyme for all treated samples and compared it to the control samples.

2. Results and discussion

Low pressure plasma treatments of seeds were performed in the cylindrically shaped RF plasma system that operates at 13.56 MHz reactor. The seeds were then imbibed with distilled water. Unlike low pressure plasma treatments where seeds were in direct contact with plasma, in case of atmospheric pressure plasma treatments we have treated distilled water (PAW) which was then used for imbibition of seeds. After the imbibition process seeds were exposed to red light for 5 min. In Figure 1 we show activity of catalase enzyme 5 days after imbibition of water. The catalase activity for the treated samples is increased comparing to the untreated sample. This is in accordance with the observed increase in germination percentages obtained for this samples.

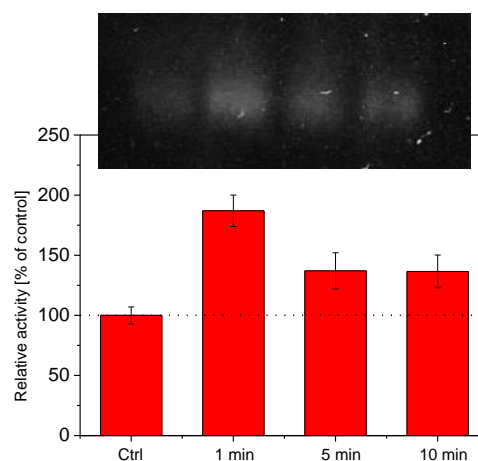

Figure 1. The activity of the catalase enzyme obtained by using native page. Data was obtained five days after the imbibition of water (distilled).

This work was supported by the MESTD of Serbia projects III41011 and ON171037.

3. References

- [1] N. Puač, Z.Lj. Petrović, S. Živković, Z. Giba, D. Grubišić and A.R. Đorđević, *Plasma Processes and Polymers*, Wiley-VCH Verlag GmbH & Co. (2005).
- [2] N. Puač, Z.Lj. Petrović, G. Malović, A. Đorđević, S. Živković, Z. Giba and D. Grubišić, *J. Phys. D:Appl. Phys.* **39** (2006) 3514-3519.
- [3] N. Puač, S. Živković, N. Selaković, M. Milutinović, J. Boljević, G. Malović and Z.Lj. Petrović, *Appl. Phys. Lett.* **104**(21) (2014) 214106.

Effects of power transfer efficiency and grounded electrode surface on creation of O and O₂ excited species in low pressure plasmas

K. Spasić¹, N. Puač¹, G. Malović¹ and Z. L. Petrović^{1,2}

¹*Institute of Physics, University of Belgrade, Pregrevica 118, 11000 Belgrade, Serbia*

²*Serbian Academy of Sciences and Arts, Knez Mihailova 35, 11000 Belgrade, Serbia*

Abstract: We have constructed large volume discharge chamber for streamer free treatments of sensitive samples such as seeds or textiles. Mild plasmas are achieved due to large asymmetry between areas of powered and grounded electrode. Excited species of O and O₂, which participate in the interactions with living cells, were measured by mass spectrometry. Effects of size of grounded electrode and power transfer efficiency on creation of those species was also investigated.

Keywords: plasma chemistry, mass spectrometry, low pressure, power efficiency

1. Introduction

Interest for research of low pressure plasmas stems from their wide range of applications. They are extensively used in manufacturing of electronics, car and plane parts and medical equipment [1-5]. In textile industries they can be used for ecologically acceptable colouring preparation, shrinkage reduction and deposition of bactericidal material or various microcapsules [6-10]. Relatively new, but quickly expanding field of application is plasma agriculture where they are used to increase seed germination and sprouts growth speed, remove various pathogens or influence enzyme activity [11-14].

Low pressure plasmas are known to be easily controllable and relatively cheap to implement. Due to high number of active species in any plasma and numerous processes in which they can take part, complicated plasma chemistry and treatment effects are very sensitive to even subtle changes in either system geometry or discharge parameters. In this research we will test how does size of grounded electrode influence creation of excited species of oxygen atom and molecule which are important in treatment of biological samples. In addition, relation between abundance of excited species and power transfer efficiency will be explored.

2. Experimental set-up

In order to create plasma reactor that would be suitable for treatment of sensitive samples on an industrial scale, we have crated large volume asymmetrical discharge chamber. Cylindrical geometry was selected so that streamer free discharges can be achieved. Chamber is made out of stainless steel. It is 2.5 m long and 1.17 m wide. Outer wall also serves as grounded electrode while powered electrode is axially placed aluminum rod which is 1.5 m long and 3 cm in diameter. During treatments samples are usually placed on sample holding platform which is 46 cm bellow powered electrode and it is also grounded.

Additional, smaller, grounded electrode is created so that we could test how does different ratio of surfaces of powered to grounded electrode affect plasma composition and power efficiency. It is made of aluminium and it has diameter of 63 cm. It is in electrical contact with both chamber wall and sample holding platform so that ground potential can be maintained. When additional electrode is

placed, plasma is ignited only in the volume between powered and smaller grounded electrode. It is schematically presented in Figure 1.

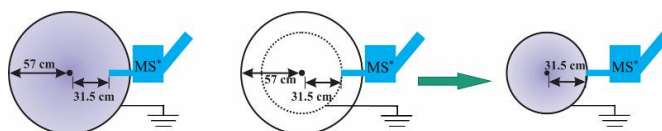

Fig. 1. Placement of additional smaller grounded electrode. MS is mass spectrometer

Pressure inside chamber was controlled by controlling flow of working gasses. They were introduced into the chamber through the system (Figure 2) which allows mixing of up to four different gasses. For this work we have used mixture 99% of oxygen and 1% of argon. Pressures were varied between 300 and 600 mTorr. Vacuum was achieved and maintained by Pfeiffer vacuum Duo 65 mechanical pump.

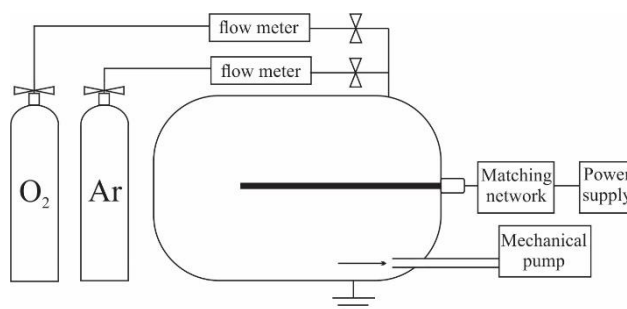

Fig. 2. Electrical and vacuum system

Discharge power was increased up to 700 W at 13.56 MHz and it was provided by Dressler Cesar 1310 power supply. This power supply has maximum output of 1000 W and it is equipped with matching network so we could keep reflected power under 2% of forwarded one.

Mass and energy analysis was performed by HIDEN EQP spectrometer which is placed side-on (see Fig.1.). Distance between powered electrode and sampling orifice of mass energy analyser cannot be changed and it stands at 31.5 cm. In case when smaller grounded electrode was in position, orifice was at the level of grounded electrode as

shown in Fig. 1. When measurements were performed without it (original large chamber wall was grounded electrode), orifice is positioned inside the plasma and 20 cm away from grounded chamber wall.

Since mass spectrometer can manipulate only with ions, ionisation is required for the measurement of neutral species. It is performed inside the internal ionization unit by electrons. The energy of electrons can be adjusted with a step of 0.1 eV with minimum energy of 4 eV. The detection of ionized species can then be performed in two modes. The first mode can give the complete mass spectra ($m/Z=1-300$ amu) while the energy of ionizing electrons is fixed at specific value. The second mode, which was used in this research, is such that for the fixed m/Z ratio the mass spectrometer is scanning over the specified range of energies of ionizing electrons. In this case, in order to improve low signal to noise ratio at low energies of ionizing electrons, measurements were performed 12 times for each condition.

Assessments of power transfer efficiency were performed by using derivative probes. One example of their construction is shown in Fig. 3. They should be placed as close to powered electrode as possible in order to minimise any power loss between measuring point and plasma itself. In our set-up we were able to position them directly on part of powered electrode which is outside of chamber. They are constructed as a couple of probes. Current probe which is shaped as a coil and voltage probe in a shape of letter T. Power value is obtained by multiplying calibrated current and voltage signals.

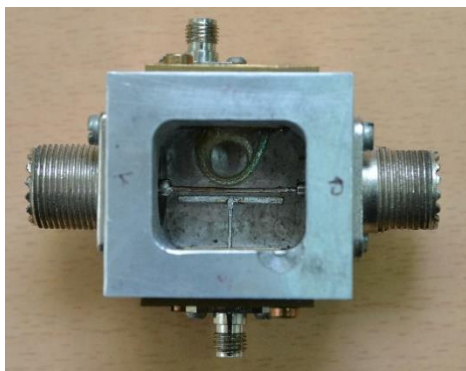

Fig. 3. Derivative probes

3. Results and discussion

Interaction between plasma and plasma treated surface is a complicated set of processes that are defined not only by presence of ions and electrons but of various excited species as well. To detect those species special procedure has to be applied. For that purpose we have applied mass-energy analysis.

Processes of ionization that are required for detection of neutral species by mass spectrometer have certain energy thresholds. Two important reactions of our interest are presented in Table 1. When discharge is turned off, ionizing electrons with energies below these thresholds are

not capable of ionization of either molecules or atoms so no detection is taking place. On the other hand when plasma is turned on certain amount of excited species is created. When they enter internal ionization unit they can be ionized with electrons whose energy is well below 13.6 eV for oxygen atoms ($m/Z=16$) or 12.6 for oxygen molecules ($m/Z=32$) [15, 16, 17].

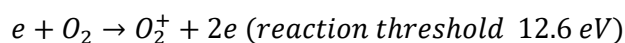
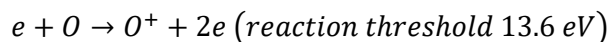

Table 1. Reaction thresholds for creating oxygen ions

In order to count excited particles of certain species it is necessary to fix m/Z ratio to desired value (16 or 32) and perform scan over different energies of ionizing electrons. By integrating that curve up to ionization threshold energy we can get number of all excited particles at selected m/Z that have entered mass-energy analyser.

3.1. Grounded electrode – smaller area

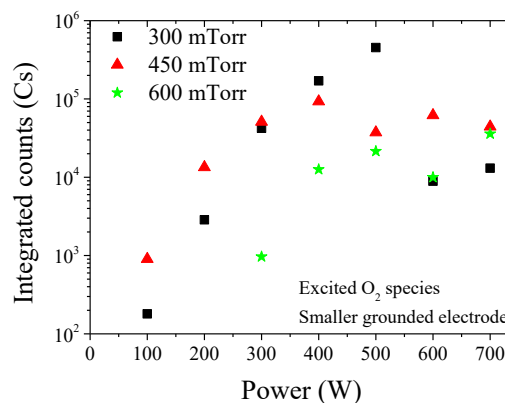

Fig. 4. Excited species of oxygen molecule when smaller grounded electrode was used

Measurements of excited species of oxygen molecule at three different pressures with smaller grounded electrode are presented in Fig. 4. At all three pressures we have certain maximum values after which we have drop in number of excited species with further increase of power. To clarify this situation additional measurements of power transfer efficiency were performed at same discharge conditions and they are presented at Fig. 5.

The most visible feature in Fig. 5 is spike in power transfer efficiency between 400 W and 500 W at pressure of 450 mTorr. It is interesting to note that at the same power we have drop in number of O_2 excited species. On the other hand at lowest pressure of 300 mTorr there is almost constant efficiency up to 500 W which is followed by decline. At that pressure there is an increase in number of excited species up to 500 W with sharp drop in their numbers at higher applied powers. At the highest pressure

of 600 mTorr both power transfer efficiency and number of excited O_2 particles are getting higher at higher powers. We have tried to detect excited oxygen atoms in presence of smaller grounded electrode, but for these conditions their presence is negligible probably due to the recombination on the wall.

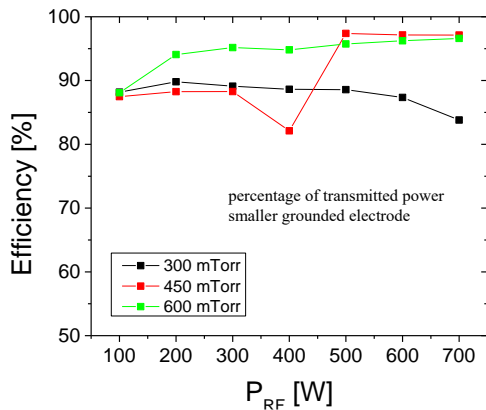

Fig. 5. Power transfer efficiency when smaller grounded electrode was used

3.2. Grounded electrode – larger area

In this configuration the orifice of the mass spectrometer is positioned inside the plasma volume and away of the grounded electrode i.e. chamber wall. Therefore, the influence of the recombination of O atoms due to the presence of the wall is negligible. The measured excited O atoms are presented in Fig. 6. We can see that with the power increase number of excited O atoms reaches the maximum value and then decreases with the position of the minimum depending on the working pressure.

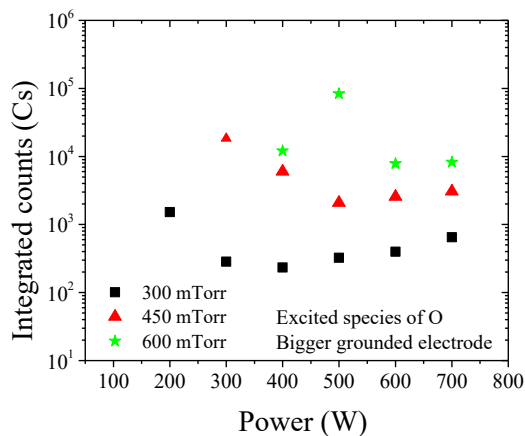

Fig. 6. Excited species of oxygen atom when bigger grounded electrode was used

On the other hand, number of excited oxygen molecules steadily decreases with the power increase (see Fig.7.). As in case of the smaller electrode there can be found the threshold power at which we can detect excited oxygen molecules species. These values of threshold power increase with the increase of the pressure. For the highest

powers the number of excited oxygen molecules reaches a plateau for all three applied pressures.

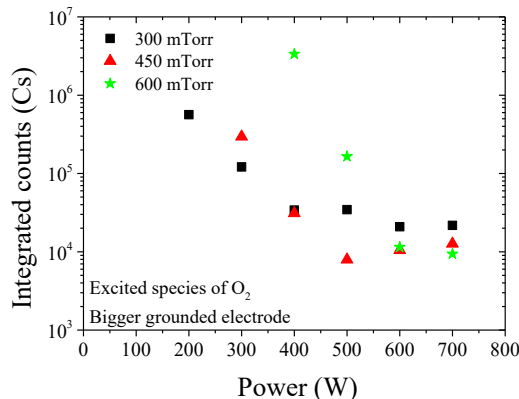

Fig. 7. Excited species of oxygen molecule when bigger grounded electrode was used

In case of large area grounded electrode power transfer efficiency is rising with applied power at all three pressures up to a pressure dependent plateau values after which it goes through a mild decline (see Fig. 8.). Only at the lowest pressure there is a sharper drop of about 10% after 500 W. Higher efficiency is measured at lower pressures. Both atom and molecule species have minimum power below which no detection is possible. At two out of three pressures, maximum number of excited atom species is measured at that minimum power while for molecule species maximal numbers are always detected at minimal powers. Contrary to power transfer efficiency higher number of excited particles are detected at higher pressures. Also in contrast with efficiency, number of excited molecule species are dropping about one order of magnitude with increase in applied RF power before they reach plateau values. Numbers of excited atom species are decreasing to their minimal value which coincide with power efficiency plateau values after which they slowly grow with further increase in power.

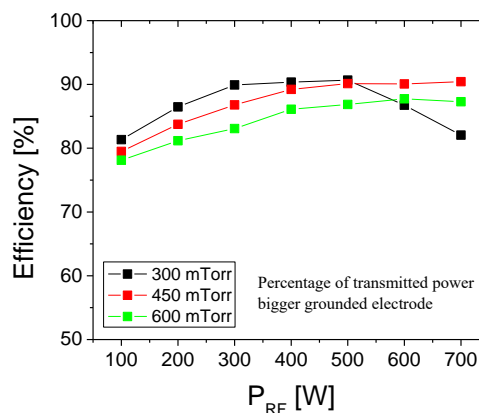

Fig. 8. Power transfer efficiency when bigger grounded electrode was used

4. Conclusion

We have tested influence of the area of the grounded electrode on the power transfer efficiency and creation of excited species of oxygen atoms and molecules in the discharge. It is shown that in case of larger electrode increase in efficiency either due to pressure or applied power leads to drop in number of O and O₂ excited species. On the other hand in case of smaller grounded electrode situation is more complicated due to fact that orifice of the mass spectrometer is at the level of the grounded electrode (i.e. chamber wall). In this case we could not detect any excited oxygen atoms due to the recombination process. Relation between creation of excited species and power efficiency is different at different pressures.

5. References

- [1] T. Makabe, Z.L. Petrovic, Plasma electronics: applications in microelectronic device fabrication, CRC Press, (2014).
- [2] D.B. Graves, Plasma processing. IEEE transactions on Plasma Science, **1**, 31-42 (1994).
- [3] J.L. Shohet, Plasma-aided manufacturing, IEEE Transactions on plasma Science, **5**, 725-33 (1991).
- [4] F. Arefi-Khonsari, J. Kurdi, M. Tatoulian, J Amouroux, Surface and coatings Technology, **142**, 437-48 (2001).
- [5] C. Oehr, Nuclear Instruments and Methods in Physics Research Section B: Beam Interactions with Materials and Atoms, **1**, 208, 40-7 (2003).
- [6] P. Erra, R. Molina, D. Jovic, M.R. Julia, A. Cuesta, J.M. Tascon, Textile Research Journal, **69**, 11, 811-5 (1999).
- [7] M. Radetic, P. Jovancic, N. Puac, Z.L. Petrovic, Journal of physics: conference series, **71**, 1, 012017 (2007).
- [8] M.M. Hossain, A.S. Herrmann, D. Hegemann, Plasma Processes and Polymers, **4**, 2, 135-44 (2007).
- [9] M. Radetić, V. Ilić, V. Vodnik, S. Dimitrijević, P. Jovančić, Z. Šaponjić, J.M. Nedeljković, Polymers for advanced technologies, **19**, 12, 1816-21 (2008).
- [10] M. Gorjanc, M. Mozetič, G. Primc, A. Vesel, K. Spasić, N. Puač, Z. L. Petrović, M. Kert, Applied Surface Science, **419**, 224-34 (2017).
- [11] J. C. Volin, F.S. Denes, R.A. Young, S.M. Park, Crop Science, **40**, 6, 1706-18 (2000).
- [12] M. Selcuk, L. Oksuz, P. Basaran, Bioresource technology, **99**, 11, 5104-9 (2008).
- [13] B. Sera, P. Spatenka, M. Sery, N. Vrchotová, I. Hruskova, IEEE Transactions on Plasma Science, **38**, 10, 2963-8 (2010).
- [14] N. Puač, N. Škoro, K. Spasić, S. Živković, M. Milutinović, G. Malović, Z.L. Petrović, Plasma Processes and Polymers, **15**, 2, 1700082 (2018).
- [15] Y. Itikawa, A. Ichimura, Journal of Physical and Chemical Reference Data, **19**, 3, 637-51 (1990).
- [16] Y. Itikawa, Journal of Physical and Chemical Reference Data, **38**, 1, 1-20 (2009).
- [17] NIST database



Characterization of a large scale RF CCP reactor using Langmuir and derivative probes

Saša Lazović, Nevena Puač, Kosta Spasić, Gordana Malović and Zoran Lj. Petrović

Institute of Physics, Pregrevica 118, 11080 Belgrade, Serbia

University of Belgrade, Studentski trg 1, 11080 Belgrade, Serbia

Characterization of a large scale RF CCP reactor using Langmuir and derivative probes

Saša Lazović, Nevena Puač, Kosta Spasić, Gordana Malović and Zoran Lj. Petrović

Institute of Physics, Pregrevica 118, 11080 Belgrade, Serbia

University of Belgrade, Studentski trg 1, 11080 Belgrade, Serbia

Abstract: A large scale cylindrical CCP reactor was developed as a prototype of an industrial device, aiming to show that continuous plasma treatment of textile rolls at low pressures is possible. Discharge is large in volume ($\sim 3 \text{ m}^3$), homogeneous and free from transitions to streamers. Treatment effects are strongly dependant on the distance between the central electrode and the textile sample. Powered electrode is made of aluminum (1.5 m long) while chamber walls are the grounded electrode. In this type of asymmetric discharge, concentrations of ions coming to the surface are decreasing when samples are placed further away from the powered electrode. Langmuir probe (Hiden ESPION) which was placed side-on was used to perform measurements of the spatial profiles of ions and electrons. Current and voltage derivative probes are used to obtain U-I characteristics as well as power delivered to the plasma, providing useful information on plasma operation mode. Measurements are performed in Argon at 400, 600, 800 and 1000 mTorr, for several distances from the powered electrode and for different powers delivered to the plasma.

Keywords: large scale asymmetric cylindrical RF CCP reactor, Langmuir probe, current and voltage derivative probes

1. Introduction

Radiofrequency discharges are necessary for treatment of isolators and semiconductors [1]. Different kinds of conductive and non-conductive materials like microelectronics devices [2-4], biological samples [5] and textiles [6] can be treated using capacitively coupled RF plasmas. In our laboratory a large scale CCP RF reactor was developed in order to cheaply and uniformly treat textile rolls without damaging the surface of the fibers. Homogeneous and stable plasma, without transition to streamers, capable of long term stable operation (i.e. treatments) was achieved. Detailed electrical characterization of the plasma reactor is

however required because it can provide information on the relations between external discharge properties (current and voltage waveforms, impedance) and plasma parameters (densities, energies, fluxes of charged particles).

Textile samples can be placed in the chamber on several distances from the powered electrode providing various intensities of treatment. Langmuir probe measurements are performed in argon, for different distances, powers and pressures of the working gas. Ion and electron concentrations are obtained at the places where textile sample would be placed. These measurements show complex spatial dependences of the concentrations and are important

for proper characterization of treating procedures. Current-voltage properties and power delivered to plasma can be measured using derivative probes.

2. Experimental setup

The discharge chamber is 2.5 m long and 1.17 m in diameter and made of stainless steel. Powered electrode is placed axially in the centre of the chamber and is 1.5 m long, 3 cm in diameter and made of aluminium. The chamber has a platform at the bottom where samples are placed. The distance between the platform and the powered electrode is adjustable by moving the platform. Distances for the Langmuir probe measurements were chosen within this range. Outer chamber wall is the grounded electrode. The rest of the electrical circuit consists of RF power generator Dressler Cesar 1010 in combination with Variomatch matching network. Derivative probes are placed into a stainless steel box opposite to each other. The box is placed as close as possible to the powered electrode. Low pressures are maintained using mechanical vacuum pump with a constant flow of gas air (see Fig.1).

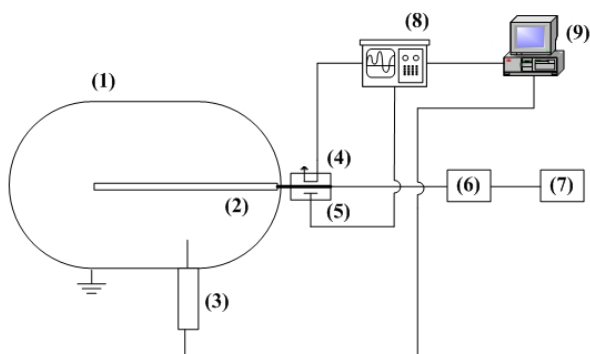

Figure 1. Experimental set-up: (1) Chamber, (2) Powered electrode, (3) ESPION system, (4) Current probe, (5) Voltage probe, (6) Variomatch, (7) Power supply, (8) Oscilloscope, (9) Computer

Instantaneous voltages and currents are monitored using derivative probes which were connected to the oscilloscope with cables of identical length. All waveforms are collected by the computer for further analysis.

Hidden Analytical ESPION advanced Langmuir probe system is placed side-on. The system has a

linear motion drive which enables probe positioning with the minimal spatial resolution of 0.1 mm. Measurements were made in the range of pressures from 400 mTorr to 1 Torr. We have used platinum probe tip, 5 mm long and 0.15 mm in diameter. Linear motion drive was used to position the probe at the distances 50.5 cm to 20.5 cm from the powered electrode. Measurements of U-I curves were made for all those positions of Langmuir probe.

At every position 50 measurements were made each being an average of 10 scans with pre-cleaning for each measurement. It was observed that even with pre-cleaning it is better to neglect the first few measurements because of the probe contamination until results become stable. After that, the U-I curves were smoothed and data was processed using Hiden ESPSoft.

3. Results and discussion

3.1. Derivative probes measurements

Waveforms acquired by current and voltage derivative probes are further processed using Fast Fourier Transform procedure. Signals are then calibrated in the frequency domain and converted back to time domain using Inverse Fast Fourier Transform showing the real signal shapes. Figure 2. shows current and voltage signals after numerical procedures (for Argon at different pressures 400, 600, 800 and 1000 mTorr). Power at RF generator was 200 W (forward minus reflected power).

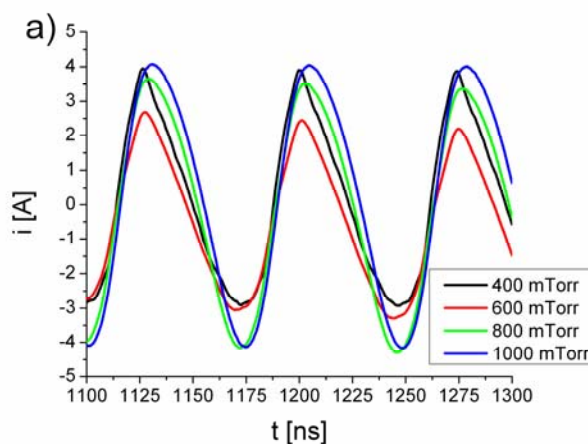

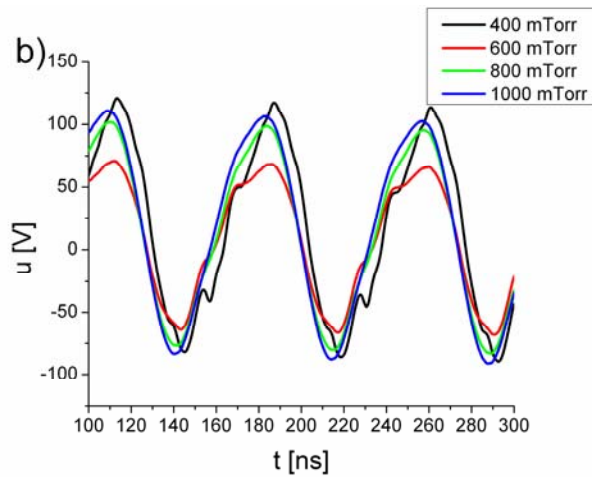

Figure 2. Derivative probe measurements of a) current and b) voltage waveforms for Argon discharge at 400, 600, 800 and 1000 mTorr. Power at the RF generator was 200 W.

Current signals are in the range of 5.5 A to 8.5 A peak to peak, and voltage is ranging from 130 V to 200 V peak to peak. At lower pressures (400 and 600 mTorr) current waveform has a saw tooth like shape and at higher pressures (800 and 1000 mTorr) it becomes more sinusoidal.

Voltage waveforms clearly indicate a presence of higher harmonics, especially at 400 and 600 mTorr. At higher pressures, waveforms become more sinusoidal. Generation of higher harmonics is due to geometrical asymmetry of the discharge chamber and due to the nonlinear nature of plasma impedance. In this configuration, having grounded electrode with a large area, and metal platform at the bottom for placing the samples, current paths can be very different in different parts of the chamber [7]. More detailed derivative probe and Langmuir probe measurements in different current branches would prove useful in an attempt to determine equivalent discharge chamber circuit, putting more light on the links between external and internal plasma parameters. Our main objective was to obtain homogeneous and stable plasma, find optimal treatment conditions and provide reproducible treatments based on electrical measurements. Power delivered to plasma, V-I characteristic and impedance of the discharge can also be calculated.

3.2. Langmuir probe measurements

Langmuir probe (Hiden ESPION) was placed perpendicular to the powered electrode. Measurements were performed for distances of 20.5 cm, 30.5 cm, 40.5 cm and 50.5 cm from the powered electrode in Argon at 400 mTorr and 1000 mTorr and powers at RF generator in range from 100 W to 300 W. At the lowest pressure (400 mTorr) both electron and ion concentrations are slightly lower than at 1000 mTorr (compare Figure 3. a) and b)). Electron concentrations are almost constant for all probe positions (see Figure 3.), while ion concentrations are decreasing by more than an order of magnitude as probe is placed closer to the grounded chamber wall (40.5 cm and 50.5 cm).

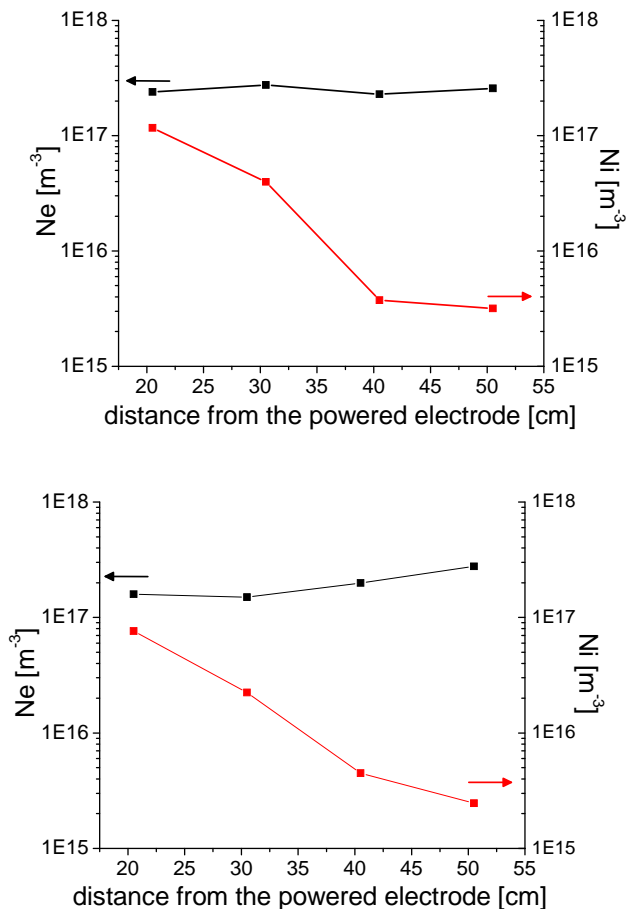

Figure 3. Electron and ion concentrations in Argon discharge at a) 400 mTorr and b) 1000 mTorr. Power at the RF generator was 300 W for both pressures.

Treatment effects of different kinds of materials strongly depend on ion concentrations and energies.

We can see that by placing the samples at different positions from the powered electrode we can control the concentrations of ions coming to the sample surface and therefore achieve different treating effects. Fine ion concentration adjustment in a range of almost two orders of magnitude (from $1e^{15}$ to $1e^{17}$ m^{-3}) can be achieved by precise positioning of the samples without changing power or pressure.

4. Conclusion

A large scale asymmetric RF CCP reactor at 13.56 MHz has been diagnosed by using derivative and Langmuir probes. Working gas was Argon and measurements by using derivative probes were committed for pressures of 400, 600, 800 and 1000 mTorr. Presented Langmuir probe results are obtained at 400 and 1000 mTorr for the power of 300 W given by the RF generator. Electron and ion concentrations were measured for several distances from the powered electrode (20.5, 30.5, 40.5 and 50.5 cm). It was found that shape of the current and voltage waveforms is changing with changing the gas pressure due to changing in plasma impedance and generation of higher harmonics. Current signals are in the range from 5.5 A to 8.5 A and voltage from 130 V to 200 V peak to peak.

For proper plasma treatment characterization and reproducibility, electron and ion concentrations were measured. Electron concentrations are found to be almost constant with changing the distance between the Langmuir probe and the powered electrode. Ion concentrations are changing in the range from $1e^{15}$ to $1e^{17}$ m^{-3} and are decreasing rapidly when moving away from the powered electrode. Changing of the distance between the sample and the powered electrode, may be used to control ion concentrations and treatment of the surfaces.

References

- [1] A. Bogaerts et al. / *Spectrochimica Acta Part B* 57 (2002) 609–658
- [2] M.A. Lieberman, A.J. Lichtenberg, *Principles of Plasma Discharge and Materials Processing*, (2005) (Wiley:Hoboken);

[3] T. Makabe, Z.Lj. Petrović, *Plasma Electronics*, (2006) (Taylor and Francis:New York);

[4] U. Cvelbar, K. (Ken) Ostrikov and M. Mozetic, *Nanotechnology* 19 (2008) 405605.

[5] N. Puač, Z.Lj. Petrović, S. Živković, Z. Giba, D. Grubišić and A.R. Đorđević, *Plasma Processes and Polymers*, (2005) 193, (Wiley)

[6] M. Radetić, P. Jovančić, N. Puač and Z.Lj. Petrović, *Workshop on Nonequilibrium Processes in Plasma Physics and Studies of the Environment, SPIG 2006, Journal of Physics: Conference Series* 71 (2007) 012017

[7] M. A. Sobolewski, *IEEE Transactions on Plasma Science* 23 (1995) 1006

Bulletin of the American Physical Society

[Bulletin Home](#)
[My Scheduler](#)
[Epitome](#)
[Author Index](#)
[Session Index](#)
[Invited Speakers](#)
[Chair Index](#)
[Word Search](#)
[Affiliation Search](#)
[Using Scheduler](#)

66th Annual Gaseous Electronics Conference

Volume 58, Number 8

Monday–Friday, September 30–October 4 2013; Princeton, New Jersey

Session CT1: Poster Session I (8:00-9:30AM)

8:00 AM, Tuesday, October 1, 2013

Room: Ballroom Foyer

Abstract ID: BAPS.2013.GEC.CT1.88

Abstract: CT1.00088 : Ion and atomic species produced in large scale oxygen plasma used for treatments sensitive materials*

[Preview Abstract](#)
[← Abstract →](#)

Authors:

Kosta Spasic
(Institute of Physics, University of Belgrade, Pregrevica 118, 11080 Belgrade, Serbia)

Nikola Skoro
(Institute of Physics, University of Belgrade, Pregrevica 118, 11080 Belgrade, Serbia)

Nevena Puac
(Institute of Physics, University of Belgrade, Pregrevica 118, 11080 Belgrade, Serbia)

Gordana Malovic
(Institute of Physics, University of Belgrade, Pregrevica 118, 11080 Belgrade, Serbia)

Zoran Lj. Petrovic
(Institute of Physics, University of Belgrade, Pregrevica 118, 11080 Belgrade, Serbia)

Asymmetric CCP plasma system operating at 13.56-MHz was successfully used for treatments of textile, seeds and polymers. Central electrode (aluminium rod) was powered electrode while the cylindrical wall of the chamber was grounded electrode. We have used mass spectrometry for detections of ions and neutrals in order to get better insight in plasma chemistry involved in surface reactions on treated samples. Besides of ions, one of the important species for surface modifications is atomic oxygen. Actinometry was used as an additional diagnostic tool to determine the extent of atomic oxygen produced in plasma. Measurements were made in several different mixtures of oxygen with addition of several percent of argon. The range of pressures investigated was 150 to 450-mTorr for powers from 100 to 500-W. Measured atomic oxygen density has a steady rise with power (10^{19} - 10^{20} -m⁻³). Apart from atomic oxygen species we have detected mass spectra of positive and negative ions. Most abundant ion was O₂⁺ while the amounts of O⁺ and O⁻ were smaller by the order of magnitude compared to O₂⁺.

*Supported by MESTD, RS, III41011 and ON 171037

To cite this abstract, use the following reference: <http://meetings.aps.org/link/BAPS.2013.GEC.CT1.88>

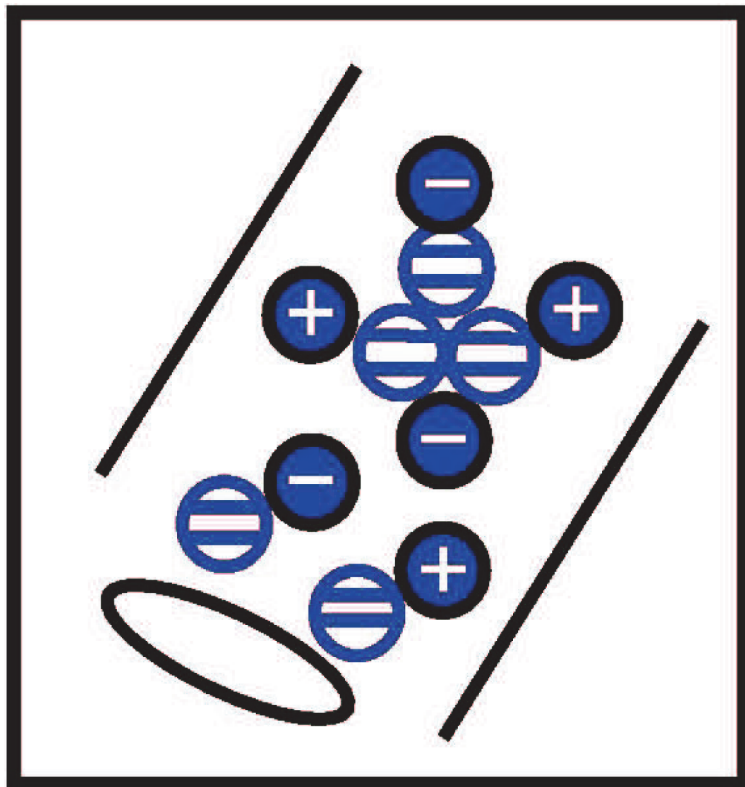

FLTPD XII
23-27 April 2017
Zlatibor, Serbia

ISBN 978-86-84539-19-1

Monitoring of the cotton fabric plasma treatments by using optical emission spectroscopy

N. Škoro^{1*}, N. Puač¹, K. Spasić¹, M. Gorjanc², G. Malović¹ and Z. Lj. Petrović¹

¹Institute of Physics, University of Belgrade, Pregrevica 118, Belgrade, Serbia

²Faculty of Natural Sciences and Engineering, University of Ljubljana, Aškerčeva cesta 12, Ljubljana, Slovenia

*Contact e-mail: nskoro@ipb.ac.rs

1. Introduction

One of the fields of application of non-equilibrium plasmas is in textile industry where plasma provides unique opportunity for treating the surfaces of textiles without affecting their bulk properties [1-2]. It was shown that pretreatments of cotton in low-pressure N₂ plasma cause activation of the surface improving adherence of covering species or materials (such as microcapsules) intended to enhance properties of the fabric. However, to have efficient and easily controllable treatments, one needs a reliable and simple real-time process monitoring. In this case, the monitoring parameter has to be associated both to plasma and surface processes.

2. Experimental setup

In our investigation we treated bleached cotton samples in low-pressure N₂ plasma in a chamber with parallel-plate electrodes. The distance between bottom grounded electrode (sample holder) and upper RF powered electrode was changed from 4 cm to 7 cm. Optical diagnostics of plasma volume above the sample was performed by using a spectrometer with an ICCD camera through a quartz window. The effect of the treatment on the sample surface was investigated in colorimetric measurements on dyes adsorption by using a reflectance spectrophotometer.

3. Results and conclusion

Colorimetric measurements of treated cotton samples provided values of colour yield (in K/S units) in wavelength interval 400-700 nm. Higher values of K/S indicate better adsorption of Functional carbonaceous material (FCM) onto the cotton samples. In all treated samples the results show that maximum of FCM adsorption is around 600 nm. Measured colour yield of cotton samples treated for 5 minutes in N₂ plasma at p=100 mTorr and P=50 W showed increase of K/S values around 600 nm with increment of the electrode distance. The highest K/S values, i.e. the best FCM adsorption were obtained for d=7cm.

Time-resolved recordings of plasma emission spectrum during treatments showed distinctive time dependence of N₂ spectral line intensities that appeared only when the cotton sample was present. This effect is due to the interaction which governs

activation of the surface, between excited N₂ molecules formed in plasma and the cotton surface. In Fig. 1 we show time evolution of N₂ 2nd positive system line intensity during treatments for different electrode gaps. The line intensities are normalized to their maximum values to facilitate the comparison.

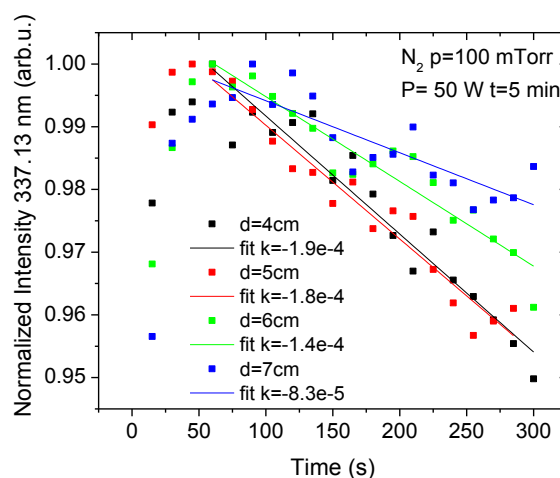

Fig. 1: Time development of normalized intensities of 337.13 nm N₂ 2nd positive system line at p=100 mTorr and P=50 W power with a cotton sample in the chamber

In series of treatments with optical and surface measurements we determined that the slope of the time evolution relates to the K/S values. Linear fits of the line intensity data show that lower slope coefficient (k) match to higher K/S values, with k=8.3·10⁻⁵ for d=7 cm where the best adsorption was attained.

Thus, for cotton treatments in N₂, time evolution of the 337 nm optical emission line proved to be a suitable parameter to follow the efficiency of cotton sample surface activation in the plasma treatment.

This work is supported by Ministry of Education, Science and Technological development of Serbia under project numbers ON171037 and III41011.

References

- [1] M Gorjanc V Bukošek, M Gorenšek, A Vesel 2010 Textile research journal 80.6 pp 557
- [2] D. Mihailovic, Z. Saponjic, R. Molina, N. Puač, P. Jovancic, J. Nedeljkovic, M. Radetic 2010 ACS applied materials & interfaces 2 (6) p 1700

PROCEEDINGS OF
THE XXIIND INTERNATIONAL
CONFERENCE ON GAS DISCHARGES
AND THEIR APPLICATIONS

- VOLUME 2 -

2nd - 7th September 2018

Novi Sad, SERBIA

Serbian Academy of Sciences and Arts
&
Institute of Physics, University of Belgrade

Editors: Prof. Zoran Lj. Petrović

Dr. Nevena Puač

Dr. Saša Dujko

Dr. Nikola Škoro

EXECUTIVE MANAGMENT COMMITTEE

Dr. J.E. Jones, Chair
Prof. G.R. Jones
Prof. J.W. Spencer
Prof. K Hidaka
Dr. A.B. Murphy
Prof. D. Hong
Dr. P. Robin-Jouan

INTERNATIONAL SCIENTIFIC COMMITTEE

Dr. J.-M. Bauchire, France	Dr. J.-P. Borra, France
Prof. Yann Cressault, France	Prof. M. Farzaneh, Canada
Prof. C.M. Franck, Switzerland	Prof. A. Haddad, UK
Prof. K. Hidaka, Japan	Prof. D. Hong, France
Prof. G.R. Jones, UK	Dr. J.E. Jones, UK
Dr. A.B. Murphy, Australia	Prof. Z. Lj. Petrović, Serbia
Prof. G.J. Pietsch, Germany	Prof. V. Rakov, USA
Prof. Ph. Robin-Jouan, France	Prof. A. Robledo-Martinez, Mexico
Prof. Kohki Satoh, Japan	Dr. M. Seeger, Switzerland
Prof. J.W. Spencer, UK	Dr. S. Stangherlin, Switzerland
Dr. T. Teich, Switzerland	Dr. Igor Timoshkin, UK
Prof. J. -Y. Trepanier, Canada	Prof. K.-D. Weltmann, Germany
Prof. Y. Wu, China	Dr. J. D. Yan, UK
Dr. J. L. Walsh, UK	

LOCAL ORGANIZING COMMITTEE

Prof. Zoran Lj. Petrović, Chair	Dr. Nevena Puač, Co-Chair
Dr. Saša Dujko, Co-Chair	Dr. Nikola Škoro, Secretary
Dr. Danko Bošnjaković	Prof. Bratislav Obradović
Dr. Dragana Marić	Dr. Gordana Malović
Kosta Spasić	Jelena Sivoš
Marija Puač	Dejan Maletić
Nenad Selaković	Jasmina Atić
Ilija Simonović	Vladan Simić

Panacomp Wonderland Travel

INFLUENCE OF ATMOSPHERIC PRESSURE PLASMA JET PARAMETERS ON DECONTAMINATION OF BACTERIA

A. JUROV^{1,2*}, U. CVELBAR², Z. LJ. PETROVIĆ³, N. ŠKORO³, K. SPASIĆ³, M. MODIĆ², N. HOJNIK^{1,2}, D. VUJOŠEVIĆ⁴, V. VUKSANOVIĆ⁴, AND M. ĐUROVIĆ⁴

¹ Jozef Stefan International Postgraduate School, Jamova cesta 39, 1000, Ljubljana, Slovenia

² Jozef Stefan Institute, Jamova cesta 39, 1000, Ljubljana, Slovenia

³ Institute of Physics, University of Belgrade, Pregrevica 118, 11080, Belgrade, Serbia

⁴ Center for Medical Microbiology, Institute of Public Health Montenegro, Džona Džeksona bb, 81000, Podgorica, Montenegro

*andrea.jurov@ijs.si

ABSTRACT

There are many new alternatives to conventional bacteria sterilisation techniques (heating, filtration, solvents, radiation), such as different plasma sources [1-4]. This research focused on non-thermal atmospheric pressure plasma jet (APPJ) because it's cost-effective, easily transportable, simple to use, and has a low operating temperature thus enabling treatment of heat sensitive surfaces.

The experiments were conducted with helium APPJ for four different typical bacteria strains (*Escherichia coli*, *Bacillus subtilis*, *Staphylococcus aureus*, and *Bacillus stearothermophilus*). The focus was on finding the most efficient discharge parameters; thus various input voltages and gas flows were tested. The analysis that was used on the jet is ICCD imaging, optical emission spectroscopy, and electrical measurements. Furthermore, the chemical analysis was done on treated medium (bacteria dispersed in saline) to detect the effectiveness of the decontamination.

1. INTRODUCTION

Improving the decontamination of the bacteria is an ongoing process and of great importance in many environments, such as hospitals. As an alternative to conventional techniques, plasma decontamination was proposed. Our choice was an atmospheric pressure plasma in a form of a

single electrode jet (APPJ). Atmospheric pressure plasmas have many advantages compared to low-pressure plasmas, mostly the ability to work without the vacuum system thus reducing the cost of the process and making it possible to treat heat-sensitive materials and hard-to-reach places (e.g. corners, tubes) [5,6]. Because of that we constructed the APPJ and tested its most optimal parameters for bacteria decontamination on four types of bacteria. After finding out which powers and gas flows decontaminated bacteria, the focus shifted onto the diagnostics of the plasma source - APPJ.

2. EXPERIMENTAL SETUP

The decontamination effect of the atmospheric pressure plasma jet was investigated on four different types of spore-forming bacteria: *Bacillus stearothermophilus* ATCC No. 7953, *Bacillus subtilis* ATCC No. 6633, *Staphylococcus aureus* ATCC No. 25923, and *Escherichia coli* ATCC No. 25922, of which only the *E. coli* is Gram-negative bacteria. Bacterial cultures were grown overnight on Columbia (COS) agar plates (bioMérieux SA, Marcy l'Etoile, France) at 55°C for *Bacillus stearothermophilus* and 37°C for *Bacillus subtilis*, *Staphylococcus aureus* and *Escherichia coli*. Bacteria were picked up with a loop and re-suspended in sterile saline to obtain 0.5 McFarland (1-2 x 10⁸ CFU/ml) initial bacterial suspension.

Small-size APPJ powered by a kHz signal source connected to a low-voltage DC source was used for the treatments. Measurements with the needle type APPJ were conducted with He as a working gas at a fixed distance between the jet and the sample surface (15 mm). Bacteria were treated for different gas flows (1 *slm* and 2 *slm*) and with several DC power supply voltages applied (3 V, 6 V, and 12 V). Detailed characterisation of the plasma source was performed employing optical measurements and electrical characterization.

3. RESULTS AND DISCUSSION

After preparing bacteria suspension, we treated them with Helium APPJ under different DC power supply voltages and gas flows. A surface of the suspension was fixed 15 mm under the jet nozzle, and it was fixed for all measurements. The bacteria suspension was placed in a Petri dish that was grounded.

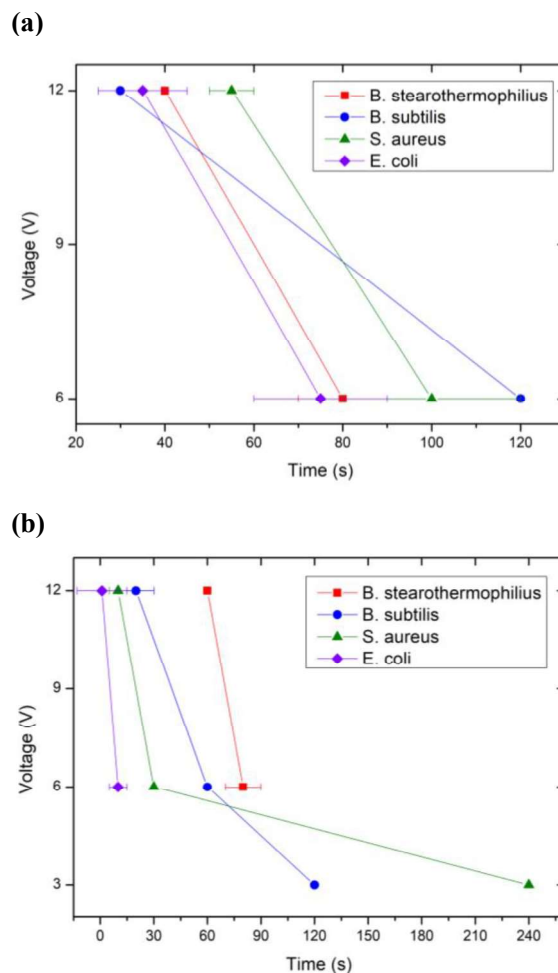

Fig. 1. Survival curves of all the bacteria for (a) 1slm and (b) 2slm

The survival curves of all the bacteria under this conditions are presented in Figure 1. These curves indicate that He APPJ with higher input power was more effective, meaning that the treatment time for decontamination is shorter for the higher power.

Once we have shown that this type of APPJ can decontaminate the bacteria, we started with the plasma source diagnostics. This was done under the same conditions as the bacteria were treated but over a Petri dish filled with distilled water (no bacteria). Petri dish was also grounded. The gas flow was 2 *slm*, and input power was 12 V.

The optical measurements include species detection with optical emission spectroscopy (OES) and ICCD imaging of the plasma streamer.

Figure 2 shows a complete spectrum of present species. It contains all expected species like OH, He, N and O atoms and molecules. He is present because it was used as working gas for the APPJ, and OH, N and O are present because the experiments were conducted in ambient air and in contact with distilled water. Additional spectrum was obtained, under the same conditions, where APPJ was in contact with the saline solution (not shown here). This spectrum showed no differences in comparison to the one shown in Figure 2 i.e. no existence of Na or Cl lines.

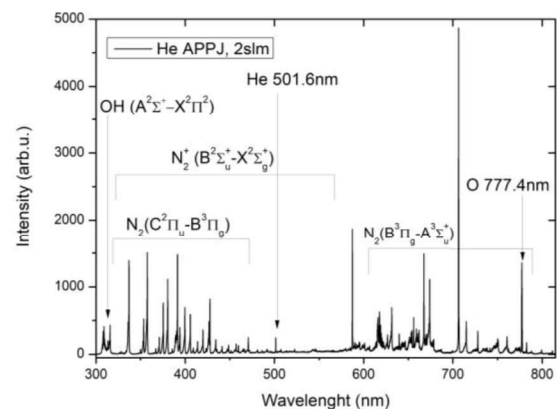

Fig. 2. OES of He APPJ (1cm from the surface of the distilled water in Petri dish (grounded))

As the second optical measurement of the APPJ we performed the ICCD imaging of the discharge. Selected images, shown in Figure 3, present length and thickness of the plasma streamer. The horizontal blue line in the images

represent the bottom of the APPJ (end of the glass tube) while the vertical orange line represents the wire electrode. It was found that the streamer reaches the surface of a distilled water for all conditions except for 1slm and 3 V. Thus, in the range of these conditions, the length of the streamer depends neither on voltage nor helium flow. On the contrary, the streamer width changes with applied voltage (from 0.66 mm for 3 V up to 1.92 mm for 12 V), but again it is not dependant on the gas flow. In all conditions investigated, the brightest region of the streamer is at the electrode tip which is expected due to the high electric field. The light intensity increases as driving voltage and gas flow increase.

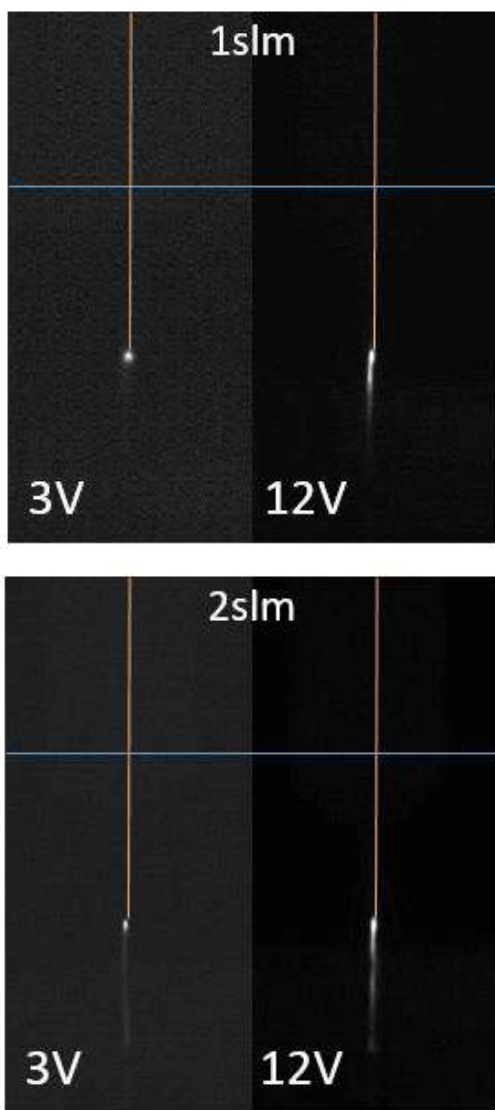

Fig. 3. ICCD images of discharges at different gas flows and input power. The horizontal blue line represents the bottom of the APPJ and the vertical orange line represents the wire electrode.

4. CONCLUSIONS

The decontamination effects of He APPJ were significant but dependent on the type of bacteria, exposure time, and plasma configuration (gas flow and input power). The input power of 3 V was not sufficient for bacteria decontamination when the gas flow was 1 slm; however, it was enough for decontamination of *S. aureus* and *B. subtilis* with the gas flow of 2 slm.

The optical emission spectrum showed that the plasma power was not sufficient enough to excite Na and Cl species, but it exhibits the intensive signature of OH, O and N species. Additional analysis will be done on specific atomic and molecular lines to observe their influence on the bacteria decontamination.

The ICCD imaging showed a spatial change of the plasma discharge and its invariance of the gas flow. Further calculations will provide us with the evaporation rate of the solution which should be taken into account for maintaining the distance from the APPJ nozzle to the surface of the bacteria solution.

ACKNOWLEDGEMENTS

This research is a part of NATO Science for Peace Multi-Year Project [SPS 984555], and ARRS project N3-0059.

REFERENCES

- [1] Ehlbeck J., Schnabel U., Polak M., Winter J., Von Woedtke T., et al., *Journal of Physics D: Applied Physics*, **44**, 1-33, 2011
- [2] Gadri R. B., Roth J. R., Montie T. C., Kelly-Wintenberg K., et al., *Surface and Coatings Technology*, **131**, 528-542, 2000
- [3] D. Vujošević, U. Cvelbar, U. Repnik, M. Modic, S. Lazović, et al., *Plasma Sci. Tech.*, **19** 075504-075513, 2017

- [4] A. Yu. Nikiforov, X. Deng, I. Onyshchenko, D. Vujosevic, V. Vuksanovic et al, Eur. Phys. J. Appl. Phys., 75, 24710-24717, 2016

- [5] Hofmann S., *Atmospheric pressure plasma jets: characterisation and interaction with human cells and bacteria*, Eindhoven: Technische Universiteit Eindhoven, 11-30, 2013

- [6] Halfmann H., Bibinov N., Wunderlich J., Awakowicz P., 'A double Journal of Physics D: Applied Physics, 40, 1-11, 2007

PROCEEDINGS OF
THE XXIIND INTERNATIONAL
CONFERENCE ON GAS DISCHARGES
AND THEIR APPLICATIONS

- VOLUME 2 -

2nd - 7th September 2018

Novi Sad, SERBIA

Serbian Academy of Sciences and Arts
&
Institute of Physics, University of Belgrade

Editors: Prof. Zoran Lj. Petrović

Dr. Nevena Puač

Dr. Saša Dujko

Dr. Nikola Škoro

EXECUTIVE MANAGMENT COMMITTEE

Dr. J.E. Jones, Chair
Prof. G.R. Jones
Prof. J.W. Spencer
Prof. K Hidaka
Dr. A.B. Murphy
Prof. D. Hong
Dr. P. Robin-Jouan

INTERNATIONAL SCIENTIFIC COMMITTEE

Dr. J.-M. Bauchire, France	Dr. J.-P. Borra, France
Prof. Yann Cressault, France	Prof. M. Farzaneh, Canada
Prof. C.M. Franck, Switzerland	Prof. A. Haddad, UK
Prof. K. Hidaka, Japan	Prof. D. Hong, France
Prof. G.R. Jones, UK	Dr. J.E. Jones, UK
Dr. A.B. Murphy, Australia	Prof. Z. Lj. Petrović, Serbia
Prof. G.J. Pietsch, Germany	Prof. V. Rakov, USA
Prof. Ph. Robin-Jouan, France	Prof. A. Robledo-Martinez, Mexico
Prof. Kohki Satoh, Japan	Dr. M. Seeger, Switzerland
Prof. J.W. Spencer, UK	Dr. S. Stangherlin, Switzerland
Dr. T. Teich, Switzerland	Dr. Igor Timoshkin, UK
Prof. J. -Y. Trepanier, Canada	Prof. K.-D. Weltmann, Germany
Prof. Y. Wu, China	Dr. J. D. Yan, UK
Dr. J. L. Walsh, UK	

LOCAL ORGANIZING COMMITTEE

Prof. Zoran Lj. Petrović, Chair	Dr. Nevena Puač, Co-Chair
Dr. Saša Dujko, Co-Chair	Dr. Nikola Škoro, Secretary
Dr. Danko Bošnjaković	Prof. Bratislav Obradović
Dr. Dragana Marić	Dr. Gordana Malović
Kosta Spasić	Jelena Sivoš
Marija Puač	Dejan Maletić
Nenad Selaković	Jasmina Atić
Ilija Simonović	Vladan Simić

Panacomp Wonderland Travel

VOLUME SCALING IN PRODUCTION OF ACTIVE OXYGEN SPECIES IN AN ASYMMETRICAL PLASMA REACTOR

K SPASIĆ*, N ŠKORO, N PUAĈ, G MALOVIĆ, Lj. PETROVIĆ

Institute of Physics, University of Belgrade, Pregrevica 118, 11080 Belgrade, Serbia

*kostasp@ipb.ac.rs

ABSTRACT

Large volume plasma reactor is created as a prototype of a device for industrial scale treatment of sensitive samples. Mild and streamer free plasmas can be achieved because of strong asymmetry of electrodes. We have investigated influence of surface of grounded electrode on creation of excited oxygen species. Measurements were performed by mass-energy analyser in oxygen-argon plasma at pressures of 300 mTorr, 450 mTorr and 600 mTorr.

1. INTRODUCTION

Low pressure plasmas are extensively used over wide spectrum of industries. Their biggest advantages are ease of control in processes such as etching or deposition [1] and relatively low price of application. They are used in textile industries in colouring preparations, where they have ecological advantage over traditional wet pre-treatments [2]. Also, they can make textiles more resistant to shrinkage or even render it bactericidal [3, 4]. Low pressure plasmas have lately been widely accepted for applications in biology, mostly in treatments of seeds. It is shown that plasma treatment of seed can lead to improvement of germination rate [5, 6], can affect enzyme activity [7] and even change the speed at which sprouts are growing [8]. Certain pathogens, fungi or bacteria, may appear on surface of seed weather during long term storage or even in the field. Plasmas are proven to be very effective tool in removal of those pathogens without damage to seeds [9, 10]

Prototype of a device that is suitable for low pressure plasma treatment of temperature sensitive samples have been created in our

laboratory. It is already shown to be successful in treatment of both seeds and textile [7, 11, 12].

Understanding of all discharge conditions and how they affect plasma parameters is very important in order to be able to create most effective and most energy efficient treatments. In order to gain better insight in relevant plasma chemistry, we have employed mass-energy analyser. In addition we have tested influence of surface of grounded electrode.8

2. EXPERIMENT

We have created large volume plasma reactor with asymmetric electrodes in order to provide streamer free conditions for industrial scale treatment of sensitive samples such as textiles or seeds. Cylindrically shaped discharge chamber, whose walls serve as a grounded electrode, is 2.5 m long and 1.17 m wide and it is made of stainless steel. Powered electrode, made of aluminium, is placed along the main axis of cylinder. It is 1.5 m long with diameter of 3 cm. Sample holding platform, which is also grounded, is placed 46 cm below powered electrode. For some measurements, additional stainless steel grounded electrode is placed around aluminium rod. It has outer diameter of 65 cm and it is grounded via contact with sample holding platform and additional contacts with chamber walls. Discharge is powered by Dressler Cesar 1310 power supply which is equipped with automatic matching box so that reflected power remains under 2% of forwarded power. It can deliver up to 1000 W at 13.56 MHz.

Gases are introduced into chamber over specially constructed home-made system which allows simultaneous control of up to 4 different gases. Desired mixture is achieved by setting up

appropriate flow of each component. In our experiments we have used mixture of 99% of oxygen and 1% of argon at pressures of 300 mTorr which was achieved with total flow of 220 sccm, 450 mTorr with flow of 400 sccm and 600 mTorr with 590 sccm. Low pressure is maintained by mechanical pump.

HIDEN EQP mass-energy analyser was placed side on into the chamber. Orifice of the device is positioned at a distance of 30 cm from powered electrode and it cannot be changed. When there was no additional grounded electrode in use mass-energy analyser protruded 25 cm from grounded wall toward powered electrode. In other case it was in level with grounded electrode.

During measurements of neutral species ionization had to be performed inside mass spectrometer. Energy of ionizing electrons can be adjusted with precision of 0.1 eV, starting from 4 eV. When mass spectra are recorded, this energy is fixed. Conversely, m/Z ratio can be fixed while measurements are performed as dependence of energy of ionizing electrons. Measurements that were performed at low RF power have low signal to noise ratio. In order to improve it 12 scans were performed for each condition.

3. RESULTS AND DISCUSSION

In order to better understand plasma chemistry in our discharge and to gain better insight in processes that are taking place on surface of treated samples, we have employed mass-energy analysis as a tool to detect presence of excited species of oxygen molecules and atoms. To achieve that, special measurement method had to be applied.

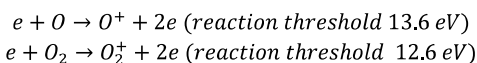

Table 1 Reaction thresholds for creating oxygen ions

Ionization of neutral species, which is necessary for their detection or any kind of manipulation, is happening inside mass spectrometer in ionization chamber by collision with ionizing electrons. These processes, presented in Table 1, have energy thresholds. If an atom or a molecule that is in ground state collide with an electron with energy that is below this threshold no ionization will take place and detection of these atoms or molecules will not be possible. Conversely, if some specie enters mass energy analyser in some

excited state it could be both ionized and detected after collision with an electron whose energy is below aforementioned threshold.

When discharge is turned off only ground state molecules are present and nothing is detected if energy of ionizing electrons is less than 12.6 eV. When discharge is turned on both excitation and dissociation can take place in plasma in various processes. Ionization and subsequent detection can now occur at energies that are well below threshold. Counting of excited species is performed by measuring counts for fixed ratio of m/Z at all energies up to an ionization threshold. Integrating that curve gives us number of all excited species at that m/Z that have entered mass energy analyser.

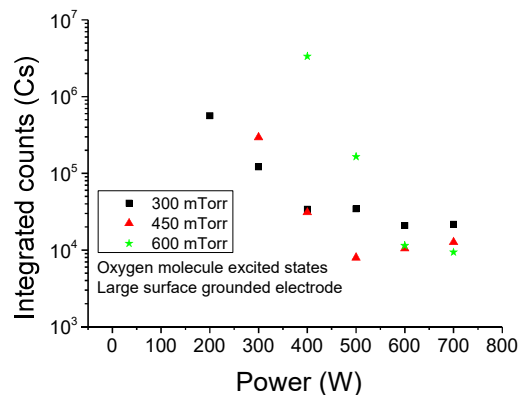

Fig. 1 Integrated counts of molecular oxygen species when larger grounded electrode was used

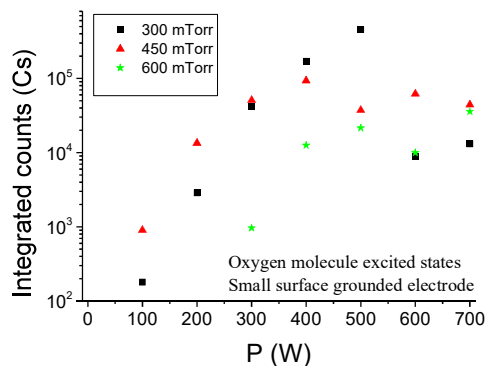

Fig. 2 Integrated counts of molecular oxygen species when smaller grounded electrode was used

Measurements were performed with grounded electrodes of two different sizes. Smaller electrode provides effective volume of plasma of 0.42 m³ while larger one stands at 1.53 m³. Integrated counts of molecular excited species are presented in Fig. 1. At low applied RF powers

counts were negligible. In order to detect neutral species higher powers should be applied at higher pressures. After initial detection further increase of power results in sharp decrease of excited species of molecular oxygen. This drop is most significant at the highest pressure where two orders of magnitude of reduction is observed. Behaviour like this can in part be attributed to increased dissociation of molecules at higher powers but also to increased ionization and excitation.

Excited species of molecular oxygen, when smaller grounded electrode was used, are presented in Fig. 2. Much lower counts were recorded in this case. Since mass spectrometer is in level with grounded electrode huge loss of excited species is taking place on surface of that electrode. At all tree pressures higher applied power caused increase in number of excited species up to a pressure dependent maximal value. Further increase of power is leading to a drop in their numbers, which is very similar to one that was exhibited when larger electrode was used.

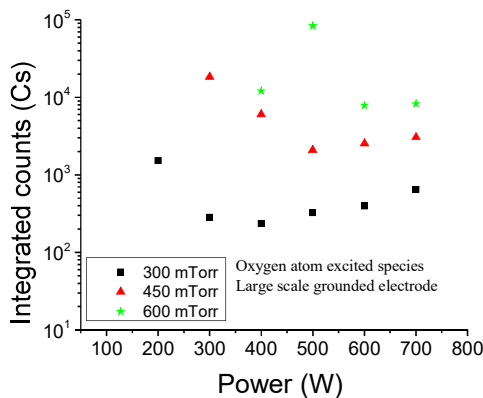

Fig. 3 Integrated counts of atomic oxygen species when larger grounded electrode was used

Integrated counts of atomic oxygen excited species, for situation when larger grounded electrode was used are shown in Fig. 3. Their behaviour is similar to species of molecular oxygen when larger grounded electrode was used. There is certain minimal power that is required to be applied below which no detection is taking place. This detection threshold is pressure dependent and it is higher at higher pressures. At 300 mTorr and 450 mTorr rise of applied power is causing number of excited species to, at the beginning, sharply drop to a minimum value. After that point growing trend can be observed.

Only at 600 mTorr maximal number of excited species were detected at power that is higher than detection threshold.

In Fig. 4 we present integrated counts of excited atomic oxygen species when smaller grounded electrode was used. In contrast to behaviour with larger electrode higher counts are measured at lower pressures. Due to the fact that orifice of the mass spectrometer stands at level of the surface of grounded electrode which is depleting oxygen atoms, very low counts of excited species are measured. In addition detection was not possible at all when applied power was under 400 W. General rising trend is observed with increase of RF power but in order to create significant amount of atomic species, which would be effective in any kind of treatment one would need to apply RF powers that are beyond our technical capabilities.

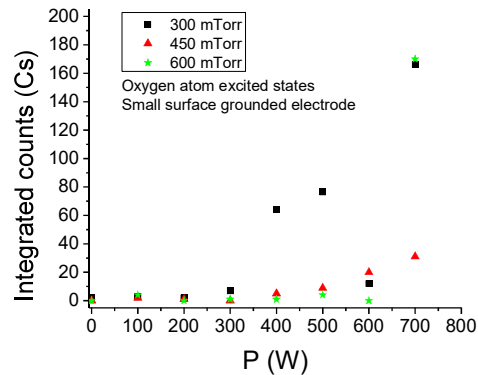

FIG. 4 Integrated counts of atomic oxygen species when smaller grounded electrode was used

4. CONCLUSIONS

We have tested influence of surface of grounded electrode in highly asymmetrical system on creation of excited species of oxygen. Measurements were performed at the same distance from powered electrode. Smaller grounded electrode is constructed as cylinder and its surface is at the same distance from powered electrode as mass-energy analyzer. Much higher production of excited species was achieved when larger grounded electrode was used.

REFERENCES

[1] T. Makabe and Z. Lj. Petrovic, PLASMA ELECTRONICS: Applications in Micro

- Electronic Device Fabrication, Taylor & Francis Group, (2006)
- [2] Radetic M, Jovancic P, Puac N, Petrovic ZL. Environmental impact of plasma application to textiles. In *Journal of physics: conference series* 2007 (Vol. 71, No. 1, p. 012017). IOP Publishing.
- [3] Sun D. and Stylios G.K., *Textile research journal* (2004), 74, 9, 751-756.
- [4] Radetic M, Jovancic P, Puac N, Petrovic, *Journal of physics: conference series* (2007), 71, 1, 012017
- [5] Kitazaki S, Koga K, Shiratani M, Hayashi N. Growth enhancement of radish sprouts induced by low pressure O₂ radio frequency discharge plasma irradiation. *Japanese Journal of Applied Physics*. 2012 Jan 20;51(1S):01AE01.
- [6] Filatova I, Azharonok V, Gorodetskaya E, Mel'nikova L, Shedikova O, Shik A. Plasma-radiowave stimulation of plant seeds germination and inactivation of pathogenic microorganisms. *Proceedings of the International Plasma Chemistry Society*. 2009 Jul;19:627
- [7] Puač N, Škoro N, Spasić K, Živković S, Milutinović M, Malović G, Petrović ZL, *Plasma Processes and Polymers* (2017), 1700082
- [8] Volin JC, Denes FS, Young RA, Park SM, *Crop Science* (2000), 40, 6, 1706-18
- [9] Nishioka T, Takai Y, Kawaradani M, Okada K, Tanimoto H, Misawa T, Kusakari S. Seed disinfection effect of atmospheric pressure plasma and low pressure plasma on *Rhizoctonia solani*. *Biocontrol science*. 2014;19(2):99-102.
- [10] Schnabel U, Niquet R, Krohmann U, Winter J, Schlüter O, Weltmann KD, Ehlbeck J. Decontamination of microbiologically contaminated specimen by direct and indirect plasma treatment. *Plasma Processes and Polymers*. 2012 Jun 1;9(6):569-75.
- [11] S. Živković, N. Puač, Z. Giba, D. Grubišić, Z.Lj. Petrović, *Seed Science and Technology*, 32 3 (2004) 693
- [12] N. Puač, Z.Lj. Petrović, M. Radetić, A. Djordjević, *Materials Science Forum* 494 (2005) 494

Activity of Catalase Enzyme in *Paulownia Tomentosa* Seeds as a Result of a Direct and Indirect Treatment by the Non-Equilibrium Plasma

Nevena Puač¹, Nikola Škoro¹, Kosta Spasić¹, Suzana Živković², Milica Milutinović², Gordana Malović¹ and Zoran Lj. Petrović^{1,3}

¹ Institute of Physics, University of Belgrade, Pregrevica 118 11080 Zemun, Belgrade Serbia
zoran@ipb.ac.rs

² Institute for Biological Research "Siniša Stanković", University of Belgrade, Bulevar despota Stefana 142, 11060 Belgrade, Serbia

³ Serbian Academy of Sciences and Arts, Knez Mihajlova 35, 11001 Belgrade Serbia

In this work we present results of two different approaches to plasma treatment of seeds. In the first (direct), *Paulownia tomentosa Steud.* seeds were directly treated by a low-pressure plasma and then imbibed with distilled water. The low pressure plasma treatment was shown to give excellent results in improvement of germination of these seeds [1]. In the second approach (indirect), an atmospheric pressure plasma was used to produce plasma activated water (PAW) which is then used for imbibition of seeds.

Recent advances in atmospheric pressure non-equilibrium plasmas were mainly motivated by the biomedical applications [2]. In addition to the plasma medicine the second major area of application is the use of plasmas in agriculture, food industry and related technologies. One of the first and most important developments was the plasma induced increase of germination probability [1]. The need to understand the mechanisms responsible for the plasma induced effects on germination are the motivation for the present research. In addition we can compare two different methods of applying plasma to the seeds. These results will allow us to correlate the enzyme activity and the protein content during the initial stages of germination depending on plasma treatment and conditions.

As opposed to the regular water, Plasma Activated Water (PAW) contains chemically active species (OH, O, NO, H, H₂O₂, NO₂⁻, O₂⁻, NO₃⁻, OH⁻) produced in plasma and at the plasma-liquid interface and transferred into the liquid [3]. A low pressure radio-frequency (RF) plasma was used for direct treatment of seeds while an atmospheric pressure plasma jet (APPJ) was used to obtain PAW. We have followed an early phase of germination, up to 3 days after the phytochrome activation. Catalase (CAT, EC 1.11.1.6) is a tetrameric protein found in all aerobic organisms that catalyzes the dismutation of H₂O₂ into water and oxygen. CAT enzyme protein content and activity were measured for several days. CAT is one of the most important antioxidant defenses in living cells. We have chosen optimum parameters for germination for direct plasma treatments. We have measured both CAT protein content and CAT enzyme activity at the beginning of the germination process and over the three subsequent days

In this paper we show results of CAT enzyme activity and protein content obtained during the second phase of germination of *P. tomentosa* seeds (phase of phytochrome activity). With

low pressure plasma we have a lot of experience in establishing beneficial effects of plasma on germination. When it comes to the use of APPJ obtain PAW we made sure that pH and dissolved oxygen content were measured immediately after the treatment. pH was not allowed to change significantly and it stayed within the 6.5-7 range. Thus we could safely claim that germination and subsequent protrusion of radicle were not influenced by the change in pH. At the same time percentage of dissolved oxygen in the PAW was significantly decreased up to 40% compared to untreated water. This could have a detrimental effect on germination percentage, radicle protrusion resulting in a slow early seedling growth and development.

Both plasma treatments used in this study caused a decrease in CAT activity/protein content in seeds (as compared to the control samples) in the time period up to 2 days after the germination inducing light pulse. The actual reduction could be associated with the treatment times and pressures, in case of the low-pressure direct treatments. For indirect PAW treatment, the distances between the glass tube of the jet and the water surface affected results the most.

Differences in CAT activity/content noticed 6 days after the start of imbibition strongly suggest that approximately 48 hours after the R pulse *P. tomentosa* seeds enter the 3rd phase of germination. It is the phase of radicle protrusion and elongation, i.e. germination is terminated and postgermination processes develop [4].

- [1] S. Živković, N. Puač, Z. Giba, D. Grubišić and Z.L.J. Petrović, *Seed Science and Technology*, **32**, 693 (2004).
- [2] I Adamovich, S D Baalrud, A Bogaerts, P J Bruggeman, M Cappelli, V Colombo, U Czarnetzki, U Ebert, J G Eden, P Favia, D B Graves, S Hamaguchi, G Hieftje, M Hori, I D Kaganovich, U Kortshagen, M J Kushner, N J Mason, S Mazouffre, S Mededovic Thagard, H-R Metelmann, A Mizuno, E Moreau, A B Murphy, B A Niemira, G S Oehrlein, Z Lj Petrovic, L C Pitchford, Y-K Pu, S Rauf, O Sakai, S Samukawa, S Starikovskaia, J Tennyson, K Terashima, M M Turner, M C M van de Sanden and A Vardelle, *J. Phys. D: Appl. Phys.* **50** (2017) 323001 (46pp)
- [3] P.J. Bruggeman, M.J. Kushner, B.R. Locke, J.G.E. Gardeniers, W.G. Graham, D.B. Graves, R.C.H.M. Hofman-Caris, D. Maric, J.P. Reid, E. Ceriani, D. Fernandez Rivas, J.E Foster, S.C. Garrick, Y. Gorbanev, S. Hamaguchi, F. Iza, H. Jablonowski, E. Klimova, J. Kolb, F. Krcma, P. Lukes, Z. Machala, I. Marinov, D. Mariotti, S. Mededovic Thagard, D. Minakata, E.C. Neyts, J. Pawlat, Z.L. Petrovic, R. Pflieger, S. Reuter, D.C. Schram, S. Schröter, M. Shiraiwa, B. Tarabová, P.A. Tsai, J.R.R. Verlet, T. von Woedtke, K.R. Wilson, K. Yasui and G. Zvereva, *Plasma Sources Sci. Technol.* **25**, 53002 (2016).
- [4] D. Grubišić, M. Nešković, and R. Konjević, *Plant science*, **39**, 13 (1985).

Biomedical applications and diagnostics of atmospheric pressure plasma

This article has been downloaded from IOPscience. Please scroll down to see the full text article.

2012 J. Phys.: Conf. Ser. 356 012001

(<http://iopscience.iop.org/1742-6596/356/1/012001>)

View [the table of contents for this issue](#), or go to the [journal homepage](#) for more

Download details:

IP Address: 150.108.161.71

The article was downloaded on 07/01/2013 at 20:17

Please note that [terms and conditions apply](#).

Biomedical applications and diagnostics of atmospheric pressure plasma

Z Lj Petrović¹, N Puač, S Lazović, D Maletić, K Spasić and G Malović

Institute of Physics, University of Belgrade, Pregrevica 118, 11080 Belgrade, Serbia

E-mail: zoran@ipb.ac.rs

Abstract. Numerous applications of non-equilibrium (cold, low temperature) plasmas require those plasmas to operate at atmospheric pressure. Achieving non-equilibrium at atmospheric pressure is difficult since the ionization growth is very fast at such a high pressure. High degree of ionization on the other hand enables transfer of energy between electrons and ions and further heating of the background neutral gas through collisions between ions and neutrals. Thus, all schemes to produce non-equilibrium plasmas revolve around some form of control of ionization growth. Diagnostics of atmospheric pressure plasmas is difficult and some of the techniques cannot be employed at all. The difficulties stem mostly from the small size. Optical emission spectroscopy and laser absorption spectroscopy require very high resolution in order to resolve the anatomy of the discharges. Mass analysis is not normally applicable for atmospheric pressure plasmas, but recently systems with triple differential pumping have been developed that allow analysis of plasma chemistry at atmospheric pressures which is essential for numerous applications. Application of such systems is, however, not free from problems. Applications in biomedicine require minimum heating of the ambient air. The gas temperature should not exceed 40 °C to avoid thermal damage to the living tissues. Thus, plasmas should operate at very low powers and power control is essential. We developed unique derivative probes that allow control of power well below 1 W and studied four different sources, including dielectric barrier discharges, plasma needle, atmospheric pressure jet and micro atmospheric pressure jet. The jet operates in plasma bullet regime if proper conditions are met. Finally, we cover results on treatment of bacteria and human cells as well as treatment of plants by plasmas. Localized delivery of active species by plasmas may lead to a number of medical procedures that may also involve removal of bacteria, fungi and spores.

1. Introduction

The choice of the plasma system used for treatment is usually guided by the kind of samples that are treated and the effect these plasmas are intended to have on the samples. The desire to use plasma for in-vivo treatments have made it necessary that several requirements for plasma sources be met. Necessarily, plasmas have to operate at atmospheric pressure if they are to be used for medical treatment of living organisms. At the same time, one needs non-equilibrium plasmas in order to achieve separation of electrons on the one side, and ions and neutrals, on the other. It is an advantage that no expensive vacuum systems are needed, while, on the other hand, it is much more difficult to achieve non-equilibrium (non-thermal) mode of operation at higher pressures.

¹ To whom any correspondence should be addressed.

The sensitivity to heat of biomedical samples narrows the choice of non-thermal plasmas. There are many types of plasmas that can be generated under ambient pressure and temperature conditions suitable for treatment of sensitive samples [1, 2, 3]. The motivation is to develop new medical techniques, as plasma offers some possibilities for inducing desired processes with minimum damage to the living tissue [1, 2, 3, 4]. While the first results seemed quite impressive, including effects on tumor cells and even active tumors [5], tooth decay treatment and tooth cleaning [6], wound healing [5], treatment of fungi and spores and even treatment of ulcers and blood vessels, one can still not rule out negative effects that have not been studied over a sufficiently long time scale. The preliminary results, however, show a large degree of selectivity.

Some of the well-known small-size atmospheric-pressure plasma sources are: plasma needle [7, 4], μ APPJ [8], plasma bullet [9], plasma torch [10] and floating electrode dielectric barrier discharge plasma [11]. Their electrode configuration, voltages and excitation frequencies are very different; some of them work at microwave frequencies, some at 13.56 MHz and others at 5-120 kHz in sine or pulse regime. Yet, all is not understood about their physics and while models are being developed mainly based on low pressure plasmas, the reliable experimental data are limited due to the limited availability of diagnostic techniques that are suited for such plasmas.

Here we will present several diagnostics techniques suited for atmospheric pressure plasmas and the operation of several different plasma systems working at atmospheric pressure. We will also summarize our results in treating living organisms and give examples of results mainly on sterilization of bacteria and biofilms.

2. Atmospheric pressure discharges – different experimental set-ups

Achieving non-equilibrium at atmospheric pressure is difficult since the ionization growth is very fast at such a high pressure. The high degree of ionization on the other hand enables transfer of energy between electrons and ions through Coulomb collisions. Furthermore, heating of the background neutral gas is achieved through collisions between ions and neutrals. Thus, all schemes to produce non-equilibrium plasmas revolve around some form of control of the ionization growth. It can be achieved either by an inhomogeneous field as in corona or by employment of a dielectric barrier which turns the field off after a space charge is deposited on the dielectric. Ionization growth limiting may also be achieved by a time-varying field. Another approach is to operate at the pd value corresponding to the Paschen minimum, i.e. at microscopic dimensions and high pressures. In that case, the breakdown voltage is below the threshold for streamer development and thus a glow discharge may be achieved. If the electronegative nature of the gas is increasing the breakdown and operating voltages, one may mix in an inert gas. The discharge is thus initiated in the inert gas and then the atmospheric gas is mixed to produce chemically active radicals. In most cases, however, atmospheric pressure plasmas have small dimensions making it very difficult to perform standard diagnostics.

Some of the plasma devices designed for in-vivo treatments are the μ -APPJ and the plasma needle, which operate at 13.56 MHz at atmospheric pressure. A micro-atmospheric plasma jet was developed by Schultz van der Gathen and coworkers [12]; this plasma source is interesting both for applications as well as for the study of its basic properties.

The micro-atmospheric pressure plasma jet [μ -APPJ] consists of two symmetrical electrodes of equal length (34 mm) made of stainless steel. The distance between the electrodes can be adjusted with good precision from a few mm up to several hundred micrometers. In all our experiments, the distance between the powered and the grounded electrode was 1 mm. One of the electrodes was powered by a signal generator at 13.56 MHz while the other electrode was grounded. The measurements were made at powers of 40-80 W fed by a RF power supply.

Plasma is ignited along the entire length of the electrodes (figure 1); for certain combinations of power/gas-flow parameters, effluent of plasma coming out of the cuvette can be formed. The main advantage of this design is that both the discharge volume (plasma core) and effluent region are accessible for diagnostics, such as optical emission spectroscopy (OES) and two-photon absorption

laser-induced fluorescence (TALIF) [8]. Also, the plane parallel geometry of the electrodes adds to the simplicity when it comes to modeling this type of discharge.

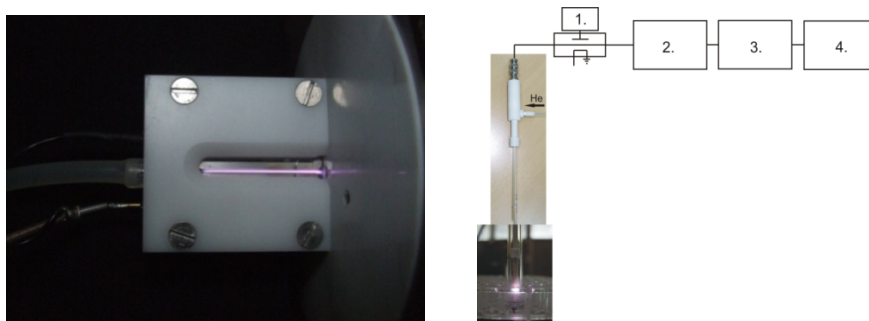

Figure 1. μ -APPJ with formed plasma and plasma needle system set-up.

Another plasma source that meets all the necessary conditions for treatment of organic materials and living tissues is the plasma needle (figure 1, picture on the right-hand side). Most importantly, in such a discharge gas the heating is minimized, while the effects on the tissue and bacteria have been clearly shown to be significant. The needle consists of a central electrode made of tungsten insulated almost to the tip by a slightly larger ceramic tube, both being placed inside a glass tube. The needle body is made of Teflon. We used helium as a buffer gas at several different flow rates. The central electrode is powered by a 13.56 MHz signal generator through an amplifier and a matching network. Both for the plasma needle and for the μ -APPJ, we have derivative probes and a Hiden HPR60 mass/energy analyzer in order to determine the power applied to plasma and the composition of the discharge, respectively. In both of these systems, inert gas is used to reduce the breakdown voltage and achieve stable non-equilibrium plasma formation. Yet these plasmas have shown several modes of operation and further studies are required to fully understand their operation and make further optimizations.

Another type of atmospheric pressure plasma relies on mixing the inert gas carrying the plasma created by external electrodes with atmospheric gas mixture. It is the so-called plasma jet. The operating frequencies of plasma jets are in the region of several tens of kHz which are much lower frequencies than those used for the plasma needle and μ -APPJ (in MHz). It has been shown that micro jet plasma is not always continuous but often is formed by a train of fast travelling bullets which only appear to be continuous to the human eye. The atmospheric pressure plasma jet/bullet that we constructed was made of a Pyrex glass tube with the electrodes made of a thin copper foil wrapped around the glass tube. The distance between the powered and the grounded electrode was 13.5 mm and their width was 13 mm. One of the electrodes (the left electrode, see figure 2) was grounded. The other electrode, closer to the end of the glass tube, was the powered one (see figure 2). In all experiments the buffer gas was helium. We used a signal generator connected to the custom-made amplifier to power the micro jet. The highest voltages that we could obtain from the amplifier were up to 1 kV, which was not enough to ignite the plasma. In order to increase the applied voltages to more than 5-6 kV, we had to use an additional homemade transformer. The operating frequency was 80 kHz and the applied voltage was sinusoidal in the range of 6-10 kV_{peak-to-peak}. Micro jets with plasma bullets have been constructed with a range of different

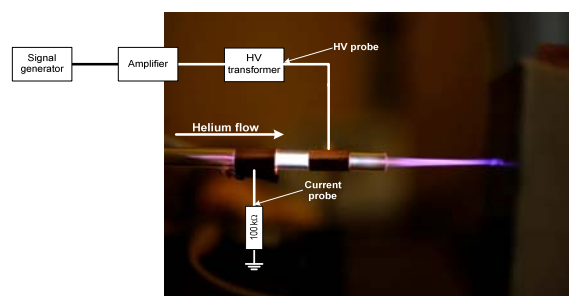

Figure 2. Atmospheric plasma bullet.

geometries, frequencies and shapes of applied voltage. The effect of bullets seems to be quite universal for an optimum range of electrode sizes and flows, while the frequencies and voltage shapes vary a lot. Plasma bullets, however, still need to be fully understood and properly modelled. We will focus here on the plasma jet diagnostics, while at the same time showing some results on the sterilization achieved by a plasma needle.

3. Plasma diagnostics

It has been reported only quite recently that the plasma jets formed by the source operating at low excitation frequency is not continuous. Instead it consists of small plasma packages that are formed in positive and/or negative half cycle of the period [13]. Amazingly these little bullets are formed and travel outside the plasma jet where there is no applied electric field. The velocity of these packages are larger than the speed of the flowing feed gas by several orders of magnitude. Several theories of bullet formation have been proposed [13, 14, 15, 16, 17, 18] but to date a definite explanation of the physical mechanisms involved in creation and propagation of plasma bullet are still not fully understood.

For the current and voltage measurements, we used two commercial probes. The current and voltage waveforms when the plasma is formed and without discharge are shown in figure 3. When the plasma is off, the phase difference between the current and voltage is close to 90° . In this case, we have a capacitive impedance of several $M\Omega$, corresponding to a capacitance of about 0.5 pF. On the other hand, when the plasma is formed, the current signal is larger, deformed and shifted in phase overlapping more with the voltage signal. The plasma ignition changes the slopes of the V_{RMS} - I_{RMS} curves (see figure 4). The mean power calculated increases with the increase of the applied voltage; it was in the range from 1 to 8 W in all measurements.

Integral and time-resolved images of the plasma jet system were obtained by an ICCD camera. For exposure times larger than the cycle period ($12.5 \mu s$), the plasma appears to be continuous, like a plume (see figure 1 LHS picture). The length of the plasma plume is up to five centimeters, depending of the flow rate and the voltage applied. For the time-resolved images, we had to use integration on the chip because the light emission in a single shot is not sufficient to obtain clear images with gate widths less than 50 ns. This was facilitated by the high reproducibility of the pulses and the small jitter. Figure 5 shows the plasma bullet images obtained for several different flows of working gas. We can see that with the decrease in the He flow, the plasma bullet starts to be elongated, deformed and its intensity is much smaller. Eventually, bullets are not formed at the very small flows.

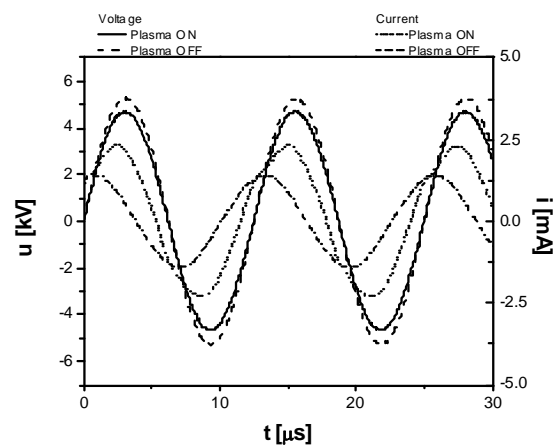

Figure 3. Current and voltage waveforms for helium flow rate of 3 slm. The dashed lines represent the case when discharge is OFF, the solid lines, when discharge is ignited [19].

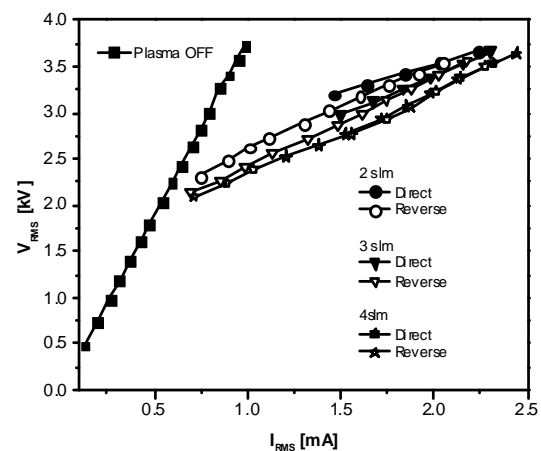

Figure 4. Current-voltage characteristics for three different flows of helium [19].

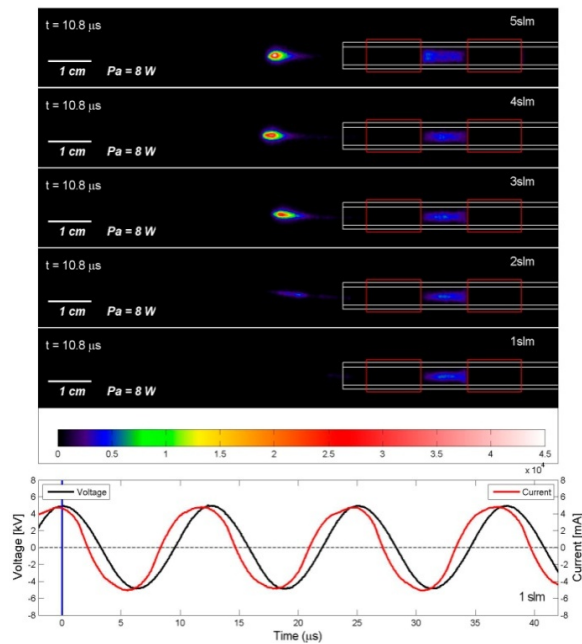

Figure 5. Plasma jet for 1, 2, 3, 4 and 5 slm of He flow. Exposure time 2 ms, gate width 25 ns, gate delay 10.8 μs [19].

Figure 6 shows the development of the plasma over the entire period of applied voltage (12.5 μs). All images are scaled to the same maximum intensity and thus can be compared. One can see that when the current and voltage signals are close to zero, the plasma is not visible. In the negative part of the current and voltage waveforms, the plasma is confined between the electrodes. During the positive part of the waveforms, the plasma is first confined between the electrodes (rising slope) and then, near the maximum of the curves, it leaves the glass tube in the form of a bullet. The dimensions of the bullet are of the order of a few millimeters. We calculated the speed of the bullet at ~ 20 km/s, depending on the position away from the end of the glass tube. The plasma bullet is much faster than the speed of the buffer gas flow (1 to 7 m/s). Thus we can conclude that our plasma source was not continuous, it consisted of very small plasma packages that traveled at a high speed. By varying the plasma parameters, the length and intensity of the plasma coming out of the tube can be adjusted.

For the two plasma devices operating at a much

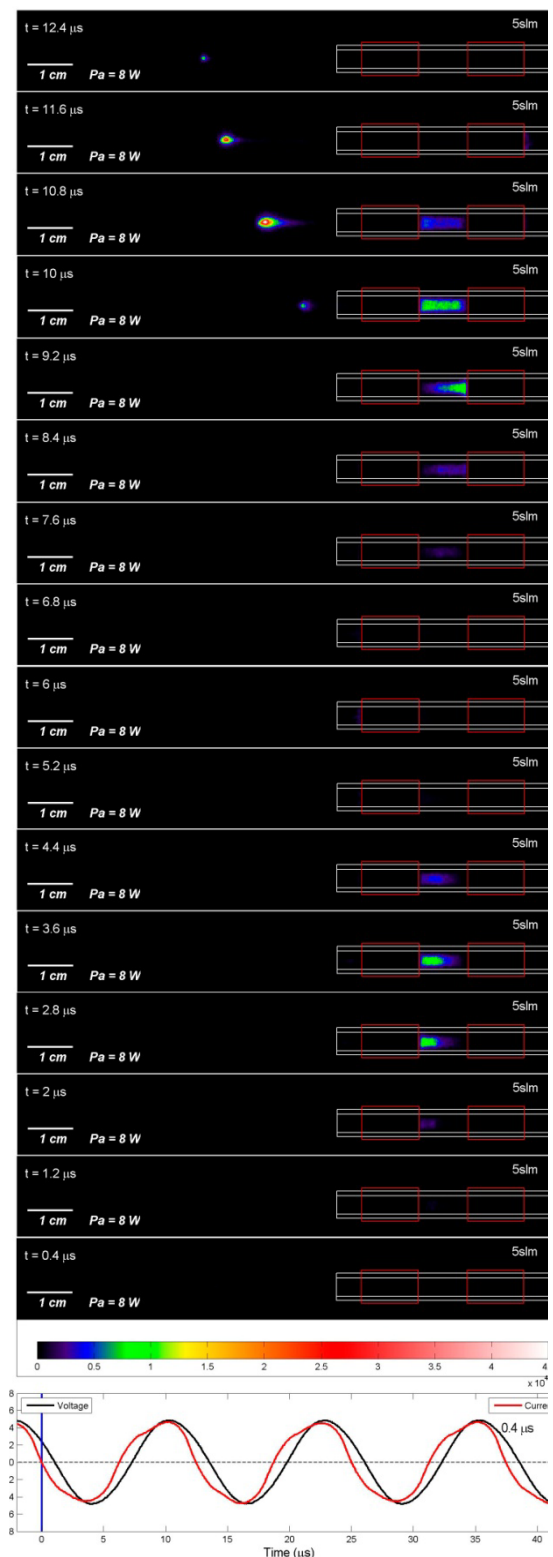

Figure 6. Plasma jet at 5 slm, exposure time 2 ms, gate width 25 ns and gate delay from 0.4 to 12.4 μs [19].

higher frequency (13.56 MHz), the diagnostics was made by using homemade derivative probes in order to determine the power transmitted to the plasma and the operation mode of the discharge. The derivative probes were very sensitive; a numerical procedure for subtracting the displacement current based on accurate calibration of the system was performed so that it was possible to measure powers of the order of 0.1 W or less even with displacement current a couple of orders of magnitude larger than the plasma current.

Besides derivative probes, we used mass spectrometry to analyze the plasma products formed by a μ -APPJ [19] and by a plasma needle [20]. Several problems occurred during the setting up of the experiment; they are described in detail elsewhere [19, 20].

The analysis of the composition of neutrals and ions was motivated by the need to check which species are formed in the discharge. These results may be used as a test of plasma chemical models, to identify radicals and ions (that may be used after acceleration to induce damage to the tissue). The performance of the mass analyzer was tested and techniques were developed to produce data without the uncertainty induced by a contribution of the ionizer to possible dissociation. It was found that the predominant ions created by the plasma are O_2^+ , O^+ , H_3O^+ , N_2^+ , N^+ , NO^+ , OH^+ [19]. When it comes to plasma treatment of samples of biological origin, the chemically active species that are of interest are O, metastables O and O_2 , OH, N, H_2O_2 and NO.

4. Plasma sterilization

The entry point for most groups dealing with plasma medicine is a study of sterilization. The effects on bacteria may be shown quickly, although it requires expertise in biomedicine. The benefit is that direct potential applications may be developed outside the realms of strict medical regulations. Yet, in situ sterilization, for example, treatment of wounds to prevent infection, would be a much more important goal. Following preliminary work on sterilization in microwave plasma, albeit at low pressure, we reinitiated the studies of plasma sterilization as a part of our plasma medical project. So far, a plasma needle has been used to induce killing of *Streptococcus mutans* and *Escherichia coli* bacteria in the form of planktonic samples. Also, we have the plasma interaction with normal, living cells; for these experiments we used human peripheral blood mesenchymal stem cells (hPB-MSC) as a model system to predict the degree of possible damage to the cell responses [21]. Many factors are responsible for bacterial inactivation. Direct exposure of the bacterial samples to the plasma appears to be more effective than remote exposure. Another factor that determines the efficiency of the specific treatment is the type [22] of bacteria, gram positive or gram negative. Very importantly, we studied the sterilization of bacteria in planktonic samples, where bacteria are dissolved in a small amount of liquid that would otherwise give it some protection from other agents. We showed that efficient sterilization of planktonic samples is not only possible, but may be efficient depending on the initial population [21].

One of the most serious problems in the hospital environment is bacterial contamination of surfaces with methicillin-resistant *Staphylococcus aureus* (MRSA) responsible for significant nosocomial infections. The pathogenic contaminants form biofilms, which are difficult to treat with routine biocides. The biofilm is not just a secured shelter

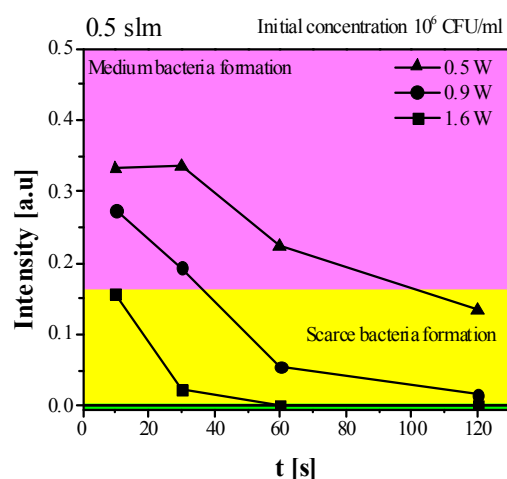

Figure 7. Treatment of MRSA biofilms of *Staphylococcus aureus* (ATCC 25923) by using plasma needle. Untreated sample showed STRONG bacteria formation (control intensity 0.65 a.u.). Initial concentration of bacteria used was 10^6 CFU/ml.

but a defense mechanism and a nutrition depot for pathogens. We show below the preliminary results of plasma treatment of the MRSA bacteria samples in the form of a biofilm.

In figure 7, we show the optical density of bacteria samples after plasma treatment for several different treatment times (10, 30, 60 and 120 s). The initial concentration of the samples was 10^6 CFU/ml, which corresponds to a measured optical density of 0.65 a.u. The buffer gas flow was 0.5 slm, but studies were also made as a function of the flow rate. The treatment efficiency increases with the increase of the treatment time and the mean power deposited to the plasma. For the highest power and only for the shortest treatment time of 10 s, there was scarcely bacteria formation; for the longer treatment, no bacteria formation was observed after the plasma treatment and yet there was very little or no heating of the gas.

Conclusions

We reviewed shortly our studies of atmospheric pressure plasmas and their application in biomedicine. In particular, we covered new results obtained with a plasma jet showing formation of plasma bullets and their properties as a function of geometry of electrodes and gas flow. In addition, we showed some practical results of sterilization using a plasma needle. The treatment of biofilms is essential, as are the studies of treatment of fungi, spores, prions and viruses. At the same time, one needs to extend the studies to specific medical problems associated with treatment of living organisms, including humans.

As far as plasma goes, some further optimization may be made for localized accurate treatment of cells or sterilization. With good knowledge of the power deposited into the plasma and control of the radicals that are produced, together with spatial emission profiles indicating changing of the regime of operation, a sufficient control over the reproducibility of the plasma needle operation was achieved. Other sources may be sought for more refined interaction with living cells. Different applications may seek more uniform sources extended over larger areas or even more localized treatment, which is all within the reach of the present day techniques.

Acknowledgements

This research has been supported by the MES, Serbia, under contract numbers ON171037 and III41011.

References

- [1] Fridman A and Kennedy L A 2004 *Plasma Phys. Eng.* (New York: Taylor and Francis)
- [2] Iza F, Kim G J A, Lee S M A, Lee J K A, Walsh A J, Zhang A Y and Kong M 2008 *Plasma Process. Polym.* **5** 322
- [3] Stoffels E, Flikweert A J, Stoffels W W, and Kroesen G M W 2002 *Plasma Sources Sci. Technol.* **11**/4 383
- [4] Puač N, Petrović Z Lj, Malović G, Đorđević A, Živković S, Giba Z and Grubišić D 2006 *J. Phys. D: Appl. Phys.* **39** 3514-19
- [5] Fridman G, Friedman G, Gutsol A, Shekhter A B, Vasilets V N and Fridman A 2008 *Plasma Process. Polym.* **5** 503-33
- [6] Sladek R E J, Stoffels E, Walraven R, Tielbeek P J A and Koolhoven R A 2004 *IEEE Trans. Plasma Sci.* **32**/4 1540-3
- [7] Kieft I E, v d Laan E P and Stoffels E 2004 *New J. Phys.* **6** 149
- [8] v d Gathen S V, Schaper L, Knake N, Reuter S, Niemi K, Gans T and Winter J 2008 Spatially resolved diagnostics on a microscale atmospheric pressure plasma jet *J. Phys. D: Appl. Phys.* **41** 194004
- [9] Shi J, Zhong F, Zhang J, Liu D W and Kong M G 2008 *Phys. Plasmas* **15** 013504
- [10] Yonson S, Coulombe S, Leveille V and Leask R L 2006 *J. Phys. D: Appl. Phys.* **39** 3508-13
- [11] Fridman G, Shereshevsky A, Jost M M, Brooks A D, Fridman A, Gutsol A, Vasilets V and Friedman G 2007 *Plasma Chem. Plasma Process.* **27** 163-176
- [12] v d Gathen S V, Buck V, Gans T, Knake N, Niemi K, Reuter St, Schaper L and Winter J 2007

Contrib. Plasma Phys. **47/7** 510

- [13] Walsh J L and Kong M G 2008 *IEEE Trans. Plasma Sci.* **36** 1314
- [14] Lu X and Laroussi M 2006 *J. Appl. Phys.* **100** 063302
- [15] Walsh J L, Iza F, Janson N B, Law V J, Kong M G and Shi J 2010 *J. Phys. D: Appl. Phys.* **43** 075201
- [16] Zhong F, Zhang J, Liu D W and Kong M G 2008 *Phys. Plasmas* **15** 013504
- [17] Mericam-Bourdet N, Laroussi M, Begum A and Karakas E 2009 *J. Phys. D: Appl. Phys.* **42** 055207
- [18] Shashurin A A, Shneider M N, Dogariu A, Miles R B and Keidar M 2009 *Appl. Phys. Lett.* **94** 231504
- [19] Maletić D, Puač N, Malović G and Petrović Z Lj *unpublished*
- [20] Malović G, Puač N, Lazović S and Petrović Z Lj 2010 Mass analysis of an atmospheric pressure plasma needle discharge *Plasma Sources Sci. Technol.* **19** 034014
- [21] Lazović S, Puač N, Miletić M, Pavlica D, Jovanović M, Bugarski D, Mojsilović S, Maletić D, Malović G, Milenković P and Petrović Z Lj 2010 *New J. Phys.* **12** 083037
- [22] Stoffels E, Sakiyama Y and Graves D B 2008 *IEEE Trans. Plasma Sci.* **36/4** 1441

ⓘ Please read chapter 3 of the Rules and Principles for COST (Level A). In order to keep using e-COST, you have to declare to abide by its principles [clicking here](#). ✕



Invitations / COST Training School

Dear Mr Kosta Spasic

You are invited to the following COST Training School as trainee.

Training School Details

ID	ECOST-TRAINING_SCHOOL-TD1208-030214-038233
Title	Chemistry initiated by electrical discharges with liquids
Start Date	2014/02/03
End Date	2014/02/06
Location	Jozef Stefan Institute
Local Organiser Name	Dr Uros Cvelbar
Local Organiser email	uros.cvelbar@guest.arnes.si
Local Organiser Organisation	Jozef Stefan Institute

 Please read chapter 3 of the Rules and Principles for COST (Level A). In order to keep using e-COST, you have to declare to abide by its principles [clicking here](#). 

Invitations / COST Training School

Dear Mr Kosta Spasic

You are invited to the following COST Training School as trainee.

Training School Details

ID	ECOST-TRAINING_SCHOOL-MP1101-061013-033598
Title	Bad Honnef Summer School and Master Class
Start Date	2013/10/06
End Date	2013/10/12
Location	Physikzentrum Bad Honnef
Local Organiser Name	Mr Marc Boeke
Local Organiser email	marc.boeke@rub.de
Local Organiser Organisation	Ruhr University Bochum



27th Summer School and International Symposium on the Physics of Ionized Gases

August 26 – 29, 2014, Belgrade, Serbia

- [Home >](#)
- [About SPIG >](#)
- [Committees >](#)
- [News >](#)
- [Deadlines >](#)
- [Topics & Program >](#)
- [Invited Lectures >](#)
- [Workshops >](#)
- [Registration >](#)
- [Papers >](#)
- [Location >](#)
- [Travel Information >](#)
- [Accommodation >](#)
- [Social program >](#)
- [Sponsors >](#)
- [Links >](#)
- [Contact >](#)
- [First Announcement >](#)
- [Final Announcement >](#)
- [Conference Poster >](#)
- [SPIG 2012 Homepage >](#)
- [SPIG 2010 Homepage >](#)
- [SPIG 2008 Homepage >](#)
- [SPIG 2006 Homepage >](#)
- [Previous SPIG Lecturers >](#)

SPIG SCIENTIFIC COMMITTEE

- Z. Mijatović (Chair), Serbia
- S. Buckman, Australia
- J. Burgdörfer, Austria
- M. Danezis, Greece
- Z. Donko, Hungary
- V. Guerra, Portugal
- M. Ivković, Serbia
- D. Jovanović, Serbia
- K. Lieb, Germany
- I. Mančev, Serbia
- D. Marić, Serbia
- N. J. Mason, UK
- A. R. Milosavljević, Serbia
- K. Mima, Japan
- Z. Mišković, Canada
- B. Obradović, Serbia
- G. Poparić, Serbia
- L. C. Popović, Serbia
- Z. Rakočević, Serbia
- Y. Serruys, France
- N. Simonović, Serbia
- M. Škorić, Japan
- M. Trtica, Serbia

SPIG 2014 ORGANIZING COMMITTEE Institute of Physics Belgrade

- D. Marić (Co-chair)
- A. R. Milosavljević (Co-chair)
- S. D. Tošić (Co-Secretary)
- N. Škoro (Co-Secretary)
- Z. Lj. Petrović
- B. P. Marinković
- M. Cvejić
- J. Sivoš
- K. Spasić
- M. Ranković

SPIG ADVISORY COMMITTEE

- D. Belić
- N. Bibić
- M. S. Dimitrijević
- S. Đurović
- N. Konjević
- J. Labat
- B. P. Marinković
- M. Milosavljević
- Z. Lj. Petrović
- J. Purić
- B. Stanić

News

Jun 26 2015
[SPIG-central website started](#)

Dec 23 2014
[Papers of Invited Lectures - JPCS](#)

Sep 02 2014
[SPIG 2014 Poster prize](#)

Sep 02 2014
[Photos from SPIG 2014](#)

Deadlines

Sep 15 2014
Full papers of Invited lectures

Meetings

August 28 2014
[COST Celina WG1 Meeting](#)

Follow us!





22nd International Conference on
Gas Discharges and Their Applications

September, 2-7, 2018.
Novi Sad - Serbia

[Home](#) [General Information](#) [Committee](#) [Program](#) [Registration](#) [Call for Papers](#) [Location & Travel](#) [Contact](#)

Committee

You are here [Home](#) > [Committee](#)

Executive management committee:

Dr. J.E. Jones, Chair
Prof. G.R. Jones
Prof. J.W. Spencer
Prof. K Hidaka
Dr. A.B. Murphy
Prof. D. Hong
Dr. P. Robin-Jouan

International scientific committee:

Dr. J.-M. Bauchire, France
Dr. J.-P. Borra, France
Prof. Yann Cressault, France
Prof. M. Farzaneh, Canada
Prof. C.M. Franck, Switzerland
Prof. A. Haddad, UK
Prof. K. Hidaka, Japan
Prof. D. Hong, France
Prof. G.R. Jones, UK
Dr. J.E. Jones, UK
Dr. A.B. Murphy, Australia
Prof. Z. Lj. Petrović, Serbia
Prof. G.J. Pietsch, Germany
Prof. V. Rakov, USA
Prof. Ph. Robin-Jouan, France
Prof. A. Robledo-Martinez, Mexico
Prof. Kohki Satoh, Japan
Dr. M. Seeger, Switzerland
Prof. J.W. Spencer, UK
Dr. S. Stangherlin, Switzerland
Dr. T. Teich, Switzerland
Dr. Igor Timoshkin, UK
Prof. J. -Y. Trepanier, Canada
Prof. K.-D. Weltmann, Germany
Prof. Y. Wu, China
Dr. J. D. Yan, UK
Dr. J. L. Walsh, UK

Local organizing committee:

Prof. Zoran Lj. Petrović, Chair
Dr. Nevena Puač, Co-Chair
Dr. Saša Dujko, Co-Chair
Dr. Nikola Škoro, Secretary
Dr. Danko Bošnjaković
Kosta Spasić
Prof. Bratislav Obradović
Dr. Dragana Marić
Dr. Gordana Malović
Jelena Sivoš
Marija Puač
Dejan Maletić
Nenad Selaković
Jasmina Atić
Ilija Simonović
Vladan Simić



HOME

NEWS

PROGRAM

PHOTO GALLERY

VENUE

REGISTRATION

ABSTRACTS AND PAPERS

ACCOMMODATION

TRAVEL

COMMITTEES

HISTORY

CONTACTS

WORKSHOP

SPONSORS



MINISTRY OF EDUCATION, SCIENCE
AND TECHNOLOGICAL DEVELOPMENT



EUROPEAN PHYSICAL JOURNAL D

Committees

Local Organising Committee

- Zoran Lj. Petrović (SASA, IPB) **Chair**
- Bratislav Marinković (IPB) **Co-Chair**
- Saša Dujko (IPB) **Co-Chair**
- Sanja Tošić (IPB) *Secretary*
- Dragana Marić (IPB) *Conference Manager*
- Gordana Malović (IPB)
- Danko Bošnjaković (IPB)
- Andrej Bunjac (IPB)
- Jelena Sivoš (IPB)
- Marija Puač (IPB)
- Ilija Simonović (IPB)
- Vladan Simić (IPB)
- Nenad Selaković (IPB)
- Dejan Maletić (IPB)
- Kosta Spasić (IPB)
- Olivera Jovanović (IPB)
- Anđelija Petrović (IPB)
- Goran Poparić (FP)
- Biljana Grozdanić (SASA)
- Aleksandra Hreljac (SASA)

Positron International Advisory Committee

- David Cassidy (University College London), **Chair**
- Gustavo Garcia (Consejo Superior de Investigaciones Científicas)
- Michael Bromley (University of Queensland)
- Marcio Varella (Universidade de São Paulo)
- Masanori Tachikawa (Yokohama City University)
- Roberto Brusa (Università di Trento)
- James Danielson (University of California, San Diego)
- Laszlo Liskay (University of Paris, Saclay)

Electron International Advisory Committee



Република Србија

Министарство просвете, науке и технолошког развоја

Годишњи извештај о раду на пројекту у 2019. години

<i>ПРОГРАМ</i>	<i>Програм интегралних и интердисциплинарних истраживања</i>
----------------	--

<i>ОБЛАСТ</i>	<i>Биомедицина</i>
---------------	--------------------

<i>Назив пројекта</i>	<i>Примене нискотемпературних плазми у биомедицини, заштити човекове околине и нанотехнологијама</i>
-----------------------	--

<i>Евиденциони број</i>	<i>41011</i>
-------------------------	--------------

Годишњи извештај о раду на пројекту у 2019. години

Име: Невена
Презиме: Пуач
Број телефона: 3713-144
E-mail адреса: nevena@ipb.ac.rs
Радна организација: 200024-Универзитет у Београду, Институт за физику
Град: Belgrade
Број поште: 11080
Општи подаци
Број пројекта 41011
Назив пројекта Примене нискотемпературних плазми у биомедицини, заштити човекове околине и нанотехнологијама
Програм Програм интегралних и интердисциплинарних истраживања
Област Биомедицина
Циљ пројекта
Циљ истраживања у претходном периоду(2019. години) Проверавана је репродуцибилност резултата масене спектрометрије у пражњењима и рађена су мерења техником масене спектрометрије прага за јонизацију како би се измерило и потврдило присуство побуђених атомских и молекулских врста кисеоника. На свим снагама је примећен значајан пад активних врста кисеониковог атома док је пад побуђених врста кисеониковог молекула примећен само на нижим снагама. У сарадњи са Институтом за биолошка истраживања „Синиша Станковић“ је испитиван утицај параметара као што је радни притисак и време третмана на ензимски одговор код третираног семена. У капацитивно спрегнутом план-паралелном систему је оптичком емисионом спектроскопијом снимана временска еволуција интензитета линија атомског кисеоника и молекулског азота током третмана површина различитих материјала са циљем испитивања механизма интеракције плазме са површином узорка. Рађени су третмани памучних тканина различитог типа ткања. Овај материјал је третиран у азотној и кисеоничној плазми у циљу побољшања квалитета бојења боја добијених од отпадних биљака. У питању су коровске биљке које се свакодневно уклањају у градовима и тиме настаје огромна количина отпадног органског материјала. Истраживање је рађено у сарадњи са Природно-техничким факултетом из Љубљане. У сарадњи са колегама из ИНЕП-а настављена је сарадња на изучавању утицаја медијума RPMI 1640 који се користи за манипулацију са ћелијама третираног плазмом на ћелијске линије. Показани је да је главни параметар који може да се корелише са утицајем третираног медијума на ћелија снага предата делу пражњења које се налази у додиру са површином медијума. Утврђено је да се третманом нискотемпературне атмосферске плазме повећава квашљивост и површинска енергија дентина чиме се постиже боља пенетрација и дистрибуција апликованог адхезива у поређењу са осталим стандардним клиничким протоколима. Атмосферски плазма извори су коришћени за производњу плазма активираних воде (ПАВ). ПАВ је коришћен за имбибицију семена и даје сличне резултате у повећању процента клијавости, деконтаминацији семена и биљака и њиховом бржем расту. Урађено испитивање утицаја деконтаминираних воде на клијавост семена кукуруза и ротквица. У односу на контролне узорке добијено је повећање процента клијавости семена након третмана загађене воде што је потврдило претпоставку да се нискотемпературска плазма може користити за третмане пречишћавања воде загађене пестицидима за њену даљу употребу у пољопривреди. Урађена анализа морфолошких и физиолошких промена у биљним ћелијама и ткивима третираних атмосферском плазмом као и In vivo детекција и квантификација реактивних форми кисеоника употребом флуоресцентних боја. Експерименти су рађени након тремана калуса различитих моделних и ендемских биљака. План паралелни систем атмосферске плазме је коришћен за третман вештачких семена. Урађена је провера клијавости третираних семена и степен преживљавања. Показало се да семена третирана плазмом имају већи процена преживљавања и већу могућност развоја у одраслу биљку. Испитиван је утицај третмана атмосферске плазме на окоштавање ткива. Урађена је декалцификација и калуљење узорака добијених из жртвованих кунића. Након тога је урађена хистоморфометријска анализа. Након завршене хомогенизације и лизе узорака одрађена је анализа протеинског састава ткивног лизата. Настављен је рад на пробоју и пражњењима у парама алкохола као и на компилирању сетова пресека за јоне и брзе неутрале у воденој пари. Глобалним моделом су урађени прорачуни који одговарају геометрији диелектричног баријерног пражњења које се користи у применама у третману медијума и воде. Претходно добијени експериментални резултати пробоја у радиофреквентним пољима су коришћени у Monte Carlo анализи коефицијената секундарне емисије и рефлексije електрона, као и утицаја јона и фотона на пробој у аргону. На примеру кисеоника, проучаван је утицај захвата електрона на пробој. У оквиру ове тематике одбрађена је докторска дисертација током 2019. године. Проучавани су нелокални ефекти у пропагацији стримера на интерфејсу плазма-течност, а тестиран је и домен применљивости класичног флуидног модела и апроксимације локалног поља. Рађено је испитивање транспорта лаких наелектрисаних честица у неполарним течностима.
Процент испуњења циља 100
Навести шта није остварено и зашто? Највећи проблеми у реализацији, као у току претходних година, је динамика исплате директних материјалних трошкова. Први прилив средстава је након што је завршен први квартал а последња уплата је у другој половини децембра што не омогућава континуитет у набавци репроматеријала (поготово када су у питању реагенси за експерименте у биологији и медицини). Пошто је у овом тренутку приоритет објављивање радова у часописим са отвореним приступом (Open Access Journals) било би пожељно да се оствари посебан фонд који ће моћи да се користи за овакве намене.
Активности на пројекту у години за коју се подноси извештај
Планиране активности у деветој години истраживања (1. 1. 2019 - 31. 12. 2019.) (садржај табеле дат на крају)
Ангажовани истраживачи
Истраживачи ангажовани у години за коју се подноси извештај (садржај табеле дат на крају)
Докторанти ангажовани на пројекту (садржај табеле дат на крају)

Р.Б.	ЈМБГ	Име	С	Презиме	Титула	Звање	Датум стицања звања (дд/мм/гггг)	Шифра НИО	Тренутни статус	Тренутни БИМ	Категорија (стање)	Е - mail истраживача	Напомена
40		Коста		Спасић		9-Истраживач сарадник	09/07/2019	200024	Да	11	A4	kosta.spasic@ipb.ac.rs	



Република Србија

Министарство просвете, науке и технолошког развоја

Годишњи извештај о раду на пројекту у 2019. години

<i>ПРОГРАМ</i>	<i>ОСНОВНА ИСТРАЖИВАЊА</i>
----------------	----------------------------

<i>ОБЛАСТ</i>	<i>Физика</i>
---------------	---------------

<i>Назив пројекта</i>	<i>Фундаментални процеси и примене транспорта честица у неравнотежним плазмама, траповима и наноструктурама</i>
-----------------------	---

<i>Евиденциони број</i>	<i>171037</i>
-------------------------	---------------

Годишњи извештај о раду на пројекту у 2019. години

Име: Зоран
Презиме: Петровић
Број телефона: 62802-6994
E-mail адреса: zoran@ipb.ac.rs
Радна организација: 200024-Универзитет у Београду, Институт за физику
Град: Belgrade
Број поште: 11080
Страна 1 - Општи подаци
Програм ОСНОВНА ИСТРАЖИВАЊА
Област Физика
Број пројекта 171037
Назив Пројекта Фундаментални процеси и примене транспорта честица у неравнотежним плазмама, траповима и наноструктурама
Тип пројекта Б-Експериментални
Страна 2 - Опис истраживања
Циљеви истраживања (према достављеном плану истраживања) остварени у 2019. години имајући у виду значај, квалитет и ниво остварених резултата. Рад у току 2019. године дат је по темама истраживања Транспорт наелектрисаних честица (руководилац С. Дујко) У току 2019. године је настављен рад на проучавању ефеката анизотропије расејања у аргону на транспортне особине електрона у временски константним и временски променљивим електричним пољима. На основу нумеричких мулти терм решења Болцманове једначине и Монте Карло симулација, проучаван је ефекат температуре гаса на негативну диференцијалну проводност у молекуларном азоту. Предложен је једнаоставан аналитички сет пресека са циљем разумевања улоге супереластичних судара на НДП. Модификујући Фрост-Фелпсов колизиони оператор за нееластичне сударе, проучаван је ефекат узмака неутралног молекула након расејања на ефекат НДП. Транспорт електрона и развој електронских лавина су разматрани у условима оксидујуће и редукујуће атмосфере примордијалне планете Земље. Проучавана је пропагација позитивних и негативних стримера у флуидним и РИС/МС моделима у раној атмосфери Земље. У сарадњи са групом из Будимпеште, разматрана је еквилибрација роја електрона у аргону на основу експерименталних резултата добијених у сканирајућој дрефтној цеви и Монте Карло симулација. У оквиру транспортне теорије наелектрисаних честица у течностима, израчунати су транспортни коефицијенти трећег реда у течном ксенону и упоређени са онима који су добијени у гасној фази. Развијен је модел за пропагацију стримера у неполарним течностима у реалним геометријама, који подразумевају нехомогене расподеле електричног поља и имплементацију ликова у систему електрода. Симулације детектора честица високих енергија (руководилац Данко Бошњаковић). Користећи нумеричка мулти терм решења Болцманове једначине као и Монте Карло симулације, анализиран је транспорт електрона у гасним смешама неона и угљен диоксида које се користе као радни гасови у ТРС коморама. Посебно је разматран утицај гасних нечистоћа (попут азота и водене паре) као и варијације температуре гаса и процентуалног садржаја CO ₂ у смеси Ne-CO ₂ на транспорт електрона. Такође је проучаван транспорт електрона у укрштеним електричним и магнетским пољима где је акценат стављен на утицај угла између вектора поља на транспортне параметре електрона. Транспорт позитрона у гасовима и течностима (руководилац Саша Дујко). Пресеци за ротациону екситацију позитрона у сударима са молекуларним водоником су израчунати применом Герцоу-Штајн и Далгарно-Мофет теорија. Ови пресеци су имплементирани у већ развијени сет пресека за расејање позитрона у водонику у нашем Центру и на основу овог унапређеног сета пресека су израчунати транспортни коефицијенти. Проучавана је осетљивост транспортних коефицијената и термализација позитрона на ротациону екситацију. Лонгитудинални транспортни коефицијент трећег реда показује највећу осетљивост на ротациону екситацију. Присуство ротационе екситације смањује средњу енергију, лонгитудиналну и трансверзалну компоненту дифузионог тензора и лонгитудиналну компоненту транспортног тензора трећег реда, али повећава како балк тако и флакс брзину дрефта, у лимиту нижих вредности редукованог електричног поља. Разлике у пресецима за ротациону екситацију нису изражене у профилима транспортних коефицијената. Дијагностика и примене радио-фреквентних плазми на ниском притиску (руководилац Г.Маловић): Настављено је са дијагностиком асиметричног реактора велике запремине. Проверавана је репродукцибилност резултата масене спектрометрије у пражњењима у смеси гасова која садржи 99 %O ₂ и 1 % Ar. У истом реактору су рађена и мерења техником масене спектрометрије прага за јонизацију како би се измерила концентрација побуђених атомских и молекулских врста кисеоника. Због поправки на вакуумском систему, поново су рађена и мерења електричних особина којима је могуће утврдити ефикасност предаје снаге плазми као и добити детаљни увид струјно-напонске особине система. У мањем, планпаралелном, реактору је поред третмана текстила такође рађено мерење електричних особина али су рађена и мерења оптичке спектрометрије у временски разложеном режиму (током третмана). Дијагностика и примене плазми на атмосферском притиску (руководилац: Н. Пуач) -Конструкција и дијагностика: Рађена је масена спектроскопија диелектричног баријерног пражњења (плазма млаза) које ради на атмосферском притиску. Мерени су утицаји влажности на формирање пражњења а самим тим и на масене спектре неутрала и позитивних и негативних јона. Колега Малетић је у 2019. години радио на постављању експеримента који ће користити DYE ласер за дијагностику плазми на атмосферском притиску. Паралелно са овим експериментом постављен је систем који користи наносекундни ласер Nd-YAG на 532 nm за производњу наночестица ласерском аблацијом чврстих узорака у течностима и успешно су извршена почетна мерења. Урађено је ICCD снимање и електрична карактеризација двоелектродног плазма млаза са малим унутрашњим пречником цевчице (капиларе). Резултати за брзине простирања јонизационог фронта добијени из ових мерења су упоређени са резултатима добијеним у оквиру посете Институту за физику у Загребу. У Загребу су за исти плазма млаз урађена спектроскопска мерења ласерски индукованог пробоја са предјонизацијом плазма млаза. -Биомедицинске примене: Реализована је сарадња са два института: Институт за примену нуклеарне енергије и Институт за биолошка истраживања Синиша Станковић. У оквиру тих сарадњи конструисан је и прилагођен потребама третмана извор неравнотежне плазме на атмосферском притиску помоћу којег је третирана вода и медијум за узгајање ћелија RPM1 1640. Третирана вода коришћена је даље за третман рана на кожи мишева и праћено је зарастање рана услед утицаја реактивних кисеоничних и азотних врста из третиране воде насталих под утицајем плазме. Третирани медијум коришћен је за третман ћелија и праћење цитотоксичности на ћелијама. Коришћене су различите концентрације кисеоничних и азотних врста у течностима приликом третмана рана и ћелија. Ово је постигнуто варирањем снаге предате плазми. -Плазма у пољопривреди: У оквиру ове истраживачке теме урађена је мастер теза Andrea

Callegari-ja. Испитиван је утицај воде третиране плазмом на семена ротквице која су пореклом из Србије и Италије. Узорци воде су третиран са два различита плазма извора: (1) диелектрично баријерно пражњење-плазма млаз; (2) референтни COST РФ плазма извор. Урађена је електрична карактеризација оба извора. Вода третирана плазмом је коришћена за исклијавање семена ротквице код којих је након тога испитивана активност ензима. Деструкција органофосфата у течности (руководилац Никола Шкоро) Истраживање је било је фокусирано на третмане коришћењем плазма млаза са зашиљеном електродом на третмане чисте и загађене воде са циљем испитивања хемијских промена у течним узорцима након третмана и утицаја третиранних течних узорака на семена биљака које се користе у комерцијалној пољопривредној производњи. Развијена је и успостављена нова дијагностичка метода за мерење концентрација активних кисеоничних и азотних врста у течним узорцима. Поред тога је урађена и дијагностика течних узорака мерењем физичко-хемијских особина течности. Добијени су сетови података који омогућавају проучавање утицаја течног узорка на особине нискотемпературског пражњења. Резултати су добијени при третманима воде загађене пестицидима, дестиловане, и воде са чесме. Заједно са колегама са Технолошко-металуршког факултета развијена је инструментална метода за одређивање производа деградације органофосфатног пестицида малатиона на течном хроматографу спрегнутом са масеним анализатором. Друга сарадња обављена је у оквиру интердисциплинарног истраживања на Фармацеутском факултету за чије потребе су третиран узорци воде са чесме који су даље коришћени у експерименту у исхрани пацова. Физика елементарних честица (руководилац: Вељко Дмитрашиновић) Наставили смо рад, са Джемсом Личом и урадили смо хиперсферну анализу нумеричких резултата израчунавања потенцијала три тешка кварка на 4-димензионалној Еуклидовој решети методом Lattice QCD. Резултати овог истраживања су потврдили резултате Кома (2017.) и тиме само појачали раније стечени утисак неочекиваности, јер нико није предвидео овакав резултат. Ми смо дали геометријско тумачење овог резултата, у смислу „деформације“ У-струне, а користећи Ојлерову праву. Али, динамичко порекло овог ефекта, који мора имати важне последице у системима 3 или више кваркова, остаје непознато. Квантно-механички проблем три тела (руководилац: Вељко Дмитрашиновић) Наставили смо и рад на проблему три честице у квантној механици, а нарочито на питању конфајнмента три кварка. Већ смо раније конструисали, све тро-димензионалне симетризоване хиперсферне хармонике за тро-честични квантно-механички проблем, а сада смо применили исте и на проблем три (ултрарелативистичка) кварка са нултом масом у потенцијалу хармонијског осцилатора. В.Д. је преиспитао ранију семи-класичну квантизацију ефекта Ефимова и нашао извесне недостатке, који су га навели на систематско истраживање свих периодичних орбита три тела у класичној механици Ефимовљевог ефекта са интересантним резултатима. Физика и статистика пробоја на ниском притиску (руководилац: Драгана Марић.) - Пробој и неравнотежна пражњења у парама течности: Настављен је рад на пробоју и пражњењима у парама алкохола. Комплетан је сет референтних података за метанол, етанол, пропанол и бутанол. Урађено је детаљно поређење особина проучаваних алкохола и анализирани трендови који прате постепено повећање комплексности молекула. У току је израда докторске дисертације базиране на резултатима. - Развој базе података за пробој и пражњења у атмосфери која садржи водену пару: Настављен је рад на компилирању сетова пресека за јоне и брзе неутрале у воденој пари, у току је припрема радова за H₃O⁺ и OH⁻ јоне. - Пробој у радиофреквентним пољима: У сарадњи са Проф. Антонијем Ђорђевићем, САНУ, настављен је рад на развоју експеримента за проучавање пробоја у радиофреквентним пољима. Након поправке опреме, урађена је калибрација капацитивних разделника напона, који се користе као напонске сонде и провера резултата мерења у аргону. Започета су мерења пробоја у компримованом ваздуху. Траповање позитрона и електрона (руководилац Зоран Љ Петровић) Основна тема којом смо почели да се бавимо била је дифузионо загревање позитрона у неону при термализацији, услед Рамзауер Таунзендовог минимума у пресеку, за расејање у неону. У 2019. смо наставили да се бавимо темом термализације позитрона у траповима на ниским температурама (течни азот). Транспорт и моделовање кинетике јона у смешама са радикалима (руководилац: Зоран Распоповић) Завршени су прорачуни транспорт јона аргона у смеси аргона и тетрафлуорометана. Започета су и истраживања интеракција јона и атома са затвореним електонским љускама. Написан је код који прорачунава два пресека, транспортни моментум трансфер пресек и асоцијативни пресек, који у прорачунима треба да дају прихватљива одступања од експерименталних резултата. Пресеци за расејање електрона у гасовима и транспортни коефицијенти (руководилац Зоран Љ Петровић) Приказана је прелиминарна презентација тетрафлуоропропена на међународној конференцији. Финализован је рад на диметил етру и спремљен је материјал за писање рада. Моделовање пробоја у једносмерним и радио-фреквентним пољима (руководилац: Зоран Љ. Петровић) Настављен је рад на симулацијама пробоја у РФ пољима у кисеонику и тиме је проучаван утицај захвата електрона, као и утицај енергијских губитака, у процесима вибрационе ексцитације, на пробој. Програм ће се проширити на симулације пробоја у једносмерним пољима и у комбинованим пољима. Примена Глобалног модела за изучавање хемије плазме (руководилац Саша Гоцић) Током 2019. изучавали смо кинетику плазма хемијских процеса у атмосферском пражњењу у смеси аргона или хелијума са атмосферским гасовима и воденом паром. Пре свега је разматран утицај разних количина водене паре у смеси на кинетику. Развијена је метода да се одреде прецизно услови за симулацију, који би одговарали реалним условима у атмосферским плазма цетовима. Тако је извршено поређење масеног спектра, добијеног мерењем и симулацијама, и добијено је одлично слагање за оне честице за које се може потврдити да су настале у плазми.

Процент испуњења циља 100

Навести шта није остварено и зашто? Велико кашњење уплата у првој половини године и неизвесност када и колике уплате ћемо добити у потпуности спречава могућност планирања рада. Свака група која гради експерименте има краткорочне планове који су остварени у нашем случају и дугорочне планове који зависе од способности да се набави скупља опрема и материјал за изградњу. Ми веома касним домену изградње и унапређења апаратура од чега ће зависити наш рад и ниво успеха у будућности а то кашњење се директно не види на тренутним резултатима. Такође, то кашњење се манифестује у пропуштеним шансама које је реализовао неко други и пропуштеним могућностима за будуће пројекте са екстерним финансирањем. На пример, због недостатка 20 000 евра за комплетирање апаратуре, већ је пропуштена прилика да реализујемо наш дугорочни план, да будемо први који ће измерити транспортне коефицијенте и на основу тога одредити пресеке за неку од органских пара. Уз редовне и адекватне уплате имали бисмо већи напредак у конструкцији: -коморе за плазма нагризање и кинетику плазми за третман органских диелектрика -коморе за мерење транспортних коефицијената у режиму Pulsed Townsend (што је умањило нашу могућност добијања апликативних пројеката) -уређаја за производњу наноструктура и њихову контролу сноповима неутрала -мулти цет система на атмосферском притиску -реализације обновљеног Милеровог експеримента и детекције шећерне болести из даха пацијента. Напредак у домену добијања сетова пресека и микро пражњења је успорен због немогућности да се приме нови сарадници (што је опет било битно за међународну сарадњу и пројекте). Напредак у финализацији докторских дисертација је знатно умањен немогућношћу да се плате школарине код неких факултета. Уплате највећег дела ДМТ2 у другој половини децембра, са условљавањем да се потроше до краја године а да се при том не зна до задњег дана колико новца ће бити уплаћено, спречава како планирање рада тако и реализацију жељених набавки. То су све били елементи на које нисмо могли да утичемо.

Страна 3 - Ангажовани истраживачи

Истраживачи ангажовани у години за коју се подноси извештај (садржај табеле дат на крају)

Докторанти ангажовани на пројекту (садржај табеле дат на крају)

Страна 4 - Прилози уз Извештај

Да ли сте попунили апликацију ЗАВРШНИ ИЗВЕШТАЈ? Да

Да ли су истраживачи попунили резултате за 2019. у РИС бази (повезати оне резултате који су настали са овог пројекта? Приложите .xls фајл списак резултата везан за пројекат, који руководиоца може да преузме са свог налога у РИС бази код прегледа својих резултата. Да

Да ли сте доставили Изјаву о тачности података? Да

Страна 5 - Прилози уз извештај

Овера извештаја (садржај табеле дат на крају)

Истраживачи ангажовани у години за коју се подноси извештај

Р.Б.	ЈМБГ	Име	С	Презиме	Титула	Звање	ДАТУМ стицања звања (дд/мм/гггг)	Шифра НИО	Тренутни статус	Тренутни БИМ	Категорија (стање)	Е - mail истраживача	Напомена
		Зоран		Петровић	4-Dr	12-Научни саветник	29/05/1995	200024	Да	10	A1	zorana@ipb.ac.rs	od 20.12.2019 u penziji
		Гордана		Маловић	4-Dr	12-Научни саветник	10/10/2007	200024	Да	6	A1	malovic@ipb.ac.rs	
3		Драгана		Марић	4-Dr	12-Научни саветник	28/01/2016	200024	Да	6	A2	draganam@ipb.ac.rs	
4		Невена		Пуач	4-Dr	12-Научни саветник	26/10/2016	200024	Да	2	A1	nevena@ipb.ac.rs	
		Вељко		Дмитрашиновић	4-Dr	12-Научни саветник	26/06/2001	200024	Да	11	A1	dmitrasin@ipb.ac.rs	
		Владимир		Стојановић	4-Dr	11-Виши научни сарадник	01/01/2000	200024	Не	0	A2	promeni@ipb.ac.rs	
		Марија		Радмиловић-Рађеновић	4-Dr	12-Научни саветник	01/01/2000	200024	Не	0	A1	promeni@ipb.ac.rs	
		Бранислав		Рађеновић	4-Dr	12-Научни саветник	01/01/2000	200024	Не	0	A1	promeni@ipb.ac.rs	
		Жељка		Никитовић	4-Dr	12-Научни саветник	01/01/2000	200024	Не	0	A2	promeni@ipb.ac.rs	
10		Зоран		Распоповић	4-Dr	11-Виши научни сарадник	25/09/2016	200024	Да	1	A3	zr@ipb.ac.rs	
11		Никола		Шкоро	4-Dr	11-Виши научни сарадник	25/04/2018	200024	Да	10	A4	nskoro@ipb.ac.rs	
12		Саша		Лазовић	4-Dr	10-Научни сарадник	01/01/2000	200024	Не	0	A2	promeni@ipb.ac.rs	
13		Марија		Пуач	4-Dr	9-Истраживач сарадник	20/12/2019	200024	Да	10	A4	smarija@ipb.ac.rs	Koleginica je izabrana u zvanje naucnog saradnika 20.12.2019
14		Милован		Шуваков	4-Dr	11-Виши научни сарадник	01/12/2010	200024	Да	0	A1	suki@ipb.ac.rs	
15		Саша		Дујко	4-Dr	12-Научни саветник	23/12/2015	200024	Да	10	A1	sasa.dujko@ipb.ac.rs	
16		Срђан		Марјановић	4-Dr	9-Истраживач сарадник	01/01/2000	200024	Не	0	A4	promeni@ipb.ac.rs	
17		Ана		Банковић-Cassidy	4-Dr	10-Научни сарадник	01/01/2000	200024	Да	0	A1	promeni@ipb.ac.rs	
		Дејан		Малетић	4-Dr	9-Истраживач сарадник	17/05/2015	200024	Да	1	A4	dejan.maletic@ipb.ac.rs	
19		Оливера		Шашић	4-Dr	5-Редовни професор	16/03/2016	200128	Да	7	A2	osasic@ipb.ac.rs	
20		Саша		Гоцић	4-Dr	4-Ванредни професор	23/06/2013	200124	Да	8	A2	sgocic@pmf.ni.ac.rs	
21		Јасмина		Јовановић	4-Dr	5-Редовни професор	12/06/2013	200105	Да	7	A3	jjovanovic@ipb.ac.rs	
22		Александар		Бојаров	4-Dr	9-Истраживач сарадник	01/01/2000	200024	Не	0	A4	promeni@ipb.ac.rs	
23		Илија		Стефановић	4-Dr	12-Научни	01/10/2012	200175	Да	0	A1	ilija.stefanovic@ipb.ac.rs	

Р.Б.	ЈМБГ	Име	С	Презиме	Титула	Звање	ДАТУМ стицања звања (дд/мм/гггг)	Шифра НИО	Тренутни статус	Тренутни БИМ	Категорија (стање)	Е - mail истраживача	Напомена
						саветник							
26		Јово		Врањеш	4-Dr	20-Странац	01/01/2000	200024	Да	0	A1	promeni@ipb.ac.rs	
27		Рон		Вајт	4-Dr	20-Странац	01/01/2000	200024	Да	0	A1	promeni@ipb.ac.rs	
28		Кинга		Кутаси	4-Dr	20-Странац	01/01/2000	200024	Да	0	A1	promeni@ipb.ac.rs	
27		Коста		Спасић	2-Ма	9-Истраживач сарадник	28/05/2013	200024	Да	1	A4	kosta.spasic@ipb.ac.rs	
28		Јелена		Марјановић	2-Ма	9-Истраживач сарадник	18/07/2017	200024	Да	11	A4	jelena.sivos@ipb.ac.rs	
29		Данко		Бошњаковић	4-Dr	10-Научни сарадник	27/09/2017	200024	Да	12	A4	dbosnjak@ipb.ac.rs	
30		Илија		Симоновић	2-Ма	9-Истраживач сарадник	27/12/2016	200024	Да	12	A4	ilija.simonovic@ipb.ac.rs	
31		Владан		Симић	2-Ма	8-Истраживач приправник	01/01/2000	200024	Да	12	A4	vladan.simic@ipb.ac.rs	
32	1805989732546	Жељко		Младеновић	2-Ма	2-Асистент	01/01/2000	200124	Да	8	A4	plasmaacdc.mladenovic@pmf.ni.ac.rs	

Докторанти ангажовани на пројекту

Р.Б.	ЈМБГ	Име	Презиме	Звање	НИО запослења	НИО уписаних докторских студија	Име и Презиме ментора	Број индекса	Година уписа докторских студија	Назив докторске дисертације	Статус дисертације	Напомена
1		Марија	Пуач	9-Истраживач сарадник	200024	200103-Универзитет у Београду, Електротехнички факултет	Зоран Петровић	5048/2009	2009	Моделовање пробоја у гасовима Монте Карло техником	3-Одбрањена	
		Срђан	Марјановић	9-Истраживач сарадник	200024	200103	н	x			3-Одбрањена	
		Дејан	Малетић	9-Истраживач сарадник	200024	200162	н	x			3-Одбрањена	
		Александар	Бојаров	9-Истраживач сарадник	200024	200162	н	x			1-Пријављена	
		Коста	Спасић	9-Истраживач сарадник	200024	200162-Универзитет у Београду, Физички факултет	Зоран Пуач	8022/2018	2018	Дијагностика асиметричног и план паралелног радио-фреквентног плазма система у циљу дефинисања плазма хемијских процеса током третмана узорака органск	2-Одобрена / Прихваћена	
		Јелена	Марјановић	9-Истраживач сарадник	200024	200162-Универзитет у Београду,	Зоран Марић	8001/2018	2018	Пробој и особине	2-Одобрена / Прихваћена	

Р.Б.	ЈМБГ	Име	Презиме	Звање	НИО запослења	НИО уписаних докторских студија	Име и Презиме ментора	Број индекса	Година уписа докторских студија	Назив докторске дисертације	Статус дисертације	Напомена
						Физички факултет				неравнотежних ДС пражњења на ниском притиску у парама течности		
7		Илија	Симоновић	9-Истраживач сарадник	200024	200162-Универзитет у Београду, Физички факултет	Бранковић Дујко	2013/8008	2013	Кинетички и флуидни модел неравнотежног транспорта електрона у гасовима и течностима	1-Пријављена	
8		Владан	Симић	8-Истраживач приправник	200024	200162-Универзитет у Београду, Физички факултет	Бранковић Петровић	8008/2017	2017		1-Пријављена	
9		Желько	Младеновић	2-Асистент	200124	200162-Универзитет у Београду, Физички факултет	Бранковић Петровић	2013/8007	2013	"Глобални модел у опису хемијских процеса у нискотемпературним плазмама на атмосферском притиску	1-Пријављена	

Овера извештаја		
НИО реализатор	М.П.	Потпис
200024-Универзитет у Београду, Институт за физику		
200105-Универзитет у Београду, Машински факултет		
200128-Универзитет у Београду, Саобраћајни факултет		
200124-Универзитет у Нишу, Природно-математички факултет		
200175-Институт техничких наука САНУ		

Руководилац пројекта

ИЗВЕШТАЈ О РАДУ ЦЕНТРА ИЗУЗЕТНИХ ВРЕДНОСТИ

Назив центра	Центар за неравнотежне процесе
Година за коју се подноси извештај	2021
Број одлуке о акредитацији и када је донета	451-03-02763/2018-14 04.09.2018. године
<p>Кратак приказ рада центра за годину за коју се подноси извештај:</p> <p>Научни рад у току 2021.године дат је по темама истраживања</p> <p>Физика и статистика пробоја на ниском притиску (руководилац: Драгана Марић, Зоран Љ. Петровић, Гордана Маловић и Јелена Марјановић)</p> <p>Дијагностика и примене радио-фреквентних плазми на ниском притиску (руководилац: Г.Маловић, Н. Пуач, К. Спасић, Н. Шкоро и З.Љ. Петровић):</p> <p>Током 2021.-е године су рађена актинометријска мерења у асиметричном реактору велике запремине са циљем одређивања апсолутне концентрације атомског кисеоника и степена дисоцијације молекулског кисеоника. Током ових експеримената је у комори била постављена додатна уземљена електрода знатно мањег полупречника, чиме је ефективно смањена запремина реактора. Смеша радних гасова је била сачињена од 99% кисеоника (O₂) и 1% аргона (Ar) док су номиналне снаге пражњења биле између 100 W и 700 W. За прорачун је коришћен однос линија кисеоника на 844,6 nm и линије аргона на 811,5 nm. Снимања су рађена кроз бочни и фронтални прозор коморе. Због разлике у запремини плазме која је овим снимањима обухваћена, нешто већи степен дисоцијације је добијен из спектра који су снимљени са бочне стране коморе, али разлике нису велике и он се, за обе позиције снимања, креће између 2 % и 6 %. Апсолутне концентрације O атома се, зависно од притиска и номиналне снаге, крећу између 0,5 и $2 \cdot 10^{21} \text{m}^{-3}$ и такође су врло сличне за обе позиције.</p> <p>Деривативним сондама испитиване су електричне особине план паралелног система за два различита растојања између напајане и уземљене електроде током пражњења у азоту и аргону. Примећено је да временска зависност напонског сигнала изгледа као готово правилна синусоида док је временска зависност струјног сигнала изразито неправилна са двоструким минимум и максимум у оквиру једног периода побудног сигнала. Прегледом фреквентног састава сигнала је установљено да до ових изобличења долази због пораста другог хармоника струје.</p>	

1. Пројекти

1.1. Међународни пројекти

1. Рад са научним подмлатком

1. Менторство одбрањених докторских дисертација (име и презиме докторанта, ужа научна област, наслов дисертације и датум одбране):

1.

2. Курсеви и предавања за докторанте:

•

2. Учешће на научним скуповима

2.1. Међународни скупови

2.2. Домаћи скупови

1.

3. Предавања по позиву на научним скуповима

3.1. Међународни скупови

1.

3.2. Домаћи скупови

1.

4. Квантификација научноистраживачких публикација истраживача и сарадника Центра

4.1. Остварени резултати категорије 10 (аутор(и), наслов, година издавања, издавач, број страна):

1.

4.2. Остварени резултати категорије 20 (аутор(и), наслов рада, часопис, година издавања, волумен (број):странице од-до):

4.3. Остварени резултати категорије 90 (аутор(и), назив, датум признавања, институција, место):

1.

6. План рада за наредну годину

6.1. Пројекти

6.1.1. Планирани међународни пројекти
1.
6.1.2. Планирани домаћи пројекти
1.

6.2. Рад са научним подмлатком

1.

6.3. Учесће на научним скуповима

6.3.1. Међународни скупови
6.3.2. Домаћи скупови
1.

6.4. Одржавање и побољшање инфраструктуре за научноистраживачки рад

6.5. План утрошка средстава за реализацију и суфинансирање научноистраживачког рада за наредну годину

--

7. Прилози:

1.

Датум и место:

23.02.2022.

Руководилац центра изузетних вредности

Др Зоран Петровић

Директор Института за физику

Др Александар Богојевић

UNIVERZITET U BEOGRADU
FIZIČKI FAKULTET

Kosta Z. Spasić

DIJAGNOSTIKA ASIMETRIČNOG I PLAN
PARALELNOG RADIO-FREKVENTNOG
PLAZMA SISTEMA U CILJU DEFINISANJA
PLAZMA HEMIJSKIH PROCESA TOKOM
TRETMANA UZORAKA ORGANSKOG I
NEORGANSKOG POREKLA

doktorska disertacija

BEOGRAD, 2022

UNIVERSITY OF BELGRADE
FACULTY OF PHYSICS

Kosta Z Spasić

DIAGNOSTICS OF ASSYMETRICAL AND
PLAN PARALLEL RADIOFREQUENCY
PLASMA SYSTEMS WITH A GOAL OF
DEFINING PLASMA CHEMICAL PROCESSES
DURING TREATMENTS OF BOTH ORGANIC
AND INORGANIC SAMPLES

Doctoral Dissertation

BELGRADE, 2022

Mentor:

dr Nevena Puač, naučni savetnik, Univerzitet u Beogradu, Institut za fiziku

Komentor:

Dr Nikola Škoro, viši naučni saradnik, Univerzitet u Beogradu, Institut za fiziku

Članovi komisije:

dr Nikola Škoro, viši naučni saradnik, Univerzitet u Beogradu, Institut za fiziku

dr Gordana Malović, naučni savetnik, Univerzitet u Beogradu, Institut za fiziku

dr Srđan Bukvić, redovni profesor, Univerzitet u Beogradu, Fizički fakultet

dr Bratislav Obradović, redovni profesor, Univerzitet u Beogradu, Fizički fakultet

dr Goran Poparić, redovni profesor, Univerzitet u Beogradu, Fizički fakultet

Datum odbrane: 2022

Doktorska disertacija pod nazivom „Dijagnostika asimetričnog i plan paralelnog radio-frekventnog plazma sistema u cilju definisanja plazma hemijskih procesa tokom tretmana uzoraka organskog i neorganskog porekla“ urađena je pod mentorstvom dr Nevene Puač u Laboratoriji za neravnotežne procese i primenu plazmi (starije ime: Laboratorija za gasnu elektroniku) Instituta za fiziku u Beogradu. Deo rezultata, vezan za mikrotalasna pražnjenja, je napravljen u Laboratoriji za tehnologije površina, instituta Jožef Štefan iz Ljubljane, pod rukovodstvom dr Mirana Mozetiča. Karakterizacijom površina tekstilnih uzoraka, koja je rađena na Odseku za tekstile, grafiku i dizajn Prirodno-tehničkog fakulteta u Ljubljani, rukovodila je dr Marija Gorjanc. Analizom bioloških uzoraka rukovodila je dr Suzana Živković iz Odeljenja za fiziologiju biljaka Instituta Siniša Stanković iz Beograda.

Svoju zahvalnost dugujem pre svih akademiku dr Zoranu Petroviću koji me je zainteresovao i uveo u svet električnih pražnjenja. Zahvalan sam mu na pruženoj prilici da radim u laboratoriji kojom je rukovodio, na pomoći pri odabiru teme istraživanja, na mnogobrojnim seminarima i konsultacijama tokom kojih je podelio deo svog velikog iskustva ali i na nezamenljivim savetima tokom tumačenja rezultata.

Najveću zahvalnost dugujem svom mentoru dr Neveni Puač na vođenju i usmeravanju istraživanja, na prenetom znanju iz fizike plazme, na osmišljavanju i izradi eksperimenata, na konkretnim savetima bez kojih mnoga merenja ne bih priveo kraju kao i na svim onim satima koje je provela sa mnom u laboratoriji rešavajući probleme koji su mi se u tim trenucima činili nepremostivi. Takođe sam joj zahvalan na strpljenju i instrukcijama koje su bile važne za oblikovanje teksta ove disertacije.

Zahvalio bih se i svom komentoru dr Nikoli Škori čija je pomoć u pisanju disertacije i obradi rezultata bila nezamenljiva. Bez njegove temeljnosti, upornosti i iskustva, pogotovo iz oblasti optičke emisije spektroskopije i aktinometrije, prikupljanje i analiza podataka bi bili značajno veća prepreka.

Svoje prve praktične korake u laboratoriji sam napravio uz veliku pomoć dr Saše Lazovića na čemu sam mu vrlo zahvalan.

Veliku zahvalnost dugujem i dr Gordani Malović pre svega na podeljenom iskustvu i savetima ali i na, ponekad vrlo specifičnoj, motivaciji i ohrabrivanju u trenucima krize kojih je bilo mnogo.

Zahvalio bih se kolegicama sa Instituta za biološka istraživanja dr Suzani Živković i dr Milici Milutinović na saradnji u oblasti primene plazmi tokom tretmana bioloških uzoraka. Zahvalan sam još i kolegama sa instituta Jožef Štefan dr Miranu Mozetiču i dr Gregoru Primcu na saradnji i pruženoj pomoći u oblasti mikrotalasnih pražnjenja i merenja katalitičkom sondom. Posebnu zahvalnost dugujem dr Mariji Gorjanc sa Prirodno-tehničkog fakulteta u Ljubljani bez čije energije, znanja i pomoći tokom tretmana tekstilnih uzoraka bi ova disertacija imala mnogo drugačiji oblik.

Laboratorijskim tehničarima Instituta za fiziku, Vladimiru Saviću i Vladimiru Dragojloviću, sam zahvalan na idejama i tehničkoj pomoći kojom su omogućili bezbedan i kontinualan rad laboratorijske opreme.

Zahvalio bih se kolegama iz kancelarije, dr Dejanu Maletiću i dr Nenadu Selakoviću, na savetima i podršci, Anđeliji Petrović i Oliveri Jovanović kao i svim članovima Laboratorije za neravnotežne procese i primenu plazme Instituta za fiziku na tome što su doprineli da izrada disertacije bude mnogo prijatnije iskustvo.

Na kraju bih se zahvalio prijateljima i porodici, pre svih majci i bratu, na velikom strpljenju i nesebičnoj podršci tokom celog perioda školovanja.

DIJAGNOSTIKA ASIMETRIČNOG I PLAN PARALELNOG RADIO-FREKVENTNOG PLAZMA SISTEMA U CILJU DEFINISANJA PLAZMA HEMIJSKIH PROCESA TOKOM TRETMANA UZORAKA ORGANSKOG I NEORGANSKOG POREKLA

Rezime:

Plazma na niskom pritisku se već duži niz godina primenjuje u industrijama poput automobilske, elektronske ili tekstilne. Zbog načina na koji plazma interaguje sa površinama, može se koristiti za precizno nagrizanje ili pripremu površine za nanošenje nekog materijala, poput boje ili polimera. Upotrebom plazme umesto hemijskih metoda je u mnogim industrijama moguće postići isti efekat ali na način koji ostavlja daleko manje ekološke posledice. Primene u tretmanima bioloških uzoraka, poput semena, poslednjih godina privlače pažnju kako naučnika tako i industrije u tolikoj meri da je razvijena nova oblast istraživanja pod imenom plazma-agrikultura. Unapređenje efikasnosti svih vrsta plazma tretmana zahteva pre svega dublje upoznavanje sa osobinama same plazme ali i interakcije plazme sa površinama.

Kako bi se omogućio tretman uzoraka koji su osetljivi na visoke temperature, u Laboratoriji za neravnotežne procese i primenu plazme Instituta za fiziku je razvijen asimetrični reaktor velike zapremine i cilindrične geometrije. Disertacija sadrži rezultate detaljne karakterizacije pražnjenja u ovom reaktoru u smeši gasova koja je sačinjena od 99% kiseonika (O_2) i 1 % argona (Ar). Metodom masene spektrometrije je ispitan hemijski sastav gasa i praćen je doprinos atoma i molekula kiseonika kao i atoma argona u zavisnosti od primenjene snage pražnjenja i pritiska u komori. Masenom spektrometrijom praga za jonizaciju praćena je količina pobuđenih molekula i atoma kiseonika. Derivativnim sondama su ispitane strujno naponske karakteristike sistema, frekventni sastav strujnog i naponskog signala i određen je stepen efikasnosti predaje snage pražnjenju. Snimljeni su emisijski spektri plazme a primenom metode optičke aktinometrije je izmerena apsolutna koncentracija atoma kiseonika i stepen disocijacije molekula. Kako bi se procenilo kako na osobine plazme utiče odnos površina uzemljene i napajane elektrode ali i kako blizina uzemljenog zida utiče na masene spektre i količinu pobuđenih čestica, sva merenja su rađena za dve različite dimenzije uzemljenih elektroda. Dvodimenzionalnom simulacijom je procenjeno kako će postavljanje dodatne, manje, uzemljene elektrode uticati na protok gasova kroz komoru.

Derivativnim sondama su rađene identične analize u reaktoru plan paralelne geometrije tokom pražnjenja u azotu i argonu za dva različita rastojanja između napajane i uzemljene elektrode. Sa ciljem boljeg razumevanja interakcije plazme sa površinama tretiranog uzorka, u istom reaktoru su snimljeni emisijski spektri tokom pražnjenja u tim gasovima (N_2 i Ar) i praćena je vremenska evolucija karakterističnih linija. Ova snimanja su rađena kako tokom tretmana tako i tokom pražnjenja bez uzorka u komori. Uniformnost pražnjenja u radijalnom smeru je ispitana Langmirovom sondom.

U okviru saradnje sa dve grupe iz Ljubljane, katalitičkom sondom je merena koncentracija atomskog kiseonika na tri različite pozicije, daleko od izvora jonizacije, u reaktoru mikrotalasne pobude.

Nakon karakterizacije, u sva tri reaktora je rađen tretman tekstila sa ciljem nanošenja mikrokapsula. Pored toga, u asimetričnom reaktoru je rađen i tretman semena različitih biljaka. Tretmanom semena industrijskih biljaka je pokazano kako se plazmom može uticati na klijavost i na stepen infekcije. Izlaganjem semena caričinog drveta (*paulownia tomentosa*) plazmi je pokazano kako tretman semena utiče na aktivnost enzima tokom perioda klijanja biljke.

Ključne reči: plazma na niskom pritisku, asimetrične elektrode, plazma tretmani, masena spektroskopija, optička spektroskopija

Naučna oblast: Fizika

Uža naučna oblast: Fizika jonizovanih gasova i plazme

UDK: 533.9

DIAGNOSTICS OF AN ASSYMETRICAL AND PLAN PARALLEL RADIOFREQUENT PLASMA SYSTEM WITH A GOAL OF DEFINING PLASMA CHEMICAL PROCESSES DURING TREATMENTS OF BOTH ORGANIC AND INORGNANIC SAMPLES

Abstract:

Low pressure plasmas have been used for a long time in industries such as car production, electronic industry or textile industry. Due to the specific way it interacts with the surfaces, plasma can be used for precise etching or surface preparation for the application of materials such are paints or polymers. By using plasma instead of the traditional chemical methods, in many industries, it is possible to achieve the same effect but in a way that is much more environmentally friendly. In recent years, applications in treatments of biological samples, such are seeds, have gathered attention of both scientists and the industry in such an extent that new area of research have been developed. It is called plasma-agriculture. In order to improve all kinds of plasma treatments it is necessary to achieve deeper understanding of both plasma itself and plasma-surface interactions as well.

With an aim to facilitate treatments of thermally sensitive samples, large asymmetrical plasma reactor of cylindrical geometry has been developed in Laboratory for non-equilibrium processes and application of plasmas in Institute of physics. Results of detailed characterisation of discharges in this plasma reactor, in gas mixture of 99 % oxygen (O₂) and 1 % argon (Ar), are presented in the doctoral dissertation in front of you. In order to determine chemical composition of the gasses and to track yields of O₂, O and Ar versus pressure and applied power we have applied technique of mass spectrometry. Number of excited O and O₂ particles was tracked by means of threshold ionisation mass spectrometry. Derivative probes were used in order to determine current-voltage characteristics of the system, current and voltage signal spectrum and power transfer efficiency. Plasma emission spectra were also recorded while optical actinometry was used to determine absolute O atom concentration and oxygen molecule dissociation degree. In order to assess how does the ratio of grounded to powered electrode surface is affecting plasma parameters and how does vicinity of the chamber wall is changing mass spectra, all of the measurements were performed with the two different sized grounded electrodes. Additionally, two-dimensional computer simulation was used to determine influence of additional, smaller, grounded electrode on the gas flow through the chamber.

The derivative probes were used to perform the same characterisation but of a plan parallel system during nitrogen and argon discharges at two different distances between the powered and the grounded electrodes. Optical emission spectra were recorded and distinct emission line of, both nitrogen and argon, were tracked through the time in order to deepen the understanding of interaction between the plasma and the treated sample. These recordings were performed during plasma treatment and during discharge without the sample in the chamber. Plasma uniformity in radial directions was evaluated by the Langmuir probe measurements.

Within the cooperation with two research groups from Ljubljana, oxygen atom concentration was measured by means of catalytic probe in a microwave discharge afterglow.

After all the diagnostics, textile treatments were performed in all three reactors with the aim of applying microcapsules. Besides that, seeds of various plants were treated in the asymmetrical reactor. We have shown how plasma treatment of industrial plant seeds can influence their germination and infection rate. Paulownia tomentosa seeds were exposed to the plasma and we have shown what kind of influence plasma treatments have on enzyme activity during subsequent seed germination phase.

Key words: low pressure plasma, asymmetrical electrodes, plasma treatments, mass spectroscopy, optical spectroscopy

Scientific field: Physics

Research are: Physics of ionized gases and plasma

UDC: 533.9

1. Uvod.....	1
1.1. Osobine neravnotežnih plazmi na niskim pritiscima.....	2
1.1.1. Kapacitivno spregnuta pražnjenja.....	11
1.1.2. Induktivno spregnuta pražnjenja.....	21
1.2. Dijagnostika radio-frekventnih pražnjenja na niskom pritisku.....	23
1.2.1. Masena spektroskopija.....	23
1.2.2. Električna karakterizacija radio-frekventnih pražnjenja – derivativne sonde i merenje snage.....	32
1.2.3. Optička emisiona spektroskopija i optička aktinometrija.....	34
1.2.4. Snimanje iCCD kamerom.....	35
1.2.5. Langmuirova sonda.....	36
1.3. Primene radio-frekventnih pražnjenja na niskim pritiscima.....	40
1.3.1. Primene u tretmanu tekstila.....	42
1.3.2. Primene u tretmanu semena.....	43
1.4. Zaključak.....	45
2. Asimetrično kapacitivno spregnuto pražnjenje velike zapremine.....	46
2.1. Eksperimentalna postavka.....	46
2.1.1. Asimetrični plazma reaktor.....	46
2.1.2. Derivativne sonde.....	48
2.1.3. Maseno energijski analizator.....	52
2.1.4. Masena spektrometrija praga za jonizaciju.....	57
2.1.5. Optička emisiona spektroskopija i aktinometrija.....	59
2.2. Rezultati merenja i diskusija.....	64
2.2.1. Strujno naponske karakteristike asimetričnog kapacitivno spregnutog pražnjenja.....	64
2.2.1.1. Uzemljena elektroda većeg poluprečnika.....	64
2.2.1.2. Uzemljena elektroda manjeg poluprečnika.....	72
2.2.1.3. Zaključak.....	83
2.2.2. Simulacija protoka u asimetričnom reaktoru velike zapremine.....	84
2.2.3. Masena spektrometrija.....	91
2.2.3.1. Uzemljena elektroda većeg poluprečnika.....	92
2.2.3.2. Uzemljena elektroda manjeg poluprečnika.....	97
2.2.3.3. Zaključak.....	102
2.2.4. Masena spektrometrija praga za jonizaciju.....	102
2.2.4.1. Uzemljena elektroda većeg poluprečnika.....	103
2.2.4.2. Uzemljena elektroda manjeg poluprečnika.....	105
2.2.4.3. Zaključak.....	107
2.2.5. Optička emisiona spektroskopija i aktinometrija.....	108
2.2.5.1. Uzemljena elektroda većeg poluprečnika.....	108
2.2.5.2. Uzemljena elektroda manjeg poluprečnika.....	113
2.2.5.3. Zaključak.....	118
2.3. Primene asimetričnog pražnjenja velike zapremine u tretmanima tekstila i semena.....	120
2.3.1. Eksperimentalna postavka.....	121
2.3.2. Uticaj plazme na aktivnost enzima caričinog drveta.....	122
2.3.3. Tretman komercijalnih semena u cilju povećanja klijavosti i smanjenja zaraze.....	126
2.3.4. Tretman pamučne tkanine sa ciljem nanošenja mikrokapsula.....	128

Sadržaj

2.3.5. Zaključak.....	134
2.4. Zaključak.....	134
3. Plan-paralelno kapacitivno spregnuto pražnjenje.....	137
3.1. Eksperimentalna postavka.....	137
3.1.1. Plan-paralelni plazma reaktor.....	137
3.1.2. Derivativne sonde.....	138
3.1.3. OES i aktinometrija.....	139
3.1.4. Langmuirova sonda.....	140
3.2. Rezultati merenja i diskusija.....	142
3.2.1. Derivativne sonde.....	142
3.2.2. Optička emisiona spektroskopija.....	162
3.2.3. Langmuirova sonda.....	183
3.2.4. Zaključak.....	186
3.3. Primene plan paralelnog pražnjenja u tretmanu tekstila.....	187
3.3.1. Eksperimentalna postavka.....	187
3.3.2. Rezultati tretmana.....	188
3.3.3. Zaključak.....	194
3.4. Zaključak.....	194
4. Mikrotalasno pražnjenje.....	197
4.1. Eksperimentalna postavka.....	197
4.1.1. Plazma reaktor za mikrotalasna pražnjenja.....	197
4.1.2. Katalitička sonda.....	198
4.2. Rezultati merenja i diskusija.....	201
4.2.1. Katalitička sonda.....	201
4.2.2. Zaključak.....	207
4.3. Primene u tretmanu tekstila.....	207
4.3.1. Eksperimentalna postavka.....	208
4.3.2. Rezultati tretmana.....	209
4.3.3. Zaključak.....	216
4.4. Zaključak.....	217
5. Zaključak.....	218
6. Literatura.....	222

1 UVOD

Osnovna tema ove disertacije su radiofrekventna električna pražnjenja u gasovima na niskom pritisku. Pored produbljivanja znanja o fundamentalnim osobinama ovakvih plazmi, glavni cilj je bio da se nađu uslovi za najoptimalniji tretman osetljivih uzoraka, poput semena biljaka ili tkanina, koji ne trpe visoke temperature. Pokazano je da se tretiranjem semena može uticati na njihovu klijavost kao i na aktivnost određenih enzima nakon što seme proklija, dok se izlaganjem tekstila zračenju iz plazme omogućuje uspješnije nanošenje mikrokapsula. Podešavanjem uslova tretmana poput pritiska, primenjene snage i vremena koje uzorci provedu u plazmi omogućen je izbor parametara kojima se ostvaruje da se željeni efekti postignu uz najmanji utrošak vremena, energije i gasova, što je veoma važno za korišćenje ovih procesa u industriji, kako sa finansijske tako i sa ekološke tačke gledišta.

Za potrebe ove disertacije su korišćena tri kapacitivno spregnuta reaktora. Dva cilindrična reaktora različitih dimenzija koji su već uspešno korišćeni u tretmanima tekstila i semena [1], [2] a koji su konstruisani tako da obezbeđuju blage uslove tretmana bez pojave strimera i jedan, manji, reaktor plan paralelne geometrije kojim je moguće postići nešto intenzivnije plazme. Za dijagnostiku pražnjenja je korišćeno nekoliko dijagnostičkih metoda. Standardna masena spektrometrija je primenjena kako bi se precizno odredilo prisustvo svih vrsta u plazmi i njihov doprinos u ukupnom broju čestica, dok je masena spektrometrija praga za jonizaciju primenjena kako bi se procenilo prisustvo pobuđenih vrsta koje su važne za tretmane, kako bioloških tako i nebioloških uzoraka. Optička spektroskopija i optička aktinometrija će biti primenjene kako bi se dobile apsolutne koncentracije i stepen disocijacije određenih vrsta. Derivativnim sondama izvršiće se električna karakterizacija sistema ali i dobiti odgovor na pitanja o efikasnosti sistema prilikom predaje snage plazmi. Langmirovom sondom ispitaće se prostorne raspodele plazmenog potencijala, koncentracije elektrona i njihovih temperatura. Dodatna merenja i tretmani tekstila će biti urađeni i u mikrotalasnom reaktoru.

U uvodnom delu disertacije, odnosno u prvoj glavi, biće napravljen kraći teorijski uvod u fiziku plazme. S obzirom na to da su u prezentovanim rezultatima korišćene kapacitivno spregnute radio frekventne plazme, poseban akcenat će biti na pražnjenjima sa naizmničnom pobudom. Takođe će biti razjašnjen princip rada svake od primenjenih dijagnostičkih metoda uključujući njihove prednosti i ograničenja. Poslednji deo uvoda će biti posvećen primenama ovakvih plazmi uz poseban osvrt na tretmane tekstila i bioloških uzoraka.

Druga glava će biti posvećena pražnjenjima u asimetričnom reaktoru. Biće opisana njegova konstrukcija i kompletna eksperimentalna postavka. Opisaćemo proceduru merenja maseno energijskim analizatorom i prikazati dobijene rezultate. Takođe ćemo se osvrnuti na strujno naponske osobine ovog sistema i njegovu efikasnost u predaji snage plazmi. Prikazaćemo dobijene spektre optičke emisije i rezultate merenja dobijene primenom metode optičke aktinometrije. S obzirom na to da je jedan deo merenja bio urađen sa dodatnom uzemljenom elektrodom, manjeg poluprečnika, bilo je potrebno uraditi procenu uticaja njenog postavljanja na protok gasova u komori što je urađeno dvodimenzionalnom simulacijom a rezultati će biti opisani u ovoj glavi. Njen poslednji deo će biti posvećen primenama ovakvog tipa reaktora u tretmanima semena Caričinog drveta i tekstilnih uzoraka.

Kapacitivno spregnuti plan paralelni reaktor će biti analiziran u trećoj glavi. Pored detaljne eksperimentalne postavke, i za ovaj tip reaktora, će biti pokazane njegove strujno-naponske karakteristike i efikasnost predaje snage plazmi. Pokazaćemo prostorne raspodele veličina dobijenih merenjem Langmirovom sondom, optičke spektre i vremensku evoluciju linija određenih vrsta tokom pražnjenja sa i bez uzoraka u komori. U ovom reaktoru je obavljen i tretman tekstila radi primene mikrokapsula, čemu će biti posvećen poslednji deo treće glave.

Mikrotalasni izvor koji se nalazi u Jožef Štefan institutu u Ljubljani će biti opisan u četvrtoj glavi. Pored detalja vezanog za geometriju i konstrukciju reaktora u ovoj glavi će biti opisan način rada katalitičke sonde i konkretna procedura merenja kojom su dobijene koncentracije atomskog kiseonika. Jedan deo ove glave će biti posvećen tretmanima tekstila u ovom reaktoru. Oni su rađeni u okviru saradnje tri istraživačke grupe (Laboratorije za tehnologije površina instituta Jožef Štefan iz Ljubljane, odseka za Tekstile, grafiku i dizajn Prirodno-tehničkog fakulteta u Ljubljani i Laboratorije za neravnotežne procese i primenu plazme Instituta za fiziku u Beogradu) koja je, pored ostalog, bila fokusirana i na tretmane tekstila.

Rezultati istraživanja predstavljenih u okviru disertacije će biti sumirani u petoj glavi. Iznećemo opšte zaključke vezane za analizirana pražnjenja. Upoređićemo plazme ostvarene u različitim tipovima reaktora. Diskutovaćemo o njihovim specifičnostima, sličnostima i razlikama i razmotriti kako se to prenosi na mogućnost njihove primene u tretmanima osetljivih uzoraka. Iznećemo i mišljenje o tome koji je skup spoljnih parametara pražnjenja, u okviru testiranih, najbolje primeniti u tretmanima kako bi se dobili željeni efekti a da se izbegne oštećenje uzorka i upotrebi najmanje vremena, energije i gasova.

1.1 OSOBINE NERAVNOTEŽNIH PLAZMI NA NISKIM PRITISCIMA

Za istraživanja u oblasti fizike plazme, u modernom obliku, možemo da kažemo da su počela 1928. godine kada je Langmir (Irving Langmuir) prvi put upotrebio reč plazma kako bi njom opisao jonizovani gas [3]. Danas se pod pojmom plazma podrazumeva gas za koji može da se kaže da je u globalu kvazi-neutralan ali u kome se nalaze slobodni nosioci naelektrisanja poput jona i elektrona. Sa druge strane kada se govori o jonizovanom gasu, uslov kvazi neutralnosti ne mora da važi.

U plazmama koje su na makroskopskom nivou neutralne u samoj blizini nosioca naelektrisanja će postojati određeno električno polje koje se može dobiti polazeći od Poasonove jednačine [3] i ono iznosi:

$$\operatorname{div} E = e \frac{n_p - n_e}{\epsilon_0}. \quad (1.1)$$

Izraz se zove Gausov zakon i sa E je obeleženo polje, e je elementarno naelektrisanje, ϵ_0 je dielektrična konstanta vakuuma a sa n_p i n_e su obeležene koncentracije pozitivnih i negativnih nosioca naelektrisanja. Odavde se vidi da će polje biti jednako nuli kada su koncentracije jona i elektrona jednake, što je na makroskopskom nivou zadovoljeno.

Ukoliko operator divergencije električnog polja zapišemo u obliku V^2/L^2 gde je sa L označeno rastojanje tokom koga se menja razlika potencijala V [4], formula 1.1 dobija sledeći oblik:

$$\frac{eV}{kT_e} = L^2 \frac{(n_e - n_p)e^2}{\epsilon_0 kT_e}. \quad (1.2)$$

Karakteristična dužina na desnoj strani jednačine se naziva Debajevo rastojanje ili Debajev radijus i predstavlja prostor na kome je kvazineutralnost narušena, odnosno unutar koga postoji značajno razdvajanje elektrona i jona i najčešće se piše u sledećem obliku:

$$\lambda_d = \left(\frac{\epsilon_0 kT_e}{n_e e^2} \right)^{1/2}. \quad (1.3)$$

Ukoliko je koncentracija elektrona veoma velika, Debajev radijus će biti mali pa će i devijacija od kvazi neutralnosti biti mala. U ovakvom slučaju će, pod dejstvom električnog polja, elektroni i joni da se kreću zajedno [5]. Sa druge strane ovog ekstrema je situacija u kojoj je ova koncentracija veoma mala i tada će se joni i elektroni kretati praktično nezavisno jedni od drugih, odnosno kvazineutralnost će biti narušena. Za praktične primene se često koristi formula u kojoj su zamenjene vrednosti fizičkih konstanti i ona ima sledeći oblik:

Uvod

$$\lambda_d \approx 743 \sqrt{\frac{T_e}{n_e}} [\text{cm}]. \quad (1.3)$$

Primeru radi, za koncentraciju elektrona se može ubaciti vrednost od 10^{17}m^{-3} a za njihovu energiju 4eV, što može da odgovara primenjenim plazmama u industriji, i tada se za Debajev radijus dobija vrednost od oko 50 μm .

U gasu pri normalnim uslovima ne može da dođe do nastanka plazme jer u takvom stanju on ne može da provodi struju odnosno ponaša se kao izolator. Za nastanak plazme potrebno je da se u gasu pored neutralnih nađe i određen broj naelektrisanih čestica koje se stvaraju jonizacijom. U većini slučajeva do jonizacije dolazi tako što elektron dobije dovoljno energije da napusti atom ili molekul, koji onda postaju jon – teška čestica, nosioc pozitivnog naelektrisanja. Jedan od procesa kojim ovo može da se realizuje je tako što će atom biti pogođen fotonom koji ima dovoljno energije da izbije elektron i to se onda zove direktna foto jonizacija:



Takođe, može da se desi da foton neće imati dovoljno energije za jonizaciju ali će dovesti atom u neko od pobuđenih stanja posle čega do jonizacije može da dovede drugi foton ili se ona dešava prilikom sudara sa nekim slobodnim elektronom dovoljne energije. U tom slučaju govorimo o stepenastoj jonizaciji koja se događa u dva koraka:

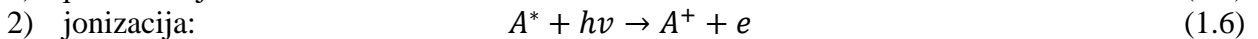
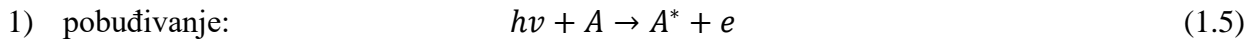

Pobuđena stanja se uglavnom vrlo brzo gasu – deekscituju i tako prelaze u osnovno stanje. Međutim, zbog selekcionih pravila koja zabranjuju radijativnu deekscitaciju sa određenih nivoa, postoje pobuđena stanja čija su vremena života veoma velika, znatno duža od ostalih pobuđenih stanja i njih nazivamo metastabilnim. Atomi u metastabilnim stanjima imaju dovoljno dugo vreme života da efiksno učestvuju u procesima stepenaste jonizacije. Do jonizacije može da dođe i u sudaru između elektrona i atoma ili između dva atoma, pri čemu u oba slučaja mogu da postoje kako direktna tako i stepenasta jonizacija:



Još jedan od sudarnih procesa u kojima može nastati slobodan elektron je sudar jona i neutrala:



Proces u kome slobodan elektron nastaje prilikom raspada molekula na atome ili na više molekula se naziva disocijativna jonizacija. Postoji veliki broj mogućih načina za ovakve procese ali neke od najvažnijih možemo predstaviti sledećim formulama:



S obzirom na to da se svi ovi procesi događaju u samom gasu, odnosno unutar njegove zapremine, njih nekad nazivamo i zapreminskim.

Sa druge strane, postoje i površinski procesi tokom kojih joni ili elektroni nastaju ili nestaju direktno sa površine koja ograničava gas. U laboratorijskim uslovima oni se najčešće događaju na negativno naelektrisanjoj elektrodi, a pomenućemo četiri najvažnija. Fotoelektronska emisija je proces

tokom koga foton izbija elektron sa elektrode. Ukoliko elektron napusti katodu nakon sudara sa masivnom česticom poput jona, neutralnog atoma ili molekula govorimo o sekundarnoj emisiji. Druga mogućnost je da elektron udarom izbije jon sa anode, ali se to u praksi znatno ređe događa. Može da se desi i da je elektroda toliko zagrejana da njena termalna energija bude toliko velika da elektroni mogu da napuste njenu površinu. Ovaj proces se naziva termoelektronska emisija. Poslednji proces nastajanja slobodnih elektrona sa katode koji ćemo pomenuti je emisija pod dejstvom polja. Kao što iz imena može da se pretpostavi, potrebnu energiju će u ovom slučaju elektron „pokupiti“ od električnog polja na površini elektrode.

Pored procesa u kojima nosioci naelektrisanja nastaju postoje i oni u kojima se njihov broj smanjuje. Bez obzira na tip plazme i odabir gasova balans u ovim procesima je od izuzetne važnosti kako za stabilnost samog pražnjenja tako i za uticaj na kompletnu plazma hemiju čime se direktno određuje mogućnost primene takvih plazmi. Jedan od osnovnih procesa u kome se smanjuje broj naelektrisanih čestica je radijativna rekombinacija u kome se elektron vezuje za pozitivan jon a višak energije izbacuje u obliku fotona (jednačina 1.14). Neutral koji se dobije može da bude u svom osnovnom ili u nekom od pobuđenih stanja. Ovakvi atomi ili molekuli se nakon nekog vremena radijativnom deekscitacijom odnosno ponovnim emitovanjem fotona spontano vraćaju u svoje osnovno stanje (jednačina 1.15).



Ukoliko pri rekombinaciji elektrona i jona ne dolazi do emisije fotona, zbog zakona očuvanja energije i impulsa, sudar koji nastaje je elastičan i čestice iz njega izlaze nepromenjene. Da bi se rekombinacija dogodila višak energije, kroz promenu brzine odnosno zagrevanje, mora da preuzme treći učesnik sudara (jednačina 1.16) što je uslov za odigravanje ovog procesa. Na višim pritiscima to može da bude još jedna neutralna čestica ali ulogu trećeg tela može da preuzme i zid komore za pražnjenje ili elektroda. Pobuđeni atomi se često javljaju kao posledica ove vrste sudara [4].

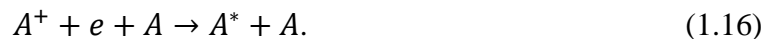

Atome ili molekule koji i u svom neutralnom stanju imaju visok afinitet prema elektronu i mogu da zadrže elektron i tako postanu negativni joni nazivamo elektronegativnim. Ovakav način nastajanja negativnog jona se zove elektronski zahvat a može da se prikaže na sledeći način:



Specifičan slučaj je ako prilikom disocijacije molekula dođe do zahvata elektrona . Tada govorimo o disocijativnom zahvatu:



Veoma važna reakcija može da se desi ukoliko do sudara dođe između elektrona velike energije i molekula. O nekim reakcijama ove vrste će nešto više reći kasnije ali je za sve njih zajedničko da energija elektrona može da se „potroši“ na cepanje veza u molekulu. Na taj način iz dvoatomskog molekula nastaju dva atoma u procesu koji se zove disocijacija ili sudarna disocijacija (j-na 1.19 i 1.11). Bitno je napomenuti da kroz ove dve reakcije u plazmama nastaje najveći broj hemijski aktivnih radikala koji imaju veliku ulogu u primenama. Kompletnosti radi, samo ćemo napomenuti da elektron ne mora da bude jedini uzročnik ovakvih reakcija već to mogu biti i foton, drugi molekul, atom ili jon.



Disocijativna rekombinacija je proces u kome učestvuju molekulski joni. Naime, može da se desi da elektron velike energije naiđe na pozitivan jon molekula i da se tom prilikom nakon sudara dobiju dva atoma. Ovo može da se predstavi kao:

$$e + A_2^+ \rightarrow 2A. \quad (1.20)$$

Kretanje naelektrisanih čestica može da nastane kao posledica postojanja električnog ili magnetnog polja, što se naziva drift. Pod dejstvom električnog polja se naelektrisane čestice kreću u smeru elektrode suprotnog znaka dok se pod dejstvom magnetnog polja kreću po kružnicama koje su normalne na linije polja. Ukoliko u plazmi deluju i električno i magnetno polje, putanje čestica će izgledati kao cikloide u kojima je smer ukupne brzine u svakom trenutku normalan i na \vec{E} i na \vec{B} [6]. Naelektrisane, ali i ostale čestice, mogu da napuste oblast pražnjenja i difuzijom što se najčešće događa zbog postojanja velikog gradijenta pritiska.

Sada, kada smo definisali neke od najvažnijih procesa za nastajanje, nestajanje i kretanje kako naelektrisanih tako i neutralnih čestica, možemo na kratko da se pozabavimo i njihovom temperaturom i koncentracijom. Na slici 1.0.1 je na grafiku temperatura i koncentracija naelektrisanih čestica prikazana praktično sva poznata materija u svemiru [7]. Što se više krećemo ka desnoj strani ove slike nailazimo na materiju koja je sve više jonizovana i sve više spregnuta, odnosno u kojoj je odnos naelektrisanih čestica prema neutralima sve veći. Tako je, na primer, kora neutronske zvezde sačinjena od potpuno jonizovanih atoma gvožđa i elektrona i nalazi se na ekstremno velikoj temperaturi.

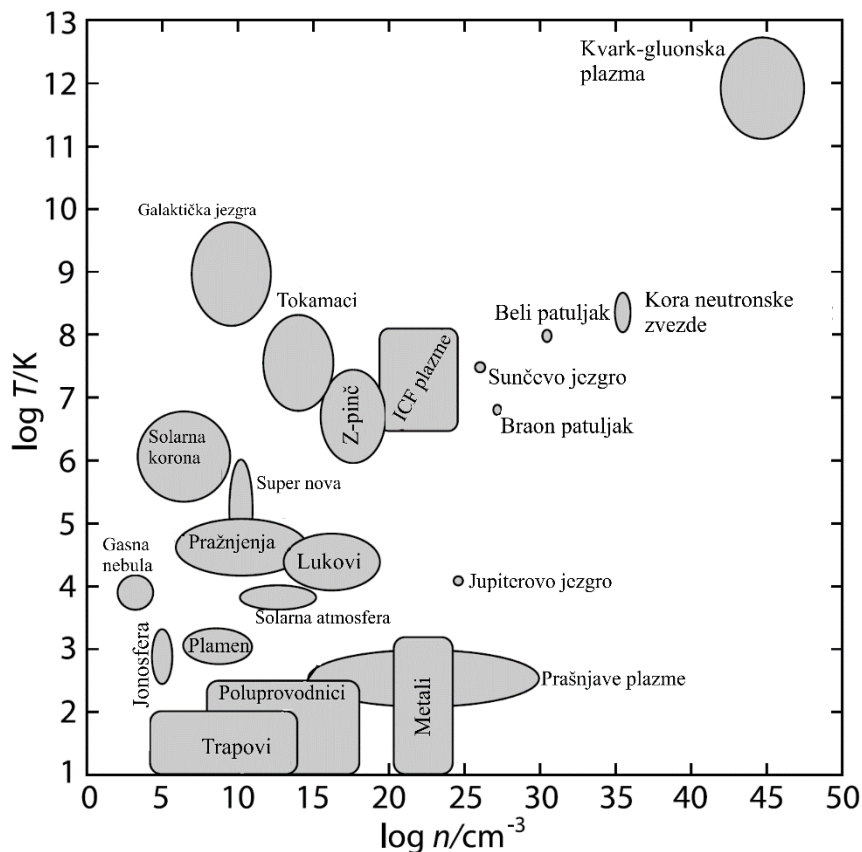

Slika 1.0.1 Različiti tipovi plazme i materije u zavisnosti od temperature i koncentracije [7].

Međutim, kada se govori o temperaturi plazme treba biti veoma obazriv. Ukoliko bi hteli da potpunom pražnjenju dodelimo jedno T , to bi značilo da se sve njene komponente nalaze na istoj temperaturi odnosno da postoji termodinamička ravnoteža. Ovo u zemaljskim uslovima u eksperimentima važi samo u nekim specifičnim slučajevima, kao što su na primer fuzione plazme u sistemima poput tokamaka, stelaratora, plazma pinčeva i sličnih [5] ali se i kod njih češće govori o

lokalnoj termodinamičkoj ravnoteži. U skoro svim ostalim slučajevima će različite vrste čestica imati različite srednje energije, odnosno temperature. S aspekta termodinamike, za sisteme kod kojih se znatno razlikuju temperature različitih čestica uvodi se pojam neravnotežnog sistema, odnosno u našem slučaju neravnotežne plazme, koja je tema ove disertacije. Osim toga što je bitno da se razdvoje srednje energije po tipu čestica, često ih je potrebno posebno razmatrati i po stepenima slobode poput translacionog, vibracionog ili rotacionog. Ipak, iz praktičnih razloga se temperatura elektrona i njihova koncentracija često koriste kako bi se opisale plazme, bez obzira na njihovu prirodu. Na slici 1.0.2 je prikazana podela plazmi prema ovom kriterijumu sa naznačenim Debajevim radijusom [6]. Temperature se u plazma fizici obično izražavaju u elektron voltima (eV) a može da se kaže da energija od jednog elektron volta odgovara temperaturi od okvirno 11600 K [5].

Odnos temperatura različitih komponenti u neravnotežnoj plazmi može biti veoma komplikovan ali u opštem slučaju najvišu temperaturu imaju elektroni (T_e). U najvećem broju praktičnih slučajeva, temperature elektrona se kreću između 1 i 20 eV sa srednjom vrednošću od svega nekoliko eV. Za njom ide temperatura vibracionih ekscitacija molekula (T_v), dok najmanju temperaturu u sistemu obično nose teške neutralne čestice (T_0) – red veličine nekoliko mV. Pošto se u plazmama koje se proučavaju u ovom radu one nalaze na sobnoj temperaturi, ova temperatura se koristi i kada se govori o temperaturi gasa. Istog reda veličine su još i temperature jona (T_i) i rotacionih ekscitacija molekula. Kada su ispunjeni svi ovi uslovi, neravnotežne plazme se nazivaju još i netermalne. Procena razlike između temperature elektrona i teških čestica, u slabo jonizovanim plazmama, može da se dobije iz kvadrata odnosa električnog polja i pritiska odnosno:

$$T_e - T_i \sim \left(\frac{E}{p}\right)^2. \quad (1.21)$$

Jedan primer neravnotežnih plazmi u prirodi nastaje kada u višim slojevima atmosfere naelektrisane čestice iz sunčevog vetra interaguju sa zemljinim magnetnim poljem koje ih usmerava ka svojim polovima gde nastaje fenomen poznat kao *Aurora Borealis*.

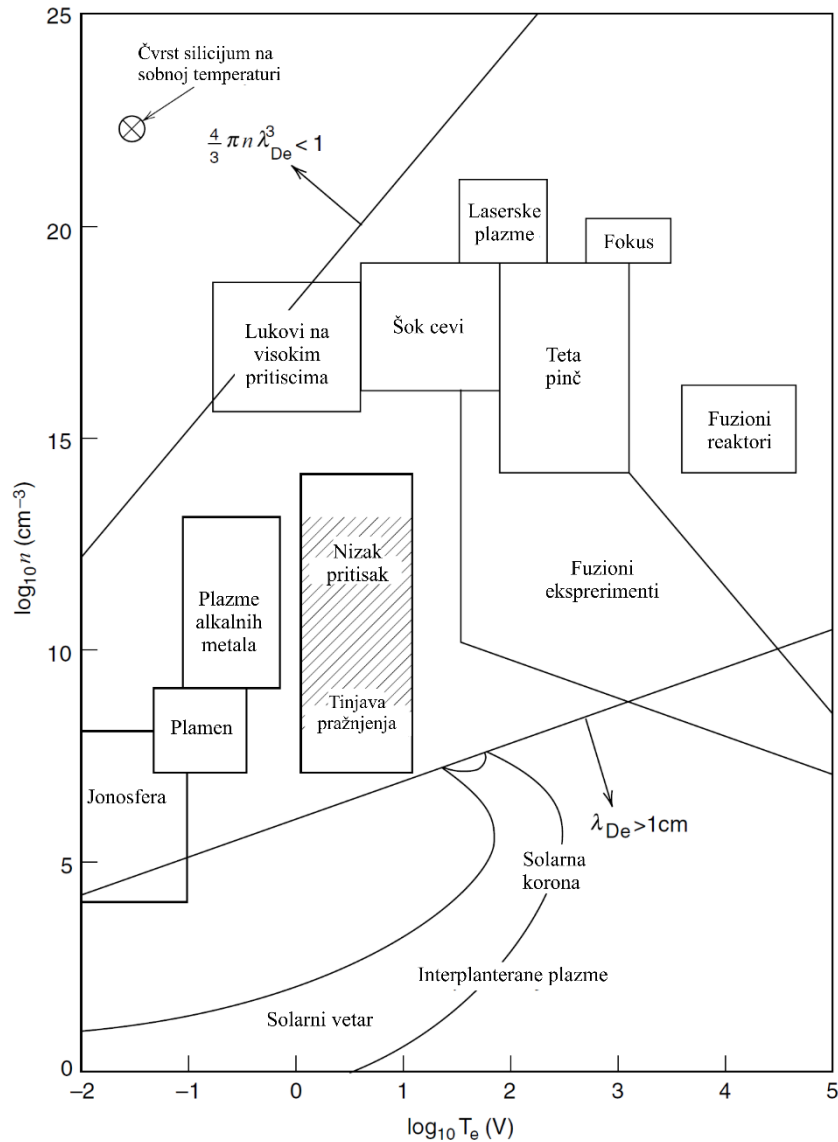

Slika 1.0.2 Podela plazmi u zavisnosti od temperature i koncentracije elektrona [6].

S druge strane da bi plazma nastala u laboratorijskim uslovima u gasu, česticama treba da se preda određena količina energije koja bi bila dovoljna da u gasu dovede do jonizacije. Postoji mnogo načina da se ovo uradi ali ćemo pomenuti tri najvažnija koja se koriste u najvećem broju eksperimenata. Najmanje korišćen način je upotreba udarnih cevi (eng. shock tubes) u kojima se koristi kinetička energija gasa. One se, pored problematike nevezane za fiziku plazme, najčešće koriste u ispitivanjima plamena. Drugi metod, koji se značajno više koristi, podrazumeva upotrebu velike količine fotona kako bi došlo do jonizacije, najčešće korišćenjem lasera. Laserski indukovane plazme imaju veoma široko polje upotrebe uključujući proizvodnju i manipulaciju nano česticama, depoziciju tankih filmova, detektovanje bioloških uzoraka i eksploziva [8]. Važno je pomenuti i njihove primene u dijagnostičkoj metodi poznatoj kao LIBS (laser induced breakdown spectroscopy) i u jednom delu eksperimenata vezanih za nuklearnu fuziju. Treći i najčešće korišćen metod je primenom napona između dve elektrode koji je korišćen i u našim eksperimentima.

Da bi se na ovaj način formirala plazma, odnosno da bi u prostoru između elektroda došlo do proboja i električnog pražnjenja potrebno je da se između njih primeni napon koji je veći ili jednak probojnom naponu. Empirijski je utvrđena veza probojnog napona, pritiska i rastojanja između elektroda prema sledećoj formuli[9]:

Uvod

$$V_t = \frac{B(pd)}{C + \ln(pd)} \quad (1.22)$$

u kojoj je korišćeno:

$$\frac{E_t}{p} = \frac{B}{C + \ln pd} \text{ i } C = \ln \frac{A}{\ln^{1/\gamma+1}}. \quad (1.23)$$

U ovim formulama su sa A i B obeležene konstante koje se dobijaju eksperimentalnim putem i karakteristika su određenog gasa, sa γ je označen koeficijent sekundarne emisije, p je pritisak a d je rastojanje između dve elektrode. Može da se primeti da dobijena jednačina zavisi samo od proizvoda $p \cdot d$. Na atmosferskom pritisku ovaj napon iznosi 10^6 V/m dok je na manjim pritiscima ova veličina ima svoj minimum. Po naučniku koji se bavio probojima u gasovima (Friedrich Paschen) kriva zavisnosti V_t od pd nosi naziv Pašenova kriva a jedan primer takve krive, za proboj u vodenoj pari [10], je prikazan na slici 1.0.3.

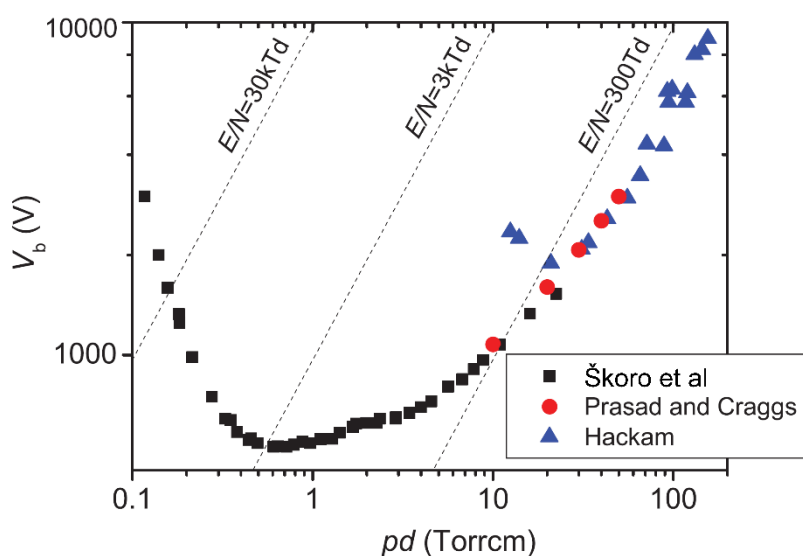

Slika 1.0.3 Primer Pašenove krive za proboj u vodenoj pari [10].

Ukoliko pretpostavimo da se elektron kreće u konstantnom električnom polju od katode ka anodi, koje se nalaze na rastojanju d i na tom putu izvrši određen broj jonizacija, što je opisano koeficijentom α , a zatim da dobijeni joni koji se kreću ka katodi udarom u nju proizvedu određen broj elektrona na površini, što se opisuje koeficijentom γ , onda se uslov za samostalno pražnjenje može napisati u sledećem obliku:

$$\gamma(e^{\alpha d} - 1) = 1. \quad (1.24)$$

Na taj način će svaki elektron koji je prešao put od katode do anode obezbediti stvaranje bar još jednog elektrona, odnosno njihov broj će rasti tokom vremena.

Jasno je da centralnu ulogu u održavanju pražnjenja igraju naelektrisane čestice, iako koncentracije jona n_i i elektrona n_e mogu biti i pet redova veličine manje od koncentracije neutrala [6]. Zapravo, s obzirom na činjenicu da je masa elektrona veoma mala, u određenim situacijama kada postoje brzo-promenljiva električna polja i/ili pritisci pri kojima je broj sudara između čestica odgovarajući, upravo će oni moći da preuzmu najveći deo energije koja se preko električnog polja predaje plazmi povećavajući svoju kinetičku energiju. Usled toga, plazma će postati neravnotežna pri čemu je $T_e \gg T_i$. Energija će se dalje, kroz sudare, prenositi i na teške čestice. Treba imati u vidu da će zbog velike razlike u masama u svakom sudaru sa jonom ili neutralom elektron moći da preda samo

mali deo svoje energije. S druge strane, energija će se znatno efikasnije prenositi u sudarima između čestica iste ili slične mase kao što su sudari između dva jona, jona i neutrala ili teške čestice sa zidom.

Energije elektrona koje se na ovaj način postižu su, u srednjem, manje od pragova koji su potrebni da se izvrše jonizacija ili disocijacija. Međutim, do ovih procesa će ipak doći jer ta energija podleže određenoj raspodeli. Na slici 1.0.4 je prikazana jedna takva raspodela na kojoj se vide odnosi srednje energije i pragova za disocijaciju i jonizaciju. Usled postojanja takozvanog repa funkcije distribucije energije na visokim energijama, postoje elektroni sa energijama koje će biti dovoljne da pokrenu pomenute procese zbog čega će upravo elektroni diktirati kompletnu plazma hemiju. U realnosti će ove raspodele odstupati od Maksvelove.

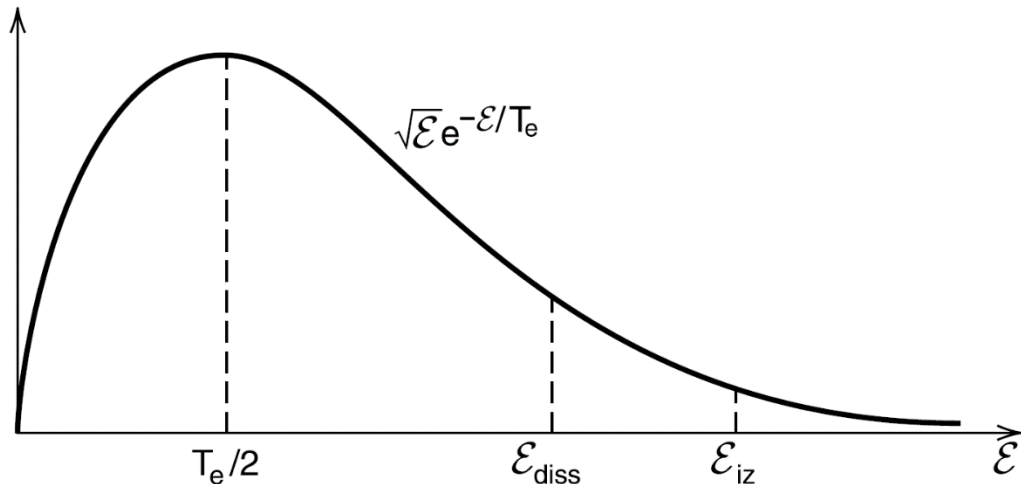

Slika 1.0.4 Raspodela elektrona po energijama [6], samo visokoenergijski elektroni učestvuju u jonizacijama i disocijacijama.

Osvrnimo se sada na oblast interakcije plazme sa površinom odnosno na prielektroodnu oblast (*eng sheath*). S obzirom na znatno veću mobilnost jona u odnosu na elektrone, za očekivati je da bi mnogo veći broj ovih lakih čestica trebalo da se iz plazme kreće ka graničnoj oblasti. Ako bi se ovo desilo, ili bi neutralnost vrlo brzo bila narušena na makroskopskom nivou ili bi se pražnjenje ugasilo zbog velikog gubitka neelektrisanih čestica. Da do toga ne bi došlo, centralni deo plazme mora da bude na nešto pozitivnijem potencijalu u odnosu na okolne površine – zidove kako bi se zadržali elektroni u pražnjenju i izjednačili fluksevi pozitivnih i negativnih čestica. Prateći Gausov zakon (j-na 1.1), vidi se da u ovoj oblasti n_i treba da bude veće od n_e kako bi rezultujući potencijal opadao sa približavanjem graničnoj površini. Primer prostorne raspodele koncentracija naelektrisanih čestica u prielektroodnoj oblasti je dat na slici 1.0.5. Iz do sada izloženog bi se očekivalo da se ovaj pad napona i koncentracija događa na rastojanju čija bi dužina bila okvirno jednaka Debajevom radijusu ali ono u praksi iznosi nekoliko λ_D [4], [6].

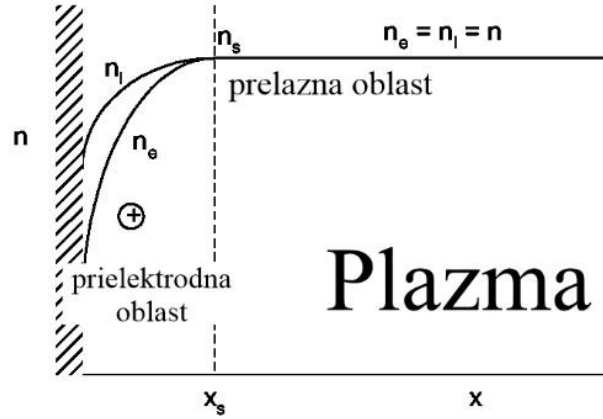

Slika 1.0.5 Pad koncentracije elektrona i jona u prielektrodnoj oblasti [4].

Ukoliko pretpostavimo da za elektrone važi Maksvelova distribucija energije, odnos njihovih koncentracija u prielektrodnoj oblasti (n_e) i na njenoj granici (n_s) može da se predstavi kao:

$$\frac{n_e}{n_s} = \exp\left(\frac{eV}{kT_e}\right). \quad (1.25)$$

Da bismo dobili koncentracije jona, pretpostavićemo da oni u prielektrodnoj oblasti ne nastaju niti nestaju, odnosno da su njihovi fluksevi jednaki na ivici ove oblasti i u njoj:

$$n_i v_i = n_s v_s \quad (1.26)$$

gde se indeksi i odnose na prielektrodnu oblast a indeksi s na njenu ivicu. Ovde je pretpostavljeno da joni na pomenutoj granici imaju neku konačnu brzinu v_s . Iz zakona očuvanja energije može da se dobije sledeće:

$$\frac{mv_i^2}{2} + eV = \frac{mv_s^2}{2}. \quad (1.27)$$

Napon V potiče od razlike potencijala u glavnom odnosno centralnom (eng *bulk*) delu plazme. Kombinovanjem dve poslednje jednačine dolazimo do:

$$\frac{n_i}{n_s} = \frac{1}{(1 - 2eV/Mv_s^2)^{1/2}}. \quad (1.28)$$

Jednačine 1.25 i 1.27 moraju da važe i za jako male promene u potencijalu. U tom slučaju možemo da ih razvijemo u Tejlorov red. Ukoliko se podsetimo da V mora da bude negativno i da treba da važi uslov $n_i > n_e$, može da se dobije:

$$\frac{e|V|}{Mv_s^2} < \frac{e|V|}{kT_e} \quad (1.29)$$

Odakle proizilazi uslov za „ulazak“ u prielektrodnu oblast:

$$v_s > \left(\frac{kT_e}{M}\right)^{1/2} \quad (1.30)$$

koji se još zove i Bomov kriterijum prielektrodne oblasti (*Bohm sheath criterion*).

Između aktivnog dela pražnjenja (eng *bulk*) i prielektrodne oblasti (eng *sheath*) postoji jedan region plazme u kome joni dobijaju usmerenu brzinu i koji se naziva prelazna oblast (eng *presheath*). Električno polje u njoj je dovoljno malo da kvazineutralnost ostaje da važi a njene dimenzije (u zavisnosti od pritiska odnosno srednjeg slobodnog puta čestica) mogu da budu uporedive i sa dimenzijom same plazme. Računanjem kinetičke energije usmerenog kretanja jona iz Bomovog

kriterijuma, dobija se pad napona od $1/2kT_e$ između centralnog dela pražnjenja i granice prielektrodne oblasti. Uz pretpostavku Maksvelove raspodele energije elektrona a uzimajući u obzir da je kvazineutralnost očuvana, može da se dobije okvirni uslov za koncentraciju naelektrisanih čestica na granici prielektrodne i prelazne oblasti:

$$n_s = n_0 e^{-1/2} = 0.6n_0 \approx \frac{1}{2}n_0 \quad (1.31)$$

gde je sa n_0 obeležena koncentracija nosilaca naelektrisanja u centralnom delu plazme ($n_0=n_i=n_e$).

1.1.1 KAPACITIVNO SPREGNUTA PRAŽNJENJA

Kapacitivno spregnuta pražnjenja (*eng* Capacitively Coupled Plasmas - CCP) su pražnjenja naizmenične pobude koja su ime dobila po blokirajućem kondenzatoru (C_b) koji se nalazi između izvora napajanja i komore za pražnjenje. Svrha ovog kondenzatora je da blokira prolaz svih jednosmernih (DC) signala od napajanja ka plazmi. Skica jednog ovakvog sistema nalazi se na slici 1.1.1.

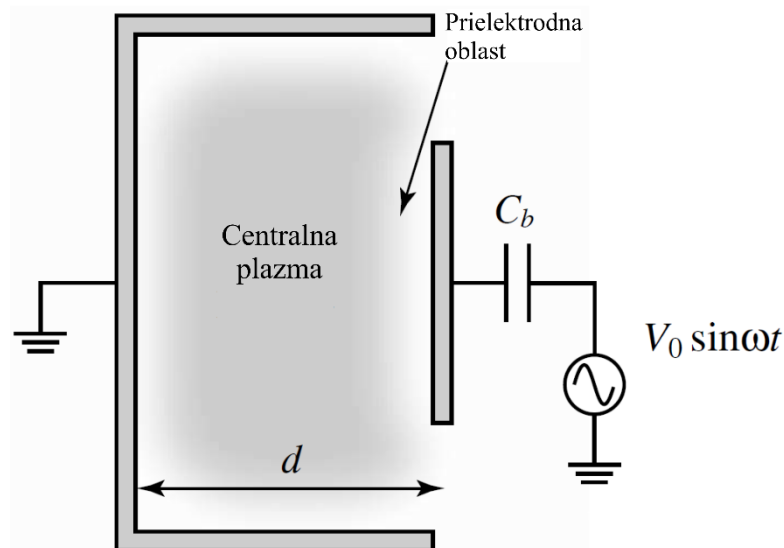

Slika 1.1.1 Skica kapacitivno spregnutog plazma reaktora [3]

Napon održavanja plazme u ovom reaktoru jednak je razlici napona koji daje izvor napajanja i napona na oblogama blokirajućeg kondenzatora:

$$V_{od}(t) = V_{rf}(t) - \frac{1}{C_b} \int_{-\infty}^t I_T(t) dt. \quad (1.32)$$

Gde je $V_{rf}=V_0 \sin(\omega t)$ a I_T predstavlja ukupnu struju kroz kondenzator.

Važan deo svakog sistema za napajanje neravnotežnih plazmi je kolo za prilagođenje čija je uloga da se korigovanjem izlazne impedanse izvora preda najveća moguća snaga plazmi. Jedan primer takvog kola je prikazan na slici 1.1.2.

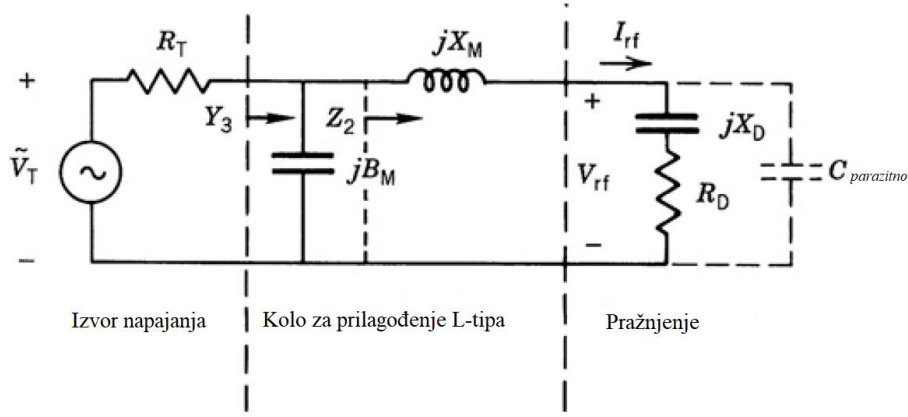

Slika 1.1.2 Šematski prikaz kola za prilagođenje L-tipa [6]

Vremenski usrednjena snaga koja se predaje kolu može da se napiše kao:

$$\bar{P} = \frac{1}{2} \operatorname{Re}(\widetilde{V}_{rf} \widetilde{I}_{rf}) \quad (1.33)$$

gde su:

$$\widetilde{I}_{rf} = \frac{\widetilde{V}_T}{R_T + R_D + jX_D} \quad (1.34)$$

$$\widetilde{V}_{RF} = \widetilde{I}_{RF}(R_D + jX_D). \quad (1.35)$$

odakle sledi:

$$\bar{P} = \frac{1}{2} |\widetilde{V}_T|^2 \frac{R_D}{(R_T + R_D)^2 + X_D^2}. \quad (1.36)$$

Prema teoriji [3], maksimalni prenos energije se dobija kada je impedansa plazme jednaka konjugovanoj vrednosti impedanse izvora. Ovu vrednost možemo da nađemo i iz uslova $\partial \bar{P} / \partial X_D = 0$ i $\partial \bar{P} / \partial R_D = 0$ koji će dati da je $X_D = 0$ i $R_D = R_T$ odnosno:

$$\bar{P}_{max} = \frac{1}{8} \frac{|\widetilde{V}_T|^2}{R_T}. \quad (1.37)$$

U standardnom režimu velikih snaga, u praksi, je u ovakvim kolima uvek $R_D < R_T$. Sa druge strane, za manje snage treba da važi $R_D > R_T$ pa se tada umesto L tipa češće koriste T i Π tipovi kola za prilagođenje koji su umesto dva sačinjeni od tri elementa. Kod njih je induktivni element najčešće fiksiran dok se kondenzatori promenljive kapacitivnosti koriste kako bi se postiglo maksimalno prilagođenje.

Ovakve, kapacitivno spregnute plazme se zavisno od frekvencije na kojoj se pražnjenje održava mogu podeliti na nisko i visoko frekventne. Osnovni kriterijum podele je mogućnost jona da prate promene spoljašnjeg polja i za nisko frekventne plazme može da se predstavi kao:

$$V_d^{ef} \frac{1}{2f} > d. \quad (1.38)$$

Ovde je sa V_d^{ef} obeležena efektivna brzina jona, sa f frekvencija a sa d rastojanje između elektroda. U ovom slučaju joni mogu da prate promenu polja, struja i napon su u fazi a priroda prielektrodne oblasti je rezistivna.

Primenjujući istu logiku, uslov za visoko frekventne plazme je:

$$V_d^{ef} \frac{1}{2f} \ll d. \quad (1.39)$$

U tom slučaju joni više ne mogu da prate promene spoljašnjeg polja, struja će prednjačiti za određen fazni pomak ispred napona a priroda prielektrodne oblasti je kapacitivna. Granica između ova dva tipa pražnjenja se nalazi na nekoliko MHz. Ovi režimi razlikuju se po preovlađujućim mehanizmima za jonizaciju ali i po naponu održavanja, što se može uočiti na slici 1.1.3 gde su minimalni radni naponi predstavljeni za širok opseg frekvencija pražnjenja na niskom pritisku.

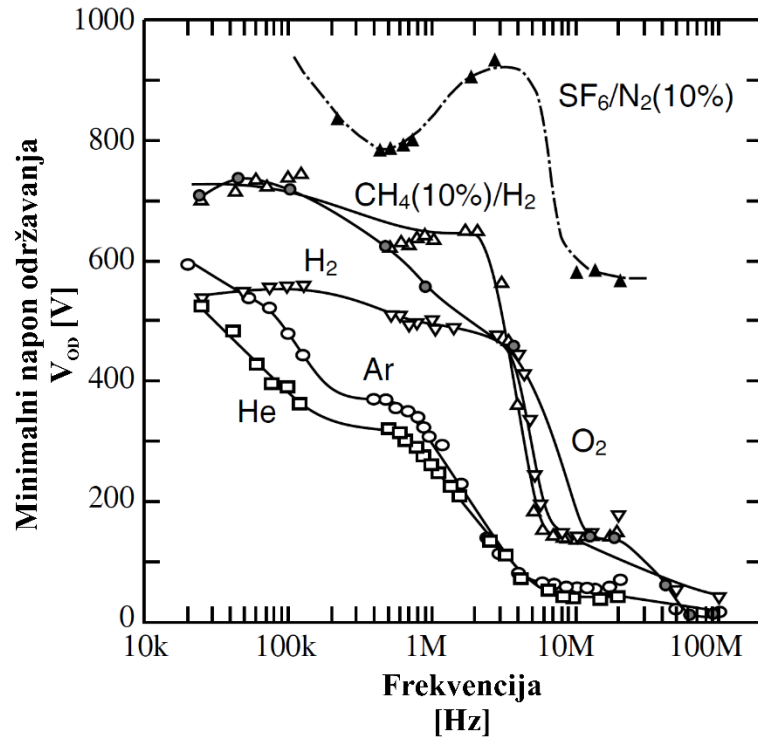

Slika 1.1.3 Minimalni napon održavanja kapacitivno spregnutog pražnjenja u zavisnosti od frekvencije $p=1\text{Torr}$, $d=2\text{cm}$ [3].

Kada se pražnjenje odvija na niskom pritisku i malim frekvencijama (otprilike ispod 100kHz), glavni mehanizam za održavanje pražnjenja je jonizacija elektronima visoke energije koje joni udarom izbijaju iz elektrode. Najintenzivniji fluks jona ka napajanoj elektrodi se događa kada je napon na minimumu, odnosno u slučaju sinusne pobude kada mu je faza $3\pi/2$. Kako bi se izbio dovoljan broj elektrona i kako bi oni imali dovoljno energije da daljim jonizacijama održavaju nisko-frekventno pražnjenje, u prielektrodnoj oblasti postoji jako električno polje i veliki pad napona. Imajući u vidu da je napajanje naizmenično jasno je da će se tokom jednog perioda napajanja ovakve, aktivne, prielektrodne oblasti razviti po jednom ispred svake elektrode. Po koeficijentu emisije sekundarnih elektrona, ovaj način održavanja pražnjenja se zove još i γ -mehanizam. Na slici 1.1.4 je pored odnosa struje, napona i snage (1.1.4 b) prikazano i u kojim će trenucima vremena i oblastima prostora dolaziti do ekscitacija (1.1.4 a).

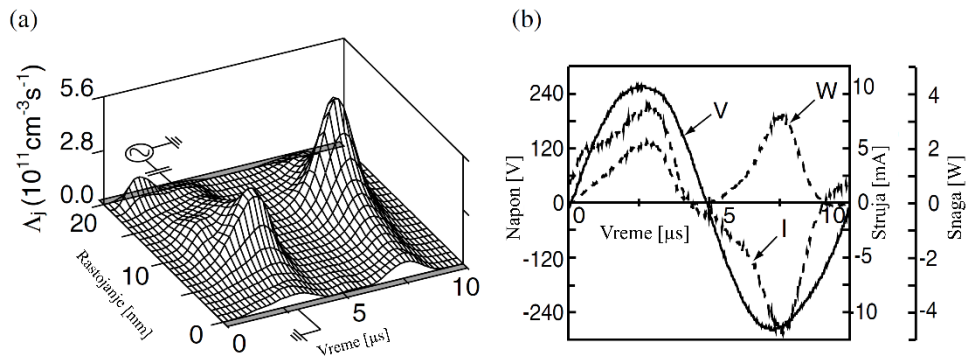

Slika 1.1.4 Nisko frekventno kapacitivno spregnuto pražnjenje na 100 kHz i 1 Torr u H_2 a) oblasti ekscitacija i b) vremenski promenljivi signali struje, napona i snage [3].

Struja u prielektrodnoj oblasti je sačinjena najvećim delom od kondukcione komponente a sa slike 1.1.4 se vidi da, za razliku od napona, nema sinusoidan oblik.

Tri važne osobine nisko frekventnih pražnjenja su:

- koncentracije naelektrisanih čestica u plazmi su male i prielektrodna oblast je široka
- do elektrode dolaze joni visoke energije
- napon održavanja je visok

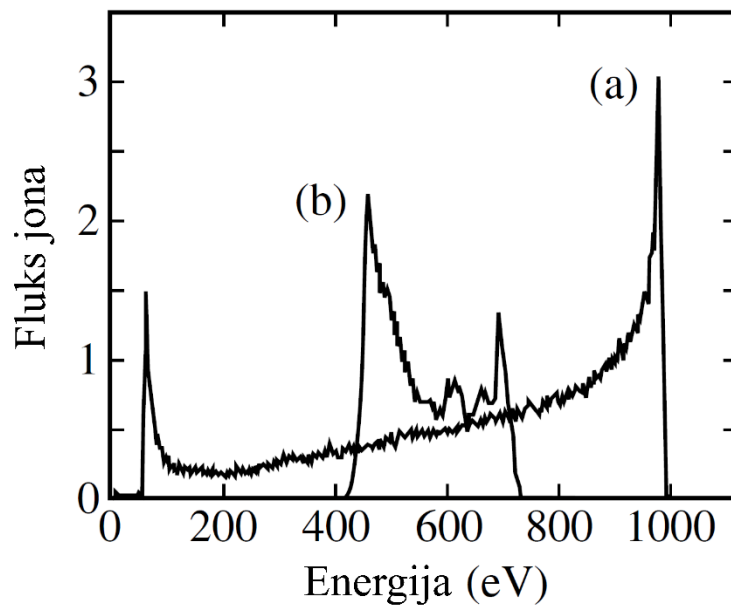

Slika 1.1.5 Bi-modalne distribucije jona po energijama u kapacitivno spregnutim pražnjenjima na niskom pritisku i a) niskoj i b) visokoj frekvenciji [3].

Raspodela jona po energijama u kapacitivnoj spregnutoj plazmi na niskom pritisku je takva da ima dva maksimuma koji će se sa povećanjem frekvencije približavati jedan drugom, kao što je prikazano na slici 1.1.5.

Sa porastom frekvencije napajanja, joni će sve manje biti u stanju da prate promene polja u vremenu i kada uđemo u oblast u kojoj nejednakost 1.39 počinje da važi plazma postaje visoko

frekventna. Struja sada prednjači u odnosu na napon (slika 1.1.6) a broj elektrona i jona koji dolaze do elektroda je značajno manji. Plazma će se održavati elektronima koji dolaze iz centralnog dela plazme a koji energiju dobijaju tako što se odbiju od granice prielektrodne oblasti, koja se takođe pomera. Najveći broj jonizacija biće izvršen upravo na granici između prielektrodne oblasti i centralnog dela neutralne plazme. S obzirom na to da se multiplikacija naelektrisanja događa u sudarnoj jonizaciji u centralnom delu zapremine, koja se opisuje koeficijentom α , za pražnjenja u ovom režimu kažemo da su u α -modu. Sa daljim povećanjem frekvencije i elektroni će sve slabije reagovati na promene spoljašnjeg polja, što će dovesti do smanjenja prielektrodne oblasti ali i pada napona potrebnog za održavanje pražnjenja.

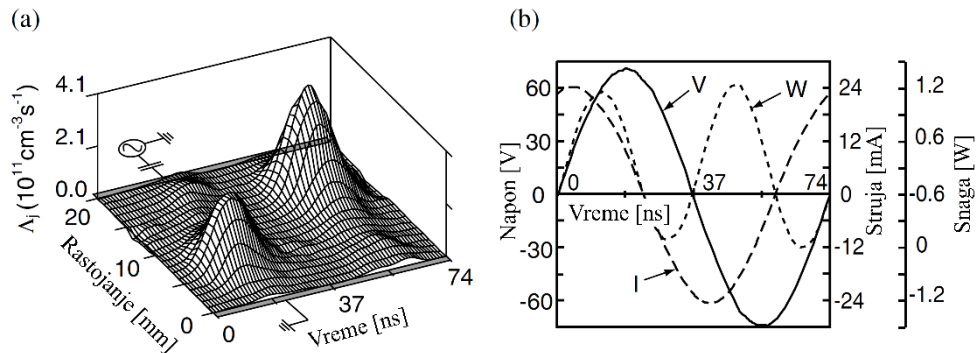

Slika 1.1.6 Visoko frekventno kapacitivno spregnuto pražnjenje na 13.56 MHz u H_2 a) oblasti ekscitacija i b) vremenski promenljivi signali struje, napona i snage [3]

Struja u prielektrodnoj oblasti visoko frekventnih kapacitivno spregnutih pražnjenja u najvećem delu je struja pomeraja a u ovom slučaju i struja i napon mogu da imaju pravilne sinusoidne oblike kao što je ilustrovano na slici 1.1.6.

Osnovne osobine visoko frekventnih pražnjenja su:

- plazma ima veliku koncentraciju i usku prielektrodnu oblast
- napon održavanja je nizak
- do elektrode dolaze joni male energije
- struja i napon imaju pravilan sinusoidalni oblik

Jonska i elektronska struja u blokirajućem kondenzatoru bi tokom celog perioda trebalo da su jednake, ali će se zbog veće pokretljivosti elektrona negativno naelektrisanje vrlo brzo nagomilati na oblogama kondenzatora. Da bi se sprečilo da se zbog ovoga u plazmi pojavi prednapon, odnosno da bi jednosmerna komponenta signala ostala na nuli, potrebno je da C_B bude na negativnom potencijalu.

Osim frekvencije napajanja, plazma sistem poseduje još nekoliko osobina koje zajedničkim imenom nazivamo spoljni parametri. To su karakteristike sistema koje mi biramo. Neki od najvažnijih su geometrija i dimenzija komore za pražnjenje, koncentracija neutrala, struja ili napon. Ono što se u plazmi fizici zove centralni problem je definisanje veze između pomenutih veličina i unutrašnjih parametara plazme u koje spadaju koncentracija naelektrisanih čestica, njihove temperature, trenutna i srednja debljina prielektrodne oblasti, realna snaga pražnjenja i slično. Imajući u vidu da relevantne čestice mogu da imaju vrlo složene prostorne i vremenske raspodele kao i distribucije po energijama koje često odstupaju od idealnih ili očekivanih, jasno je da nalaženje veze između spoljašnjih i unutrašnjih parametara plazme može da bude veoma komplikovano. Međutim, primenom homogenog modela [6] može da se dođe do nekih rešenja centralnog problema koja ne odstupaju mnogo od realnosti. Osnovne pretpostavke i pojednostavljenja ovog modela su:

- joni reaguju samo na vremenski usrednjene potencijale
- elektroni su nosioci struje pražnjenja i reaguju na trenutne potencijale
- $n_e=0$ u prielektrodnim oblastima
- na elektrodama ne dolazi do transverzalnih varijacija
- $n_i=const$ u svim oblastima pražnjenja

Uslovi za primenu ovih aproksimacija nisu toliko restriktivni i važe u velikoj većini visokofrekventnih pražnjenja plan paralelne geometrije na niskom pritisku.

Kako bi se dodatno olakšalo razumevanje pražnjenja i njegovih električnih osobina plazma se može predstaviti i preko šeme ekvivalentnog električnog kola. Jedan primer takvog kola je prikazan na slici 1.1.7.

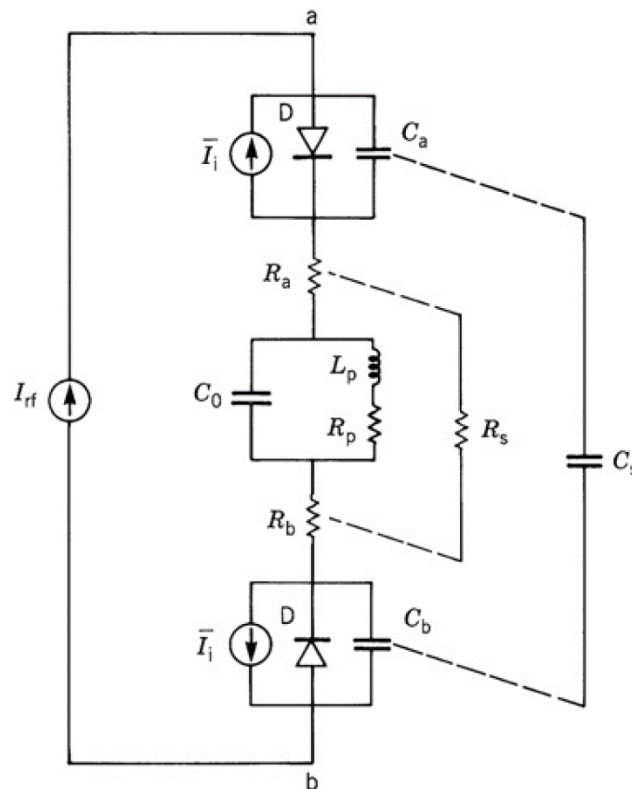

Slika 1.1.7 Model ekvivalentnog električnog kola kojim se opisuju nelinearne električne osobine homogenog radiofrekventnog pražnjenja [6]

Na ovoj šemi su indeksima a i b obeležene veličine vezane za jednu ili drugu elektrodu dok se indeks s odnosi na prielektrodne oblasti (od reči sheath). Tako da je sa C_s označena ukupna kapacitivnost prielektrodnih oblasti, dok su indeksima a i b označene kapacitivnosti za svaku elektrodu posebno. Struja jona je modelovana strujnim izvorima I_i jer po pretpostavkama homogenog modela ona stalno postoji, ali nije konstanta već zavisi od vrednosti V_{rf} . Sa druge strane da bi se modelovala struja elektrona treba uzeti u obzir da će ona postojati samo u onim trenucima kada centralni deo plazme, koji će se tokom jednog perioda pomeriti sa jedne na drugu stranu pražnjenja i nazad, dodirne elektrodu. Ovakvo ponašanje se najvernije opisuje diodom. Induktivna impedansa plazme je obično mala a treba imati u vidu da se skoro sve promene potencijala događaju u prostoru prielektrodnih oblasti.

Prateći šemu sa slike 1.1.7 i pretpostavke homogenog modela možemo da kažemo sledeće:

Uvod

$$d = l - 2\bar{s} = \text{const} \quad (1.40)$$

$$C_0 = \frac{\varepsilon_0 A}{d} \quad (1.41)$$

$$L_p = \frac{1}{\omega_{pe}^2 C_0}. \quad (1.42)$$

Ovde je sa A obeležena površina elektrode, ω_{pe} je plazmena frekvencija elektrona ($(\frac{ne^2}{\varepsilon_0 m})^{1/2}$), l je ukupno rastojanje između elektroda a \bar{s} je srednja dužina prielektrodne oblasti.

Unutar prielektrodne oblasti, odnosno kada važi $x \leq s(t)$, Poasonova jednačina dobija sledeći oblik:

$$\frac{dE}{dx} = \frac{en}{\varepsilon_0}; \quad (1.43)$$

odnosno

$$E(x, t) = \frac{en}{\varepsilon_0} [x - s(t)]. \quad (1.44)$$

Ako sada struju pomeraja predstavimo kao:

$$I(t) = \varepsilon_0 A \frac{\partial E}{\partial t} \quad (1.45)$$

i u nju ubacimo jednačinu 1.44, dobija se oblik koji povezuje dužinu prielektrodne oblasti i struju:

$$I(t) = -enA \frac{ds}{dt}. \quad (1.46)$$

Ukoliko se struja sada predstavi kao $I(t) = I_{rf}(t) = I_1 \cos \omega t$ i integrihali poslednja jednačina, dobija se konačni oblik jednačine za dužinu prielektrodne oblasti koji zavisi samo od spoljnih parametara:

$$s = \bar{s} - s_0 \sin \omega t, \quad s_0 = \frac{I_1}{en\omega A}. \quad (1.47)$$

Iz dobijenih jednačina, pad napona u prielektrodnoj oblasti možemo jednostavno dobiti kao:

$$V(t) = \int_0^{s_a} E dx = -\frac{en}{\varepsilon_0} \frac{s^2}{2}. \quad (1.48)$$

Vidimo da će zbog kvadrata sa desne strane ova funkcija imati nelinearan karakter. Međutim ako ukupan pad napona u oblasti ispred obe elektrode napišemo kao $V_{ab} = V_a - V_b$ može da se dobije oblik koji će biti linearan:

$$V_{ab} = \frac{2en\bar{s}s_0}{\varepsilon_0} \sin \omega t. \quad (1.49)$$

Ukupnu kapacitivnost obe prielektrodne oblasti, C_s , dobijamo tako što je izračunamo kao ekvivalentnu kapacitivnost dva kondenzatora koja su serijski povezana odnosno:

$$C_s = \frac{\varepsilon A}{2s_0}, \quad (1.50)$$

tako da važi:

$$I_{rf} = C_s \frac{dV_{ab}}{dt}. \quad (1.51)$$

Na slici 1.1.8 je prikazano kako, uz pretpostavke homogenog modela, izgledaju nelinearni naponi ispred svake od elektroda i kako će njihova ukupna vrednost imati pravilan sinusni oblik. Sa \bar{V} je obeležena srednja vrednost ispred jedne od elektroda.

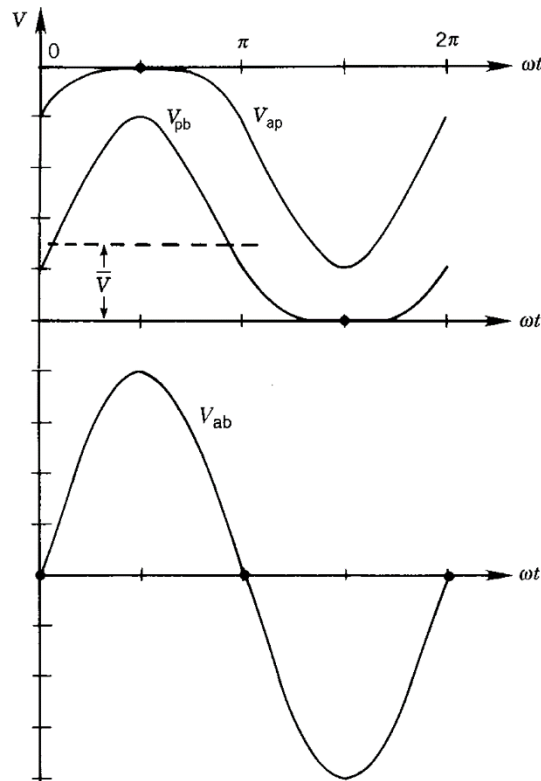

Slika 1.1.8 Nelinearni naponi u prielektrodnim oblastima a i b (gore) i njihova linearna razlika (dole) [6].

Najveći deo snage koja se pošalje plazmi će završiti kao toplota u nekom obliku. Koristeći postulate homogenog modela, moguće je proceniti snagu koja će se u toplotu pretvoriti mehanizmima omskog i stohastičkog grejanja.

Pod omskim grejanjem se podrazumeva energija koju oscilujući elektroni predaju neutralima u sudarima. Vremenski usrednjena vrednost ove veličine dobija se preko sledeće jednačine:

$$\bar{S}_{om} = \frac{1}{2} \frac{l_{rf}^2}{A^2} \frac{m v_m d}{e^2 n}. \quad (1.52)$$

Gde je v_m frekvencija sudara između elektrona i neutrala a n koncentracija naelektrisanih čestica.

Energiju koju će elektroni da prime u jedinici vremena od pokretne granice prielektrodne oblasti nazivamo stohastičkim grejanjem. Ukoliko početnu brzinu elektrona obeležimo sa u , brzinu reflektovanog elektrona sa u_r a brzinu pokretne granice sa u_p , dobićemo jednačinu sličnu kao i kada bi razmatrali udar lopte u pokretan zid:

$$u_r = -u + 2u_p. \quad (1.53)$$

Raspodelu elektrona po brzinama na granici možemo da napišemo kao $f(u,t)$, pa će onda broj onih koji u granicu udari u intervalu dt i opsegu brzina du biti $(u-u_p)f(u,t)dudt$. Odakle se dobija da će stohastičko grejanje biti[6]:

$$S_{stoh} = -2m \int_{u_p}^{\infty} u_p (u - u_p)^2 f(u, t) du. \quad (1.54)$$

Za slučaj uniformne raspodele će da važi:

$$\int_{-\infty}^{\infty} f(u, t) du = n = const. \quad (1.55)$$

Rešavanje ovog problema u realnim plazmama nije ni malo jednostavno jer se pored ostalih veličina i f menja sa vremenom, odnosno sa oscilovanjem granice. Međutim, ako pretpostavimo da je raspodela Maksvelova, odnosno da je nasumični fluks elektrona $\frac{1}{4} n \bar{v}_e$, ako brzinu granice možemo da napišemo kao $u_p = u_0 \cos \omega t$ i ako je struja u centralnom delu plazme u glavnom kondukciona, onda će se za jednu prielektrodnu oblast dobiti:

$$\bar{S}_{stoh} = \frac{1}{2} \frac{m \bar{v}_e I_1^2}{e^2 n A^2}. \quad (1.56)$$

Iako se stohastičko i omsko grejanje i dalje smatraju glavnim mehanizmima predaje energije elektronima, istraživanja ovog problema i dalje traju [11]. Prvu eksperimentalnu potvrdu postojanja stohastičkog mehanizma grejanja dali su Godyak i Popov [12] pokazavši da samo omskim grejanjem ne može da se objasni količina energije koju elektroni preuzimaju. Kasnije je pokazano da pretpostavka tvrdog zida može da se primeni na elektrone visoke energije ali da elektroni manje energije neće uvek da se odbiju od ovakve barijere [13]. Pored mehanizma vraćanja ka centralnom delu plazme, nezanemarljiv udeo u energetskom bilansu mogu da imaju i elektroni koje granica prielektrodne oblasti ubrzava ka zidu [14]. Takođe je pokazano da nelinearni efekti mogu da igraju veliku ulogu u sistemima koji nisu simetrični [15].

Eksperimentalna izučavanja električnih pražnjenja u gasovima su se kroz istoriju, pa i danas, obavljala na velikom broju različitih sistema. Oni se među sobom razlikuju po dimenzijama, obliku, električnim osobinama ili primenjenim dijagnostičkim metodama pa je postalo jasno da je eksperimente koji su rađeni na različitim aparaturama jako teško porediti. Zbog toga su napravljeni koraci sa ciljem standardizacije pre svega plazma reaktora koji se koriste u primenama. Pitanje standardizacije plazma reaktora je prvi put pokrenuto na konferenciji pod imenom Gaseous Electronics Conference u Mineapolisu (Minneapolis) 1988. godine [16]. Dogovoreno je da se razvije sistem koji bi mogao lako da se replicira, lako da se dijagnostikuje različitim metodama i koji bi bio tehnološki relevantan za primene. Dodatni uslov je bio da geometrija reaktora bude jednostavna koliko god je moguće kako bi se olakšalo modelovanje. Kao rezultat je nastala GEC referentna komora za radiofrekventna pražnjenja (*eng* GEC Reference Cell). Kako bi se proverilo da li je moguće dobiti reproducibilne rezultate ukoliko se merenja obavljaju na različitim reaktorima identičnih konstrukcija, odlučeno je da se ispituju električne karakteristike u pražnjenju u čistom argonu a merenja su uređena u 5 različitih laboratorija na 6 različitih komora [17]. Dobijeno je da se faza i amplituda osnovnog harmonika naponskog signala slažu sa greškom od oko 4%, dok je za osnovni harmonik strujnog signala slaganje bilo u okviru od 14%. Zaključak istraživanja je bio da iako postoji značajno slaganje u nekim parametrima plazme, na električne osobine ovakvih reaktora mnogo utiče i konstrukcija spoljnog električnog kola, odnosno parametri poput dužine kablova, konstrukcije kola za prilagođenje, izvora snage ali i pozicija mernih sondi. U jednoj od laboratorija je samo promena RF generatora izazvala promenu napona jednosmerne komponente za 30 do 50 %. Tokom vremena GEC komora je doživela nekoliko zvaničnih modifikacija u konstrukciji [16] a istraživanja i modelovanja na ovakvom sistemu i dalje traju. Konstrukcija jednog od reaktora koji je korišćen u eksperimentima tokom izrade ove disertacije inspirisan je upravo GEC komorom.

Kompletnosti radi, bez ulaženja u detalje, pomenućemo da se radi bolje kontrole kretanja jona i elektrona u pražnjenju često koriste i kapacitivno spregnuta pražnjenja koja se napajaju sa dve frekvencije. Oba izvora mogu da budu povezana na jednu elektrodu ili se zavisno od specifičnosti upotrebe mogu povezati na različite elektrode.

Još jedan specifičan tip plazme može da nastane kada se kao radni gas koriste gasovi koji imaju sklonost ka zahvatu elektrona. Za takve gasove i plazme kažemo da su elektronegativne. Zahvat elektrona odnosno stvaranje negativnog jona može da bude disocijativno i nedisocijativno a kada kao nosioce negativnog naelektrisanja imamo i jone, uslov kvazineutralnosti dobija malo drugačiji oblik:

$$n_p \sim n_e + n_n. \quad (1.57)$$

Ovde se indeks e odnosi na elektrone a indeksi p i n na pozitivne i negativne jone.

Elektronegativnost se definiše kao odnos koncentracija negativnih i pozitivnih jona:

$$H_{en} = \frac{n_n}{n_p}, \quad (1.58)$$

dok se potpuno negativnom plazmom smatra ona u kojoj važi da je $H_{en}=1$. Drugi koeficijent kojim se opisuju ovakve plazme je stepen jonizacije i on je definisan kao:

$$H_j = \frac{n_p}{N}, \quad (1.59)$$

gde je sa N obeležena koncentracija neutrala.

Za razliku od elektropozitivnih plazmi, o kojima je do sada bilo reči, u situaciji kada većinu naelektrisanja nose i pozitivni i negativni joni, dolazi do formiranja jakog polja u prielektrodnoj oblasti dok će i polje u centralnom delu pražnjenja biti intenzivnije. Posledica ovakve situacije je da će postojati tri specifične zone u kojima elektroni stvaraju aktivne čestice. U prvoj zoni se to dešava nakon što se reflektuju od granice prielektrodne oblasti u blizini trenutne katode. U drugoj će se to dešavati pod dejstvom jakog polja u centralnom delu plazme, dok u trećoj zoni to čine elektroni ubrzani dvostrukom prielektrodnom oblašću ispred trenutne anode. Grafički prikaz ovakve situacije za jedan ceo period je dat na slici 1.1.9.

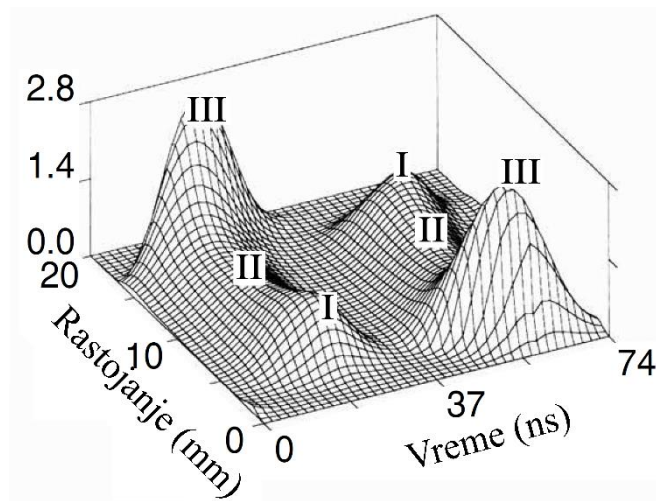

Slika 1.1.9 Tri zone ekscitacije u elektronegativnim plazmama elektronima koji su: I – reflektovani od trenutne katode, II – ubrzani poljem u centralnom delu plazme i III – reflektovani od dvostrukog sloja trenutne anode [3].

U elektronegativnim plazmama se smanjuje fazna razlika između struje i napona, odnosno sa povećanjem H_{en} njihova priroda prelazi iz kapacitivne u rezistivnu. Treba pomenuti i da verovatnoća za zahvat elektrona, odnosno nastajanje negativnih jona, raste sa povećanjem pritiska ali i u koliko se molekul ili atom ne nalazi u osnovnom već u nekom od pobuđenih stanja. Tipični gasovi u kojima

nastaju ovakve plazme su O_2 , SF_6 , Cl_2 , i CF_4 a na slici 1.1.10 je predstavljen izgled dvostruke prielektrodne oblasti ispred trenutne anode u ovakvim pražnjenjima.

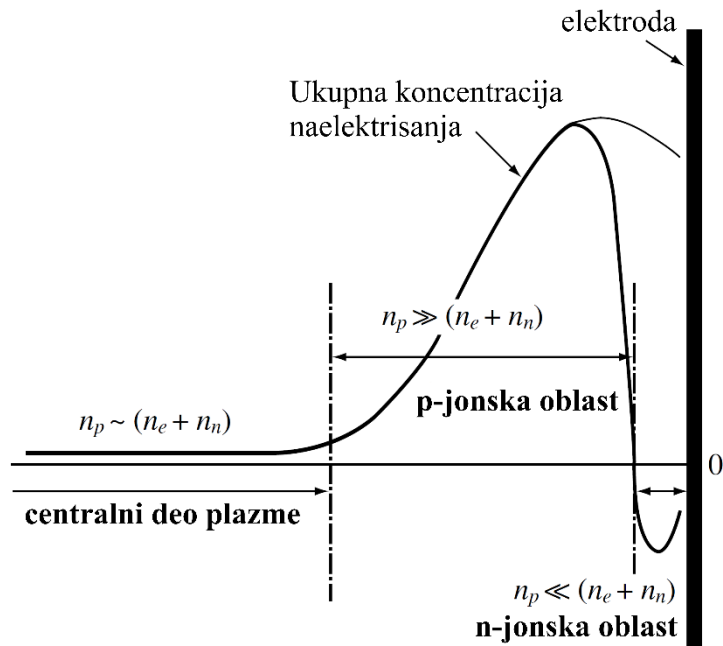

Slika 1.1.10 Dvostruka prielektrodna oblast elektronegativnih plazmi [3].

1.1.2 INDUKTIVNO SPREGNUTA PRAŽNJENJA

Do sada smo pričali o pražnjenjima kod kojih se, praktično gledano, plazma stvara između obloga kondenzatora, odnosno o kapacitivno spregnutim pražnjenjima. Međutim, postoji još jedan način konstrukcije reaktora u kome će plazma biti formirana i održavana električnim poljem zavojnice koja se nalazi oko komore za pražnjenje. Ovakve plazme nazivamo induktivno spregnutim (*eng* ICP – inductively coupled plasma) a dve moguće konstrukcije prikazane su na slici 1.1.11.

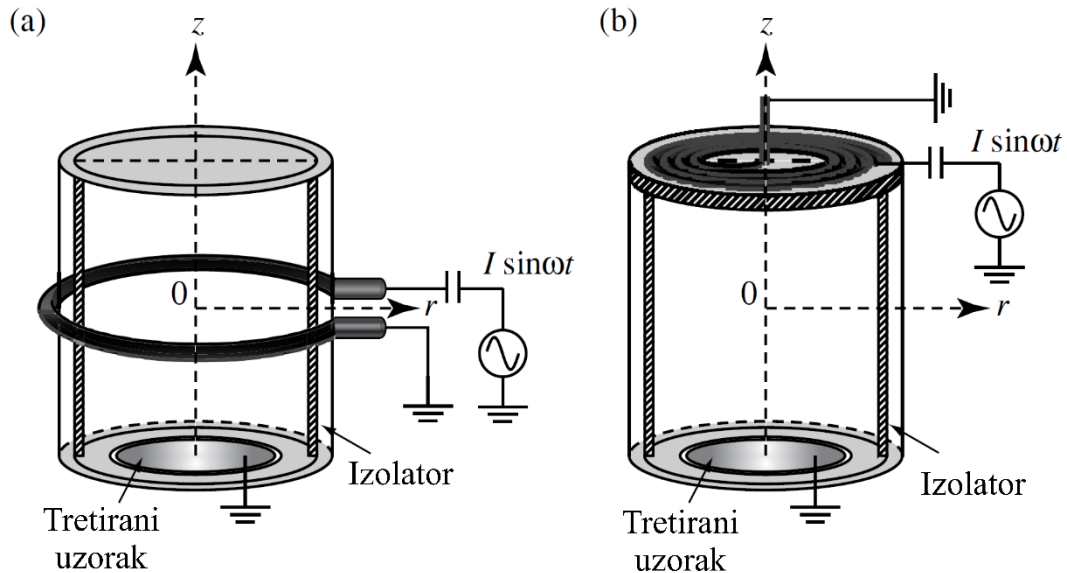

Slika 1.1.11 Primer reaktora za a) induktivno spregnute plazme (ICP) i b) transformatorski spregnute plazme [3].

Poseban slučaj induktivno spregnutih plazmi imamo kada se, kao na slici 1.1.11 b), zavojnica ne nalazi oko reaktora već sa jedne njegove strane i u tom slučaju govorimo o transformatorski spregnutoj plazmi (*eng* TCP – transformer coupled plasma).

S obzirom da ne postoje elektrode u klasičnom smislu te reči, ICP pražnjenja se nazivaju još i bezelektrodna. Proboj se obično događa preko kapacitivne sprege na kontaktima navoja. Režim slabe struje kroz navoj se zove E-režim dok će povećanjem snage, odnosno struje, plazma preći u H-režim kada sprega postaje čisto induktivna.

Prelaz između ova dva režima je jedna od najvažnijih osobenosti induktivnih plazmi. On se, povećanjem struje, obično događa naglo jer postoji granična, minimalna, vrednost struje u kome je održavanje H-režima moguće. Zanimljivo je da se smanjivanjem struje E-H prelaz neće dogoditi na istim parametrima pražnjenja, odnosno kažemo da je za ovaj prelaz karakteristično postojanje histerezisa. Na slici 1.1.12 je prikazana koncentracija pobuđenih atoma u pražnjenju u E (1.1.12 a)) i H-režimu (1.1.12 b)) [3].

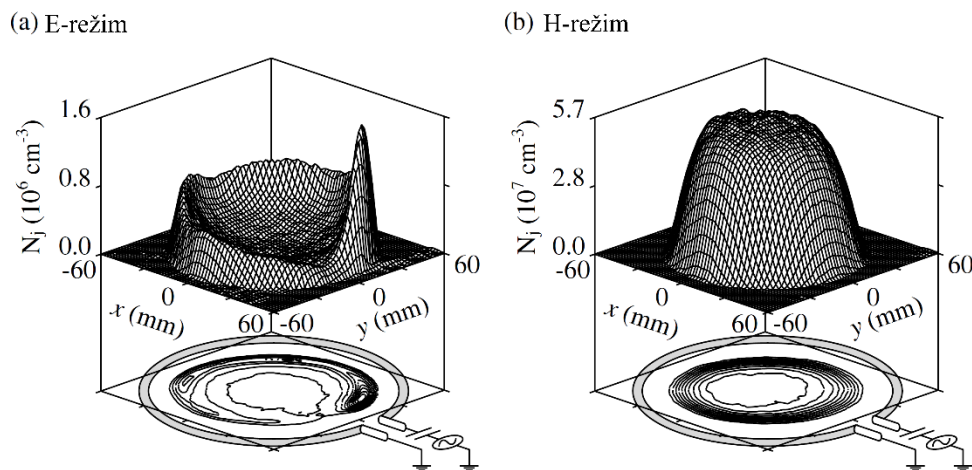

Slika 1.1.12 Koncentracija pobuđenih atoma u induktivno spregnutom pražnjenju u nivou kalema u a) E-režimu i b) H-režimu [3].

Za E-režim je karakteristično da je predaja snage slaba, da je koncentracija elektrona mala ali da je njihova srednja energija velika. Iako ne postoji elektroda koja je u dodiru sa plazmom, na mestu gde se snaga predaje, odnosno u blizini kontakata, se razvija svojevrsna prielektrodna oblast u kojoj postoji veliki pad napona što se vidi kao lokalni maksimum u koncentraciji pobuđenih čestica a predaja snage očigledno nije azimutalno uniformna. U H-režimu plazmi se predaje veći deo snage poslate iz izvora. Rezultujuća plazma ima znatno veće koncentracije ali manje prosečne energije elektrona. U oblasti gde se nalaze navoji, koncentracija naelektrisanih čestica je vrlo neuniformna pa se uzorak u ovakvom tipu plazme postavlja dalje od pobudnog kalema gde će plazma parametri imati manje radijalne oscilacije.

Glavni doprinos održavanja ICP plazmi u H-režimu daju elektroni. Oni će energiju dobijati od magnetnog polja koje postoji u sredini kalema (Amperov zakon) ali i od električnog polja koje se pojavljuje zbog promene fluksa magnetnog polja (Faradejev zakon) dok će u blizini zidova delovati i električno polje usled ambipolarne difuzije koje će sprečavati gubitak elektrona na njima.

1.2 DIJAGNOSTIKA RADIO-FREKVENTNIH PRAŽNENJA NA NISKOM PRITISKU

Kako bi se saznalo koji su fizički procesi koji stoje iza formiranja i rada plazme i na koji način se dobijaju primećeni efekti u pražnjenju postoje dva pristupa - kompjutersko modelovanje odnosno simulacija ili merenje odnosno dijagnostika. U mnogim slučajevima željenu veličinu vezanu za plazmu ne možemo direktno da izmerimo, poput recimo koncentracije neutralnih čestica, ali je moguće izmeriti neki od parametara, kao što je recimo optička emisija, koji su sa njom povezani na dobro definisani način. Generalno, dijagnostičke metode možemo da podelimo na one koje neće (znatno) perturbovati sistem – beskontaktno metode, kao što su pasivne optičke metode, i one koje svojim prisustvom utiču na samu plazmu, poput različitih sondnih merenja. Prednost beskontaktnih alata je jasna jer nema promena u pražnjenju. S druge strane, opseg veličina koje se ovako mere je vrlo ograničen i često se ovim metodama dobijaju prostorno usrednjene merene veličine za razliku od lokalnih metoda merenja koje nam mogu dati podatke o veličini u definisanoj tački zapremine sa plazmom. Zbog toga je najbolje, tamo gde je to moguće, primeniti veći broj dijagnostičkih pristupa, koji se često međusobno dopunjuju, kako bi dobili što kompletniju sliku o procesima u plazmi i što jasniju vezu između spoljnih i unutrašnjih parametara pražnjenja. U ovoj glavi će biti reči o principima rada svih dijagnostičkih metoda koje su primenjene tokom izrade ove disertacije.

1.2.1 MASENA SPEKTROMETRIJA

U svojoj osnovi, rad svih masenih spektrometara se bazira na dejstvu Lorencove sile. Odnosno, kada naelektrisana čestica uđe u prostor u kome postoji magnetno polje njena putanja će početi da se menja po zakonu:

$$\left(\frac{m}{q}\right) \mathbf{a} = \mathbf{E} + \mathbf{v} \times \mathbf{B}. \quad (1.60)$$

Ovde je sa m obeležena masa čestice a sa q njeno naelektrisanje. Ostale veličine su vektori i to \mathbf{a} ubrzanje, \mathbf{E} električno polje, \mathbf{v} brzina i \mathbf{B} magnetno polje.

Krajem 19.- veka je otkriveno da bi korišćenjem ukrštenog magnetnog i električnog polja nad česticama koje se kreću, ili njihovim snopovima, one mogle da se razvrstaju po odnosu mase i naelektrisanja. Engleski naučnik Tomson (Judith Jarvis Thomson), koji se smatra i začetnikom

masene spektrometrije, je iskoristio ovaj princip da 1897. godine otkrije do tada nepoznatu česticu vrlo velikog odnosa naelektrisanja prema masi. Tu česticu sada znamo kao elektron a za njegovo otkriće Tomson je dobio i Nobelovu nagradu [18]. Moderni maseni spektrometri, koji su analizirane čestice mogli da razvrstaju po odnosu m/Z , odnosno po odnosu mase i naelektrisanja, su nastali krajem druge decenije 20. veka. Tada su pored ukrštanja magnetnog i električnog polja počeli da ih koriste i u paralelnoj konfiguraciji a kao detektori su se pojavile fotografske ploče. Veliku primenu imali su i tokom drugog svetskog rata, najviše pri analizi izotopa, u istraživanjima vezanim za atomsko oružje.

Tokom mnogo decenija korišćenja maseni spektrometri su doživeli velike promene i unapređenja a današnji uređaji su, uglavnom, sačinjeni od: sistema za uzorkovanje, sistema za jonizaciju ukoliko je potreban, sistema za filtriranje po masama i/ili energijama, detektora i računara kao što je šematski prikazano na slici 1.2.1.

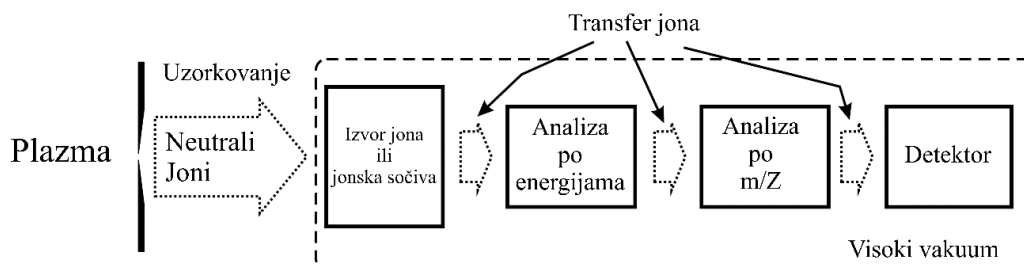

Slika 1.2.1 Šematski prikaz masenog spektrometra [19]

Masa merene čestice se u masenoj spektroskopiji izražava u jedinici koja se zove Dalton. Oznaka je DA a označava masu od $1/12$ ugljenikovog izotopa ^{12}C [20]. Prvi izazov ove dijagnostičke metode, koji je rešen još polovinom prošlog veka, je bio da se identifikuju izotopi jednog istog elementa. To je značilo da uređaji treba da budu dovoljno osetljivi da mogu da razlikuju mase koje su nekoliko redova veličine manje od jednog daltona. Sa druge strane, da bi ova tehnika mogla da se primeni u naukama kao što su farmacija, biologija ili medicina, trebalo je rešiti još jedan problem. U ovim disciplinama se pojavljuju molekuli čije su mase na drugoj strani spektra, odnosno izrazito velike. Ranim tehnikama jonizacije nije bilo moguće ukloniti elektron iz velikog molekula ili mu dodati proton a da taj proces ne dovede do njegovog cepanja na dva ili više delova. Takođe, ukoliko se veliki molekul samo jednom jonizuje može da bude problematično da on uspešno prođe put od sistema za uzorkovanje do detektora. Jedno od rešenja je da se veliki molekul višestruko jonizuje [21]. S obzirom da se u spektroskopiji rezultati predstavljaju kao odbroji u zavisnosti od odnosa m/Z [18], višestruko jonizovani molekuli bi se u takvom spektru pojavili na nekoliko mesta. Iako ovo deluje kao problem, ovi pikovi se mogu posmatrati kao ponovljena merenja čime se zapravo poboljšava ukupna preciznost. Razvijanjem takozvanih mekih metoda jonizacije (*eng* soft ionization), krajem osamdesetih godina prošlog veka, omogućeno je merenje velikih organskih molekula. Među najvažnijim koracima u tom smeru se smatra primena elektro spreja [22] u merenjima u biologiji i otkrivanje MALDI tehnike za jonizaciju [23]. Ovim je omogućeno da se svega nekoliko godina kasnije mere mase od više miliona daltona [24] a ubrzo nakon toga je izolovan i pojedinačni DNK molekul sa masom od preko 10^8 DA [25]. Danas postoji posebna oblast masene spektrometrije koja se bavi merenjima različitih proteina, ostalih velikih molekula pa čak i virusa i zove se proteomika (*eng* proteomics).

Dva važna parametra kojim se opisuje kvalitet samog uređaja i dobijenih spektara su masena rezolucija i tačnost mase [26]. Rezolucija predstavlja mogućnost spektrometra da razdvoji dva jona približnih masa odnosno približnog odnosa m/Z . Ukoliko je ova vrednost velika, pikovi u masenom

spektru će biti oštri i jasno razdvojeni. Numerička vrednost rezolucije može da se predstavi na dva načina. Prvi bi bio preko formule:

$$R = \frac{m}{\Delta m} \quad (1.61)$$

U jednačini 1.61 je m masa izmerenog jona a Δm je rastojanje do susednog jona. Ovo rastojanje se definiše kao udaljenje između dve bliske mase na kome signal padne na 10% od maksimalne vrednosti. U primeru koji je dat na slici 1.2.2 masu, odnosno m/Z , na vrednosti 1000 delimo sa rastojanjem od 0,208 čime se dobija rezolucija od 4800. Ukoliko ne postoji susedni jon, maksimum se deli sa punom širinom koju pik ima na 5% od maksimalne vrednosti. Važno je istaći da je u pitanju puna širina jer je slučaju preklapanja signala potrebno izvršiti njihovu dekonvoluciju. Ipak, najčešće korišćeni način predstavljanja je preko FWHM (*eng* Full Width at Half Maximum) vrednosti, odnosno tako što se maksimum intenziteta pika podeli sa punom širinom koju ima na 50% te vrednosti. U primeru sa slike će na ovaj način izračunat, isti spektar, imati rezoluciju od 10000. Jasno je da pri poređenju uređaja treba voditi računa da se koriste na isti način definisane vrednosti.

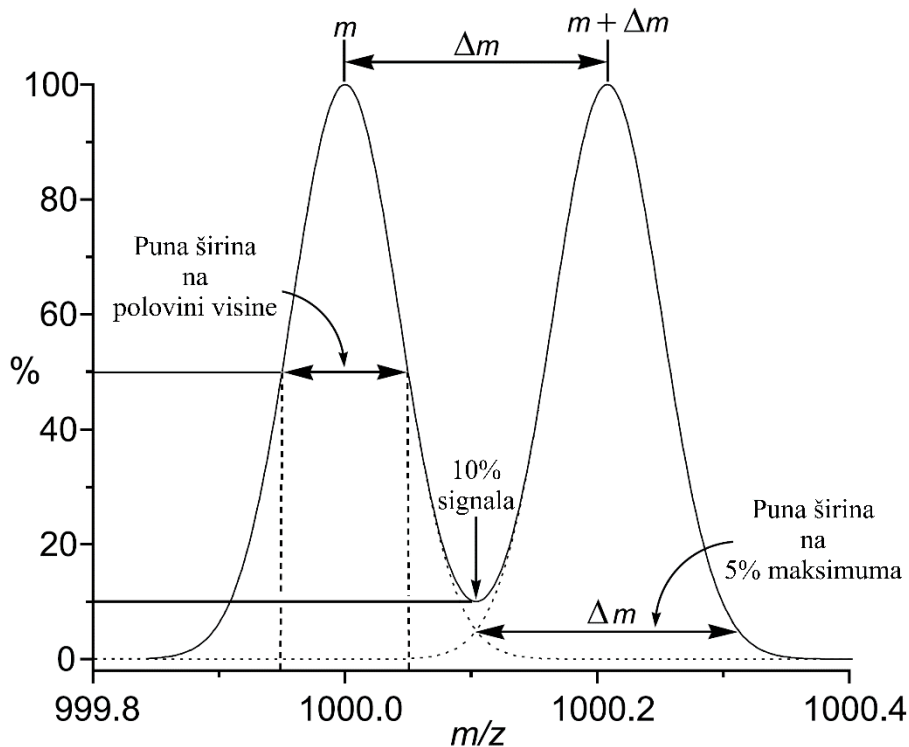

Slika 1.2.2 Primer dva susedna pika u masenom spektru sa naznačenim veličinama koje su potrebne za računanje rezolucije spektrometra [26].

Drugi parametar koji smo pomenuli, tačnost mase, nam govori o tome koliko se razlikuju izmerena i izračunata ili očekivana vrednost. Izražava se u ppm (*eng* parts per million):

$$\text{tačnost (ppm)} = 10^6 * \frac{m_{\text{izračunata}} - m_{\text{izmerena}}}{m_{\text{izmerena}}} \quad (1.62)$$

Kalibracija se vrši merenjem nekog poznatog jedinjenja a uređaji visoke rezolucije lako mogu da imaju tačnost koja je bolja 5 ppm. Ukoliko je tačnost mala, pik će da bude širok. Primer izmerenih profila za jednu istu masu a sa različitom tačnošću je dat na slici 1.2.3. U ekstremnim slučajevima, zbog previše širokog vrha, može da bude teško da se identifikuje tačna vrednost mase na kojoj se

nalazi izmerena čestica. Dodatni problem, koji se u današnje vreme ređe javlja, nastaje kada korak digitalizacije signala nije dobar. Jasno je da je poželjno da postoji što je moguće veći broj tačaka.

Zavisno od primene kojoj su namenjeni, postoji veliki broj mogućih konstrukcija masenog spektrometra. Ono po čemu se najviše razlikuju su načini jonizacije i principi po kojem se joni razdvajaju u zavisnosti od toga koliki im je m/Z . Objasnićemo ukratko najvažnije među njima a počecemo od tehnika za jonizaciju.

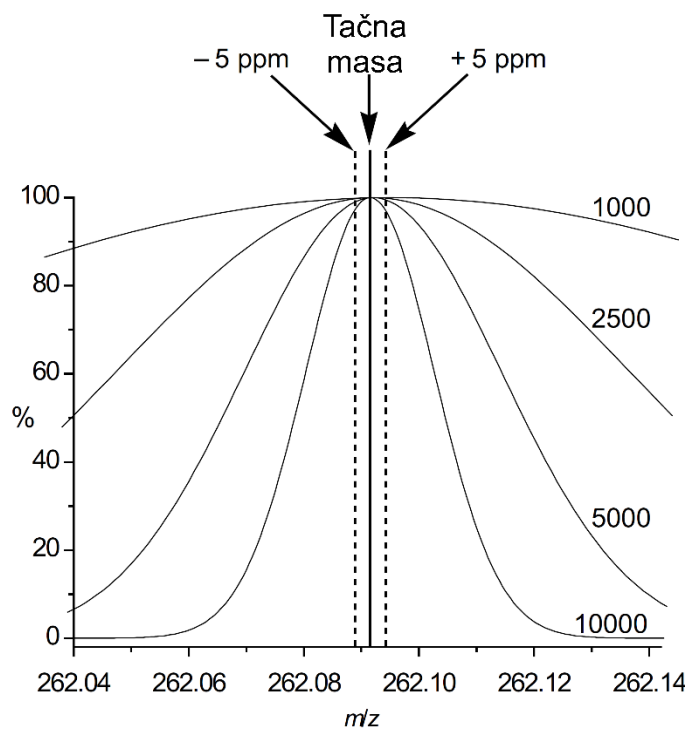

Slika 1.2.3 Primeri oblika profila na jednoj vrednosti m/Z sa tačnostima od 1000 do 10000. Isprekidana linija odgovara tačnosti od 5 ppm [26].

Jedan od najstarijih načina da se jonizuje neutral pre ulaska u maseni spektrometar je u sudaru sa elektronom visoke energije. Ovo je ujedno i jedna od najkorišćenijih metoda a maseno-energijski analizator koji je upotrebljen u izradi ove disertacije služi se upravo ovakvim tipom jonizatora. Uzorak koji se analizira mora da bude u gasnom stanju. Jonizujućim elektronima se emituju sa užarene žice, termoemisijom, a potom pod dejstvom električnog polja prolaze kroz prostor ispunjen ispitivanim gasom. Energija elektrona se bira podešavanjem napona ali je najčešće korišćena vrednost 70 eV. Ovakav jonizator se u glavnom koristi za jedinjenja čija je masa manja od 1000 daltona. U organskoj hemiji se često događa da se veliki molekuli nakon udara elektrona podele na više jona ili na jon i neutral, koji se neće videti u masenom spektru. S obzirom da je za mnoga jedinjenja poznat obrazac fragmentacije i da ona može da pruži informacije o strukturi polaznog molekula, u organskoj hemiji je fragmentacija čak i poželjna.

U slučaju da je poželjno sačuvati ispitivanu supstancu od fragmentacije, moguće je upotrebiti drugačiju metodu jonizacije – tzv. hemijsku jonizaciju. Na sličan način kao u prethodnoj metodi se jonizuje neki laki molekul poput CH_4 ili H_2O . Nakon jonizacije gas ulazi u oblast nešto većeg pritiska gde su sudari verovatniji. U tim sudarima nastaje protonizovani jon koji će imati jedan vodonik „viška“ kao na primer CH_5^+ ili H_3O^+ . Ukoliko se sad u zapreminu uvede neki molekul M koji ispitujemo, u sudarima može da dođe do transfera H^+ jona, odnosno protona po čemu se ovakva reakcija nekad naziva i PTR (*eng* Proton Transfer Reaction), pa će da nastane MH^+ jon ili

pseudomolekularni jon [26]. On se zatim pod dejstvom jednosmernog napona vodi ka detektoru. U novijim izvedbama, radi poboljšanja osetljivosti, se pored jednosmernog koristi i RF napon [27]. Iako ne dovodi do fragmentacije, i ova metoda jonizacije se koristi za merenja molekula ne mnogo većih od 1000 daltona.

Tehnika koja je bila popularna 1970-tih godina a koja takođe ne dovodi do fragmentacija velikih molekula je jonizacija poljem. Princip rada je takav da se ispred ulaza u detektor, prostor u kome se nalazi ispitivani gas, nalazi jedna ili više jako oštih igala. Razlika potencijala između te igle i ulaza u detektor je reda veličine 10000 V, a igla je na pozitivnom naponu. Zbog toga što je vrh špicast nastaje veliki gradijent polja, i do 10^{10} V/m, koji će izobličiti orbitale elektrona i efektom kvantnog tunelovanja privući elektron. Jon koji nastaje će pod dejstvom istog polja, će biti odgurnut ka ulazu u detektor. Ukoliko uzorak nije u gasovitom stanju, može da se nanese na iglu koja će se pored primenjenog napona i zagrejati kako bi dovela do isparavanja ispitivane supstance. Masa ispitivanih molekula obično ne prelazi 3000 daltona a najčešće je manja od 1000.

Jonizacija bombardovanjem brzim jonima ili neutralima se svodi na to da se ove čestice sa energijama od reda 10 keV usmeravaju ka rastvoru uzorka i takozvane matrice. Kada one dođu do površine, najveći deo kinetičke energije se potroši na udarni talas kroz rastvor ali će jedan njen deo moći da se iskoristi da izbacijon ispitivane supstance. Materija u kojoj je uzorak rastvoren treba da bude otporna na isparavanje, da ima malu viskoznost, da bude hemijski inertna, da može da rastvori uzorak i da pomaže jonizaciji. Ovaj metod je pogodan za uzorke čija je masa između 200 i 2000. Mogu se ispitivati i veći uzorci ali će u spektru postojati veliki šum.

Jedna od najpopularnijih i najkorisnijih tehnika za jonizaciju velikih molekula je jonizacija laserskom desorpcijom odnosno LDI (*eng* Laser Desorption Ionisation). Međutim, najveću primenu je postigla tek nakon razvoja laserske desorpcije uz pomoć matrica odnosno MALDI (*eng* Matrix Assisted Laser Desorption Ionisation). Suština ove tehnike je da se kratkim laserskim impulsom površini uzorka preda jako velika količina energije. To dovodi do isparavanja molekula sa njegove površine, ali zbog kratkog vremena delovanja, ne dolazi do reakcija u kojima veliki molekuli mogu da se podele. Kod MALDI tehnike je uzorak čvrst a ispitivani materijal se kristališe zajedno sa materijalom matrice. Nakon izlaganja laserskom pulsu ispareni materijal se širi nadzvučnom brzinom i pretpostavlja se da do jonizacije dolazi upravo u ovoj fazi, u reakcijama između ispitivanih molekula i pobuđenih ili jonizovanih čestica matrice. Princip rada je ilustrovan na slici 1.2.4. Iako je ovu tehniku jonizacije molekula sa masama i do 100.000 prvi upotrebio Tanaka [28] njenoj popularizaciji su doprineli radovi Karasa i Hilenkampa od kojih je prvi izašao iste godine [23] kad je Tanaka predložio upotrebu matrica. Ova tehnika se danas koristi za ispitivanje molekula sa masama znatno većim od milion daltona ali zbog postojanja višestruko jonizovanih vrsta spektar može da bude komplikovan.

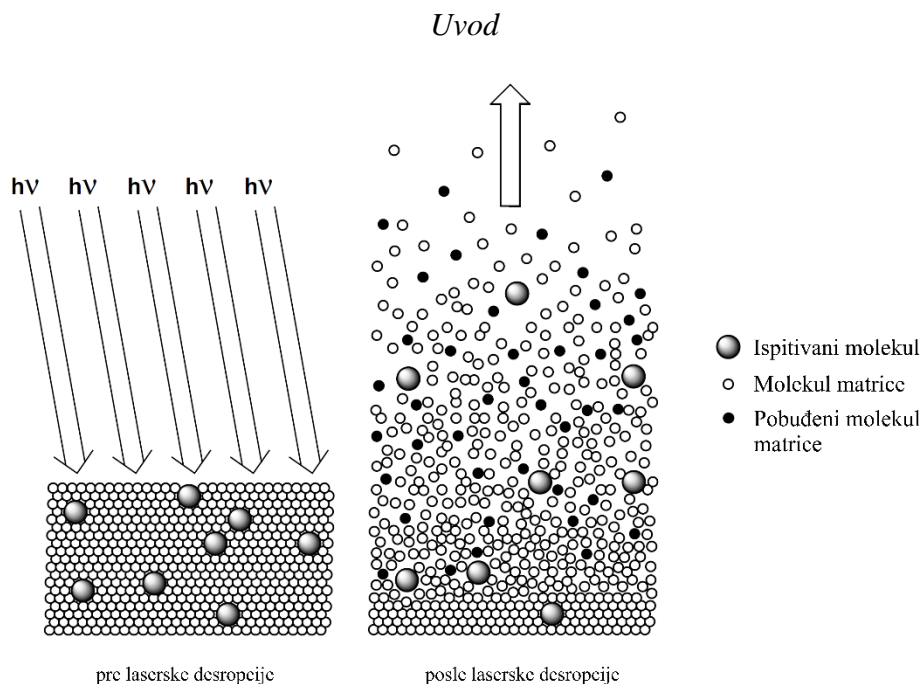

Slika 1.2.4 MALDI jonizacija – sa čvrstog uzorka se laserskim impulsom izbijaju ispitivani molekuli i matrica, jonizuju se tokom faze širenja [26].

Postoje primene masene spektrometrije u kojima nije potrebno analizirati velike molekule niti je bitna njihova struktura. Ukoliko je dovoljno da se sazna iz kojih je elemenata sačinjen uzorak, za jonizaciju može da se koristi i induktivno spregnuta plazma. Plazma se pravi obično u argonu a ispitivani materijal može da se ubaci direktno u pražnjenje ukoliko je gasnom stanju. Ukoliko je uzorak čvrst ili tečan može se ispariti laserskom ablacijom ili se radni gas (argon) propušta kroz uzorak ili preko njega.

Poslednja metoda jonizacije koju ćemo pomenuti, a kojom je moguće analizirati velike molekule, je jonizacija elektro-sprejom ili ESI (*eng* Electro Spray Ionisation). Ova tehnika je otkrivena 1960-tih ali je u masenoj spektrometriji prvi put upotrebljena tek sredinom osamdesetih [26], [29]. Da bi se formirali joni, rastvor ispitivane supstance se na pritisku koji može da bude i veći od atmosferskog propušta kroz kapilaru koja se nalazi na visokom naponu. Zavisno od potrebe, napon može da bude i pozitivan i negativan, obično je reda nekoliko kV a unutrašnji prečnik kapilare je manji od 250 μm [21]. Nakon prolaska kroz raspršivač nastaju kapljice rastvora jakog naelektrisanja. One se zatim izlažu struji vrućeg neutralnog gasa, najčešće azota, koji će isparavanjem gasa iz kapljice dovesti do njenog smanjivanja. U trenutku kada sila kojom se odbijaju joni ispitivane supstance nadjača površinski napon dolazi do takozvane Kulonove eksplozije, odnosno do pucanja kapljice na više manjih. Ovaj proces može da se ponavlja dok ne ostanu pojedinačni joni. Pomenuti postupak izaziva vrlo malo ili nimalo fragmentacija. S obzirom da se detekcija obavlja na malim pritiscima a raspršivanje na velikim, između detektora i raspršivača se pritisak obično obara višestepenim pumpanjem. Ovom metodom je moguće analizirati vrlo velike molekule ali je odnos mase i naelektrisanja često ispod 2000.

Sve metode za razdvajanje dobijenih jona po odnosu mase i naelektrisanja koriste električno polje, magnetno polje ili njihovu kombinaciju. Jedna od najpoznatijih metoda da se ovo postigne je upotrebom takozvanih sektora. Maseni spektrometri koji koriste ovu metodu su obično sačinjeni od elektrostatičkog analizatora i magnetnog sektora. Nakon što prođu jonizator i nakon što se ubrzaju određenim naponom, joni će prvo da naiđu na elektrostatički analizator. On je sačinjen od dve glatke zakrivljene metalne ploče među kojima je napon koji se može podešavati i time menjati električno polje. Pod dejstvom napona putanja jona će da se zakrivi za određen ugao. U ovom delu se praktično vrši odabir jona po energijama jer će na isto mesto na izlaznom otvoru da dođu joni koji imaju iste

kinetičke energije bez obzira na svoju masu. Ti joni zatim ulaze u magnetni sektor gde u smeru koji je normalan na njihovo kretanje deluje magnetno polje. Pod njegovim dejstvom će se putanje kriviti i to tako što će pod većim uglom skrenuti čestice manje mase. Na ovaj način se vrši selekcija jona po masama. Pažljivim odabirom ubrzavajućeg napona, električnog i magnetnog polja može da se postigne visoka rezolucija i široki opseg masa koje je moguće analizirati.

Jedan od najčešće korišćenih sistema za razdvajanje po masama koristi kvadrupole. Ovoj grupi maseno-energijskih analizatora pripada i uređaj koji korišćen tokom izrade ove disertacije. U njima se, nakon što prođu jonizator, joni usmeravaju u prostor u kome se nalaze četiri metalne šipke a koje su postavljene tako da su im duže ose paralelne sa početnom brzinom čestica. U idealnom slučaju bi njihov poprečni presek trebalo da je hiperboličan ali je u praksi on obično cilindričan. Naspramne šipke se nalaze na istom naponu, dok će druge dve biti na naponu suprotnog znaka. Na ovaj jednosmerni napon je superponiran i radiofrekventni potencijal. Pozitivan jon koji se nađe u ovom prostoru će biti privučen ka elektrodi koja se trenutno nalazi na negativnom naponu a biće odbijen od trenutno pozitivne elektrode. S obzirom da se polaritet elektroda menja, pod dejstvom ovakvog polja nastaje komplikovana trajektorija koja će biti stabilna samo za jone specifičnog m/Z odnosa. U specifičnim situacijama se može koristiti 6 ili čak 8 šipki, ali se u tom slučaju onda ne vrši selekcija po masama već se vrši sužavanje snopa jona što može da bude vrlo korisno ako se uzorkovanje vrši na visokom pritisku. Primer kvadrupolne konstrukcije je dat na slici 1.2.5.

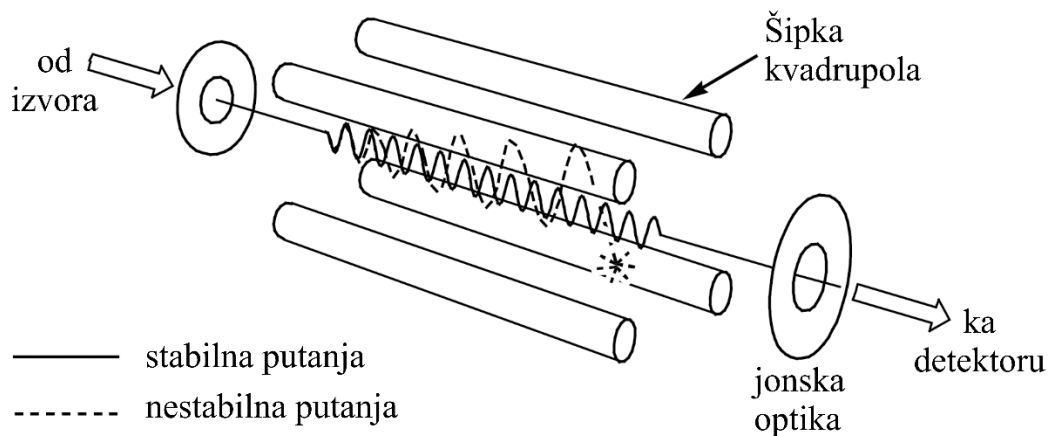

Slika 1.2.5 Primer stabilne i nestabilne putanje jona kroz kvadrupolni analizator [26].

Nobelova nagrada za fiziku je dodeljena za otkriće kvadrupolne jonske zamke koja se skraćeno obeležava sa QIT (*eng* Quadrupole Ion Trap). Konstruisana je u obliku prstena kome se sa donje i gornje strane nalaze dve ispušćene elektrode. Kroz jednu od njih joni ulaze a kroz drugu izlaze. Prostor je ispunjen helijumom na niskom pritisku čija je svrha da u sudarima sa jonima oduzima energiju kako bi ih usporio. Električno polje je takvo da sila koja deluje na jone direktno zavisi od toga koliko je on udaljen od centralne tačke u prostoru. Obično je zarobljen mali broj jona, nekoliko stotina, kako se ne bi međusobno odbijali i time uticali jedni drugima na stabilnost putanje. Da bi joni bili poslani dalje ka detektoru, polje može da se menja tako da prođu samo oni joni koji imaju željeni m/Z . Preciznost može da se poveća tako što se produži vreme tokom kog će joni biti zarobljeni jer će im se na taj način izjednačiti energije.

Najjednostavniji metod selekcije po odnosu m/Z je po vremenu preleta koji se koristi u takozvanim TOF analizatorima (*eng* Time Of Flight). Kod ovakvog analizatora je neophodno da se jonizacija odvija impulsno, najčešće primenom lasera, kako bi svi joni nastali istovremeno. Njima se

zatim pod dejstvom polja predaje kinetička energija i usmeravaju se ka cevi u kojoj ne deluje nikakvo polje i u kojoj je pritisak dovoljno mali da ne dolazi do međusobnih sudara. S obzirom da su svi joni ubrzani istom naponom i da su nastali na praktično istom mestu oni će imati identičnu kinetičku energiju. Vreme preleta kroz cev analizatora (*eng* drift tube) će onda da zavisi samo od mase, odnosno brži će biti lakši joni. S obzirom da je dužina cevi fiksna i obično je oko 1 m, i da će joni iste mase do detektora stići u istom trenutku moguće je samo merenjem vremena preleta dobiti m/Z :

$$zeV = \frac{1}{2}mv^2 \quad (1.63)$$

$$\frac{m}{z} = 2eV/\sqrt{v}. \quad (1.64)$$

Iako je princip rada ovakvih analizatora jednostavan, zbog zahteva da pritisak u cevi bude mali njihova cena je obično visoka. Masovniju upotrebu su doživeli tek krajem prošlog veka kada je elektronika postala dovoljno brza tako da je omogućavala precizno merenje vremena preleta. Mane u preciznosti zbog razlika u dužini puta i početne kinetičke energije jona mogu biti uklonjene upotrebom dodatne jonske optike odnosno reflektora. Osnovni princip rada TOF analizatora je ilustrovan na slici 1.2.6.

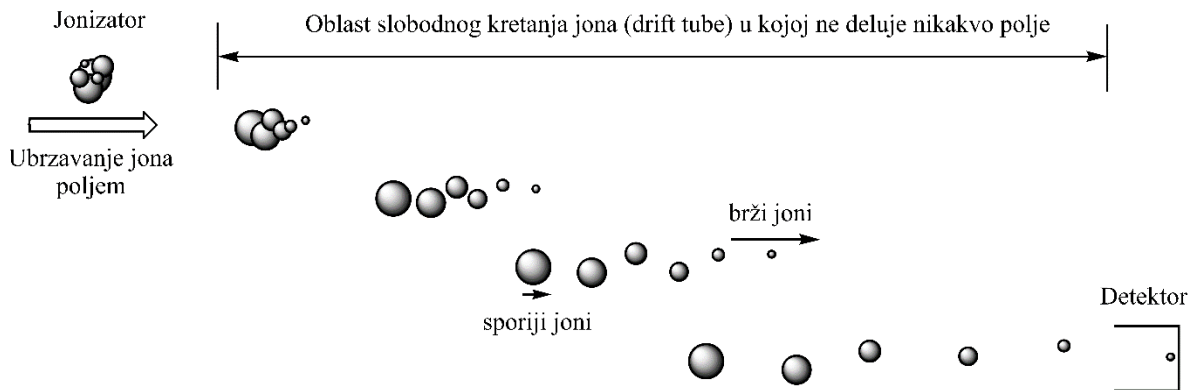

Slika 1.2.6 Princip rada TOF analizatora po masama [26].

Najpreciznija vrsta analizatora po masama, FTICR, koristi princip Furijeove transformacije jonske ciklotronske frekvencije (*eng* Fourier Transform Ion Cyclotron Resonance). Poput sektorskih analizatora i kod njih se koristi princip zakretanja putanje naelektrisane čestice u magnetnom polju. Ukoliko je polje dovoljno jako putanja jona će postati potpuno kružna. U tom trenutku su centripetalna sila (mv^2/r) i Lorencova (qvB) sila izjednačene pa može da se dobije da važi uslov:

$$\frac{qB}{m} = \frac{v}{r} = \omega. \quad (1.65)$$

Vidi se da, pri fiksnom magnetnom polju, odnos naelektrisanja i mase direktno zavisi od ugaone frekvencije kretanja jona a ne zavisi od linearne komponente njegove brzine. Upravo zbog ove osobine će FTICR uređaji imati veliku preciznost i malo širenje pikova u masenom spektru. Ugaona brzina kretanja naelektrisane čestice u magnetnom polju se naziva još i ciklotronska frekvencija, odakle je ova metoda dobila ime, a merenjem ove veličine možemo direktno da dobijemo m/Z . Joni koji su se našli u analizatoru će u početnom trenutku imati male radijuse putanja. Da bi se oni pobudili, odnosno da bi se ti radijusi povećali, prostor unutar analizatora se izlaže delovanju radiofrekventnog polja koje će za kratko vreme preći preko velikog opsega frekvencija. Na bočnim stranama analizatora, jedna preko puta druge, se nalaze prijemne ploče. Prilaženjem jednoj od njih, jon će da privuče određen broj elektrona. Delovanjem magnetnog polja on nastavlja kretanje i prići

će drugoj prijemnoj ploči gde izaziva istu reakciju. U ovim interakcijama joni polako gube energiju a na pločama se indukuje sinusoidna struja. Pojačavanjem ovog signala se dobija komplikovana struja u vremenskom domenu u kome će biti superponirani signali na frekvencijama svih jona unutar analizatora. Furijeovom transformacijom ovog signala se lako i brzo i dobija spektar jona u zavisnosti od m/Z . Iako ovakvi uređaji daju masene spektre izuzetno velike tačnosti i rezolucije zbog uslova jako malog pritiska, kako ne bi dolazilo do sudara između čestica, i korišćenja super-provodnih materijala njihova cena je velika i to sprečava masovnije upotrebu. Princip rada je ilustrovan na slici 1.2.7.

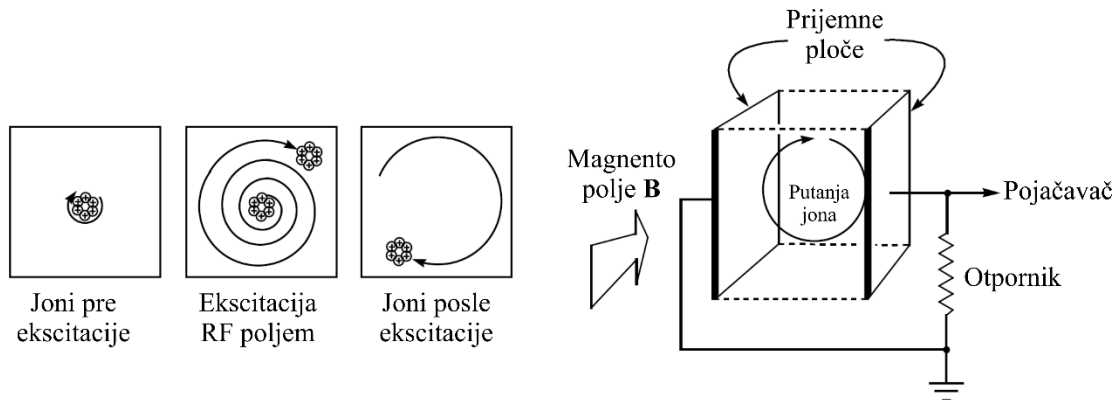

Slika 1.2.7 Princip rada FTICR analizatora. Pobuda jona elektronima (levo) i merenje strujnog signala (desno) [26].

Poslednji korak analize masenog spektra je detekcija. U idealnom slučaju odziv detektora bi trebalo da linerano zavisi od broja jona. Najstariji primerici su bili sačinjeni od fotografskih ploča ili foto-papira. Joni određenog odnosa m/Z , kod ove vrste detektora, nakon što prođu kroz jonizator i selektor po masama, padaju na unapred kalibrisano mesto na ploči ili papiru čime se praktično istovremeno meri ceo spektar. Većina detektora koji se danas koriste rade na principu multiplikacije elektrona. Po svojoj konstrukciji se razlikuju samo u prvom koraku multiplikacije. Jon ili grupa njih, koji dođe do detektora može da padne na površinu, na kojoj ovom prilikom nastaje foton usmeren ka fotomultiplikatoru ili može da izbije nekoliko elektrona. Dolaskom fotona do fotomultiplikatora, takođe nastaju elektroni. Dalji proces detekcije je praktično identičan. Ova negativno naelektrisana čestica se velikom razlikom napona ubrzava ka sledećoj pozitivno naelektrisanjoj elektrodi gde će dobiti dovoljnu kinetičku energiju kako bi i ona izazvala emisiju nekog broja elektrona. Kaskadnim ponavljanjem ovog procesa, praktično geometrijskom progresijom, se na kraju dobija impuls koji je pojačan i 10^8 puta. U poslednjoj etapi se vrši digitalna konverzija signala koji se obrađuje računom. Korišćenjem većeg broja ovakvih detektora moguće je da se dobije prostorna raspodela jona ili se proces merenja može paralelizovati. U našem sistemu je korišćen SEM (Secondary Electron Multiplier) detektor u kome udar jona direktno emituje sekundarne elektrone.

Pored dobijanja spektra u zavisnosti od m/Z odnosa, koji nam govori o prisustvu određenih vrsta i njihovom relativnom doprinosu u masenom spektru, maseni spektrometri mogu da se primene u tehnici merenja koja se zove masena spektrometrija praga za jonizaciju ili TIMS (*eng* Threshold Ionization Mass Spectrometry) kojom se razumevanje procesa u plazmi može značajno produbiti. Ona se bazira na činjenici da različite vrste, čak iako imaju iste mase ili isto m/Z , imaju različite pragove za jonizaciju. Ova tehnika primenjuje se isključivo nad neutralnim vrstama a merenja se obavljaju tako što se fiksira odnos m/Z koji se analizira a postepeno se povećava energija jonizujućih elektrona. Početak primene ove metode vezuje se za istraživanja Fonera i Hadsona (S. N. Foner, R. L. Hudson) koji su je primenili kako bi detektovali prisustvo metastabilnih pobuđenih stanja azota u post-pražnjenju (*eng* afterglow) [30]. Osnovna informacija koja može da se dobije ovom metodom,

pogotovo ako je kontrola energije elektrona precizna, je upravo energija jonizacije određene vrste [31], [32] ali se ona ipak i dalje najviše koristi kako bi se analizirali pobuđeni atomi i molekuli u pražnjenju [33]. Posebno je interesantno da se, uz određenu kalibraciju i pripremu eksperimenta, mogu meriti i apsolutne koncentracije [34]. One se mogu dobiti za sve neutralne čestice koje odgovaraju konkretnom odnosu m/Z [34]–[37] a može se dobiti i apsolutna koncentracija pobuđenih čestica [33]. Ova tehnika se može koristiti i za potvrdu postojanja određenih reakcija [38] a zanimljive su i primene kojima se u fuzionim reaktorima dobija odnos različitih izotopa ili se razdvajaju vrste istog m/Z [39]. Istovremenom upotrebom dva spektrometra i primenom TIMS-a moguće je odrediti i gubitak pobuđenih čestica određene vrste na zidovima reaktora [40]. U našoj laboratoriji su ovom metodom već rađena merenja pobuđenih čestica u atmosferskom pražnjenju a u ovoj disertaciji će biti prikazani rezultati merenja u pražnjenju na niskom pritisku.

1.2.2 ELEKTRIČNA KARAKTERIZACIJA RADIO-FREKVENTNIH PRAŽNJENJA – DERIVATIVNE SONDE I MERENJE SNAGE

Intuitivno je jasno da će snaga koja se predaje plazmi direktno uticati na mnoge osobine pražnjenja poput energije svih aktivnih čestica u plazmi ili njihovih flukseva prema elektrodama ili zidovima komore. U najopštijem obliku srednju snagu možemo da predstavimo kao integral proizvoda struje i napona u toku n perioda (T):

$$P = \frac{1}{nT} \int_0^{nT} I(t)V(t)dt. \quad (1.66)$$

Kao merilo uniformnosti različitih GEC komora Hargis je odabrao upravo njihove električne osobine [17]. U praksi je, međutim, pogotovo kod radio frekventnih pražnjenja, stvar nešto komplikovanija. Naime struja koja od napajane elektrode ide ka plazmi, odnosno ka uzemljenoj elektrodi, često „vidi“ više od jednog uzemljenja prema kome može da se usmeri [41]. To je najčešće uzrokovano geometrijom komore, odnosno njenim zidovima koji su praktično uvek uzemljeni. Slična stvar postoji i kod merenja napona jer, zavisno i od pozicije na kojoj se meri, postoji čitav niz parazitnih kapacitivnosti koje mogu uticati na rezultat [41], [42]. Takođe, treba imati u vidu i da svaki konektor u određenoj meri ima neku karakteristiku elementa kola (otpor, kapacitivnost, induktivnost) što se odnosi i na kablove, kod kojih je bitan parametar dužina. To sve predstavlja dodatne elemente koji se unose u električno kolo. Kao ilustraciju ćemo skrenuti pažnju na činjenicu da brzini svetlosti, što je brzina putovanja signala kroz kablove, treba oko 3,34 ns da pređe put od jednog metra. Kako period oscilovanja na frekvenciji od 13,56 MHz iznosi 73,75 ns, to znači da bi ova razlika u dužini između dva kabla u sistem unela grešku od oko 5%.

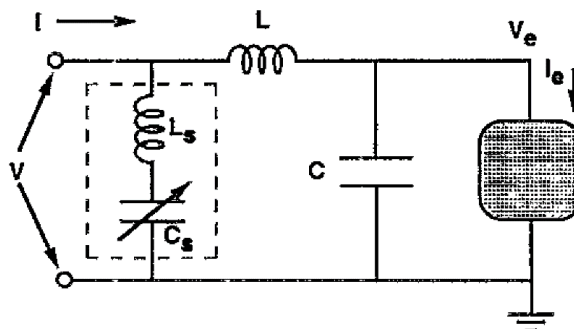

Slika 1.2.8 Pojednostavljena električna šema komore za pražnjenje sa dodatnim šantom. L i C su vrednosti spoljašnjeg kola, isprekidanom linijom je označen šant a plazma crnom kutijom [17].

Kako bi se ove sistematske greške u merenju svele na minimum predloženo je nekoliko različitih rešenja. Jedna ideja je da se u kolo postavi dodatni element, odnosno šant (*eng shunt*) [17]. Konstruiše se tako da mu je induktivnost L_s fiksna a da je moguće menjati njegovu kapacitivnost C_s . Da bi se podesila odgovarajuća vrednost, kroz potpuno evakuisanu komoru se pušta signal male amplitude i C_s se menja sve dok merena struja ne padne na nulu. U tom trenutku će se ukupna reaktansa sistema i reaktansa šanta potirati:

$$j\omega L_s + 1/j\omega C_s = -(j\omega L + 1/j\omega C), \quad (1.67)$$

odnosno na ovaj način su efekti spoljašnjeg električnog kola na proces merenja eliminisani. U poslednjoj formuli su sa L i C obeležena induktivnost i kapacitivnost spoljašnjeg kola. Kad su ovi uslovi ispunjeni snaga može da se računa po formuli:

$$P = \frac{1}{2} \sum_n V_n I_n \cos \varphi_n. \quad (1.68)$$

Ovde je sa indeksom n obeležen n -ti harmonik napona ili struje a φ predstavlja faznu razliku između njih. Pojednostavljena električna šema plazme gde je dodat ovaj element je prikazana na slici 1.2.8. Nesavršenost ove metode se ogleda u činjenici da je pretpostavljeno da se i šant i spoljašnje kolo mogu opisati samo svojim reaktansama, iako u realnosti oni imaju i rezistivnu komponentu.

Još jedan metod eliminisanja efekata spoljašnjeg kola predložio je Miler [43]. Naime, on je primetio da će osobine plazme, poput snage ili vršnih vrednosti napona, biti drugačije čak i kada se napajanje vrši nominalno identičnim izvorima. Zaključio je da plazma na neki način spregnuta sa spoljašnjim kolom koje svojom nelinearnom prirodom utiče na merenje. Ovaj problem je u značajnoj meri rešio konstruisanjem filtera koji je propuštao samo osnovni harmonik frekvencije kojom se sistem napaja a sve više harmonike je reflektovao. Na ovaj način se ne utiče na inherentno nelinearne osobine same plazme ali je ona praktično odvojena od nelinearnih osobina spoljašnjeg kola. U svojim eksperimentima Miler je filtere postavljao što je bliže mogao komori za pražnjenje a oni su danas često sastavni deo kola za prilagođenje.

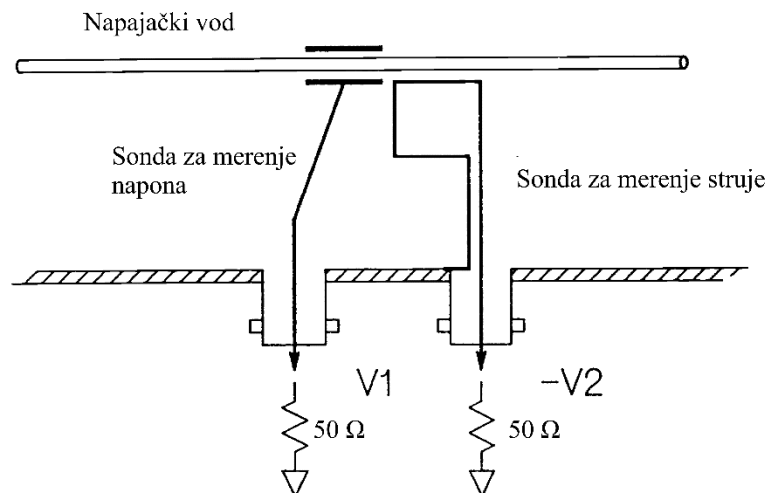

Slika 1.2.9 Primer konstrukcije derivativnih sondi [44].

Za merenje visokofrekventnih signala struje i napona konstruisane su takozvane derivativne sonde. Iako su razvijene još sredinom 60-ih godina prošlog veka, aktivniju upotrebu su doživele krajem njegove poslednje decenije [17], [44]. Sonda koja služi za merenje napona je napravljena tako da sa vodom za napajanje ima kapacitivnu spregu a u početku su pravljene kao prsten oko napajanog voda. Za merenja struje se koristi sonda koja će imati induktivnu spregu a pravi se kao mali kalem pobuđen promenljivim poljem kabla kojim se snaga predaje plazmi. Primer konstrukcije je dat na slici 1.2.10. Ime su dobile po tome što se vrednosti merenih veličina dobijaju preko promene napona na sondama, odnosno zavise od njegovog izvoda (*eng derivative*). Pogodnosti upotrebe derivativnih sonde leže u njihovoj maloj ceni, dobroj linearnosti i širokom opsegu frekvencija u okviru kog mogu da se koriste. Mana im je potreba za faznom i amplitudnom kalibracijom i nemogućnost merenja jednosmernih signala. Tokom samog procesa merenja poželjno je da aparatura ne bude u direktnom kontaktu sa kolom za napajanje ali i da bude što je bliže moguće samoj napajanoj elektrodi, odnosno plazmi [42].

Napajački sistem koji je korišćen tokom izrade ove disertacije ima automatsko kolo za prilagođenje a električne osobine su ispitivane derivativnim sondama razvijenim u našoj laboratoriji [45], [46].

1.2.3 OPTIČKA EMISIONA SPEKTROSKOPIJA I OPTIČKA AKTINOMETRIJA

Optička emisiona spektroskopija, OES, je jedna od najčešće korišćenih dijagnostičkih metoda za neinvazivno ispitivanje plazme. Bazira se na činjenici da će pobuđeni atomi tokom deekscitacije emitovati zračenje na određenim talasnim dužinama. Kada imamo zračenje ovakvog tipa onda govorimo o emisionim linijama. Kod molekula se pored linija pojavljuju i takozvane emisione trake, odnosno zračenje u određenom opsegu talasnih dužina koje pored spektara emisije usled prelaza sa različitih elektronskih nivoa sadrži i emisiju sa različitih vibracionih i rotacionih nivoa. Primer optičkih spektara sa naznačenim molekulskim trakama i atomskim linijama dat je na slici 1.2.10. Analiza zračenja iz plazme, koje se najčešće predstavlja kao intenzitet u zavisnosti od talasne dužine, predstavlja osnovu OES metode. Njenom primenom se pre svega može izvršiti identifikacija pobuđenih vrsta koje učestvuju u pražnjenju [47] ili, ako u njemu učestvuje samo jedna vrsta, odnos različitih izotopa [48]. Danas se takođe koristi za dobijanje odgovora na široku paletu pitanja važnih za osobine plazme kako u nauci tako i u industriji. Primenjuje se u kontroli procesa pri proizvodnji tankih dijamantskih [49] ili SiO₂ [50] filmova, proizvodnji nano cevčica [51] pa čak i za praćenje procesa sterilizacije medicinske opreme [52]. Tokom nagrivanja ili depozicije se može koristiti za merenje brzine procesa [53] ili identifikaciju pobuđenih vrsta [54]. U prethodnim poglavljima je već istaknut značaj elektrona za procese u neravnotežnim pražnjenjima, pa je korisno pomenuti da se OES metoda može koristiti za određivanje njihove temperature, odnosno energije [55], u induktivno [56] i u kapacitivno spregnutim pražnjenjima [57] kao i dobijanje funkcije raspodele elektrona po energijama [58].

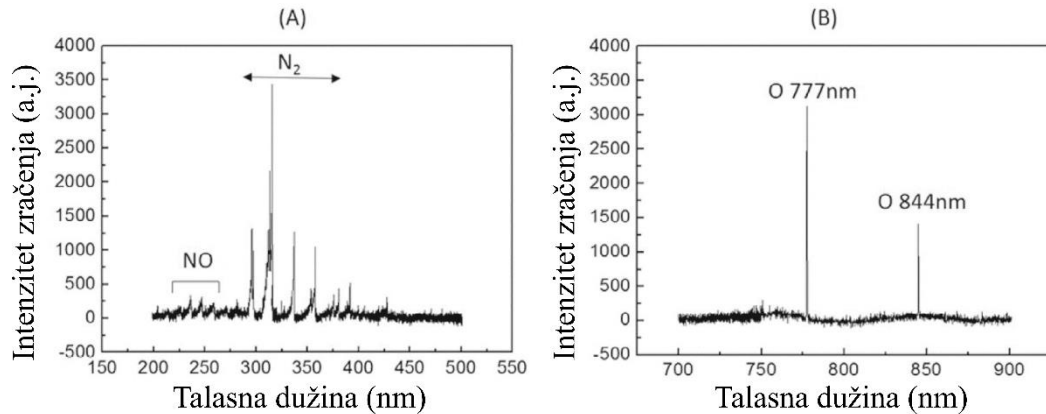

Slika 1.2.10 Primer optičkih spektara sa A) naznačenim molekulskim trakama (druga pozitivna traka N₂) i B) atomskim linijama (O linije).

Jedna od tehnika baziranih na OES metodi od posebnog interesa za nas je aktinometrija – optička metoda koju su razvili Koburn i Čen (Coburn, Chen) a kojom je moguće odrediti apsolutne koncentracije određenih vrsta poređenjem intenziteta linija dva različita gasa [59]. Obično se kao gas čija je koncentracija u pražnjenju poznata koristi argon i taj gas se zove aktinometar [60]. Gas kome se određuje koncentracija atoma, merni gas, može da bude vodonik [60], [61], kiseonik [62], [63], azot [64] ali tehnika je primenjivana i za druge gasove. Pored apsolutnih koncentracija atomskih vrsta u osnovnom stanju može da se dobije i stepen disocijacije molekula mernog gasa [63], [64], zatim koncentracija čestica u konkretnom pobuđenom stanju [65] pa čak i koncentracija pojedinih jona [66].

U našim merenjima OES metoda je primenjena kako bi se otkrile linije koje se javljaju u spektru pražnjenja, a koristili smo aktinometriju za određivanje apsolutnih koncentracija atomskog kiseonika i stepena disocijacije molekulskog kiseonika.

1.2.4 SNIMANJE SLIKA iCCD KAMEROM (IMAGING)

U različitim tipovima optičkih merenja u kojima se dobijaju prostorno-vremenski profili emisije iz plazme kao detektor, odnosno senzor, se danas najčešće koristi digitalna kamera. Jedan od tipova ovakve kamere, koja je korišćena i u našem eksperimentu, nosi oznaku ICCD (*eng* Intensified Charge-Coupled Device). Ova kamera je opremljena pojačavačem signala. Ovaj uređaj ima tri glavna dela: fotokatodu, ploču sa mikrokanalima (*eng* microchannel plate) i fosforni ekran. Svetlost koja prođe kroz objektiv kamere prolazi kroz evakuisanu ulaznu cev i dolazi na fotokatodu. Zavisno od kvantne efikasnosti fotokatodnog sloja, nakon što ga udari foton određene energija (talasne dužine), dolazi do emisije elektrona. Električnim poljem se elektron prevodi preko malog međuprostora, dužine oko 0,2 mm, do mikrokanalne ploče. Ona je napravljena od stakla, debljine je oko 1 mm i ima veliki broj kanala koji se jedan uz drugi nalaze u formi pčelinjeg saća (slika 1.2.11 a)). Svaki kanal je presvučen provodnim slojem sa ukupnom razlikom napona od 500 do 1000 V između krajeva. Kaskadnim sudarima sa zidom, kao u klasičnom fotomultiplikatoru, stvara se lavina elektrona tako da finalno pojačanje na izlazu iz mikrokanalne ploče može biti i do 10⁴ (slika 1.2.11 b)). Zatim se elektroni visokim naponom ubrzavaju kroz još jedan međuprostor ka fosfornom ekranu. Nakon sudara sa ekranom elektroni oslobađaju fotone koji, sada pojačan signal, šalju do CCD senzora na kome se vrši digitalizacija.

Na ovaj način upadni signal fotona se višestruko povećava a pojačanje sistema (*eng gain*) se reguliše podešavanjem napona na mikrokanalnoj ploči. Pored toga, regulacijom napona na mikrokanalnoj ploči može se u potpunosti zaustaviti fluks elektrona kroz mikrokanalnu ploču. Pošto se promene naponskog signala mogu vršiti u izuzetno kratkim vremenskim periodima (reda veličine 1 ns) mikrokanalna ploča se može koristiti kao 'brza blenda' omogućavajući izuzetno precizna i kratka vremena ekspozicije koja su nedostižna za mehaničke uređaje.

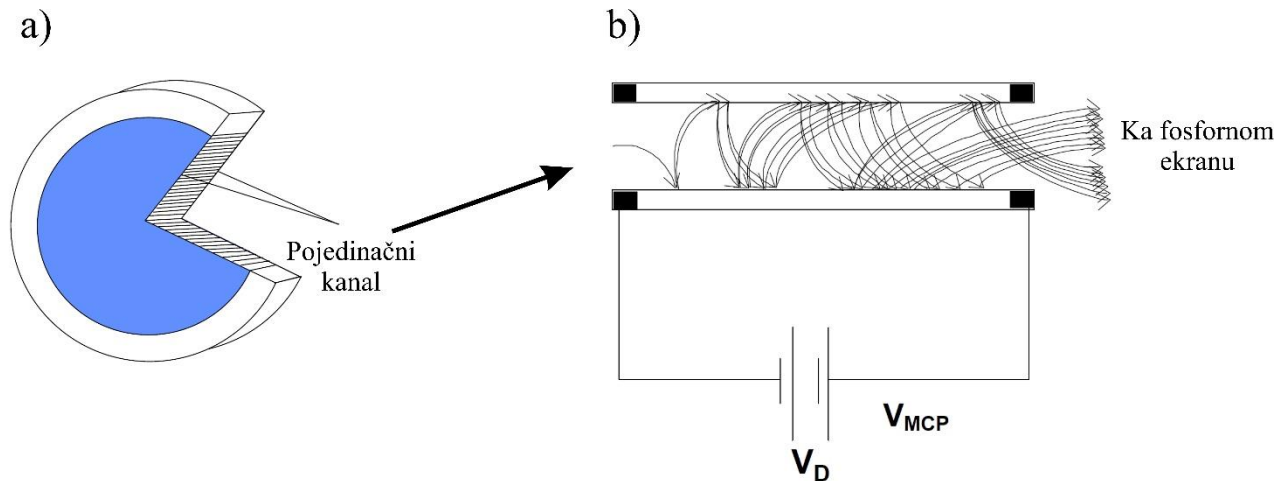

Slika 1.2.11 Najvažniji deo pojačavača je mikrokanalna ploča a). Sačinjena je od velikog broja fotomultiplikatora b), koji su u njenoj unutrašnjosti raspoređeni u formi pčelinjeg saća.

Zbog mogućnosti velikog pojačanja signala, izuzetno je bitno da se minimizuje šum u detektoru. Kako bi se smanjio šum zbog termalnih efekata na CCD čipu, kamere su obično opremljene Peltijeovim hladnjakom koji temperaturu čipa može da spusti i do $-30\text{ }^{\circ}\text{C}$.

1.2.5 LANGMIROVA SONDA

Tokom merenja plazma parametara, često je potrebno dobiti i njihove prostorne raspodele. To podrazumeva da merenja moraju da budu lokalna što se najlakše postiže upotrebom sonde. U svrhu merenja koncentracija naelektrisanih čestica u plazmi početkom 1920.-ih godina Irvin Langmir je razvio posebnu tehniku koja danas nosi ime po svom pronalazaču. U osnovi tehnike nalazi se Langmirova sonda koja predstavlja komad žice koji se uranja plazmu. Sonda se napaja promenljivim naponom i meri se struja kroz nju. Tokom vremena razvijeno je mnogo načina na koji se sonda može konstruisati a tri najosnovnija, cilindrični, sferni i planarni, predstavljena su na slici 1.2.12.

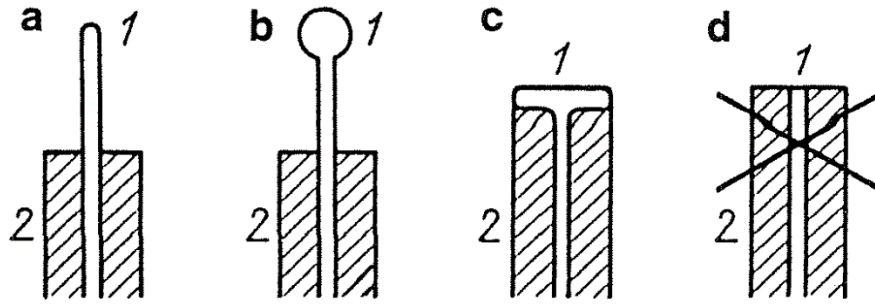

Slika 1.2.12 Tri osnovna tipa konstrukcije Langmirove sonde a) cilindrični, b) sferni, c) planarni i d) primer loše konstruisane sonde [9].

S obzirom da će se vrh sonde nalaziti u pražnjenju gde će biti izložen visokim temperaturama i česticama velike energije, potrebno je da bude napravljen od materijala koji ovakve uslove može da izdrži. U tu svrhu se najčešće koristi volfram ali su u upotrebi i materijali poput molibdena i tantala. Ukoliko se očekuje da će tokom rada vrh sonde biti izložen izrazito velikom fluksu jona koji mogu da oštete ili istope njegovu površinu, poželjno je da se onda koristi grafit. Dužina cilindričnog vrha je obično između 2 i 10 mm dok mu je prečnik između 0,05 i 1 mm [4], [9]. Karakteristične dimenzije kod sfernih i planarnih vrhova su reda veličine 1 mm. Materijal nosača sonde bi trebalo da bude od neke vrste izolatora i u tu svrhu se najčešće koriste keramike poput Al_2O_3 . Da bi se perturbacija plazme svela na minimum poželjno je da nosač bude što tanji ali i da ne dodiruje vrh same sonde, kako bi se smanjila šansa da on dođe u kontakt sa provodnim materijalom koji se može deponovati na površini izolatora.

Kako bi merenja ovom metodom bila validna mora se voditi računa o tome da perturbacija koja će se uneti u plazmu ne bude prevelika. Zbog toga je poželjno da karakteristične dimenzije sonde, odnosno njenog vrha, budu manje od dužine srednjeg slobodnog puta čestica u pražnjenju. Takođe, ukoliko su uslovi veoma agresivni tada neće biti moguće da se merenje obavi tokom jedne kontinualne promene napona. Rešenje je da se sonda u kratkim vremenskim intervalima uvlači i izvlači iz plazme ili da se merenje obavlja impulsnom primenom napona. Imajući ovo u vidu, jasno je da postoje određena ograničenja primenljivosti ove metode, koja se u glavnom odnose na visoke temperature ili koncentracije naelektrisanih čestica. Ipak, uz odgovarajuću konstrukciju i pažljivo tumačenje rezultata, Langmirove sonde mogu da daju pouzdane rezultate u širokom opsegu parametara koji podrazumevaju pritiske od nekoliko mTorr do nekoliko Torr-a (okvirno 1-1000 Pa) i koncentracije elektrona do 10^{14}m^{-3} . Problemi u merenju mogu nastati kada je koncentracija negativnih jona značajna ili ako u prostoru pražnjenja postoji magnetno polje. Tada se primenjuju dvostruke sonde.

Postoje dva osnovna načina za primenu napona i merenje struje koji su šematski su prikazani na slici 1.2.13. Prvi način, prikazan na levoj strani slike, podrazumeva da se sonda poveže sa promenljivim izvorom napona a da se struja meri kao pad napona na uzemljenom otporniku. Na ovaj način će uzemljenje značajno smanjiti postojanje lažnih signala. Problem kod ovakvog povezivanja je što će sam izvor napona „plivati“ jer on neće biti povezan na uzemljenje. Takođe, velika kapacitivnost izvora može za naizmjenične signale da predstavlja kratki spoj, čime će oni praktično zaobići otpornik na kome se meri struja. U tom slučaju će frekventni odziv sonde biti loš. Da bi se to izbeglo, povezivanje može da se uradi i na drugi način, predstavljen na desnoj strani slike, kada će jedna strana otpornika biti povezana na uzemljeni izvor napajanja a druga strana na sondu. U toj situaciji se merenje nad otpornikom obavlja nekim uređajem koji može da meri plivajući napon, poput diferencijalnog pojačavača.

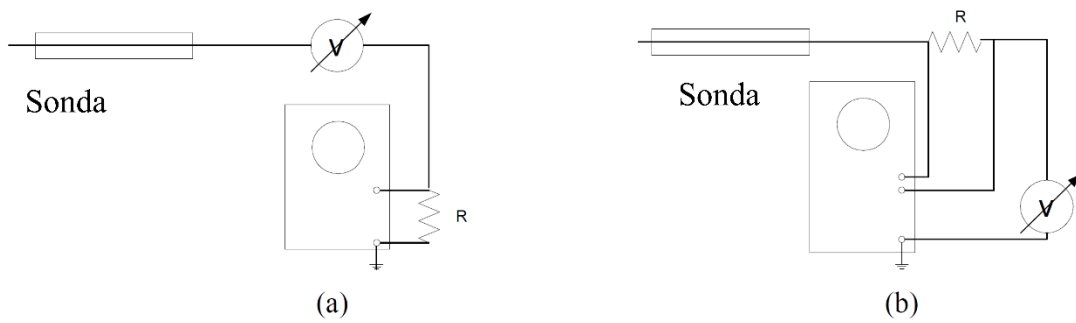

Slika 1.2.13 Struja na Langmirovoj sondi može da se meri preko a) uzemljenog ili b) neuzemljenog otpornika [4].

Strujno-naponska kriva Langmirove sonde se obično crta tako da joj se elektronski deo nalazi na pozitivnom delu y-ose kao što je predstavljeno na slici 1.2.14 a sačinjena je od 5 karakterističnih delova. Plivajući potencijal, V_f (*eng floating potential*), je mesto gde ona preseca x-osu. Sa njegove leve strane je napon negativan, odnosno sonda privlači pozitivne jone. Oblast jonskog dela krive na kome se struja slabo menja se naziva jonska struja saturacije i obeležava se sa I_{sat} . Sa desne strane plivajućeg potencijala se nalazi eksponencijalni ili tranzicioni deo krive. U njemu sonda, povećavanjem napona, privlači sve veći broj elektrona. Na mestu plazmenog potencijala, V_s (*eng space potential*), nalazi se takozvano koleno posle koga elektronska struja ulazi u saturaciju - I_{es} . U idealnom slučaju će i jonska i elektronska struja saturacije biti paralelna sa x-osom. Oblik I-V karakteristike koji je najpribližniji idealnom imaju planarne sonde.

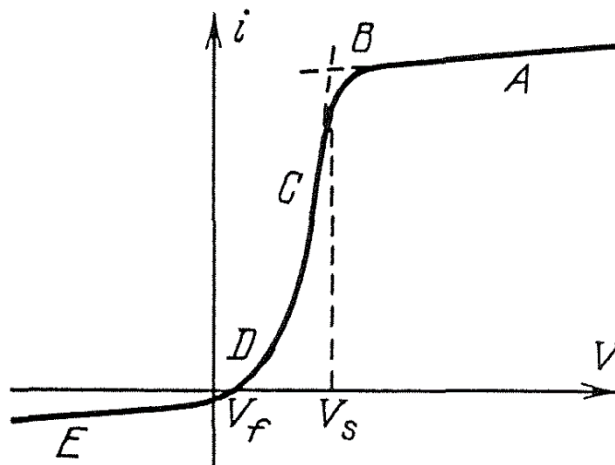

Slika 1.2.14 Karakteristični delovi I-V krive Langmirove sonde: A – elektronska struja saturacije I_{es} , B – V_s ili koleno, C – tranzicioni deo I_e , D – plivajući potencijal V_f , E – jonska struja saturacije [9].

U prelaznom delu će struja elektrona biti:

$$I_e = I_{es} \exp\left(\frac{e(V_p - V_s)}{kT_e}\right) \quad (1.69)$$

gde je:

$$I_{es} = \frac{eAn_e\bar{v}}{4} = eAn_e \left(\frac{kT_e}{2\pi m} \right)^{1/2} \quad (1.70)$$

Ovde je sa A obeležena površina vrha sonde a sa V_p napon na njemu. U slučaju Maksvelove raspodele elektrona po energijama, na polulogaritamskom grafiku će $I_e(V_p)$ biti prava linija. Iz navedenog je jasno da će u tom slučaju nagib krive u njenom prelaznom delu biti proporcionalan sa $1/T_e$, što se koristi prilikom procene temperature elektrona i neće zavisiti od površine sonde. Takođe, nagib neće zavisiti ni od broja elektronskih sudara u blizini sonde jer se u sudarima oblik distribucije ne menja. U oblasti u kojoj sonda odbija elektrone, odnosno tamo gde je $V_p < 0$, će za Maksvelove elektrone da važi proporcionalnost:

$$f(v) \propto e^{-\frac{\left(\frac{mv^2}{2} + eV\right)}{kT_e}} = e^{-\frac{-e|V|}{kT_e}} e^{-\frac{mv^2}{2kT_e}}. \quad (1.71)$$

Uzimajući ovo u obzir, možemo da procenimo da će elektronska struja saturacije biti veća od jonske oko $(M/m)^{1/2}$ puta. Međutim, ovo neće da važi ukoliko je pritisak veliki, jer će povećanje napona na sondi da dovede do povećanja zapremine oblasti u kojoj će elektroni osećati ovu promenu. Odnosno, efektivna površina sonde će se praktično povećavati i to će uticati i na oblik I-V krive. Zbog toga procenu koncentracije elektrona na osnovu I_{es} treba raditi samo u slučaju malih pritisaka, tj. velikih srednjih slobodnih puteva. U svim ostalim slučajevima, bolje je računati koncentraciju jona pa iz pretpostavke kvazineutralnosti dobiti n_e .

Ukoliko je I_{es} ima relativno jasan plato, plazmeni potencijal može da se dobije u preseku produženih linija u kojima su I_e i I_{es} najbolje definisane, kao tačka B na slici 1.2.14. Drugi način određivanja V_p je da se nađe tačka u kojoj I_e počinje da odstupa od eksponencijalne funkcije, odnosno da se nađe maksimum njenog prvog izvoda ili nula drugog izvoda. Mana prvog metoda je njegova neprimenljivost u slučaju da I_{es} ima nepravilan oblik. Kod drugog metoda je problem što struja u toj oblasti eksponencijalno zavisi od napona pa male greške u proceni V_s dovode do velike greške u I_{es} .

Dobijanje koncentracije naelektrisanih čestica je najjednostavnije preko saturacione struje jona u slučaju planarnih sondi. Prielektrodna oblast oko negativno naelektrisane sonde će biti tanka pa će njena površina biti jednaka površini sonde. U tom slučaju se I_{sat} dobija iz Bomovog kriterijuma:

$$I_{sat} = 0,5eAn \left(\frac{kT_e}{M} \right)^{1/2}, \quad (1.72)$$

faktor 0,5 je uzet iz uslova da je $n_e/n = 0,5$. U praksi je vrednost ovog faktora nešto veća.

U slučaju cilindričnih i sfernih sondi situacija je značajno komplikovanija jer će povećanje napona u svakom slučaju dovesti do povećanja prielektrodne oblasti koja okružuje sondu a saturaciona struja će imati određen nagib. Međutim, postoji nekoliko teorija koje se bave ovim problemom. Najjednostavnija, i za nas najznačajnija, je takozvana OML (*eng* Orbital Motion Limited) teorija, koju je predložio sam Langmir. Bez ulaženja u detaljne jednačine, ona se zasniva na ideji da joni ka sondi dolaze iz beskonačnosti gde je napon nula i polako se menja sve do sonde gde iznosi $-V_p$. Uz poštovanje zakona održanja energije i momenta impulsa, dobija se jednačina koja povezuje jonsku struju I , masu jona M , njihovu koncentraciju n i napon na sondi V_p :

$$I = A_p n e \frac{\sqrt{2}}{\pi} \left(\frac{|eV_p|}{M} \right)^{1/2}. \quad (1.73)$$

Oblik zavisnosti struje od napona će imati oblik parabole dok će $I^2(V_p)$ biti prava linija. Da bi ova teorija mogla da se primeni dimenzije sonde moraju da budu znatno manje od veličine prielektrodne oblasti a promene napona ne smeju da budu previše brze.

ABR teorija, koja nosi ime po inicijalima svojih pronalazača Allen, Boyd, Reynolds, u razmatranju problema jonske struje uzima u obzir postojanje prielektrodne oblasti, ne zahteva da

promene napona budu spore ili male ali ne uzima u obzir orbitalno kretanje jona već se pretpostavlja da se iz beskonačnosti joni kreću direktno ka sondi.

Postoji i treća teorija, BRL (Bernstein, Rabinowitz, Laframboise). Njom je obuhvaćeno i orbitalno kretanje jona i postojanje prielektrodne oblasti a ulogu u računu igra i dimenzija sonde. Međutim, zbog komplikovanosti računa ona je nešto manje u upotrebi.

Iako su konstrukcija i proces merenja Lagnmuirovom sondom relativno jednostavni, tumačenje rezultata i teorije kojima se ona opisuje su kompleksni i mogu da utiču na određivanje parametara plazme. Na ovom polju istraživanja i dalje traju [67] a ova vrsta sonde se aktivno koristi za ispitivanje neravnotežnih plazmi na niskom pritisku, kako induktivno [68] tako i kapacitivno [69], [70] spregnutih ali i prašnjavih plazmi (*eng* dusty plasmas) [71].

1.3 PRIMENE RADIO-FREKVENTNIH PRAŽNENJA NA NISKIM PRITISCIMA

Neravnotežne plazme se danas primenjuju u velikom broju različitih industrija ali najvažniji doprinos su dale od 70-tih godina 20. veka kada su počele da se koriste u procesima vezanim proizvodnju mikro čipova [3], [4], [6]. Procesi plazma nagrivanja i depozicije tokom proizvodnje minijaturnih električnih kola su zamenili takozvane vlažne procese, odnosno hemijske metode koje su se u početku koristile. Njihovom upotrebom, zbog izotropne prirode hemijskog nagrivanja, nastaju kanali kojima je dubina istih ili veoma sličnih dimenzija kao i širina. Rezultat takvog procesa je prikazan na slici 1.3.1 a). Zbog toga dodatna minijaturizacija poluprovodničkih elemenata u mikroelektronici takvim metodama nije bila moguća sve dok u proizvodnji nisu počele da se koriste neravnotežne plazme na niskom pritisku. Njima se može postići izrazito anizotropno nagrivanje, odnosno mogu se napraviti kanali čija je dubina znatno veća od širine, kao što je prikazano na slici 1.3.1 b), čime su otvorena vrata za proizvodnju modernih integrisanih kola. Zanimljivo je napomenuti da se plazma koristi okvirno gledano u jednoj trećini procesa koji su potrebni da se napravi mikro čip. U poslednjih desetak godina se uveliko rade istraživanja vezana nagrivanje kojima je moguće ukloniti slojeve debljine jednog atoma [72], [73].

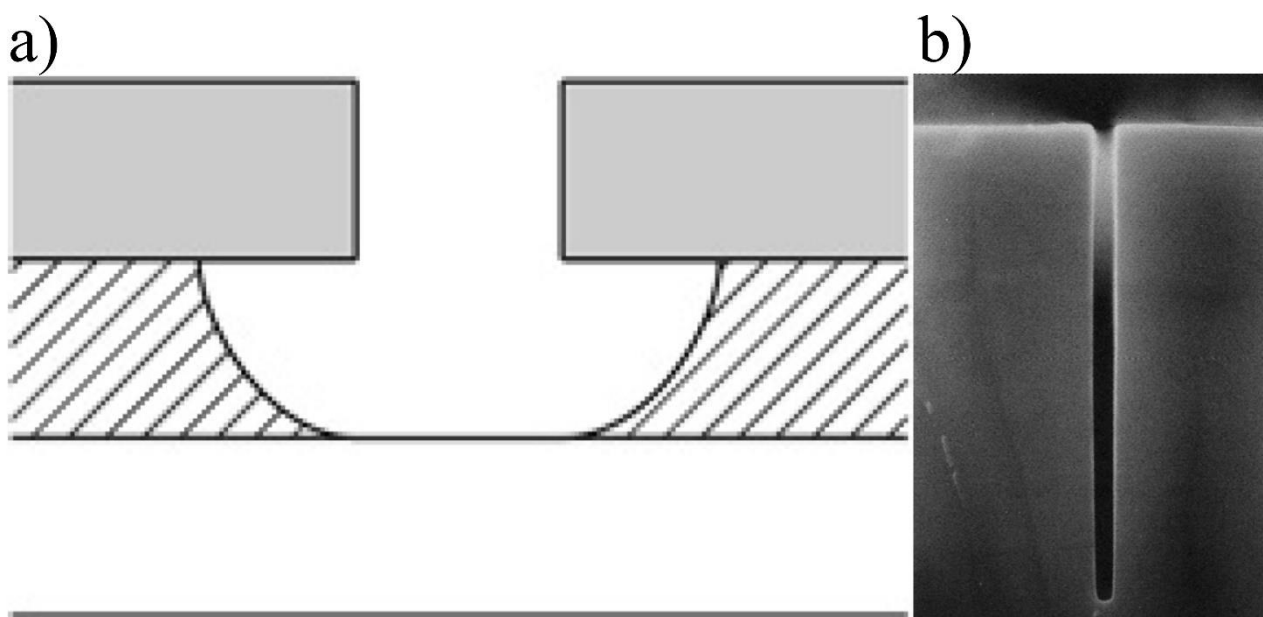

Slika 1.3.1 Rezultat nagrivanja a) izotropnim hemijskim procesima i b) anizotropnim procesima upotrebom neravnotežne plazme [6].

Pored proizvodnje elektronskih uređaja, neravnotežne plazme mogu da se koriste i za pripremu odnosno aktiviranje različitih vrsta površina pre farbanja ili pre nanošenja određenog materijala. Ničke (Nitschke) je pokazao da se nakon izlaganja plazmi na fluoro-karbonski polimerni lanac mogu hemijskim reakcijama spojiti monomeri ili polimeri ali i da se polimer može pričvrstiti tako što se nakon nanošenja na fluoro-karbonsku površinu izloži plazmi [74]. Pokazano je i da se na sličan način može poboljšati adhezija PPS (Polyphenylene sulfide) plastike na aluminijum. Ukoliko se pre nanošenja adheziva, izvrši tretiranje plastične površine poboljšanje iznosi između 79% ako je tretman obavljan u argonskoj do čak 134% ako je tretman urađen u kiseoničnoj plazmi [75]. Primena suvih metoda tokom nanošenja polimernih materijala umesto hemijskih ima i velike ekološke benefite a pored relativno velikih početnih ulaganja može da bude i finansijski isplativa [76]. Ilustrativan je primer fabrike u Švajcarskoj u kojoj je niskotemperaturna plazma korišćena za čišćenje metalnih i elektronskih komponenti. Pored toga što je oštećenje površina bilo znatno manje, nakon prelaska na suve metode čišćenja u pogonu je umesto 6000 kilograma metilhloroforma (1,1,1-trichloroethane) godišnje potrošnja spala na svega 60 kg CF₄ [77]. Osim čišćenja, plazma može da se koristi i u procesu nitriranja metala, pogotovo kod mehaničkih delova koji trpe veliko opterećenje [78].

Posebno zanimljiva je primena ovakvih vrsta pražnjenja u cilju očuvanja arheoloških artefakata. Naime, proces korozije počinje onog trenutka kada predmet upadne u zemlju ali je zbog manjka kiseonika u njoj on vrlo često spor i takvoj sredini može da opstane i nekoliko hiljada godina [79]. Međutim nakon što se artefakt iskopa i izloži vazduhu, proces se nastavlja i može da dovede do kompletne dezintegracije u svega nekoliko decenija. Dodatni problem je što sloj Fe₂O₃ i blata koji se nalazi na površini predmeta može da bude toliko debeo da njegov originalni oblik ne može da se prepozna pa uspešnost restauracije često zavisi jedino od iskustva restauratora. Međutim, primenom vodonične plazme je moguće ukloniti slojeve korozije i prljavštine sa površine tako da se oni hemijskim putem prevedu u isparljive supstance i na takav način da originalni oblik bude lako uočljiv. Na slici 1.3.2 je pokazna uspešnost ove metode na primeru restauracije rimskog ključa. Ovaj metod je pored gvožđa upotrebljen i na uzorcima od srebra i bronzе i uspešno testiran na 14000 različitih primeraka [80]. Kasnije je ustanovljeno da je pored početnog tretmana plazmom potrebno primeniti još nekoliko koraka kako bi se očuvala dugoročna stabilnost od korozije [81].

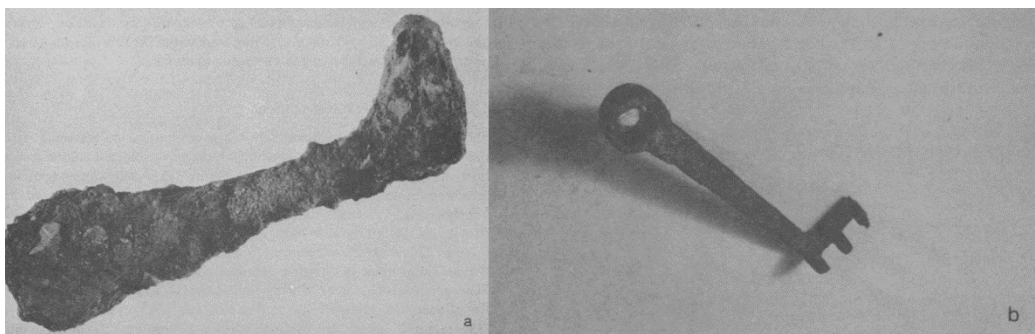

Slika 1.3.2 Rimski ključ pre (a) i posle restauracije tretmanom vodoničnom plazmom na niskom pritisku (b) [79].

Postoji velika oblast primene neravnotežnih plazmi u medicini i biologiji ali se tu u najvećoj meri koriste plazme na atmosferskom pritisku zbog same prirode tretiranih uzoraka. Pražnjenja na niskom pritisku, sa druge strane mogu da imaju veoma važnu ulogu u sterilizaciji medicinske opreme i implanata. Za uništavanje bakterijskih spora tokom tretmana su u najvećoj meri odgovorna dva procesa [82]. Prvi je izlaganje ćelijskog DNK ultraljubičastom zračenju iz plazme. Treba obratiti pažnju da postoji određena minimalna doza zračenja koja će izazvati takvo oštećenje da bakterije

neće biti u stanju da poprave DNK lanac. Drugi proces je fizičko i hemijsko nagrivanje površine koje će dovesti do njenog potpunog uništenja i ubijanja spore. Kako bi i jedan i drugi proces bili uspješni, najbolje je koristiti smešu u kojoj se nalaze Ar, O₂ i N₂ [83]. Na taj način se koristi mogućnost smeše kiseonika i azota da emituje intenzivno UV zračenje ali i potencijal Ar/O₂ smeše koja omogućava uspješno fizičko i hemijsko nagrivanje i uklanjanje materijala. Još jedna važna primena ovakvih pražnjenja je u pripremi površine potke (*eng scaffold*) za izgradnju kostiju. Ovakve skele se često prave kao 3D supstrat preko koga će da naraste željeno tkivo a materijal od koga se prave treba da bude biokompatibilan, biorazgradiv, da promovise nastajanje veza između ćelija i da ima odgovarajuća mehanička svojstva [84]. Za pripremu površine ovakvih uzoraka se često koriste plazme u kojima se nalazi radni gas koji sadrži azot, poput amonijaka [85].

1.3.1 PRIMENE U TRETMANU TEKSTILA

Za nas su od posebnog interesa primene niskotemperaturnih plazmi na niskom pritisku u tretmanima tekstila. Za početak, važno je ustanoviti kakvu vrstu promene plazma uopšte može da napravi na tekstilu, odnosno da li su njeni efekti ograničeni na samu površinu ili utiču i na unutrašnjost uzorka. Ovim pitanjem su se još krajem 70-tih godina prošlog veka bavili Bat i Nadiger (Bhat, Nadiger). U svojim istraživanjima su koristili induktivno spregnuto pražnjenje u azotu u tretmanu tasar svile [86]. Upotrebom elektronskog mikroskopa su ustanovili da na površini tretiranog uzorka dolazi do uklanjanja zrnastog materijala koji je, pre tretmana, u velikoj meri prekrivao vlaknastu strukturu svile. Drugim dijagnostičkim metodama ustanovili su da unutrašnjost uzorka ostaje praktično nepromenjena. Time je ustanovljeno da su u ovim tretmanima efekti plazme na tekstilne uzorke površinske prirode. U istom periodu se sličnim istraživanjima na PET tkanini bavila Aleksandra Vrobel (Wróbel) ali u kapacitivno spregnutim plazmama. Kao radne gasove je koristila kiseonik, azot, ugljendioksid i amonijak i zaključila da su efekti tretmana uočljivi do dubine od 50 do 500 Å [87], što okvirno gledano predstavlja debljinu sloja od nekoliko desetina atoma.

U istraživanjima je takođe primećeno da se izlaganjem tkanina plazmi može uticati na sposobnost materijala da apsorbuje vodu ali i da se te promene vremenom, ili nakon određenog broja pranja, polako gube. Takođe ukoliko je tkanje materijala manje gusto a pritisak u komori dovoljno mali da se aktivne čestice ne gube u sudarima u samom gasu, efekti tretmana mogu da prodru i nešto dublje u unutrašnjost materijala [88]. Pored eksperimentisanja sa različitim vrstama gasova, neki istraživači su pokazali i efikasnost u upotrebi plazma tretmana realizovanog u smeši gasova radi povećanja hidrofobnosti tkanine. Posebno se uspješno pokazala smeša azota, kiseonika i vodonika [89]. Tkanine kojima se na ovaj način obavi suva priprema za nanošenje boje, tj. plazma tretmanom utiče na hidrofobnost površine, znatno će sporije da blede, pri čemu je sam postupak tretmana sa daleko manjim ekološkim posledicama u poređenju sa konvencionalnim metodama [90].

Zanimljivo je da izlaganje pamučne, svilene i PET tkanine SF₆ plazmi, za razliku od većine drugih gasova, zapravo dovodi do povećanja hidrofobnosti tretirane površine [91], [92]. Ova promena se vidi i kroz značajno povećanje kontaktnog ugla ali i u testovima gde se meri vreme koje je potrebno da se apsorbuje ista količina tečnosti. Hidrofobnost materijala se, ipak, najčešće postiže tako što se plazmom aktivira površina na koju se zatim nanese neki drugi materijal koji je hidrofoban. Interesantna je mogućnost da se na poliestersku tkaninu, u kombinaciji sa tretmanom u kiseoničnoj plazmi nanese HMDS (Hexamethyldisiloxane). Pored povećane hidrofobnosti, na ovaj način je i znatno smanjena šansa da će se materijal zapaliti, čak i kad se direktno izloži plamenu [93], pa se tekstilni materijali koji su ovako tretirani mogu koristiti u izradi zaštitne opreme.

Pored nanošenja organskih molekula na površinu tkanine ponekad postoji potreba da se nanese čestice ili sloj nekog metala. Na primer, jedan od načina za nanošenje bakra podrazumeva korišćenje kiseonične ili azotne plazme kako bi se površina uzorka aktivirala. Uzorak sa aktiviranim

površinom se zatim unosi u magnetron sa jednosmernom strujom u kojem se vrši deponovanje bakra [94]. U konkretnom primeru su dugoročniji efekti i ravnomernije nanošenje postignuti upotrebom N_2 kao radnog gasa u tretmanu tekstila. Baktericidno delovanje bakra je bilo primetno i nakon 2000 ciklusa veštačke abrazije tretiranog tekstila. S druge strane, materijal koji se znatno češće koristi kako bi se tkaninama dodala baktericidna svojstva je srebro. Ono se međutim nešto teže vezuje, pa neki autori predlažu njegovu primenu za proizvode za jednokratnom upotrebu [95]. Jedan od načina za dugotrajnije vezivanje je da se neka vrsta veštačke tkanine, poput poliester, izloži plazmi što bi dovelo do toga da se na njenoj površine naprave funkcionalne grupe poput $>C-O$, $>C=O$, $-O-C=O$, $-COH$, $-COOH$. Na ovako pripremljenu površinu se zatim nanosi rastvor $AgNO_3$ i potom neki redukcionni agens [96]. Primećeno je da se povećanjem koncentracije soli u rastvoru dobijaju tkanine sa izraženijim baktericidnim dejstvom. Zavisno od vremena tretmana i pomenute koncentracije moguće je inhibirati i celih 100 % patogena iz vazduha. Nanočestice srebra se mogu naneti i tako što se nakon tretmana plazmom tkanina impregnira koloidnim rastvorom čestica srebra [97]. Dodatno fiksiranje se postiže ponovljenim tretmanima u plazmi, kada do izražaja dolaze i efekti bombardovanja površine jonima srebra, što dovodi do njihove fizičke implantacije. Pored navedenog, baktericidne efekte je moguće postići i nanošenjem čestica TiO_2 [1]. Neki autori su primetili da veličina nanosenih čestica ima uticaj na njihovu postojanost na površini i da se dugotrajniji efekti postižu primenom sitnijih nanočestica. Nakon sličnog procesa nanošenja čestica, primećeno je da „zrna“ veličine 30 nm, posle deset procesa ispiranja, imaju i tri puta veću koncentraciju od onih čiji je prečnik 80 nm [98].

Pored pomenutih osobina tekstila, primenom plazmi je moguće uticati i na tribološka svojstva materijala ali i na osobine poput boje, tvrdoće, otpornosti na savijanje, vazдушnu permeabilnost, skupljanje nakon pranja, termalnih karakteristika i otpornosti na cepanje [99]–[102]. Pобољшanje ovih osobina tekstila posebno je značajno kod specijalnih upotreba tekstila u izradi različite opreme koja se koristi pri ekstremnim uslovima. Posebno su zanimljivi plazma tretmani kojima se tekstilu, poput popularnog denima, postiže iznošeni izgled [103].

1.3.2 PRIMENE U TRETMANU SEMENA

Plazma je u poslednjih par decenija počela da se primenjuje i u oblasti biotehnologije. S obzirom na to da tokom pražnjenja u gasu može da nastane bogat koktel aktivnih čestica i brojne hemijske reakcije, očekivano je da će postojati i značajna mogućnost za efekte na žive organizme. Kako većina biljaka i životinja nije u stanju da izdrži pritiske manje od atmosferskog, neravnotežne plazme na niskom pritisku se u ovom polju primena koriste skoro isključivo za tretman semena. Tretmani plazmom koriste se najčešće kako bi se uticalo na klijavost semena. Jedan od začetnika istraživanja u ovoj oblasti je Džon Volin (John C. Volin) koji je u svom radu iz 2000. godine prikazao efekte pražnjenja u različitim gasovima na različite vrste semena [104]. Za radne gasove je koristio CF_4 , ODFD (octadecafluorodecalin), anilin, hidrazin i cikloheksan i posmatrao je kakvi će efekti biti na klijavost dve vrste graška, rotkvica, soje, kukuruza i pasulja. Iako je efekat plazma tretmana skoro uvek postojao on nije svaki put bio pozitivan, odnosno nije uvek dovođio do povećanja klijavosti i/ili ubrzanja rasta biljaka. Efekat je izrazito zavisio kako od primenjenog gasa tako i od konkretne vrste semena, pa i samih uslova pražnjenja. Na primer, prilikom tretmana cikloheksanom, koji dovodi do stvaranja hidrofobne površine, mogu da se očekuju dva konkurentna procesa. Jedan je da se kroz cepanje velikog molekula uz aktiviranje površine semena ona obloži ovim materijalom što bi neizostavno dovelo ili do smanjenja klijavosti ili do usporavanja rasta. Drugi je da bi aktivne čestice mogle da izvrše nagrizanje površine semena čime bi se kroz tanju ovojnici povećala propusnost za vodu i vazduh, što bi trebalo da dovede do povećanja klijavosti ili bržeg rasta. U ovom gasu su tretirana semena kukuruza i soje i dok kod kukuruza praktično nije bilo nikakve razlike između tretiranog i kontrolnog uzorka kod soje je primećena značajna razlika i u klijavosti i u količini

apsorbovane vode, pogotovo u ranim fazama klijanja. Slične rezultate dobila je i grupa iz Litvanije tokom tretmana dve različite vrste višegodišnjih biljaka u istim uslovima pražnjenja [105]. Kod jedne vrste drveta je plazma delovala u smeru povećanja klijavosti i brzine, dok je kod druge rezultat bio suprotan. Međutim u svim slučajevima tretirano seme je u kasnijim periodima rasta pokazalo bolje parametre, poput broja i površine listova, u odnosu na netretirano [105].

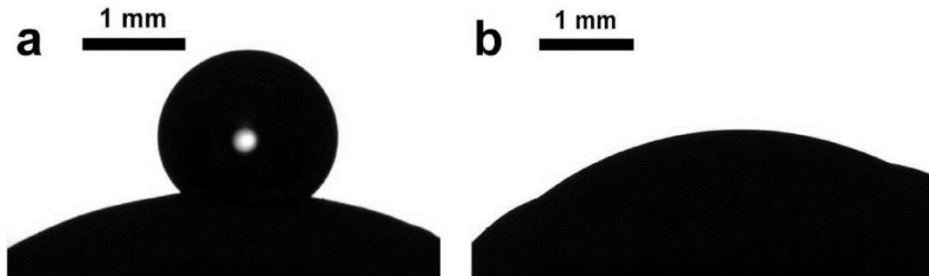

Slika 1.3.3 Kapljica vode na netretiranom (a) i tretiranom (b) semenu sočiva. Rasplinutija kapljica (b) označava bolju hidrofilnost površine semena [106]

Tretmane semena je moguće uspešno obaviti u različitim vrstama plazma reaktora. U tu svrhu se danas koriste radiofrekventna pražnjenja kako induktivne [106], [107] tako i kapacitivne [108], [109] sprege. Međutim, moguće je koristiti i mikrotalasne izvore i to tako što se seme postavi direktno u plazmu [110] ili u oblast koja je malo dalje od aktivne zapremine gde i dalje postoji obilje aktivnih čestica [111], [112]. Uz različit stepen uspešnosti delovanja na klijavost autori su do sada tretirali seme velikog broja biljaka uključujući soju, pšenicu, kukuruz, mak, pasulj, povrće, lešnike, kikiriki, drveće i mnoge druge [2], [104]–[107], [109]–[114]. Kao što su mnogi istraživači uključujući i Volina pretpostavili, razloge za promenu klijavosti kod tretiranog semena treba tražiti upravo u promeni morfologije na površini samog semena. Najlakši način da se ta promena dijagnostikuje je upotrebom elektronskog mikroskopa [104], [106], [114], [115]. Međutim, ukoliko želimo da vidimo kako će površina semena da se ponaša u dodiru sa tečnostima, najefikasniji metod je provera kontaktnog ugla [106], [116]. Manji kontaktni ugao podrazumeva bolju apsorpciju pri čemu je kapljica rasplinutija, kao što je predstavljeno na slici 1.3.3. Pored klijavosti i hidrofilnosti površine semena, pokazano je da se plazma tretmanom može uticati i na brzinu rasta biljke, mogućnost boljeg prihvatanja vode, sadržaja šećera nakon klijanja ali i na aktivnost nekih enzima [105], [109], [110]. Posebno je interesantno što je primećeno da neke vrste biljaka nakon tretmana mogu da razviju otpornost na patogene koja ih prati tokom celog procesa klijanja i rasta čime se direktno utiče i na njihov ukupan prinos [108].

Čuvanje semena se često obavlja u takvim uslovima da je vrlo verovatno da dođe do pojave nekih patogena koji svojim prisustvom mogu da ga učine otrovnim za ljudsku upotrebu ili da onemoguće klijanje. Iako postoje hemijske metode kojima se ovakve situacije mogu suzbiti, one su često takve da prave veliku ekološku ili ekonomsku štetu. Jedno od novih rešenja je primena neravnotežnih plazmi u ovakvim situacijama. Za pionira u ovoj oblasti se smatra Larousi (Laroussi) koji je za svoja istraživanja primenio pražnjenje na atmosferskom pritisku [117]. Poredeći svoje rezultate sa drugim metodama dekontaminacije, koje nisu uvek dobre po prirodno okruženje, poput izlaganja semena toploti, gasovima, UV zračenju ili zračenju fotona dobio je sličnu efikasnost. Poznato je da u plazmi nastaju vrste koje mogu da imaju negativno dejstvo po bakterije, ali visoka efikasnost dekontaminacije plazmom leži u sinergiji prisustva ovih vrsta sa ultra-ljubičastim zračenjem, elektronima, jonima i toplotom [118]. Patogeni koji se uklanjaju su najčešće bakterije ali mogu biti gljivice [2], [107], [113], [119] i mikrotoksini [120]. Tokom procesa dekontaminacije se najčešće koriste gasovi kao što su vazduh, SF₆, He i Ar. Posebno zanimljiv metod dekontaminacije

je izlaganje patogena vazduhu koji se prethodno aktivira prolaskom kroz mikrotalasno pražnjenje [121], [122].

1.4 ZAKLJUČAK

U prvom delu uvoda je dat kratak pregled osnovne teorije vezane za fiziku plazme i objašnjeni su osnovni pojmovi koji će se kasnije koristiti. Obradene su teme vezane za električni proboj, energijske bilanse i mehanizme održavanja pražnjenja, sa posebnim akcentom na pražnjenja naizmenične pobude na niskom pritisku koja su i glavna tema ove disertacije. Pojašnjene su razlike između induktivno i kapacitivno spregnutih plazmi kao i pražnjenja sa niskom i visokom frekvencijom pobudnog signala. Drugi deo uvoda je posvećen dijagnostičkim metodama korišćenim u ovom radu. U delu o masenoj spektrometriji opisan je princip rada različitih vrsta masenih spektrometara i naznačeno je kakav je uređaj korišćen tokom naših merenja. U kratkim crtama su iznete osnove optičke emisije spektrometrije i snimanja ICCD kamerom. Takođe je ukratko opisana Langmirova sonda, njena konstrukcija i teorije koje su neophodne za tumačenje rezultata. U trećem delu je iz širokog polja mogućih primena neravnotežnih plazmi na niskom pritisku izdvojeno i predstavljeno nekoliko tipova primena koje su istražene u okviru disertacije. Za nas su najvažnije primene u tretmanima tekstila i bioloških uzoraka kojima je posvećen i najveći deo trećeg poglavlja uvodne glave.

2. ASIMETRIČNO KAPACITIVNO SPREGNUTO PRAŽNJENJE VELIKE ZAPREMINE

2.1 EKSPERIMENTALNA POSTAVKA

U ovoj glavi će biti opisan asimetrični plazma reaktor velike zapremine. Takođe će biti objašnjeno kako je svaka od dijagnostičkih metoda konkretno primenjena u našem eksperimentu, uključujući njihovu konstrukciju, poziciju u eksperimentu, podešavanja, način prikupljanja i obrade podataka.

2.1.1 ASIMETRIČNI PLAZMA REAKTOR

Asimetrični plazma reaktor velike zapremine je razvijen u Laboratoriji za neravnotežne procese i primene plazme Instituta za fiziku kao prototip uređaja za industrijske primene plazmi u tretmanu osetljivih uzoraka. Cilj konstrukcije je postizanje blažih plazmi i stabilnog pražnjenja u kojem ne bi dolazilo do pojave strimera, koji bi mogli da izazovu oštećenja uzoraka poput tekstila ili semena. Zbog ovih zahteva je odabrana cilindrična geometrija sa jednom centralnom elektrodom. Šema reaktora je prikazana na slici 2.1.1. U laboratoriji su konstruisana dva asimetrična reaktora jednakih geometrija ali različitih dimenzija. Manji reaktor je dugačak 46 cm sa promerom od 37,5 cm dok je veći reaktor dužine 250 cm i promera 117 cm. Osim ukoliko ne bude drugačije naglašeno, u nastavku teksta će se govoriti o velikom reaktoru.

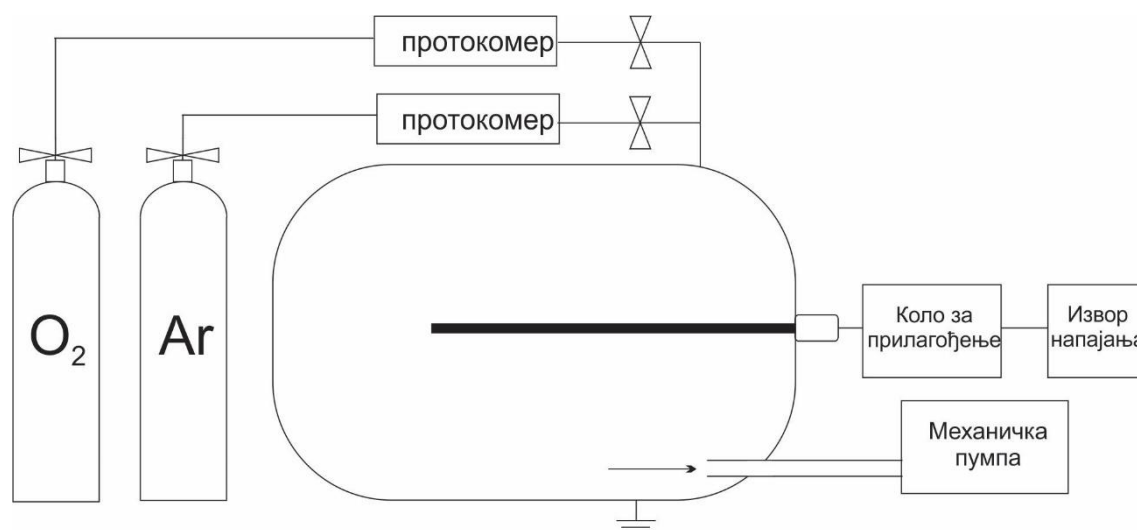

Slika 2.1.1. Šematski prikaz sistema za napajanje (13,56 MHz) i sistema za uvod gasova i kontrolu pritiska asimetričnog reaktora velike zapremine

Napajana elektroda je postavljena aksijalno i napravljena je od aluminijuma. Dugačka je 1,5 m a promer joj je 3 cm. Zid komore, koji je napravljen od nerđajućeg čelika, igra ulogu uzemljene elektrode. Od napajane elektrode je električno izolovan elementima od teflona. Velika razlika u površinama napajane i uzemljene elektrode omogućava stvaranje željenih, blažih, osobina pražnjenja. Dodatna prednost ovakve, izrazito asimetrične, geometrije je ta što se izloženost uzorka fluksu

Asimetrično kapacitivno spregnuto pražnjenje velike zapremine

aktivnih čestica poput jona, elektrona ili radikala u praksi može podešavati pažljivim odabirom pozicije u prostoru između napajane šipke i uzemljenog zida. Na dnu komore, 46 cm ispod napajane elektrode, se nalazi platforma od nerđajućeg čelika. Ona je kvadratnog oblika, dimenzija 65 cm x 65 cm i u električnom je kontaktu sa uzemljenom elektrodom. Tokom tretmana, uzorci se nalaze na ovoj platformi. Kako bi se pristupilo unutrašnjosti komore potrebno je kompletno ukloniti njen prednji deo, koji se nalazi naspramno od mesta na kome u reaktor ulazi napajana elektroda, i težak je više desetina kilograma. Moguće ga je pomerati po nosećoj šini sa njegove gornje strane. Vakuumsko zaptivanje se vrši posebno napravljenim gumenim prstenom.

Za napajanje sistema se koristi RF generator Dressler Cesar 1310. Maksimalna snaga ovog izvora je 1000 W a frekvencija na kojoj radi iznosi 13,56 MHz. Opremljen je i automatskim kolom za prilagođenje tipa Variomatch VM 1000A. Kako bi se transfer snage kroz električni sistem doveo do maksimuma, a time izbeglo nepotrebno zagrevanje i oštećenje sistema, dužina korišćenih kablova ne može biti proizvoljna. U idealnom slučaju bi dužina svih pojedinačnih kablova trebalo da bude jednaka talasnoj dužini na korišćenju frekvenciji, odnosno u našem slučaju 22,12 m. S obzirom da je za laboratorijske uslove ovo nepraktično, u našem slučaju je dužina kabla između izvora i kola za prilagođenje približno jednaka četvrtini talasne dužine dok je dužina kabla između kola za prilagođenje i plazme približno jednaka osmini talasne dužine. Tokom naših merenja reflektovana snaga nikad nije prelazila 2 % poslate a u najvećem broju slučajeva je bila ispod 1 %.

Za vakuumiranje sistema je korišćena Pfeiffer Vacuum DUO 65 mehanička pumpa. Maksimalna brzina vakuumiranja ove pumpe iznosi 70 m³/h. Brzinu pumpanja je moguće podešavati ručnim stepenastim ventilom. Tokom svih merenja ovaj ventil je bio maksimalno otvoren. Pumpa je na komoru povezana preko metalnog tombak creva i KF50 spojeva. Kako bi se unos nečistoća u sistem sveo na minimum, gasovi se uvode preko sistema cevi od nerđajućeg čelika. Kapacitivno merilo za merenje pritiska je postavljeno na komoru sa bočne strane i povezano je preko KF25 spoja. Pritisak u komori se kontroliše i održava kontrolom protoka gasova. Korišćena smeša gasova je sačinjena od 99% kiseonika (O₂) i 1% argona (Ar). Merenja su rađena na pritiscima od 300 mTorr, 450 mTorr i 600 mTorr a njima odgovaraju protoci od 225 sccm, 400 sccm i 580 sccm, respektivno.

Sa bočne strane komore se nalaze prozori prečnika 11 cm, kroz koje se može posmatrati plazma ali se na njih može kačiti i dijagnostička oprema kao što je prikazano na slici 2.1.2.

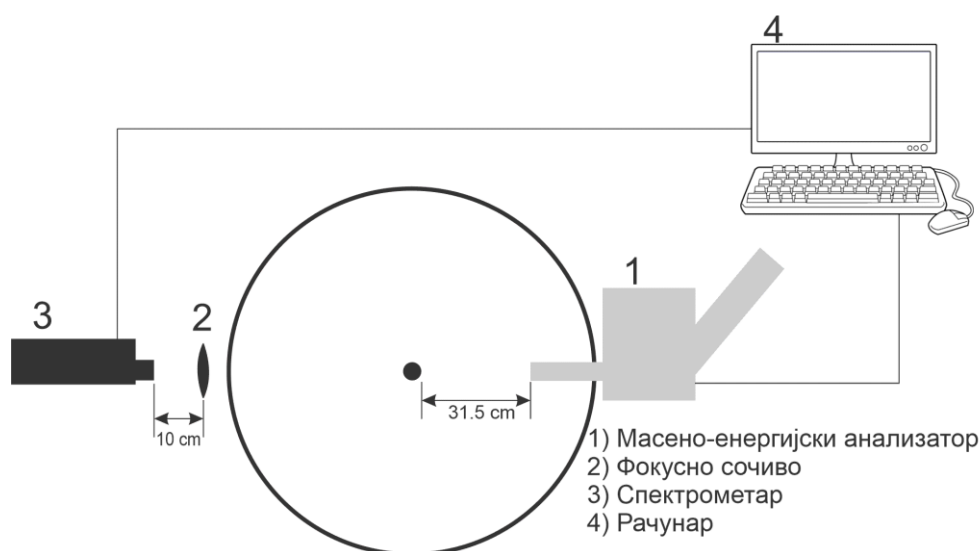

Slika 2.1.2 Šema postavke dijagnostičke opreme na komori asimetričnog reaktora velike zapremine, frontalni prikaz

Asimetrično kapacitivno spregnuto pražnjenje velike zapremine

Kako bi se ispitaio uticaj odnosa površina uzemljene i napajane elektrode na osobine pražnjenja, konstruisana je i dodatna, takođe cilindrična, uzemljena elektroda. Izrađena je od aluminijuma a prečnik je odabran tako da joj se zid nalazi na istom rastojanju od napajane elektrode kao i ulazni otvor maseno-energijskog analizatora. Na njoj su konstruisani i bočni otvori koji su u liniji sa otvorima spoljnog zida komore i omogućavaju nesmetanu dijagnostiku. Prorez koji je napravljen kako bi maseni spektrometar imao pristup pražnjenju je promera 39 mm. Dodatna elektroda je sa prednje i zadnje strane potpuno otvorena a u električnom je kontaktu sa uzemljenim zidom komore kao i sa platformom za postavljanje uzoraka na koju se oslanja preko dva para nožica. Na ovaj način je omogućeno merenje u dve različite konfiguracije uzemljenih elektroda, velikog i malog poluprečnika, a njihov šematski prikaz se vidi na slici 2.1.3.

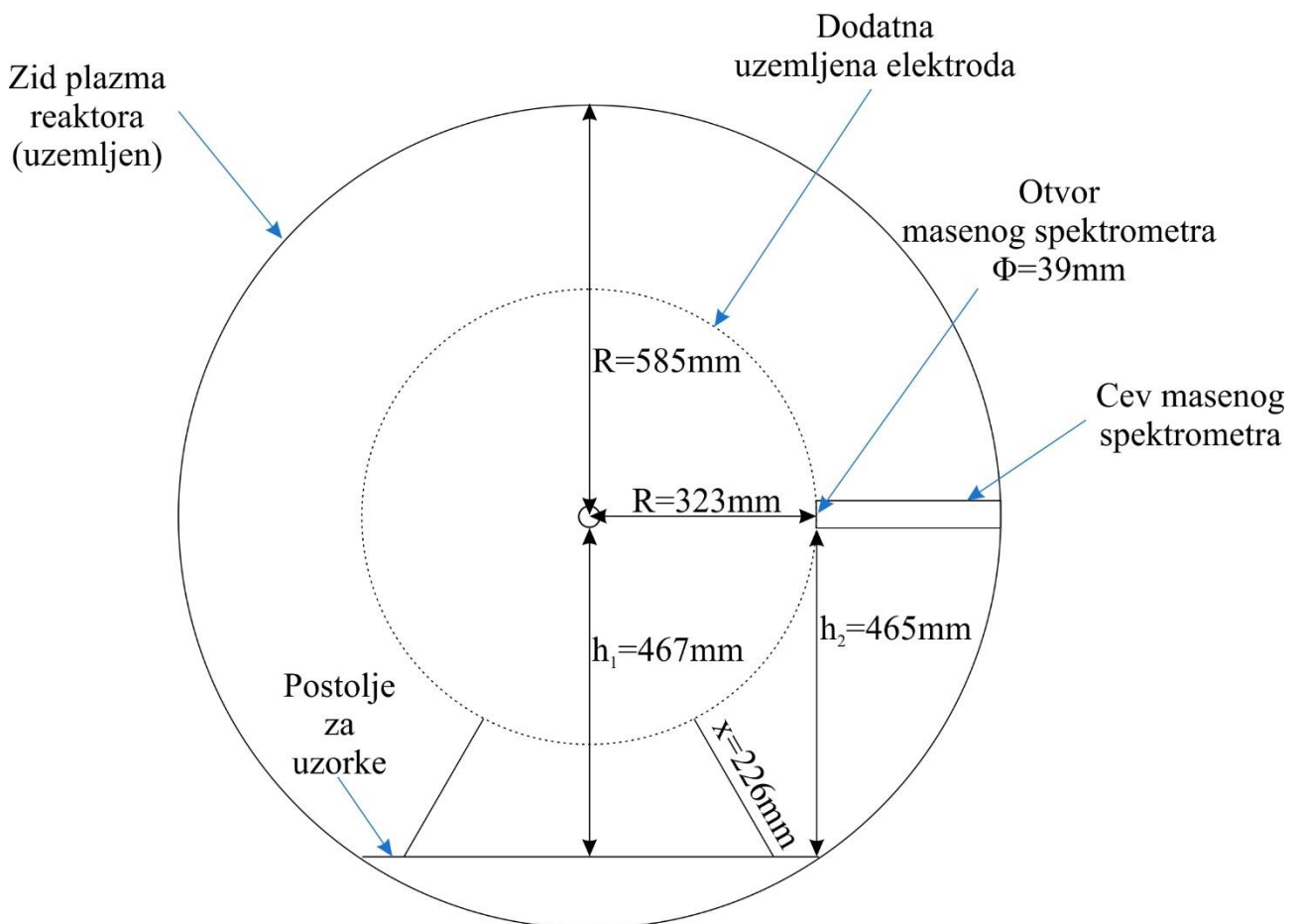

Slika 2.1.3 Šema uzemljenih elektroda sa naznačenom pozicijom masenog spektrometra. Dodatna uzemljena elektroda je obeležena isprekidanom linijom. Na njoj je napravljen otvor promera 39 mm kako bi maseni spektrometar imao pristup plazmi.

2.1.2 DERIVATIVNE SONDE

Derivativne sonde koje smo koristili u svim merenjima struno-naponskih karakteristika pražnjenja su razvijene i napravljene u Laboratoriji za neravnotežne procese i primenu plazme Instituta za fiziku. Njihov šematski prikaz se nalazi na slici 2.1.4 dok je fotografija jedne od izvedbi prikazana na slici 2.1.5. Konstruisane su kao par sonde koje su fiksirane u kutiji kroz koju prolazi napajani vod. Kapacitivna, odnosno, naponska sonda je napravljena u obliku slova T dok je

Asimetrično kapacitivno spregnuto pražnjenje velike zapremine

induktivna strujna sonda napravljena u obliku kalema. Napon na kapacitivnoj sondi je proporcionalan izvodu napona kroz vod i iznosi $V_c = RC \frac{dV}{dt}$ dok napon na induktivnoj sondi zavisi od promene struje i može se predstaviti kao $V_i = L \frac{dI}{dt}$. Signali se preko BNC ili SMA konektora i koaksijalnih kablova prenose do osciloskopa gde se snimaju radi dalje obrade. Prilikom konstrukcije je potrebno voditi računa o tome da otpornost sistema derivativnih sondi bude 50Ω i da vremenske konstante (RC odnosno L/R) budu manje od glavnog perioda napajanja odnosno od 73,7 ns. Povezivanje kutije sa sondama sa komorom za pražnjenje i izvorom snage se vrši preko UHF ili N konektora. U našim merenjima su korišćeni BNC konektori za povezivanje sa osciloskopom i N konektori za povezivanje kutije sa napajanjem. Podaci su prikupljeni Tektronix MDO3014 osciloskopom. Snimano je 100.000 tačaka a svako merenje je bilo usrednjeno 128 puta.

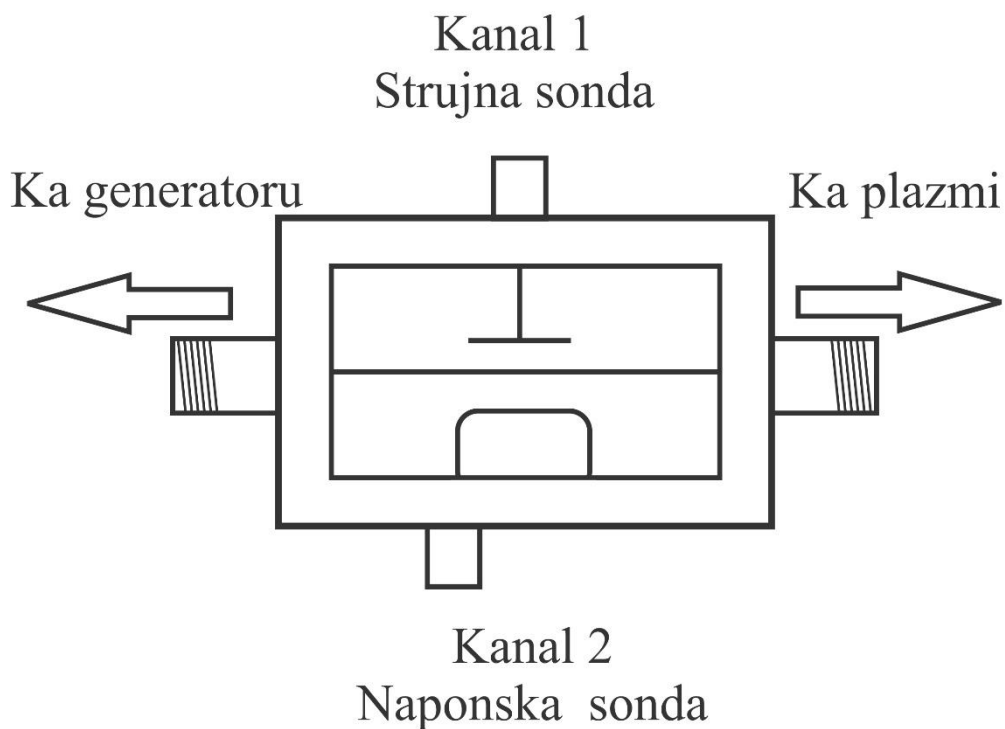

Slika 2.1.4 Šematski prikaz derivativnih sondi

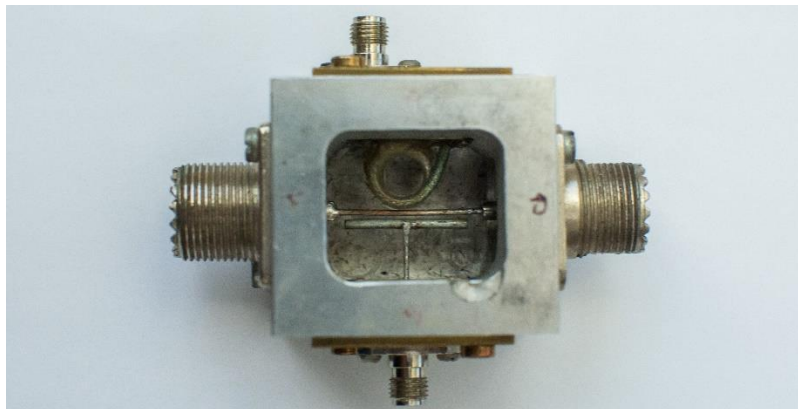

Slika 2.1.5 Fotografija jedne od izvedbi derivativnih sondi

Asimetrično kapacitivno spregnuto pražnjenje velike zapremine

Pre upotrebe u laboratoriji sonde je potrebno kalibrisati i u tu svrhu se koristi mrežni analizator (*eng* Network analyzer). Na intenzitet i oblik dobijenog signala utiče blizina sonde napajanom vodu, dužina kablova i geometrija kutije. Poželjno je da sonde budu što bliže napajanom vodu zbog jače sprege i prilikom konstrukcije treba voditi računa o tome da sprega između strujne i naponske sonde bude minimalna. Kutija derivativnih sonde je zatvorena kako bi se spoljašnje smetnje sveli na minimum. S obzirom na to da dužina signalnih kablova bitno utiče na kašnjenje signala, odnosno na njegovu fazu, ovi kablovi moraju da budu iste dužine. Takođe je potrebno da se izvrši kalibracija oba kabla sa setom sonde uz koje će da se koriste.

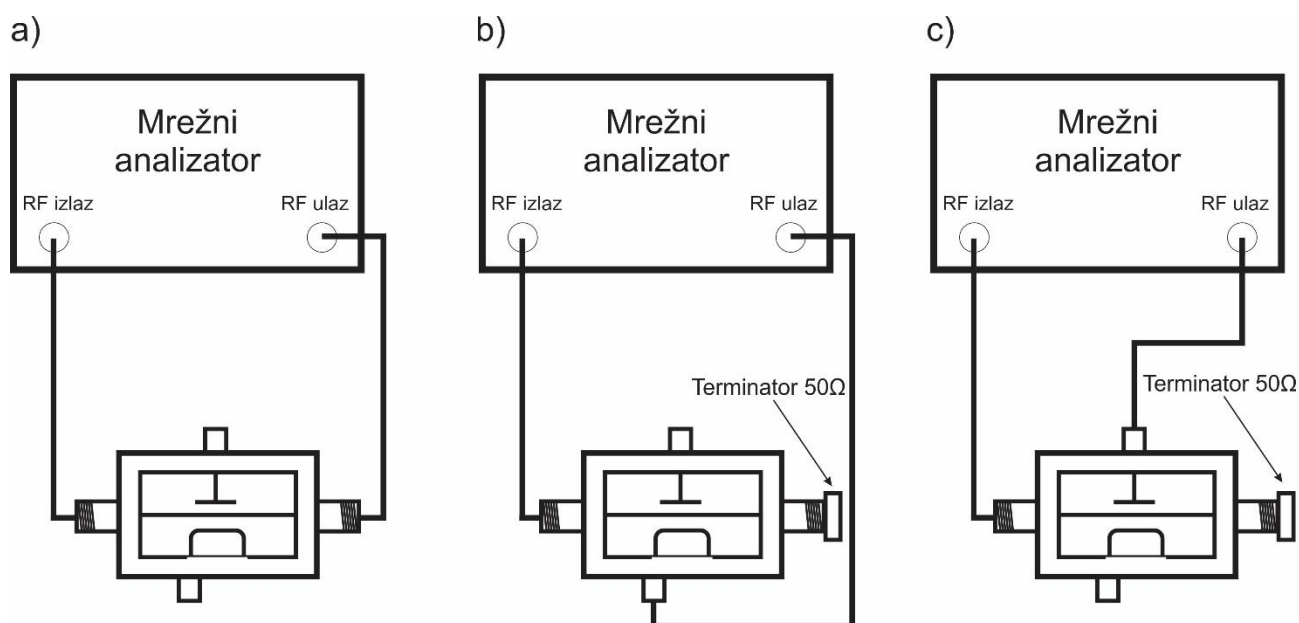

Slika 2.1.6 Postupak kalibracije derivativnih sonde a) mere se vrednosti na centralnom vodu odnosno na napajanoj elektrodi, referentni signal, a zatim se mere odzivi b) strujne i c) naponske sonde.

Tokom kalibracije je potrebno uporediti referentni signal sa signalima na strujnoj i naponskoj sondi. Referentni signal se dobija povezivanjem kutije sa sondama na mrežni analizator tako što se ulaz kutije poveže na izlaz analizatora, dok je izlaz kutije povezan sa ulazom analizatora kao što je prikazano na slici 2.1.6 a). Da bi se zatvorilo kolo, tokom merenja strujnog i naponskog signala na sondama se na izlaz iz kutija postavlja otpornik od 50 Ω . Odziv sonde na poznatu pobudu se zatim dobija tako što se isti pobudni signal pušta kroz kutiju dok se izlazi sonde povezuju sa ulazom mrežnog analizatora kao što je prikazano na slici 2.1.6 b) i c). Kako bi se gubici snage nakon tačke merenja sveli na minimum, nakon kalibracije, sonde je tokom merenja poželjno postaviti što bliže pražnjenju. U našoj postavci, sonde su bile povezane direktno sa napajanom elektrodom.

Asimetrično kapacitivno spregnuto pražnjenje velike zapremine

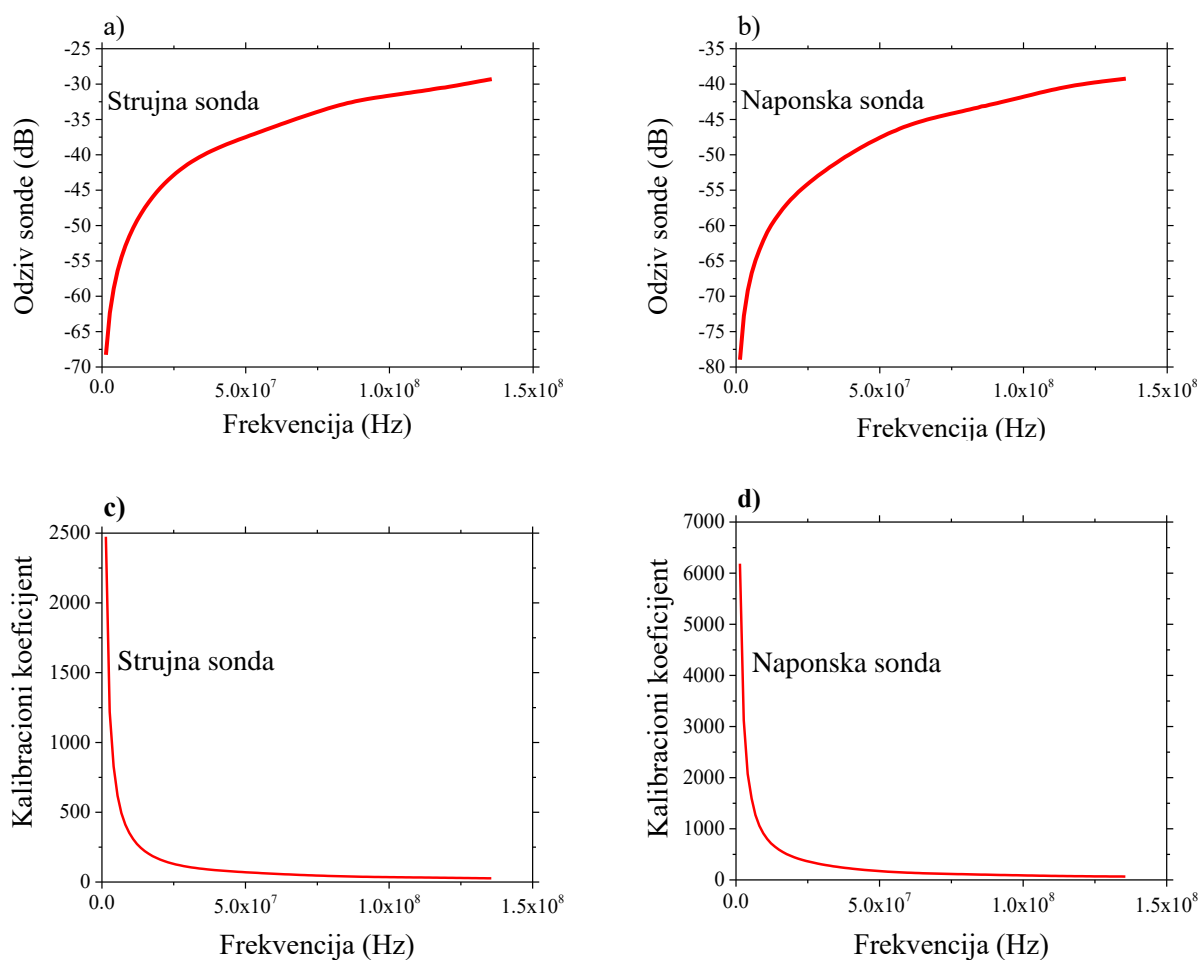

Slika 2.1.7 Odzivi a) strujne i b) naponske sonde u odnosu na signal poznatog intenziteta i odgovarajući kalibracioni koeficijenti c) strujne i d) naponske sonde.

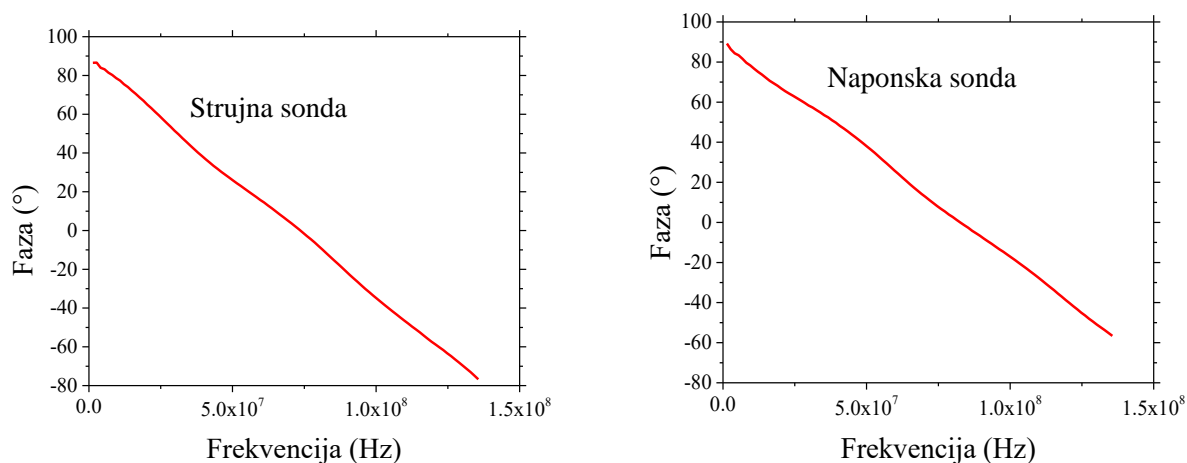

Slika 2.1.8 Kalibracione krive za faznu korekciju signala a) strujne i b) naponske sonde

Signale koji se dobiju tokom merenja direktno sa osciloskopa je potrebno korigovati dobijenim kalibracionim krivama. Odzivi strujne i naponske sonde su prikazani na slikama 2.1.7 a) i b) dok su kalibracioni koeficijenti u zavisnosti od frekvencije prikazani na slikama 2.1.7 c) i d). Fazna kalibraciona kriva je za strujnu sondu prikazana na slici 2.1.8 a) a za naponsku na slici 2.1.8 b). Za

Asimetrično kapacitivno spregnuto pražnjenje velike zapremine

obradu signala je korišćena Matlab skripta. Direktно izmereni struja i napon, koji zavise od vremena, se Furijeovom transformacijom (eng. Fast Fourier Transform - FFT) prebacuju u frekventni domen. Oni se zatim koriguju u skladu sa amplitudnim i faznim kalibracionim krivama. Nakon toga se inverznom Furijeovom transformacijom (eng. Inverse Fast Fourier Transform - IFFT) vraćaju u vremenski domen. Ovako dobijeni signali se sada, množenjem integrala struje i napona, mogu koristiti za dobijanje snage pražnjenja.

2.1.3 MASENO ENERGIJSKI ANALIZATOR

Za maseno-energijsku analizu pražnjenja korišćen je komercijalno dostupan sistem EQP Analyser firme Hiden Analytical čiji je šematski prikaz predstavljen na slici 2.1.9. U komoru je postavljen bočno tako da je njegov ulazni otvor okrenut prema napajanoj elektrodi. Isporučuje se sa tri nastavka pomoću kojih je moguće menjati širinu otvora za uzorkovanje čestica na 50 μm , 100 μm ili 300 μm . U našim merenjima je korišćen otvor promera 50 μm .

Pre nego što se počne sa radom potrebno je sačekati da pritisak u masenom analizatoru bude manji od $5 \cdot 10^{-6}$ Torr. Za postizanje vakuuma, sistem je opremljen turbo-molekularnom pumpom Edwards EXT75DX uz podršku dvostepene rotirajuće pumpe, dok se za merenje pritiska koristi merilo sa hladnom katodom.

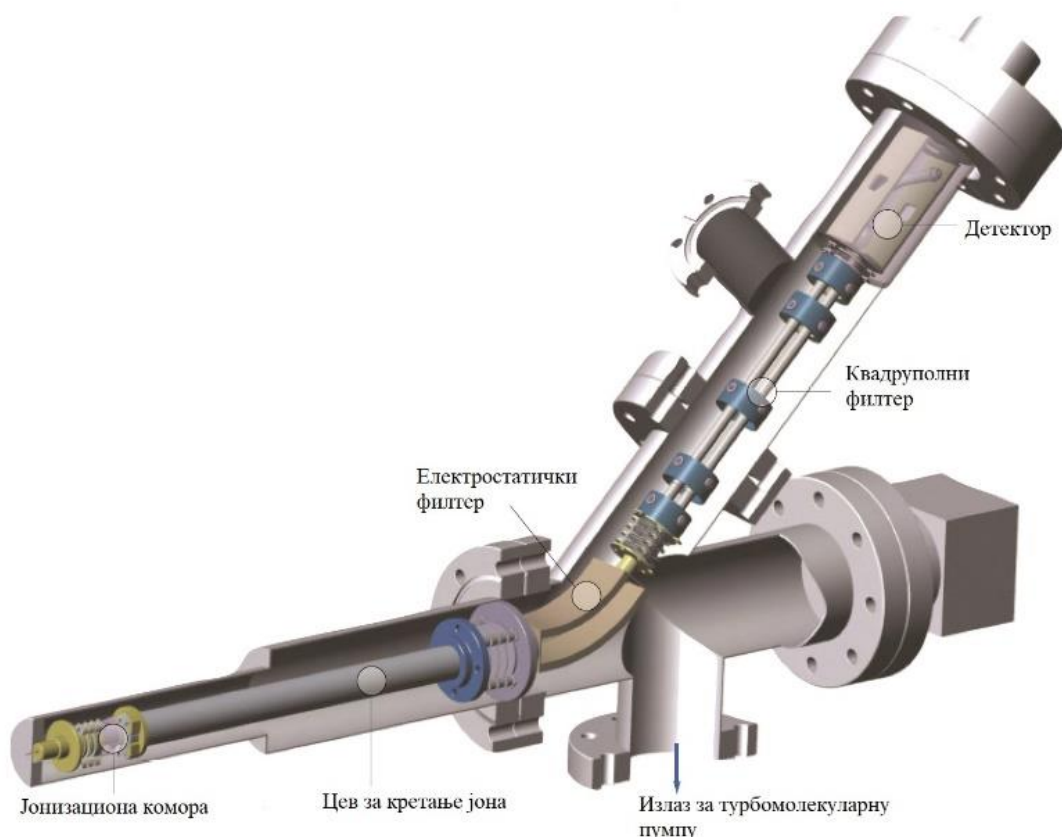

Slika 2.1.9 Šema maseno-energijskog analizatora (www.hidenanalytical.com)

Kako bi omogućio merenje različitih osobina čestica ovaj sistem koristi veći broj elektroda i elektro-magnetnih sočiva koja su grupisana u pet celina: ekstrakcija, izvor, sektor, kvad (quad) i

detektor. Na slici 2.1.9 je prikazana šema maseno-energijskog analizatora, koja je preuzeta sa internet stranice proizvođača. Na njoj su naznačeni najvažniji delovi uređaja ali oni nisu razvrstani po pomenutim celinama. Grupa elektroda koja se zove ekstrakcija se nalazi na samom ulaznom otvoru masenog spektrometra. Nju je moguće aktivirati samo tokom merenja nad naelektrisanim česticama. Iako to nije neophodno ukoliko je signal dovoljno veliki, na ove elektrode može da se dovede napon kako bi se dodatno privukli joni jedne vrste (na primer negativni) a odbili suprotno naelektrisani (na primer pozitivni). Sledeća grupa, izvor, aktivna je samo tokom merenja nad neutralnim česticama. Unutar nje se vrši jonizacija neutrala radi dalje analize. U grupi koja se zove sektor se nalazi cev za kretanje jona (*eng* drift tube) i elektrostatički filter po energijama. Filtriranje čestica po odnosu mase i naelektrisanja (m/Z) se vrši u grupi pod imenom kvad čiji je najvažniji deo kvadrupolni filter. Brojanje čestica se vrši u grupi pod nazivom detektor u kome glavnu ulogu ima SEM (*eng* Secondary Electron Multiplier) odnosno multiplikator sekundarnih elektrona. Različitim podešavanjima sistema sočiva i filtera merenje se može vršiti nad pozitivnim, negativnim ili neutralnim česticama. Moguće je dobiti i raspodelu jona ili neutrala po energijama a posebno korisna opcija je mogućnost kontrole energije jonizujućih elektrona.

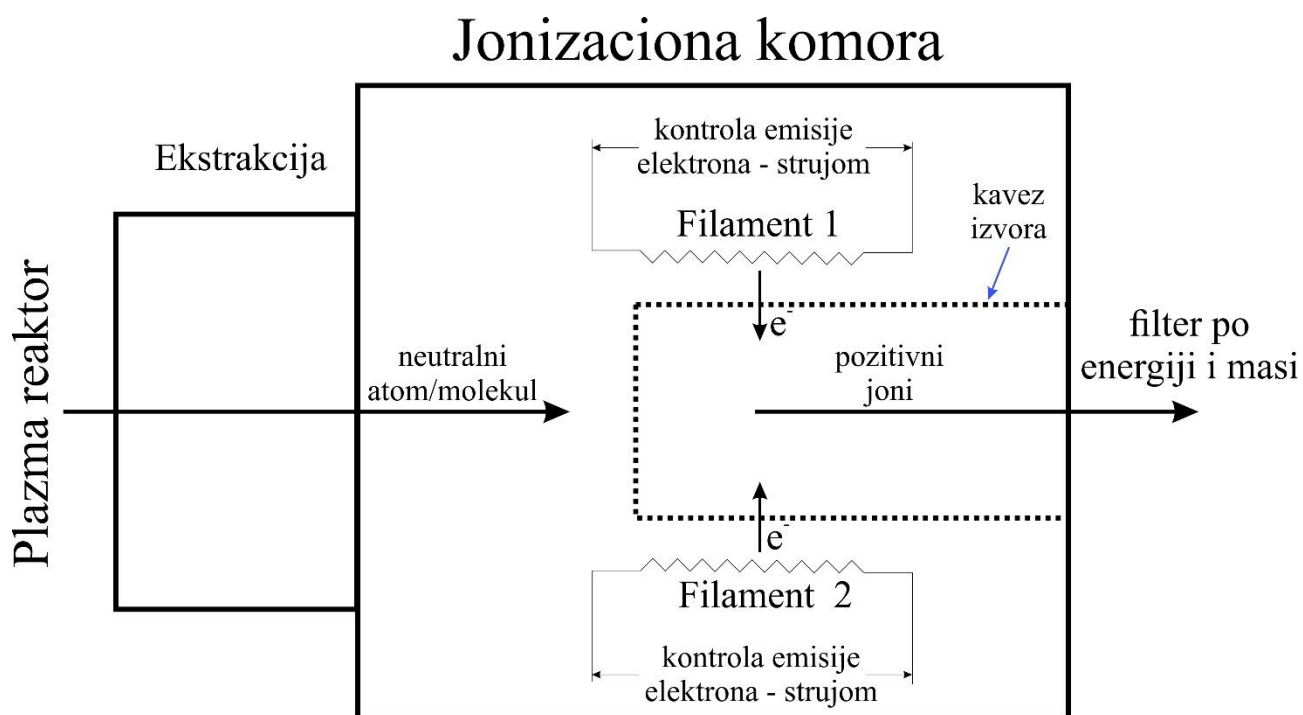

2.1.10 Šematski prikaz jonizacione komore maseno-energijskog analizatora sa naznačenim putem neutralnih čestica od plazma reaktora ka filteru po energiji i masi.

Čestice koje se analiziraju mogu na dva načina da dođu do mesta na kome maseno-energijski analizator vrši njihovo uzorkovanje, odnosno do njegovog ulaznog otvora. Naelektrisane čestice će prema otvoru biti usmerene skupom elektroda i sočiva, koje pripadaju grupi ekstrakcija, dok će neutralne čestice do te pozicije stići difuzijom iz plazme. Tokom merenja nad neutralnim česticama sistem mora da se ubaci u RGA režim (*eng* Residual Gas Analysis). S obzirom na to da je manipulacija nad neutralnim česticama praktično nemoguća, njih je nakon ulaska u analizator potrebno jonizovati kako bi dalja merenja i analize uopšte bile izvodljive. Jonizacija se obavlja u jonizacionoj komori, čija je šema prikazana na slici 2.1.10, sudarom neutrala i elektrona velike energije. Kao izvor elektrona se koristi užareno vlakno, dok se njihova energija kontroliše podešavanjem napona između samog vlakna i kaveza izvora (*eng* source cage). Drugim rečima, ukoliko je potrebno da se neutral sudari sa elektronom energije od, na primer, 20 eV napon između

užarenog vlakna i kaveza izvora će biti podešen na 20 V. Dodatno, moguće je podešavati i ukupan broj elektrona koji se od užarenog vlakna kreće ka kavezu izvora, što se postiže promenom vrednosti struje filameta. Vrednost ove veličine može da se podešava u opsegu od 20 μA do 5000 μA . U našim eksperimentima su korišćene vrednosti od 20 μA i 100 μA . Sistem raspolaže sa dva vlakna koja se mogu koristiti istovremeno ali je tokom naših merenja u upotrebi bilo samo jedno od njih. Naglasićemo ponovo da je jonizaciona komora aktivna samo tokom merenja nad neutralima, odnosno u RGA režimu. Situacija je nešto drugačija kada se merenja obavljaju nad česticama koje su naelektrisane. Tokom analize jona sistem mora da bude u SIMS+/- režimu (*eng* Secondary Ion Mass Spectrometry). Za pozitivne jone se koristi SIMS+ a za negativne SIMS-. Ukoliko se merenje vrši nad pozitivnim jonima (SIMS+), elektronska sočiva i elektrode iz grupe ekstrakcija će biti podešena tako da se pozitivni joni usmeravaju ka ulaznom otvoru analizatora dok će prolaz negativnim jonima biti onemogućen. Za merenje nad negativno naelektrisanim česticama (SIMS-), podešavanja će biti obrnuta. Dok je sistem u SIMS režimu, naelektrisane čestice se ekstrakcionim sočivima fokusiraju kroz neaktivnu jonizacionu komoru direktno na njen izlazni otvor. Nakon ove tačke se joni, bez obzira na to da li su nastali u samom masenom spektrometru ili su prikupljeni iz plazme, usmeravaju prema filteru po energijama, kvadrupolu, i na kraju prema detektoru.

Maseni spektri se u literaturi najčešće prikazuju kao doprinosi na određenim vrednostima m/Z [20], [25], [123] ili, nešto ređe, kao odbroji u zavisnosti od m/Z [124]–[126]. Doprinosi se računaju po sledećoj formuli:

$$Y_i = \frac{n_i}{\sum_{i=1}^{50} n_i} * 100\%. \quad (2.1)$$

gde je sa Y_i obeležena i -ta vrsta čiji se doprinos računa dok je sa n_i obeležen odbroj i -te vrste. Dobijeni rezultati se predstavljaju u procentima ukupno izbrojanih čestica.

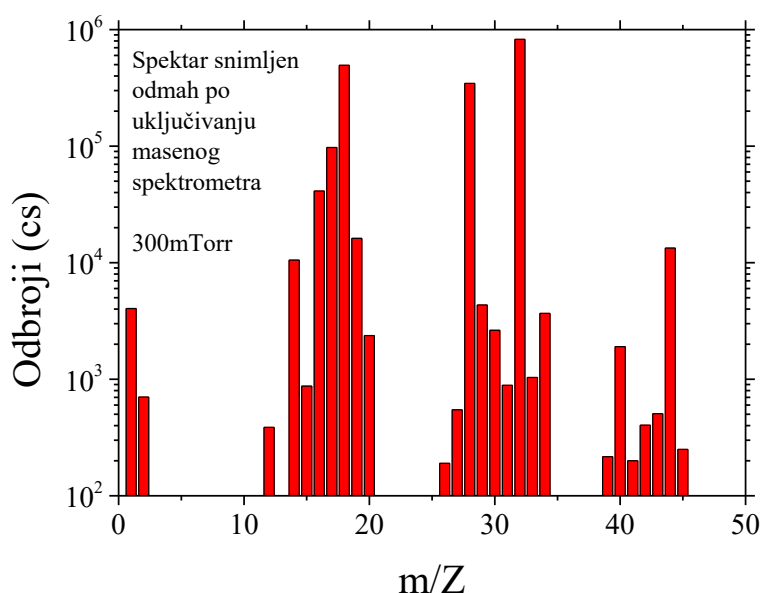

Slika 2.1.11 Maseni spektar koji snimljen čim je pritisak u spektrometru spušten ispod $5 \cdot 10^{-6}$ Tor, odnosno na početku procedure uklanjanja nečistoća iz reaktora.

Za vakuumiranje komore za pražnjenje korišćena je mehanička pumpa (Pfeiffer Vacuum DUO 65) tako da je bilo očekivano i prisustvo određenih nečistoća u masenom spektru. Pored primesa poput ugljen dioksida, čiji prisustvo nije veliko, u sistemu se pojavljuje azot, koji dolazi iz okolne

atmosfera i voda. Zbog toga je bilo potrebno osmisliti proceduru čijom bi se primenom smanjili efekti nečistoća i osigurala reproducibilnost merenja. Priprema celog sistema pre sistematskih merenja se sastoji od sledećih nekoliko koraka. Sistem se vakuumira dok pritisak ne opadne do vrednosti najmanjeg pritiska na kojem će se vršiti merenje, odnosno do 300 mTorr. Nakon postizanja tog pritiska u sistem se upuštaju kiseonik (99%) i argon (1%) na protocima koji će pritisak da održavaju konstantnim i sistem se u takvom, protočnom, stanju ostavlja dva sata. Maseni spektrometar se uključuje čim pritisak u njemu opadne ispod $5 \cdot 10^{-6}$ Torr. Na slici 2.1.11 je prikazan jedan spektar koji snimljen baš u tom trenutku. Jasno je vidljivo prisustvo pomenutih nečistoća. Tokom sledećih dva sata se u realnom vremenu prate odbroji vrsta koje su važne za merenje, poput kiseonika i argona, i vrsta koje su na početku ovog perioda izmerene sa velikim odbrojima a koje su prepoznate kao nečistoće, poput vode i azota. Jedan primer njihove evolucije je dat na slici 2.1.12.

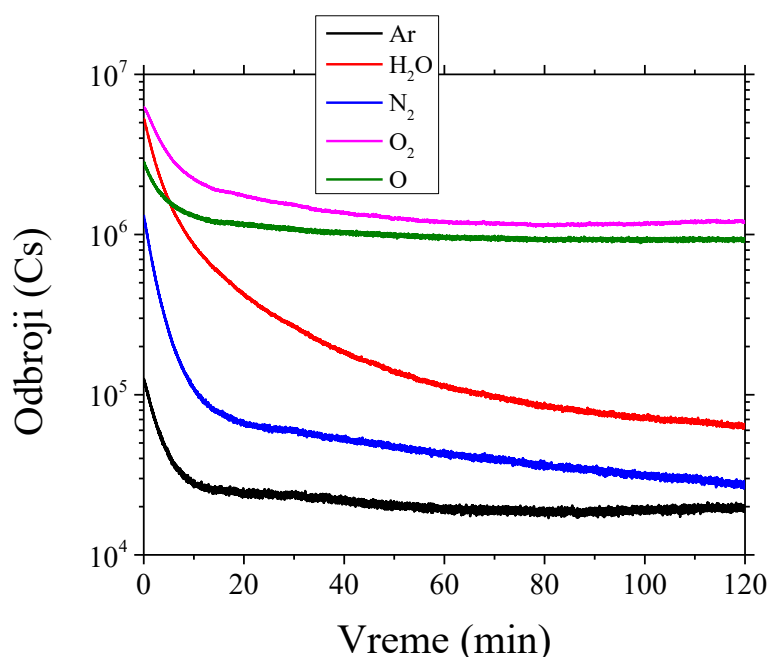

2.1.12 Evolucija odbroja karakterističnih jona i neželjenih primesa u sistemu, poput azota i vode, tokom pripreme za merenje na pritisku od 300 mTorr bez uključenog pražnjenja u komori.

Važnost pripreme sistema pre svakog merenja može da se vidi kroz masene spektre prikazane na slikama 2.1.13 i 2.1.14. U oba slučaja su predstavljeni spektri snimljeni odmah po uključivanju masenog spektrometra i nakon dva sata protočnog režima. Korišćene su dve energije elektrona za jonizaciju, 70 eV (standardno korišćena energija u masenoj spektrometriji) i 20 eV.

Maseni spektri koji su snimljeni sa energijom jonizujućih elektrona od 70 eV po uključivanju masenog spektrometra i nakon dva sata protočnog režima su prikazani na slici 2.1.13. Slika 2.1.13 a) prikazuje maseni spektar u odbrojima a slika 2.1.13 b) pomoću doprinosa. Spektri koji su snimljeni odmah po uključivanju masenog spektrometra su prikazani punim crvenim linijama dok su šupljim crnim linijama označeni spektri koji su dobijeni posle dva sata protočnog režima. Pre početka procedure za uklanjanje nečistoća odbroji vode i molekularnog azota su bili istog reda veličine. Preračunato u doprinose u ukupnom spektru molekularni kiseonik je imao udeo od 44 % dok su voda i azot činili 26 % i 18 %. Drugim rečima, njihov zajednički doprinos je bio identičan doprinosu kiseonika. Plazma koja bi nastala uključivanjem pražnjenja u komori sa ovakvom smešom gasova bi u značajnoj meri sadržala atome azota, N_2^+ i N^+ jone ali i jone i radikale koji su nezaobilazni kada u pražnjenju postoji voda poput H^+ , H_3O^+ ili OH^+ . Kompletan plazma hemija bi u takvom slučaju bila značajno drugačija od one koja bi postojala u plazmi u kojoj se nalazi 99 % O_2 i 1 % Ar. Dodatni

problem nastaje zbog činjenice da su kontrolisani protoci kiseonika i argona mnogo veći od količine azota i vode koji u komoru ulaze u istoj jedinici vremena, što znači da će se i sastav smeše neminovno menjati s protokom vremena. Zbog ovih problema je i osmišljena procedura koja obezbeđuje da sastav smeše u velikoj meri odgovara ciljanom, iako je prisustvo određenih primesa nemoguće potpuno odstraniti, a obezbeđena je i reproducibilnost sastava tokom ponovljenih merenja. Nakon 2 sata protočnog režima odbroji primesa su opali u tolikoj meri da doprinos molekuskog kiseonika u ukupnom masenom spektru iznosi 83 % dok su doprinosi azota i vode pali ispod 1 % i 4 %.

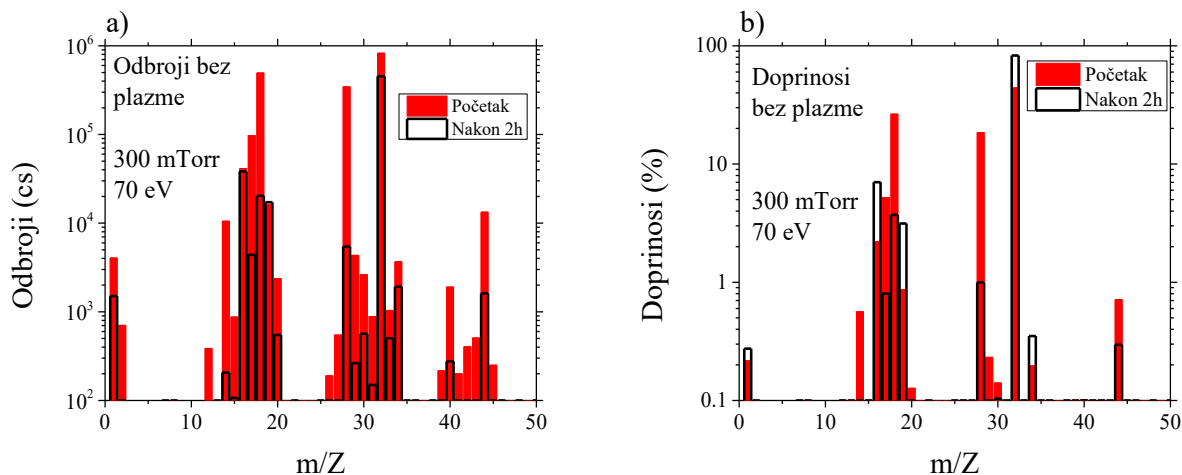

Slika 2.1.13 Spektri neutrala koji su snimljeni na 300 mTorr na početku i na kraju procedure pripreme sistema za merenje sa energijom jonizujućih elektrona od 70 eV predstavljeni preko a) odbroja i b) doprinosa.

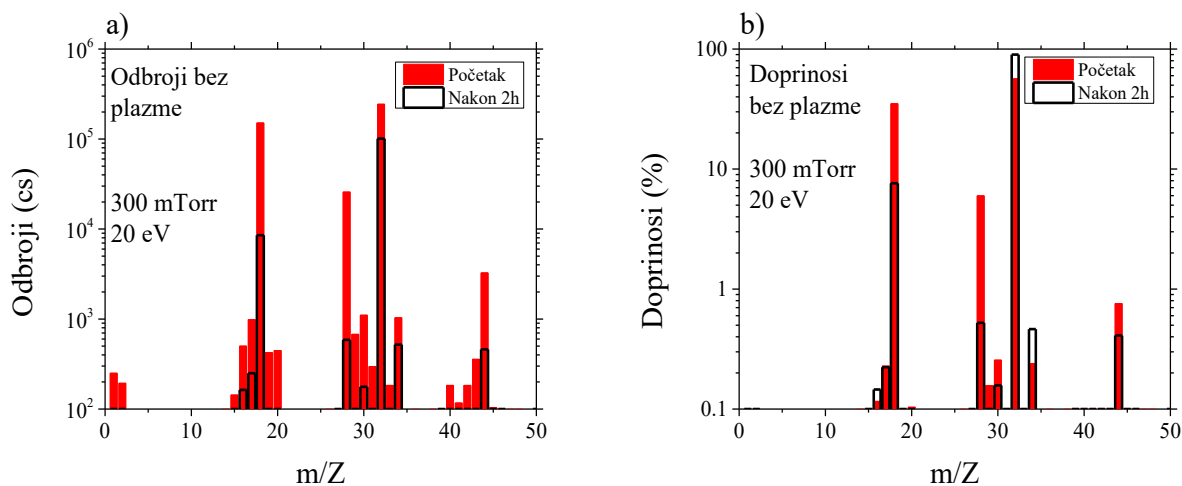

Slika 2.1.14 Spektri neutrala koji su snimljeni na 300 mTorr na početku i na kraju procedure pripreme sistema za merenje sa energijom jonizujućih elektrona od 20 eV predstavljeni preko a) odbroja i b) doprinosa.

Maseni spektri koji su snimljeni sa energijom jonizujućih elektrona od 20 eV odmah po uključivanju masenog spektrometra i nakon dva sata protočnog režima su prikazani slikama 2.1.14 preko a) odbroja i b) doprinosa. S obzirom da je energija elektrona značajno niža, u ovim spektrima će, u poređenju sa onima predstavljenim na slici 2.1.13, ukupni odbroji biti nešto niži, jer je jonizacija

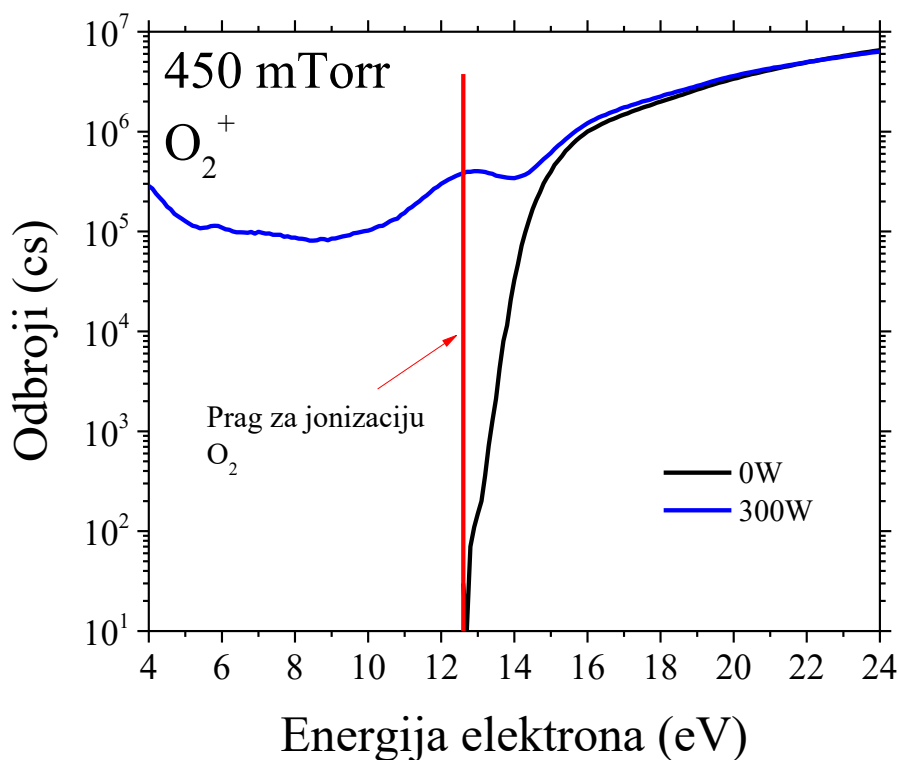

2.1.16 Odbroji molekula kiseonika u zavisnosti od energije jonizujućih elektrona snimljeni bez uključenog pražnjenja i na snazi od 300 W p=450 mTorr

Iako je ovu metodu moguće koristiti za merenje konkretnih pobuđenih stanja [34], sa raspoloživom opremom mi nismo u mogućnosti da pravimo razliku među njima ali možemo da izmerimo njihovo kumulativno dejstvo. Kako bismo to uradili potrebno je maseni spektrometar postaviti u režim za merenje neutralnih čestica (RGA), izabrati odnos m/Z za odgovarajuću vrstu i izmeriti odbroje kao funkciju od energije jonizujućih elektrona. Na slici 2.1.16 su prikazani primeri dve ovakve krive koje su dobijene tokom merenja za m/Z koji odgovara molekulu kiseonika (32).

Kao što je napomenuto, neutralne čestice ne mogu biti analizirane masenim spektrometrom. Zbog toga se u jonizacionoj komori one sudaraju sa elektronom čija je energija veća od praga za jonizaciju. U slučaju molekula kiseonika postoji određeno neslaganje između različitih autora oko vrednosti prvog jonizacionog potencijala. Po podacima koji su dostupni u NIST-ovoj bazi podataka [127], [128] publikovane vrednosti se kreću između 12 eV i 12,8 eV. Vrednost koja se slaže sa našim eksperimentalnim podacima a prijavljena je i od strane drugih autora [129] je 12,6 eV. Kada je pražnjenje u komori isključeno, detekcija neutralnih čestica postaje moguća samo ukoliko je energija jonizujućeg elektrona dovoljna da neutral pretvori u jon, odnosno ukoliko je ona veća od praga za jonizaciju. Jedan primer zavisnosti odbroja od energije jonizujućih elektrona tokom merenja molekulskog kiseonika, bez uključenog pražnjenja u reaktoru, je prikazan crnom bojom na slici 2.1.16. Međutim, kada je pražnjenje uključeno, u plazmi se događaju mnogobrojni procesi kojima se energija predaje neutralnim vrstama. U samom molekulu ta energija može da bude sačuvana u obliku metastabilnog ili nekog drugog pobuđenog stanja. Ovakve čestice je moguće jonizovati i ukoliko je energija elektrona znatno manja od praga za jonizaciju. Zavisnost odbroja O₂ molekula od energije elektrona koja snimljena tokom pražnjenja na snazi od 300 W je prikazana plavom bojom na slici 2.1.16. Za razliku od odbroja koji su predstavljeni crnom linijom, vrlo intenzivan signal postoji i za energije elektrona koje su manje od praga za jonizaciju. Što se tiče energije jonizacije za atom kiseonika, slaganje između autora je značajno bolje. Iako se publikovane vrednosti kreću od 13 eV do 14 eV [130], [131], većina autora se slaže da se ona nalazi na 13,6 eV [132], [133], što je vrednost koju smo i mi koristili. Metoda masene spektrometrije praga za jonizaciju se primenjuje tako što se

Asimetrično kapacitivno spregnuto pražnjenje velike zapremine

od ukupnog broja detektovanih čestica koje su izmerene tokom pražnjenja na određenoj snazi oduzima signal, odnosno ukupan broj čestica, koji je izmeren kada plazma u reaktoru nije bila uključena. Kako ni u jednom našem merenju koje je rađeno bez plazme u komori ne postoji signal ispod praga za jonizaciju, u obzir se uzimaju samo atomi ili molekuli koji su dobijeni tokom merenja sa uključenom plazmom. Ukupan broj pobuđenih čestica koje su došle do otvora masenog-energijskog analizatora dobija se integracijom krive, poput one koja je plavom linijom predstavljena na slici 2.1.16, od minimalne energije na kojoj je moguće vršiti merenje do praga za jonizaciju. Sa našom opremom, minimum energije jonizujućih elektrona iznosi 4 eV. Ovakvim odabirom graničnih uslova za integraciju se izbegava računanje atoma ili molekula, odnosno njihovih jona, koji su nastali jonizacijom iz osnovnog stanja. Takođe, s obzirom na to da se integracija pobuđenih atomskih vrsta vrši do energije od 13,6 eV izbegnuto je i računanje atoma koji nastaju disocijativnom jonizacijom molekula prilikom sudara sa elektronom. Energijski prag za ovu reakciju iznosi 23 eV [129]. Primenom ove metode nije moguće dobiti apsolutne koncentracije pobuđenih vrsta ali se dobija kvalitativan opis pražnjenja koji je veoma važan za primene u tretmanima osetljivih uzoraka.

2.1.5 OPTIČKA EMISIONA SPEKTROSKOPIJA I AKTINOMETRIJA

Za dobijanje optičkih spektara je korišćen Oriol MS127i spektrometar uparen sa Andor iStar ICCD (*eng* Image Intesifier Charge Coupled Device) DH734I kamerom kao detektorom.

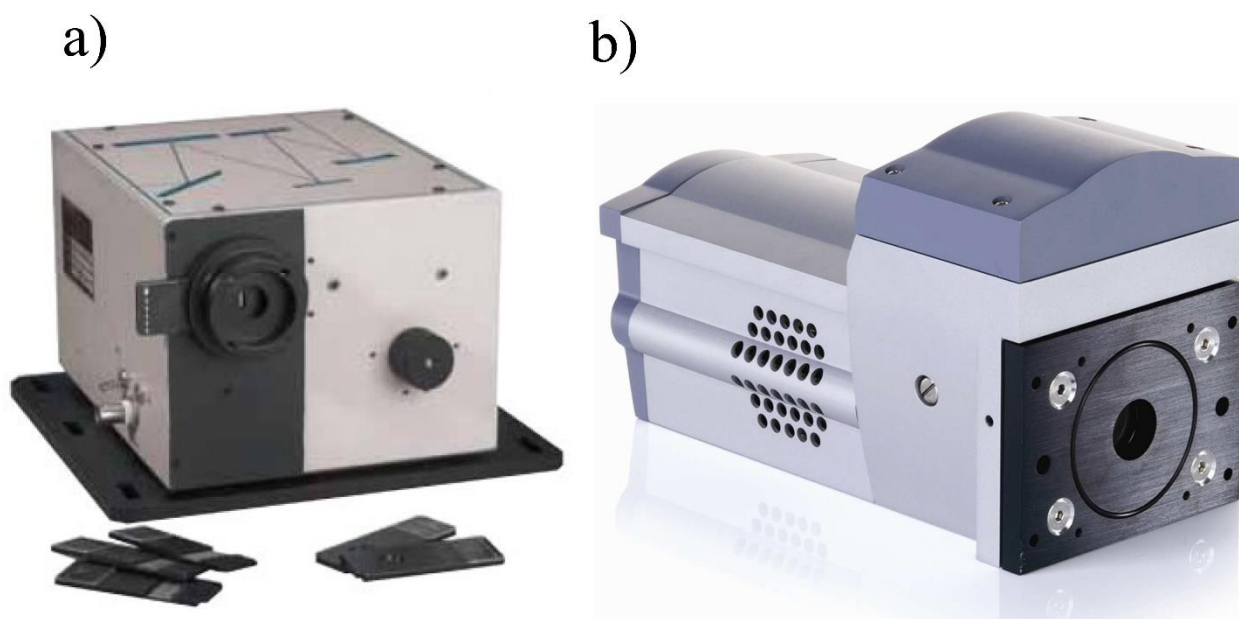

Slika 2.1.17 Spektroskopski sistem koji je sačinjen od a) Oriol MS127i spektrometra i b) Andor iStar ICCD kamere.

Spektrometar ima ulaznu žižnu daljinu od 127 mm dok mu je izlazna žiža 138,5 mm. U zavisnosti od toga koja se difrakciona rešetka koristi, opseg talasnih dužina je između 180 nm i 25 μm . Maksimalna rezolucija koja se sa njim može postići je 0,22 nm. Broj proreza korišćene difrakcione rešetke je 1200 mm^{-1} . Opseg talasnih dužina rešetke se definiše kao oblast u kojoj njena efikasnost ne pada ispod 20 % što u našem slučaju znači da se može koristiti između 200 i 1200 nm.

Prilikom pravljenja snimka potrebno je odabrati vrednost napona na mikrokanalnoj ploči. Sa opremom i korisničkim softverom koji smo koristili to se radi odabirom vrednosti parametra „gain“.

Asimetrično kapacitivno spregnuto pražnjenje velike zapremine

Ova veličina može da bude između 0, što znači da je napon 0, i 255, što znači da se mikrokanalna ploča nalazi na maksimalnom naponu. Radi pojačanja intenziteta detektovanog zračenja Andor iStar ICCD kamera je korišćena u režimu akumulacija. Mi smo koristili softverski režim u kome se vrednosti signala očitavaju pomoću Andorovog programa, pohranjuju na računar a čip se nakon toga vraća u početno stanje. Zatim se pravi novi snimak čije se vrednosti sabiraju sa prethodno sačuvanim. Postupak se može ponavljati proizvoljan broj puta a vreme ekspozicije koje smo koristili za pojedinačni snimak iznosi 300 ms. Rezolucija čipa je 1024x1024 piksela. Iako se čip nalazio na niskoj temperaturi, određeni termalni šum ipak postoji. On se može oduzeti u kontrolnom softveru tako što se napravi jednak snimak kada do senzora ne dolazi nikakva svetlost.

Tokom spektroskopskih merenja, Andor iStar ICCD kamera je bila podešena na sledeće vrednosti:

- Temperatura čipa: -10 °C
- Pojačanje (gain): 100
- Broj akumulacija: 50.

Kako bi dodatno povećali količinu svetlosti koja dolazi do spektrometra, ispred njega je stavljeno sabirno sočivo žižne daljine 10 cm (Slika 2.1.19). Snimanja su obavljanja na tri specifične pozicije:

- Sa prednje strane u nivou napajane elektrode gde je emisija najintenzivnija (pozicija 2).
- Sa prednje strane u nivou platforme za uzorke, 40 cm ispod napajane elektrode (pozicija 1). Na ovoj poziciji je gornja polovina prozora bila zamračena kako bi sprečili prikupljanje svetlosti iz ostalih oblasti pražnjenja.
- Bočno u nivou napajane elektrode (pozicija 3). S obzirom na cilindričnu geometriju reaktora, na ovaj način je prikupljena svetlost iz celog prostora pražnjenja, od napajane do uzemljene elektrode, odnosno zida komore.

Treba imati u vidu da je period pražnjenja 74 ns a da je vreme prikupljanja signala na čipu 300 ms. Takođe upotrebljenim sočivom je prikupljana emisija zračenja iz prostora koji se nalazi direktno ispred njega, pa možemo da kažemo da su sva snimanja bila vremenski i prostorno integrisana duž vidnog polja. Šematski prikaz se na slici 2.1.18. S obzirom na to da tokom snimanja spektara nije potrebno da se sačuva 2D informacija o slici, poželjno je da se koristi FVB režim (*eng* Full Vertical Binding). Tada će se vrednosti svih piksela iz jedna kolone sabrati u jednu vrednost. Kao izlaz se dobija grafik kome će se na X-osi nalaziti broj piksela dok će na Y-osi biti osvetljenje, odnosno intenzitet pika.

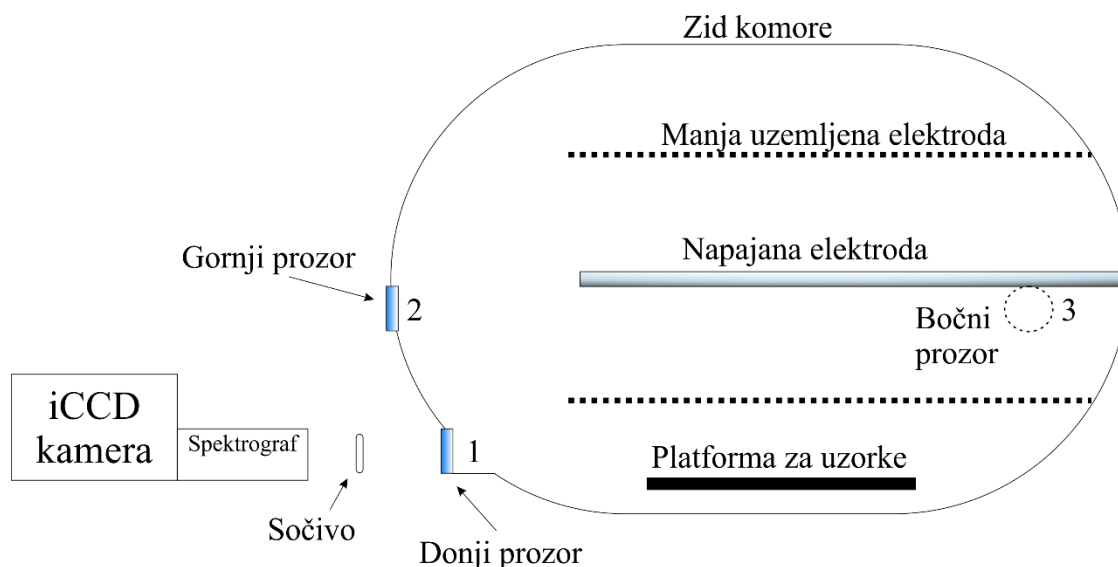

Slika 2.1.18 Šematski prikaz eksperimentalne postavke za spektrometrijska snimanja. Snimanja su obavljena na tri pozicije: 1 – prozor u nivou sa platformom za uzorke (frontalno), 2 – prozor u nivou napajane elektrode (frontalno) i 3 – bočni prozor u nivou napajane elektrode

Metoda optičke aktinometrije je iskorišćena za računanje apsolutnih koncentracija atomskog kiseonika i stepena disocijacije molekulskog kiseonika. Kao aktinometar je korišćen argon koji je dodat kiseoniku (99% O₂+1% Ar). Za proračune su korišćene linije kiseonikovog atoma na 844 nm i argona na 810 nm. Njihove intenzitete možemo da definišemo kao:

$$I_O = C(\lambda_H) \frac{hc}{\lambda_O} A_{ji}^O N_{O_j} \quad (2.2)$$

$$I_{Ar} = C(\lambda_{Ar}) \frac{hc}{\lambda_{Ar}} A_{pq}^{Ar} N_{Ar_p} \quad (2.3)$$

Ovde je sa $C(\lambda_x)$ obeležena efikasnost spektroskopskog sistema na talasnoj dužini λ_x dok su sa h i c označene Plankova konstanta i brzina svetlosti. Ajnštajnov koeficijent za spontanu emisiju kiseonikovog atoma tokom deeksticacije sa nivoa j na nivo i je označen kao A_{ji}^O a isti princip je upotrebljen za argon oznakom A_{pq}^{Ar} . N_{O_j} i N_{Ar_p} su koncentracije pobuđenih atoma.

Pobuđeno stanje atomskog kiseonika može da nastane u sudaru elektrona i atoma u osnovnom stanju ili disocijativnom ekscitacijom molekula O₂. Populisanje O_j nivoa kroz deeksticaciju viših pobuđenih stanja će biti uzeto u obzir samo preko koeficijenata za brzine reakcija. Do de-populisanja dolazi spontanom emisijom fotona ili sudarnim gašenjem O₂ molekulom (*eng* quenching). Pobuđeno stanje emitujućeg argona može da nastane samo u sudaru sa elektronom. De-populisanje pobuđenog argona se, takođe, odvija procesom spontane emisije fotona ili tokom sudara sa molekulom kiseonika. Imajući ovo u vidu, možemo da napišemo formule za promenu koncentracije emitera:

$$\frac{dN_{O_j}}{dt} = N_e N_O k_O^{dir} + N_e N_{O_2} k_O^{dis} - N_{O_j} A_{ji}^O - N_{O_j} q_{O_j} \quad (2.4)$$

$$\frac{dN_{Ar_p}}{dt} = N_e N_{Ar} k_{Ar}^{dir} - N_{Ar_p} A_{pq}^{Ar} - N_{Ar_p} q_{Ar_p} \quad (2.5)$$

U ovim formulama N_x predstavlja koncentraciju vrste x , a N_e je koncentracija elektrona. Brzine gašenja pobuđenih vrsta su obeležene sa q_{O_j} i q_{Ar_p} dok su k_x^{dir} i k_x^{dis} brzine reakcija za direktnu i disocijativnu ekscitaciju. Kombinovanjem ovih formula može da se dobije jednačina u kojoj odnos nepoznate koncentracije atoma kiseonika i poznate koncentracije argona zavisi direktno od konstanti i odnosa intenziteta linija:

Asimetrično kapacitivno spregnuto pražnjenje velike zapremine

$$\frac{N_O}{N_{Ar}} = \frac{I_O}{I_{Ar}} \gamma \frac{k_{Ar}^{dir}}{k_O^{dir}(1+Ds)} \quad (2.6)$$

Ovde je

$$\gamma = \frac{C(\lambda_{Ar})\lambda_O A_{Arp}(\sum_j A_{Oj})}{C(\lambda_O)\lambda_{Ar} A_{Oj}(\sum_p A_{Arpq})} \quad (2.7)$$

i

$$Ds = N_{O_2} k_O^{dis} / (N_O k_O^{dir}). \quad (2.8)$$

Ds predstavlja odnos disocijativne prema direktnoj ekscitaciji a faktorom (Ds+1) se uzima u obzir doprinos disocijacije elektronskim sudarom.

Stepen disocijacije molekula kiseonika se dobija iz formule:

$$x = \frac{1}{2} \cdot \frac{N_O}{N_{O_2}^0} = \frac{N_O/2}{N_{O_2} + N_O/2}. \quad (2.9)$$

Odnosno, imajući u vidu prethodno napisano, možemo ga dobiti iz:

$$x = \left(\frac{N_{Ar}}{N_{O_2}^0} \frac{I_O}{I_{Ar}} \gamma \frac{k_{Ar}^{dir}}{k_O^{dir}} - \frac{k_O^{dis}}{k_O^{dir}} \right) / \left(2 - \frac{k_O^{dis}}{k_O^{dir}} \right). \quad (2.10)$$

Koeficijente za brzinu reakcija smo računali iz setova preseka koje smo preuzeli iz literature [134]–[136] uz pretpostavku Maksvelove raspodele energija elektrona. Dobile brzinu reakcija u zavisnosti od T_e , za pobudne procese, su prikazane na slici 2.1.19. Konkretni vrednosti koeficijenata koje su korišćene su uzete za energiju elektrona od 3 eV i predstavljene su u tabeli 2.1.1 sa naznačenom literaturom odakle su preuzete ili računane.

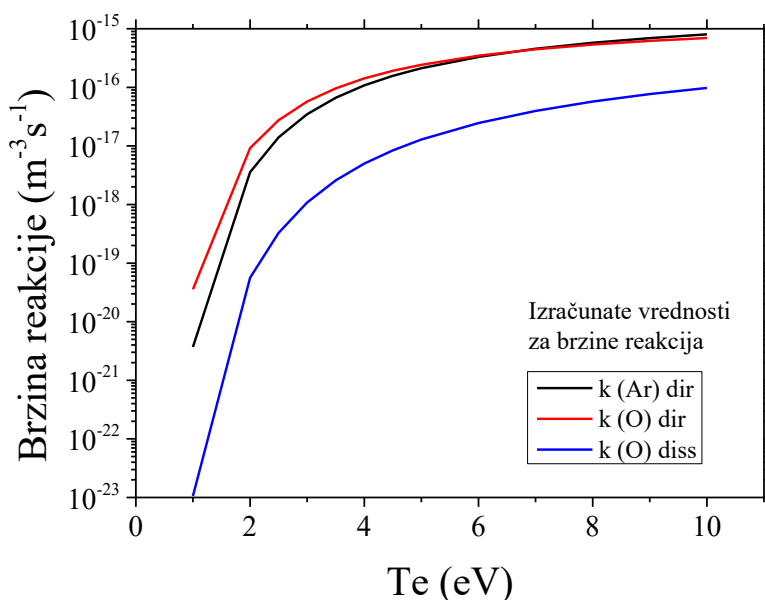

Slika 2.1.19 Izračunate brzine reakcija za direktno i disocijativno pobuđivanje kiseonikovog atoma i direktno pobuđivanje argona u sudarima sa elektronima

Asimetrično kapacitivno spregnuto pražnjenje velike zapremine

Tabela 2.1.1 Vrednosti koeficijenta potrebnih za spektroskopske proračune

	Vrednost	izvor
A_{ji}^O	$32.2 \cdot 10^6 \text{s}^{-1}$	[NIST]
A_{pq}^{Ar}	$33.1 \cdot 10^6 \text{s}^{-1}$	[NIST]
k_O^{dir}	$5.72162 \cdot 10^{-17} \text{m}^3 \text{s}^{-1}$	[134]
k_O^{dis}	$1.08564 \cdot 10^{-18} \text{m}^3 \text{s}^{-1}$	[135]
k_{Ar}^{dir}	$3.48079 \cdot 10^{-17} \text{m}^3 \text{s}^{-1}$	[136]
q_{O_j}	$8 \cdot 10^{-16} \text{m}^3 \text{s}^{-1}$	
q_{Ar_p}	$8 \cdot 10^{-16} \text{m}^3 \text{s}^{-1}$	

S obzirom na to da se pozicija difrakcione rešetke u korišćenom spektrometru podešava ručno, pre početka merenja je potrebno uraditi kalibraciju sistema po talasnim dužinama. Za tu svrhu je korišćena živa-argonska lampa (Newport Spectral Calibration Lamp Hg(Ar) 18±5 mA). U uputstvu proizvođača nalazi se precizan spisak talasnih dužina koje se pojavljuju u njenom emisionom spektru. Snimanjem zračenja lampe se dobija spektar kao intenzitet u zavisnosti od rednog broja piksela ICCD kamere. Poređenjem uputstva i dobijenog spektra može da se ustanovi na kom se pikselu nalazi emisiona linija lampe, odnosno koji piksel odgovara toj specifičnoj talasnoj dužini. Dodatno, poznajući razliku talasnih dužina dve referentne linije koje su naznačene u uputstvu moguće je odrediti rezoluciju spektra odnosno razliku talasnih dužina između dva susedna piksela.

2.2 REZULTATI MERENJA I DISKUSIJA

2.2.1 STRUJNO-NAPONSKE KARAKTERISTIKE ASIMETRIČNOG KAPACITIVNO SPREGNUTOG PRAŽNJENJA

2.2.1.1 Uzemljena elektroda većeg poluprečnika

Pre diskusije o električnim osobinama ovog sistema treba se još jednom osvrnuti na sam proces merenja. Hargis *et al.* [17], uvode dodatni shunt koji se sastoji od promenljivog kondenzatora i zavojnice kako bi eliminisali struju pomeraja I_d (*eng.* displacement current) u kolu. Ova struja je proporcionalna promeni fluksa električnog polja i javlja se zbog toga što sama komora predstavlja kondenzator. S obzirom na to da je ovaj plazma reaktor zapravo cilindrični kondenzator, struju pomeraja je tokom obrade podataka neophodno oduzeti od ukupne struje. Međutim, da bi to bilo moguće potrebno je da se zna kapacitivnost tog kondenzatora, odnosno reaktora u našem slučaju. Kako bi odredili ovu veličinu, u komoru se upušta vazduh sve do atmosferskog pritiska. U ovim uslovima nije moguće ostvariti električni proboj, pa će ukupna struja kroz sistem zapravo biti jednaka samo struji pomeraja. Dalje je potrebno derivativnim sondama izmeriti vrednosti struje i napona na napajanoj elektrodi. Iz dobijenih veličina je moguće izračunati ukupnu impedansu sistema, za koju se sada može pretpostaviti da je samo kapacitivne prirode, odnosno da je $z = 1/\omega C$ i u našem slučaju ona iznosi $746,53 \Omega$. Znajući da je $\omega = 2\pi\nu$ i da je $\nu = 13,56 \text{ MHz}$ dobija se kapacitivnost od $15,7 \text{ pF}$. Ova vrednost kapacitivnosti sistema je korišćena kako bi se struja pomeraja oduzela numerički prilikom obrade podataka [137].

Jedan primer obrade strujnog signala je prikazan na slici 2.2.1. Naponski signal koji je snimljen neposrednim merenjima na samoj strujnoj sondi, je na slici prikazan crnom bojom i ima amplitudu $\sim 1 \text{ V}$. Crvenom bojom je predstavljen signal koji smo nazvali kalibrisan a on se dobija nakon množenja signala koji su dobijeni direktno sa osciloskopa vrednostima sa kalibracionih krivi. Konačni oblik strujnog signala se dobija oduzimanjem struje pomeraja i on je predstavljen plavom bojom. U primeru sa slike, struja pomeraja iznosi oko 9% ukupne struje.

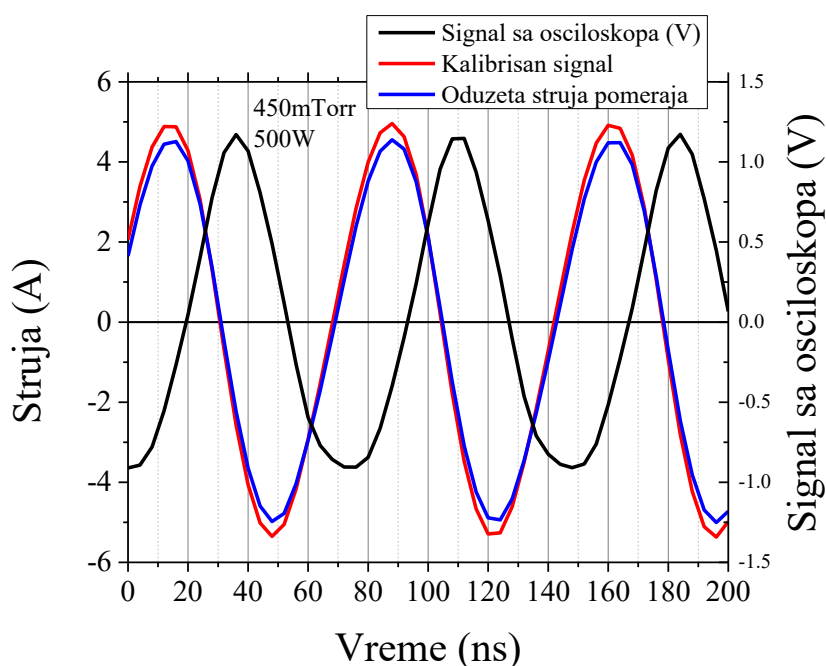

Slika 2.2.1 Primer obrade strujnog signala. Crna linija – podaci dobijeni sa osciloskopa, Crvena linija – fazno i amplitudno kalibrisan signal, Plava linija – vrednost nakon oduzimanja struje pomeraja.

Primer obrade naponskog signala je prikazan na slici 2.2.2. Podaci dobijeni sa osciloskopa, odnosno nekalibrisan signal, je predstavljen crnom bojom i ima amplitudu od oko 0,6 V. Nakon množenja kalibracionim krivama se dobija signal koji je fazno pomeren i ima amplitudu koja je nešto viša od 350 V.

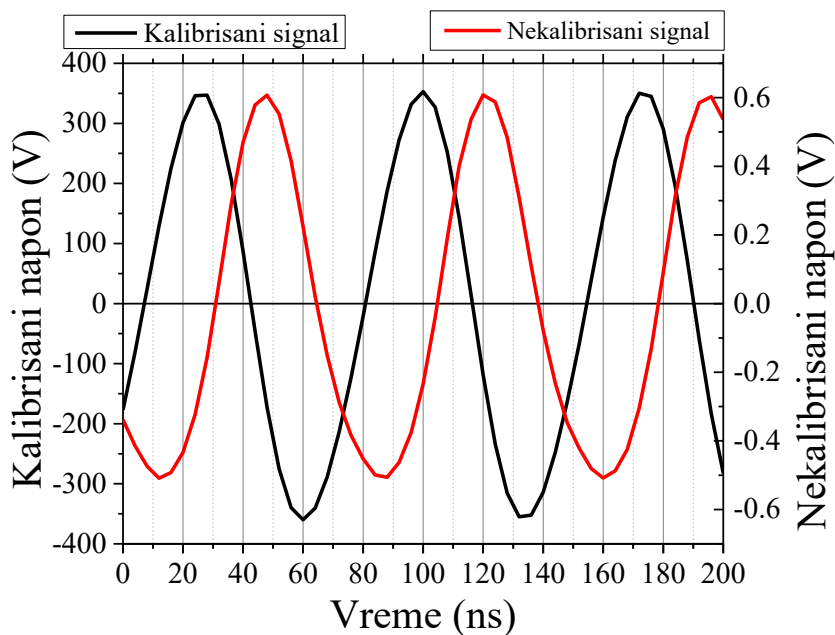

Slika 2.2.2 Primer obrade naponskog signala. Nekalibrisan signal – podaci dobijeni direktno sa osciloskopa, kalibrisan signal – podaci nakon množenja kalibracionim krivama

Nešto bolji uvid u prirodu signala može da se dobije ako se pogleda kako oni izgledaju u frekventnom domenu. Da bi signale preveli iz vremenskog u frekventni domen, primenjuje se Furijeova transformacija upotrebom FFT (*eng* fast fourier transform) algoritma.

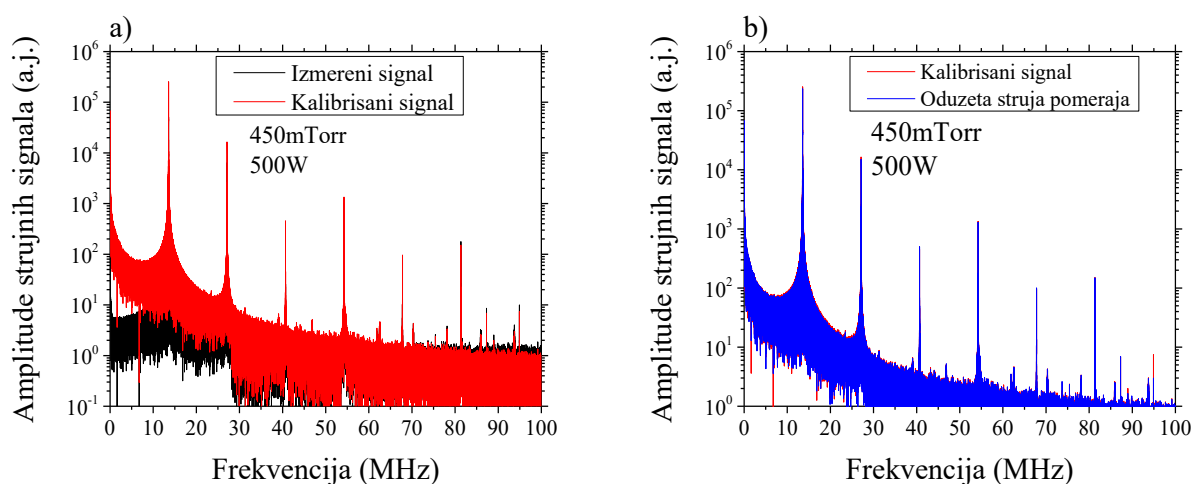

Slika 2.2.3 Amplitude strujnih signala u zavisnosti od frekvencije: a) signal dobijen direktno sa osciloskopa i posle množenja kalibracionim krivama i b) nakon oduzimanja struje pomeraja

Primer frekventnog sastava strujnog signala, odnosno amplituda signala u zavisnosti od frekvencije, koji je snimljen na pritisku od 450 mTorr i sa primenjenom snagom od 500 W je prikazan na slici 2.2.3. Na slici 2.2.3 a) se vidi odnos signala koji je snimljen direktno sa osciloskopa i predstavljen je crnom bojom i signala koji je pomnožen kalibracionim krivama a predstavljen je crvenom bojom. U oba slučaja je najdominantniji osnovni harmonik na 13,56 MHz. Drugi harmonik je za jedan red veličine manje intenzivan, dok su amplitude signala na višim harmonicima za dva do tri reda veličine niže u odnosu na osnovni harmonik. Na slici 2.2.3 b) je prikazan odnos amplituda strujnih signala nakon množenja kalibracionim krivama i nakon oduzimanja struje pomeraja. S obzirom na to da je u konkretnom primeru struja pomeraja mala u odnosu na ukupnu struju, njenim oduzimanjem se frekventni sastav signala ne menja značajno.

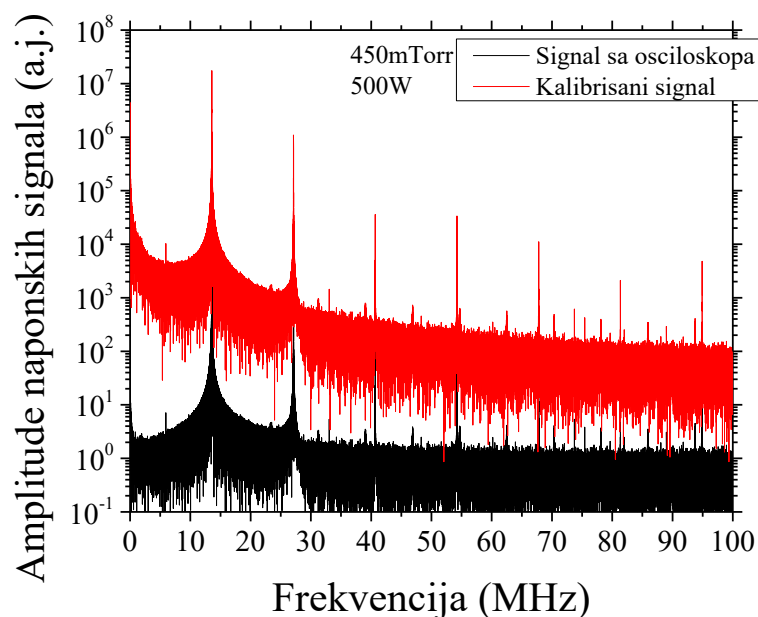

Slika 2.2.4 Amplitude naponskih signala u zavisnosti od frekvencije, tokom merenja i nakon kalibracije

Primeri amplituda naponskih signala u zavisnosti od frekvencije koji su snimljeni pri istim uslovima (450 mTorr i 500 W) su prikazani na slici 2.2.4. Kalibrisani signal je zbog množenja kalibracionim krivama sa slike 2.1.7 b) veći od nekalibrisanog za 3 do 4 reda veličine. Najdominantniji su osnovni i drugi harmonik dok su viši harmonici 100 do 1000 puta manji od osnovnog.

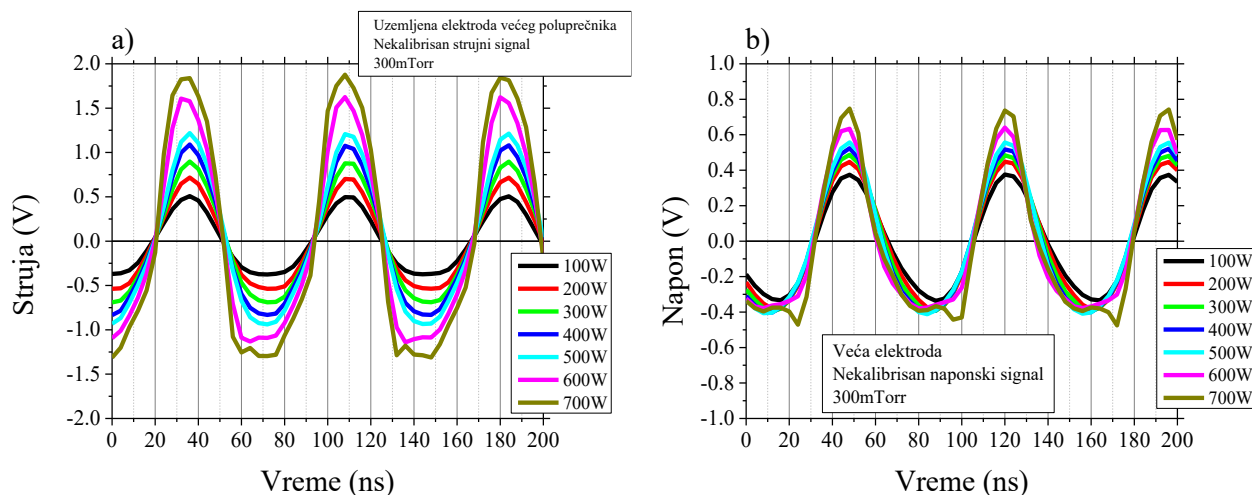

Slika 2.2.5 Strujni i naponski signali dobijeni direktno sa a) strujne i b) naponske sonde na fiksnom pritisku i različitim snagama

Nešto drugačiji uvid u električne osobine sistema može da se dobije ako se pogleda kako će promena snage da utiče na intenzitet i oblik strujnih i naponskih signala. Na slici 2.2.5 su prikazana merenja na fiksnom pritisku od 300 mTorr, dok je primenjena snaga menjana u opsegu od 100 do 700 W. U pitanju su nekalibrisane krive odnosno naponi snimljeni direktno sa osciloskopa. Signali

Asimetrično kapacitivno spregnuto pražnjenje velike zapremine

dobijeni sa strujne sonde su prikazani na slici 2.2.5 a) a sa naponske na slici 2.2.5 b). S obzirom da su u pitanju neobrađeni podaci, struja je predstavljena u voltima. Kao što je i očekivano, povećanje snage će da dovede do povećanja amplitude i ono je uočljivije za strujne signale. Takođe je primetno da sa porastom snage oblik signala sve više odstupa od pravilne sinusoide, dok je na najvišim snagama primetan i značajan doprinos viših harmonika.

Nakon procesa fazne i amplitudne kalibracije ove krive izgledaju mnogo „pravilnije“ i prikazane su na slici 2.2.6. Može da se primeti da će povećanje snage sa 100 na 700 W dovesti do dupliranja naponskog signala dok se struja za to vreme učtverostruči. Razlog za ovo je jačina sprege svake od sonda u odnosu na napajani vod.

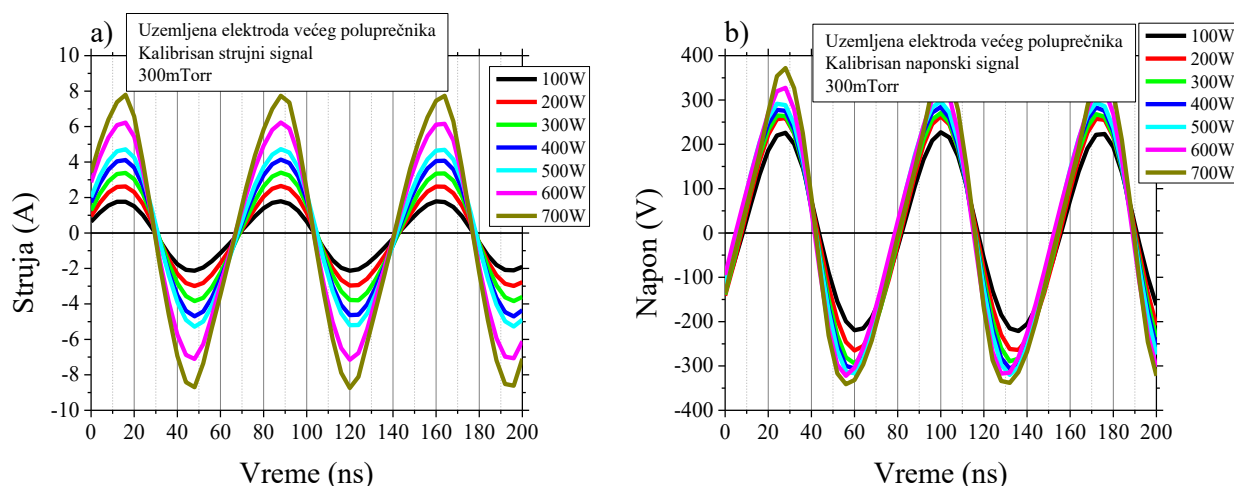

Slika 2.2.6 Oblik signala a) struje i b) napona nakon amplitudne i fazne kalibracije na fiksnom pritisku i različitim snagama.

Detaljniji uvid u efekte primenjene snage na električne osobine sistema može da se dobije ako se pogleda kako ona utiče na frekventni sastav. Na slici 2.2.7 je prikazano kako se prvih 6 harmonika signala koji su dobijeni direktno sa osciloskopa ponašaju sa promenom snage. Izmereni su na fiksnom pritisku od 300 mTorr. Na slici 2.2.7 a) je prikazan efekat snage na frekventni sastav strujnog signala. Primetno je da intenzitet amplituda svih harmonika, uključujući i osnovni, raste sa povećanjem snage što je i očekivano ali se vidi da je ovaj porast znatno izraženiji na višim harmonicima. Ilustracije radi napomenućemo da je intenzitet osnovnog harmonika povećan nešto manje od 4 puta. Sa druge strane, 6.-ti harmonik je na 700 W preko 25 puta intenzivniji nego na 100 W. Nešto je drugačija situacija kada se posmatra frekventni sastav naponskog signala, slika 2.2.7 b). U celom opsegu primenjenih snaga, intenzitet osnovnog harmonika se povećao oko 50 % dok su neki od viših harmonika porasli i više desetina puta. Upravo se ovo povećanje intenziteta viših harmonika na slici 2.2.5 manifestuje kroz pojavu „zubaca“ na vremenskim signalima koji su snimljeni na najvišim snagama.

Asimetrično kapacitivno spregnuto pražnjenje velike zapremine

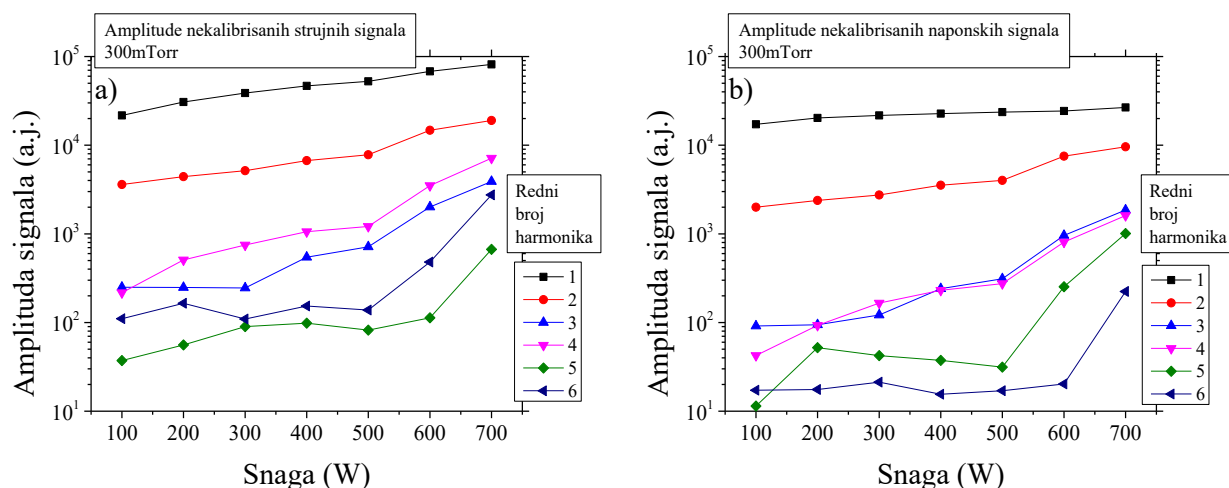

Slika 2.2.7 Amplitude prvih 6 harmonika signala koji su dobijeni direktno sa a) strujne i b) naponske sonde, 300 mTorr.

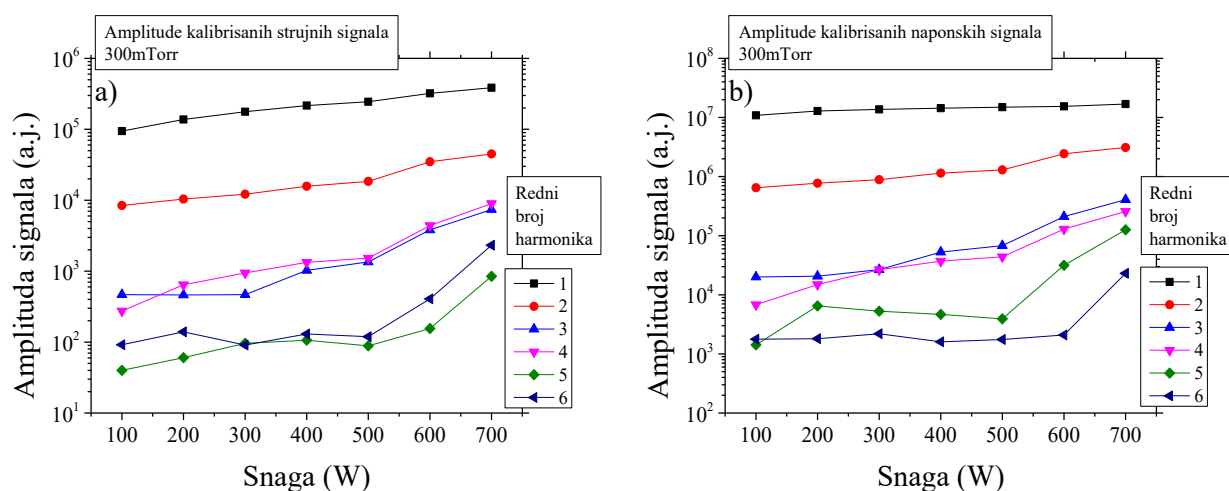

Slika 2.2.8 Amplitude prvih 6 harmonika a) strujnog i b) naponskog signala nakon množenja kalibracionim krivama, 300 mTorr.

Efekat primenjene snage na frekventni sastav signala koji su dobijeni nakon množenja kalibracionim krivama je prikazan na slici 2.2.8. U pitanju su ista merenja u istim uslovima, na pritisku od 300 mTorr sa primenjenim snagama između 100 i 700 W. Zbog toga što kalibracione krive imaju eksponencijalno opadajuću zavisnost od frekvencije (slika 2.1.7) odnos amplituda osnovnog i viših harmonika će biti znatno veći nego pre kalibracije. Time je efektivno povećan doprinos osnovnog harmonika što se u vremenskom domenu manifestuje kroz oblik signala koji je znatno bliži pravilnoj sinusoidi (slika 2.2.6).

Asimetrično kapacitivno spregnuto pražnjenje velike zapremine

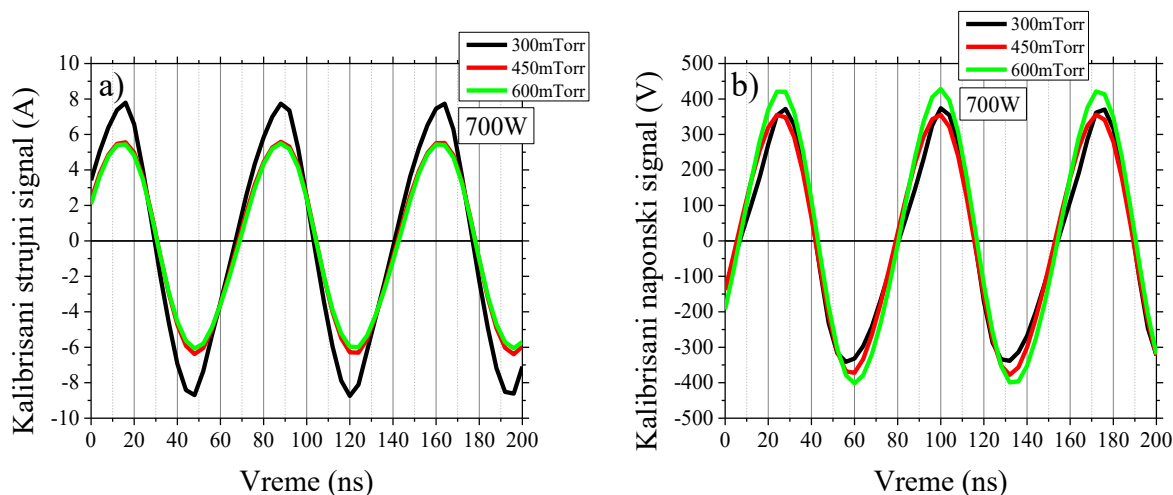

Slika 2.2.9 Promena kalibriranih signala (a) struje i (b) napona u zavisnosti od pritiska, snaga data RF izvorom je 700 W

Pored uticaja promene snage na električne osobine sistema, potrebno je proveriti i kako na njih utiče promena pritiska. Na slici 2.2.9 su prikazani kalibrirani strujni (2.2.9 a) i naponski (2.2.9 b) signali u vremenskom domenu. Snimljeni su na fiksnoj snazi od 700 W i na tri različita pritiska. Zanimljivo je da će promena ovog parametra imati potpuno suprotan efekat na struju i napon. Dok je najintenzivniji strujni signal dobijen na 300 mTorr i opadao je sa porastom pritiska, najveći napon je, obrnuto, izmeren na 600 mTorr.

Promenu električnih osobina u zavisnosti od promene pritiska je takođe korisno posmatrati i kroz frekventni domen. Biće prikazana samo prva dva harmonika, jer je već ustanovljeno da su treći i ostali viši harmonici, kod kalibriranih signala, za minimum dva reda veličine manji od osnovnog. Rezultati su prikazani na slici 2.2.10. Prvi harmonik je označen kvadratima dok je drugi harmonik obeležen krugovima. Amplitude strujnih signala su gotovo identične sve do snage od 600 W, kada amplitude na pritisku od 300 mTorr počinju da rastu znatno brže nego na druga dva pritiska. Ovaj porast je primetan na oba harmonika. Sa druge strane, osnovni harmonik naponskog signala će da raste kako sa povećanjem pritiska tako i sa povećanjem snage. Zanimljivo je da, poput strujnog, i naponski signal na 300 mTorr ima veliki skok na drugom harmoniku na snagama od 600 i 700 W.

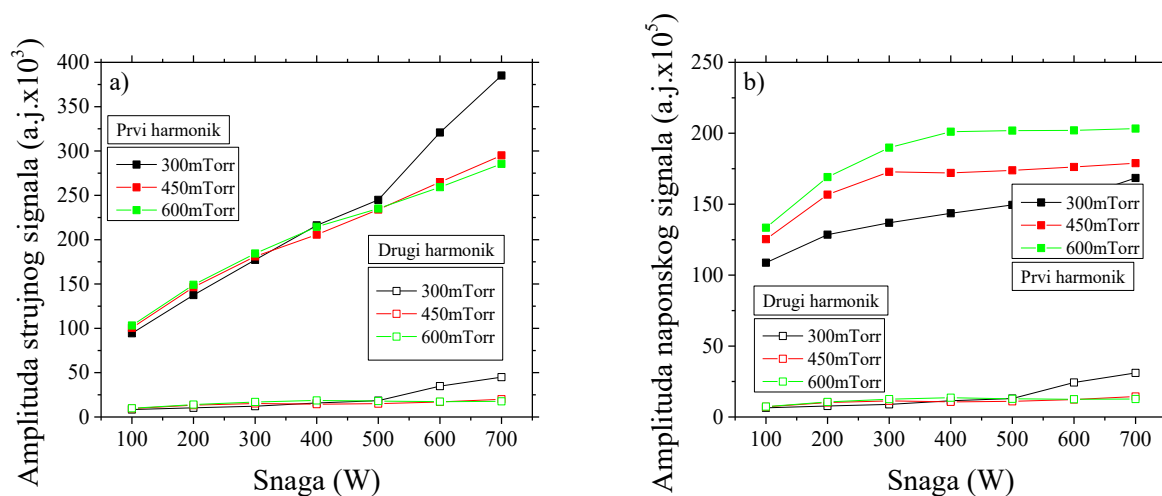

Slika 2.2.10 Zavisnost intenziteta prvog i drugog harmonika kalibriranog signala (a) struje i (b) napona od nominalne snage i pritiska

Ne može se govoriti o električnim karakteristikama sistema bez osvrta na $I_{\text{rms}}-V_{\text{rms}}$ osobine pražnjenja. One su predstavljene na slici 2.2.11. Svaka tačka na grafiku predstavlja jedan par $I_{\text{rms}}-V_{\text{rms}}$ vrednosti koje su dobijene na snagama od 100 W do 700 W sa korakom od 100 W. Vidimo da su najmanje RMS vrednosti napona izmerene na pritisku od 300 mTorr ali da su i najveće vrednosti struje dobijene upravo na tom pritisku. Zavisnost napona od struje je u ovom reaktoru, u drugom radnom gasu (vazduhu), već merena na malim pritiscima [45] i iz oblika te zavisnosti je zaključeno da se pražnjenje nalazi u α režimu. Iako su struje, izmerene u merenjima za potrebe ove disertacije, veće a naponi manji, jasno je da se pražnjenje nalazi u istom režimu i da, na pritisku od 300 mTorr, u njemu ostaje u celom opsegu primenjenih snaga. Međutim, povećavanjem snage na pritiscima od 450 mTorr i 600 mTorr se dolazi do određene tačke nakon koje ne dolazi do značajne promene u naponu ali će dalje povećanje snage pražnjenja dovesti do porasta struje. Nakon te tačke, plazma se nalazi u γ režimu. S obzirom na to da se u našem sistemu plazma napaja izvorom snage, a ne izvorom struje ili napona, i sam izvor se prilagođava plazmi tako što isporučuje najoptimalnije vrednosti struje i napona koje su neophodne za održavanje pražnjenja. Sa druge strane i plazma se prilagođava uslovima u komori i zavisno od pritiska, osobina prielektrodnih oblasti i snage će od izvora „zahtevati“ onu kombinaciju parametara u kojoj će pražnjenje biti najstabilnije. Kako bi ovo bilo jasnije, obratimo pažnju na vrednosti impedanse same plazme. S obzirom na to da su $I_{\text{rms}}-V_{\text{rms}}$ osobine linearne u oba režima, impedansu smo računali linearnim fitom kao koeficijent zavisnosti $V_{\text{rms}}(I_{\text{rms}})$. U α režimu će na pritisku od 300 mTorr ona iznositi $18,6 \Omega \pm 2,1 \Omega$. Povećanjem pritiska će rasti i impedansa, pa će na 450 mTorr ona biti $59,4 \Omega \pm 6,4 \Omega$, dok je na 600 mTorr ona samo neznatno veća i iznosi $61,6 \Omega \pm 6 \Omega$. Međutim, kada plazma pređe u γ režim dolazi do velikog pada impedanse tako da na 450 mTorr ona iznosi $7,1 \Omega \pm 0,4 \Omega$ a na 600 mTorr svega $3,8 \Omega$. Jasno je da će u uslovima ovako malih impedansi sistemu biti znatno „lakše“, odnosno efikasnije da snagu povećava podizanjem struje umesto napona. Upravo zbog toga će podizanjem snage nakon prelaska iz α u γ režim, što se na 450 mTorr događa na 400 W a na 600 mTorr na 300 W, napon ostati praktično konstantan, dok će rms vrednosti struje biti značajno veće.

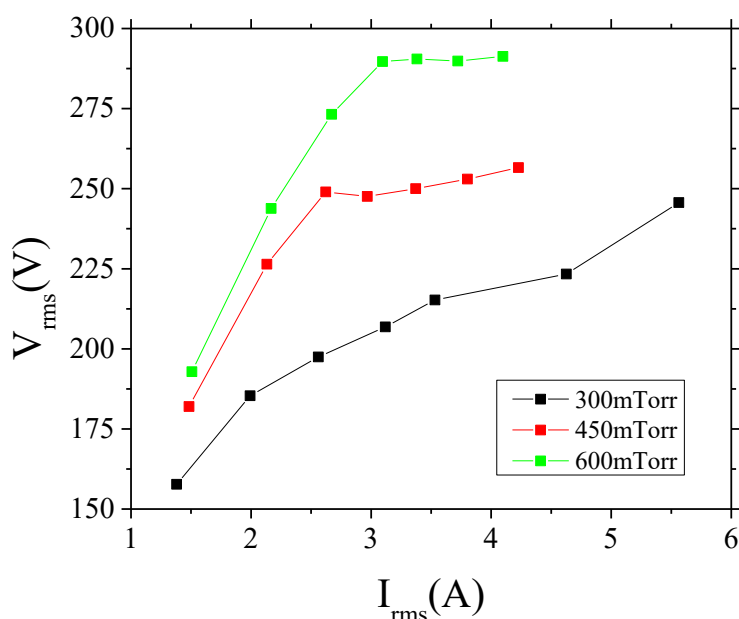

Slika 2.2.11 $I_{\text{rms}}-V_{\text{rms}}$ karakteristika sistema sa uzemljenom elektrodom većeg poluprečnika. Svaka tačka predstavlja jedan par $I_{\text{rms}}-V_{\text{rms}}$ vrednosti dobijenih na istoj snazi.

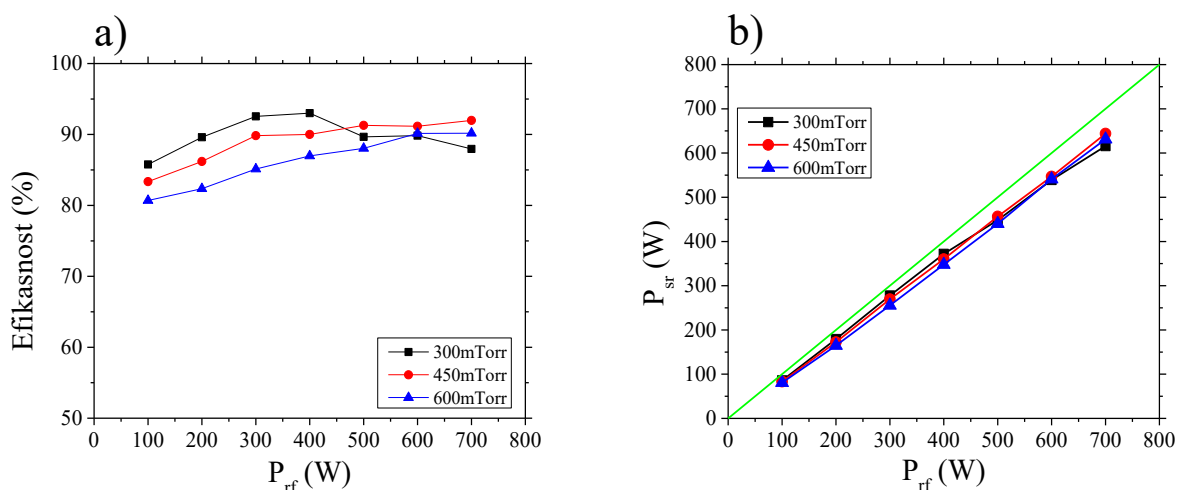

Slika 2.2.12 Efikasnost sistema predstavljena kao (a) procenat nominalne snage i (b) srednja vrednost izmerene snage na napajanoj elektrodi u zavisnosti od nominalne snage generatora.

Jedna od najvažnijih osobina sistema, pogotovo za moguće industrijske primene, je efikasnost predavanja snage plazmi. Ovu veličinu je moguće predstaviti kao efikasnost u zavisnosti od nominalne snage što je prikazano na slici 2.2.12 a) ili kao izmerenu snagu, koju smo označili kao P_{sr} , u zavisnosti od snage poslate sa RF generatora, P_{rf} , što je prikazano na slici 2.2.12 b). Efikasnost sistema će, na svim pritiscima, sve do snage od 400 W, praktično linearno da raste sa nominalnom snagom generatora, pa je njen maksimum dobijen upravo na toj snazi i na pritisku od 300 mTorr i iznosi 93 %. Ukoliko ostanemo na istom pritisku, dalje povećanje snage će da dovede do primetnog pada u odnosu izmerene i nominalne snage. Jedan od mogućih razloga za ovakvo ponašanje efikasnosti, ali i ostalih električnih osobina, je efektivna promena simetrije sistema. Naime, kada je u komori pritisak veliki ili je primenjena snaga mala, plazma ne zauzima celu zapreminu komore već je skoncentrisana u prostoru oko napajane elektrode. Povećanje snage će dovesti do povećanja napona odnosno do povećanja električnog polja, čiji će se efekti osećati na rastojanjima koja su sve dalje od napajane elektrode. Ovo će biti vidljivo kao povećanje zapremine koju plazma zauzima. U uslovima najmanjeg pritiska i najvećih primenjenih snaga uzemljeni zid komore postaje „vidljiv“ za pražnjenje. To znači da će prielektrodna oblast tek na tim uslovima da se formira na samoj uzemljenoj elektrodi. Kada se to desi, dolazi do porasta struje u pražnjenju ali i do promene u efikasnosti predaje snage sa generatora na plazmu. Na manjim pritiscima i snagama ulogu uzemljene elektrode preuzima neutralni gas koji okružuje plazmu a prielektrodna oblast se umesto na uzemljenoj elektrodi formira u oblasti između plazme i neutralnog gasa.

2.2.1.2 UZEMLJENA ELEKTRODA MANJEG POLUPREČNIKA

Smanjivanje efektivne zapremine komore za pražnjenje, odnosno postavljanje dodatne uzemljene elektrode, manjeg poluprečnika, bi trebalo da značajno utiče na električne karakteristike sistema pre svega zbog promene kapacitivnosti. Da bi se odredila nova kapacitivnost sistema, primenjuje se isti postupak kao i pre postavljanja dodatne uzemljene elektrode. Prvo se upušta vazduh do atmosferskog pritiska kako bi se iz izmerene struje i napona dobila ukupna impedansa kola za koju pretpostavljamo da je samo kapacitivne prirode. U ovom slučaju je dobijeno da impedansa iznosi 229 Ω , odnosno da je kapacitivnost sistema 50 pF.

Asimetrično kapacitivno spregnuto pražnjenje velike zapremine

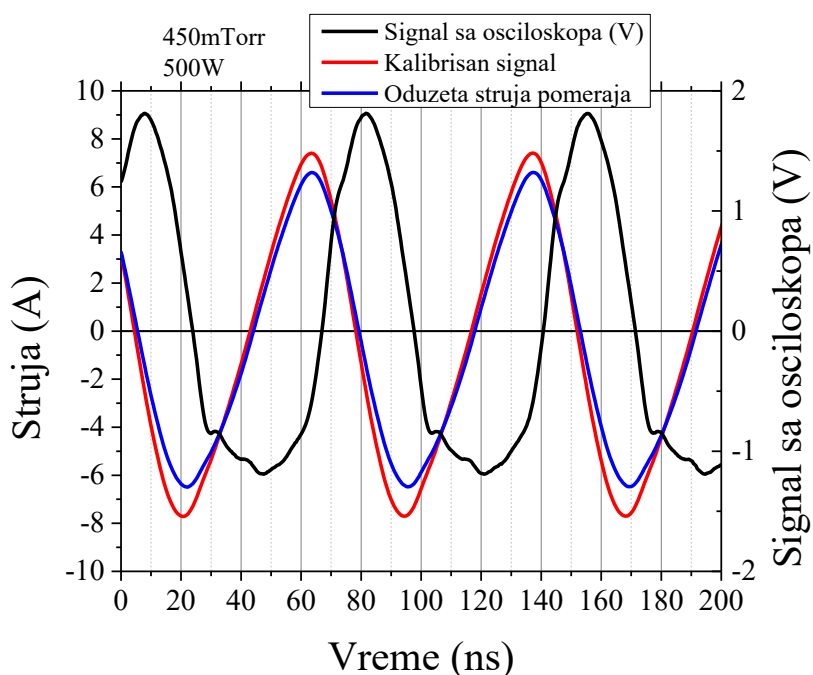

Slika 2.2.13 Primer strujnog signala u komori sa uzemljenom elektrodom manjeg poluprečnika. Crna linija – signal sa osciloskopa, crvena linija – signal nakon množenja kalibracionim krivama, plava linija – oduzeta struja pomeraja.

Jedan primer postupka obrade strujnog signala kada je u sistemu postavljena uzemljena elektroda manjeg poluprečnika je prikazan na slici 2.2.13. Podaci su snimljeni na pritisku od 450 mTorr i nominalnoj snazi od 500 W. Primetno je da signal koji je dobijen direktno sa osciloskopa već na ovim uslovima odstupa od pravilne sinusoide. Takođe, zbog značajno veće kapacitivnosti struja pomeraja ima nešto veći doprinos u ukupnom signalu i na ovim uslovima je on oko 18 %.

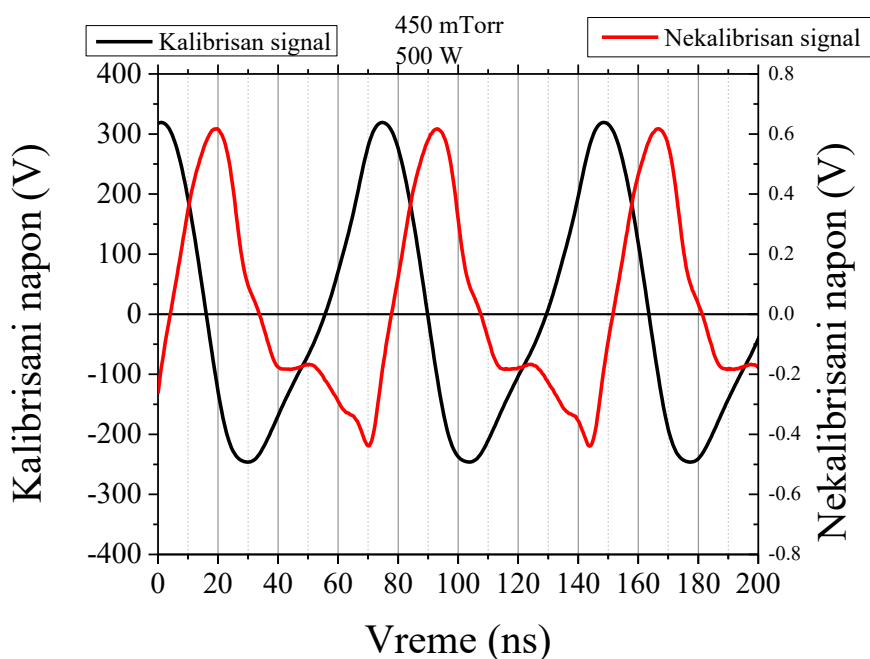

Slika 2.2.14 Primer naponskog signala u komori sa uzemljenom elektrodom manjeg poluprečnika. Nekalibrisan signal – podaci dobijeni direktno sa osciloskopa, kalibrisan signal – podaci nakon množenja kalibracionim krivama.

Na slici 2.2.14 nalaze se signali dobijeni naponskom sondom. Snimljeni su u istim uslovima kao i signali sa slike 2.2.13. Crvenom linijom je označen signal sa osciloskopa, dok je crnom linijom označen signal koji se dobija nakon fazne i amplitudne kalibracije. Vidimo da podaci koji su dobijeni direktno sa osciloskopa takođe odstupaju od pravilne sinusoidne, najverovatnije zbog doprinosa viših harmonika.

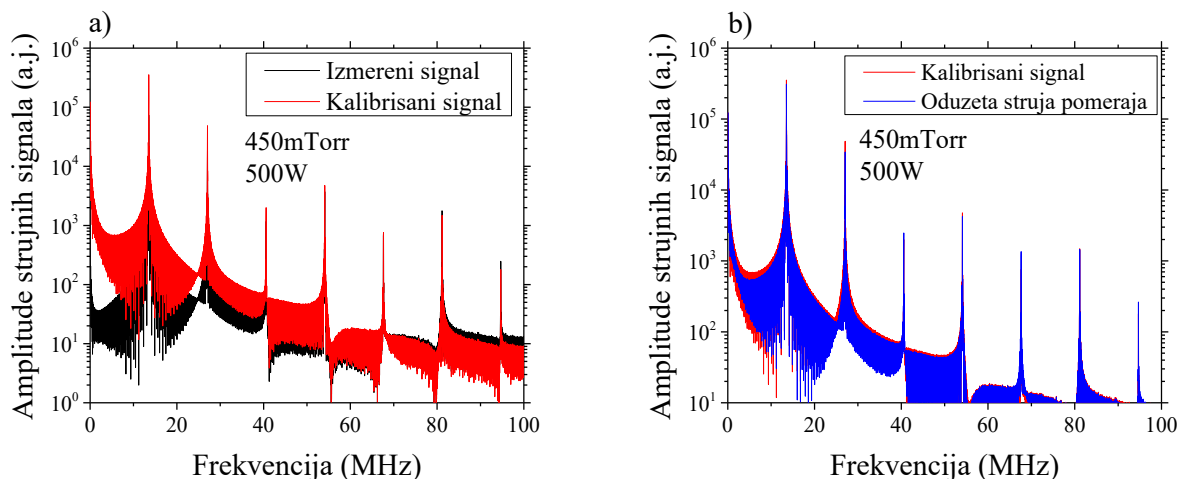

Slika 2.2.15 Amplitude strujnih signala a) izmerenih direktno sa osciloskopa i b) nakon oduzimanja struje pomeraja u zavisnosti od frekvencije.

Primer frekventnog sastava strujnog signala, kada je u komori postavljena uzemljena elektroda manjeg poluprečnika, je prikazan na slici 2.2.15. Na slici 2.2.15 a) se nalaze amplitude signala koji snimljen direktno sa osciloskopa i signala koji je fazno i amplitudno kalibrisan. Zbog oblika kalibracionih krivi (slika 2.1.7 a)), amplituda kalibrisanog signala na osnovnoj frekvenciji je za nekoliko redova veličine veća u odnosu na nekalibrisan signal, dok su im na višim harmonicima vrednosti približno jednake. Na slici 2.2.15 b) je prikazana razlika između signala koji je fazno i amplitudno kalibrisan i signala kome je oduzeta struja pomeraja. Na frekvenciji od 13,56 MHz, ova razlika iznosi oko 13 %. Treba primetiti da intenzitet amplitude na trećem i četvrtom harmoniku iznosi oko 1 % intenziteta osnovnog harmonika.

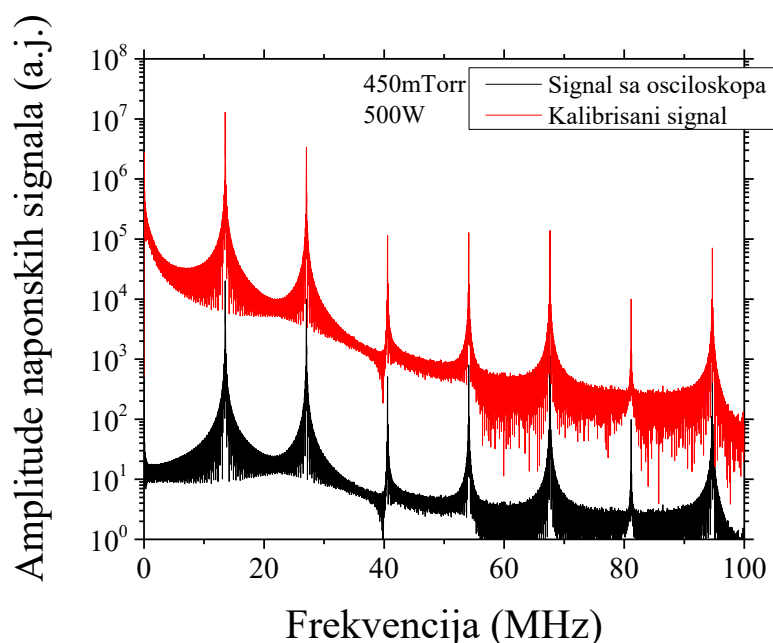

Slika 2.2.16 Amplitude naponskih signala. Signal dobijen direktno sa osciloskopa – crna boja, signal nakon fazne i amplitudne kalibracije – crvena boja.

Amplitude naponskog signala pre i posle kalibracije su prikazane na slici 2.2.16. Razlika između intenziteta amplituda ova dva signala na osnovnoj frekvenciji je oko 3 reda veličine. Za razliku od strujnog signala, čak i na višim frekvencijama će odnos amplituda ovih signala biti veći od jednog reda veličine. U frekventnom sastavu napona takođe dominira signal na osnovnoj frekvenciji dok je drugi harmonik svega 4 puta manji od osnovnog. Sledeća tri harmonika, u primeru koji je prikazan na slici (450mTorr, 500 W), će imati intenzitete u nivou od oko 1 % osnovnog.

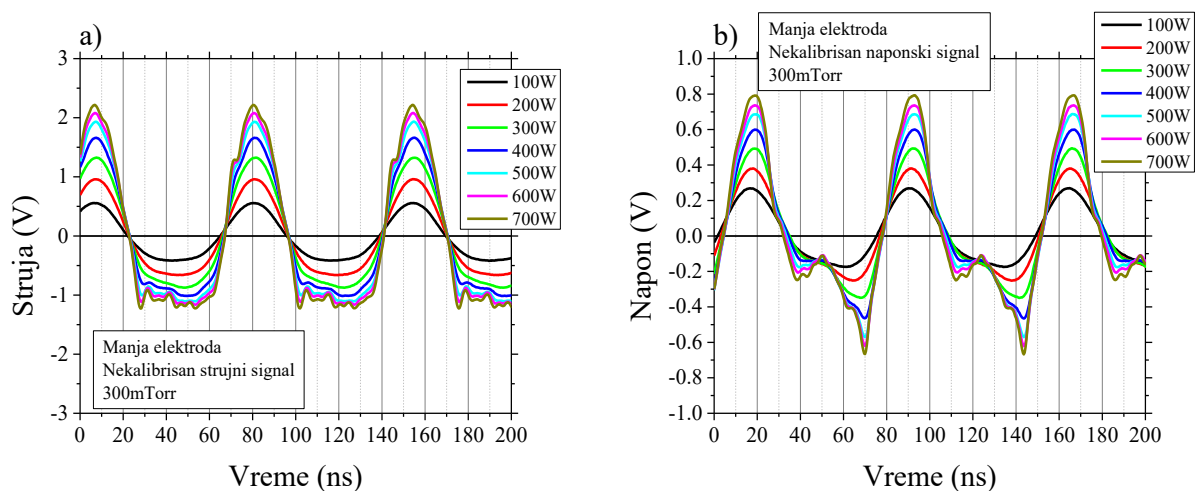

Slika 2.2.17 Strujni i naponski signali, sa postavljenom uzemljenom elektrodom manjeg poluprečnika, dobijeni direktno sa a) strujne i b) naponske sonde na fiksnom pritisku i različitim snagama.

Uticaj primenjene snage na nekalibrisane strujne i naponske signale, koji su snimljeni na pritisku od 300 mTorr, je prikazan na slici 2.17. U situaciji kada je u komori postavljena uzemljena

elektroda manjeg poluprečnika se odstupanje signala od pravilnih sinusoida primećuje na znatno nižim snagama nego kada nje nema. Na strujnim signalima se efekat viših harmonika primećuje već na snazi od 300 W, dok su signali koji su snimljeni kada je primenjena snaga bila veća od 500 W bili potpuno deformisani. Odstupanje od sinusnog oblika, kod naponskih signala, je vidljivo već na 200 W dok se višestruki minimumi i maksimumi pojavljuju na snagama koje su veće od 500 W.

Na slici 2.2.18 je pokazano kako promena primenjene snage utiče na strujne i naponske signale koji su amplitudno i fazno kalibrisani. Suprotno očekivanju ove krive ni nakon kalibracije nemaju oblik pravilnih sinusoida, pogotovo na većim primenjenim snagama. Efekti viših harmonika ili blizine uzemljene elektrode su uočljiviji na naponskim nego na strujnim signalima. Povećanje primenjene snage od 100 do 700 W je na amplitudu struje uticalo tako da je ona porasla sa 1,8 A do 7,5 A. Napon se u istom opsegu snaga povećao od 150 V do 400 V.

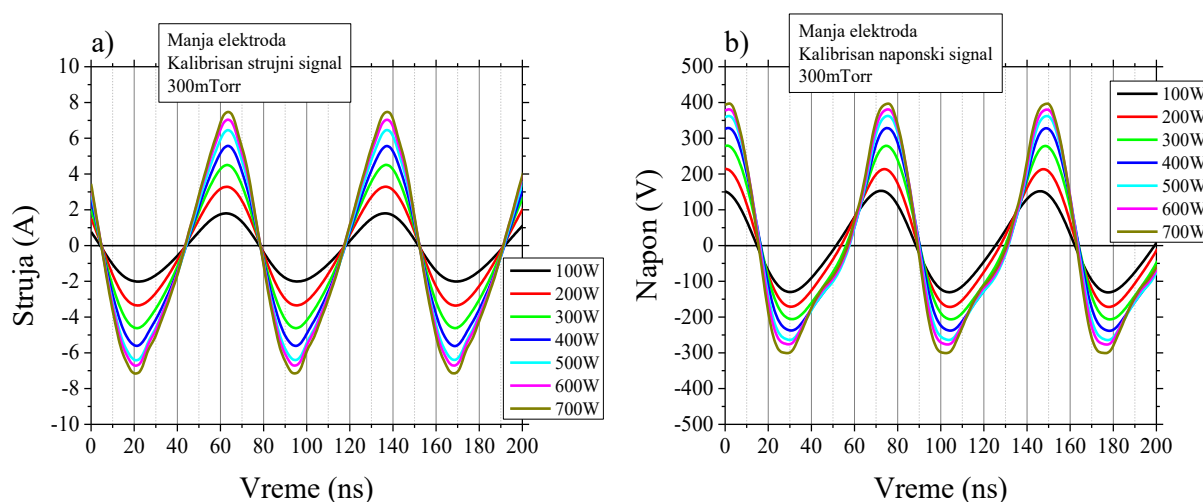

Slika 2.2.18 Vremenska zavisnost a) strujnih i b) naponskih signala nakon fazne i amplitudne kalibracije, na fiksnom pritisku i različitim snagama sa postavljenom uzemljenom elektrodom manjeg poluprečnika.

Efekat primenjene snage na frekventni sastav strujnih i naponskih signala je razmatran i za situaciju kada je u komori bila postavljena uzemljena elektroda manjeg poluprečnika. Na slici 2.2.19 je prikazano kako snaga utiče na intenzitete prvih 6 harmonika strujnih i naponskih signala koji su izmereni direktno na sondama na pritisku od 300 mTorr. Najintenzivniji porast amplituda za sve više harmonike, od trećeg do šestog, se događa između 200 i 300 W posle čega njihov porast usporava. Intenzitet drugog harmonika, sa povećanjem snage, raste ravnomerno u celom opsegu ali znatno brže od osnovnog, pa će i njegov doprinos u ukupnom frekventnom sastavu biti mnogo veći na najvećim primenjenim snagama. Odnosno, može da se kaže da odnos intenziteta prvog i drugog harmonika opada sa porastom nominalne snage.

Asimetrično kapacitivno spregnuto pražnjenje velike zapremine

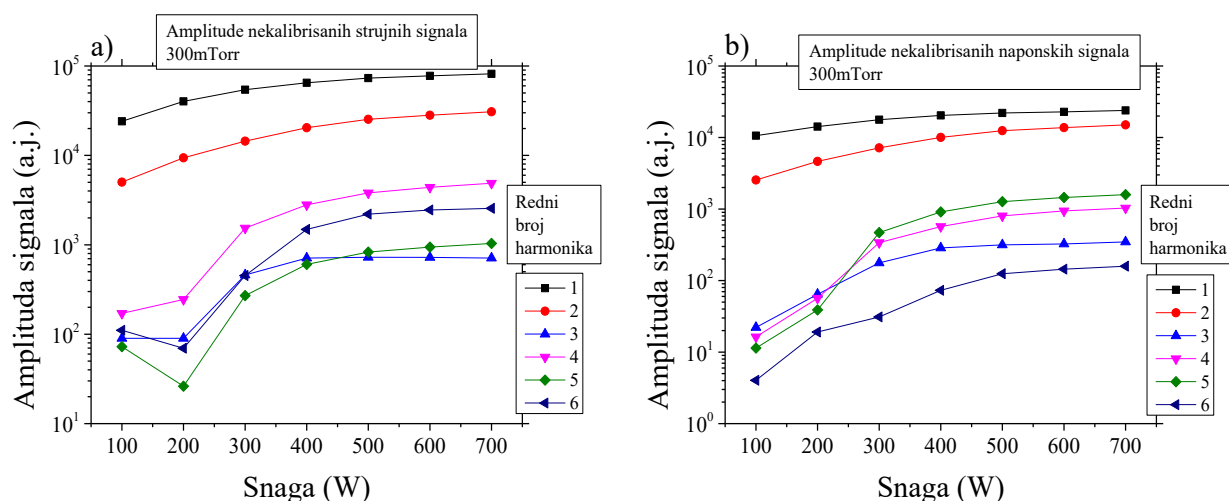

Slika 2.2.19 Amplitude prvih 6 harmonika signala, sa postavljenom uzemljenom elektrodom manjeg poluprečnika, koji su dobijeni direktno sa a) strujne i b) naponske sonde.

Frekventni sastav kalibriranih strujnih i naponskih signala u zavisnosti od primenjene snage je prikazan na slici 2.2.20. Njihov nepravilan oblik u vremenskom domenu (slika 2.2.18) može i u ovom slučaju da se objasni porastom intenziteta amplituda na višim frekvencijama. Najveći doprinos, pored osnovnog, ima drugi harmonik. Kod strujnog signala će na snazi od 100 W osnovni harmonik biti 11 puta intenzivniji od drugog. Na snazi od 700 W će odnos njihovih intenziteta biti oko 6. Kod naponskih signala, kod kojih je u vremenskom domenu odstupanje od pravilnih sinusoida uočljivije, će odnos prvog i drugog harmonika na 100 W iznositi 7,9 dok će na 700 W osnovni harmonik biti svega tri puta intenzivniji od drugog. Intenzitet viših harmonika će takođe rasti sa povećanjem snage i to tako da će u merenom opsegu snaga određeni harmonici postati i stotinak puta intenzivniji. Međutim, čak i na najvećim primenjenim snagama najintenzivniji od njih će i dalje biti oko dva reda veličine slabiji od osnovnog harmonika. Ovim smo pokazali da do distorzije vremenskih signala na većim snagama dolazi zbog porasta doprinosa drugog harmonika u frekventnom sastavu, kako strujnih tako i naponskih, signala.

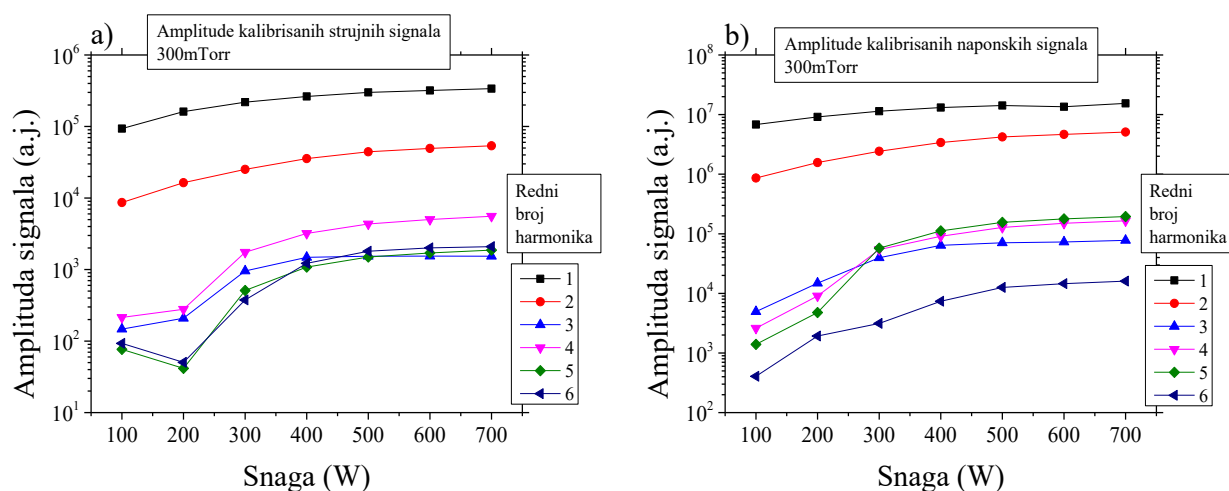

Slika 2.2.20 Amplitude prvih 6 harmonika a) strujnog i b) naponskog signala, sa postavljenom uzemljenom elektrodom manjeg poluprečnika, nakon množenja vrednosti sa kalibracionih krivi.

Asimetrično kapacitivno spregnuto pražnjenje velike zapremine

Promena pritiska ima mali efekat na promenu struje. Na slici 2.2.21 a) se vidi da je sa fiksnom snagom od 700 W ta promena manja od 10 %. Sa druge strane, promenom pritiska sa 300 na 600 mTorr na fiksnoj snazi od 700 W dolazi do ukupne promene u naponu od preko 30 %, što je prikazano na slici 2.2.21 b).

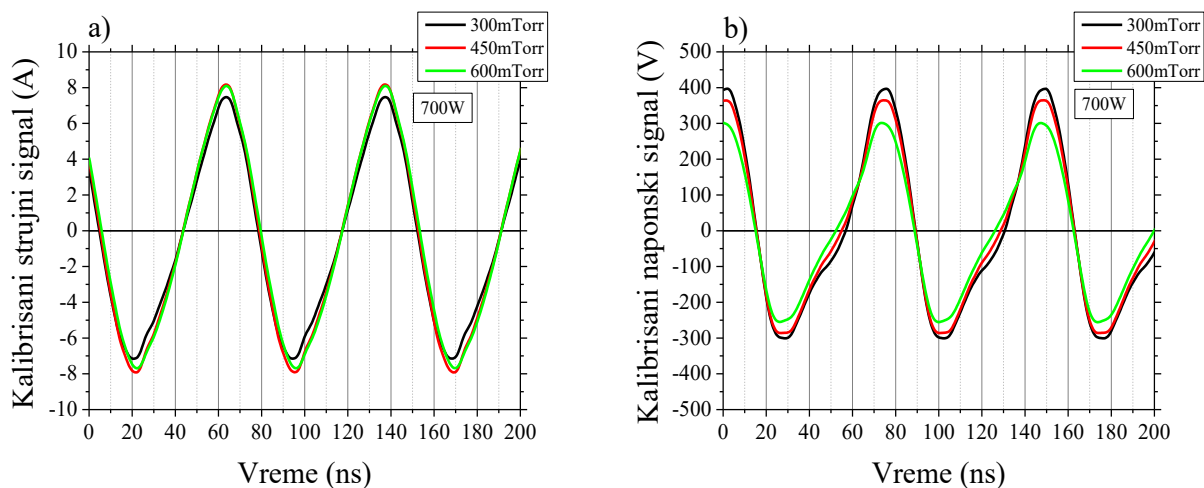

Slika 2.2.21 Promena kalibrisanih signala a) struje i b) napona u zavisnosti od pritiska, za snagu 700 W predatu RF izvorom

I u slučaju uzemljene elektrode manjeg poluprečnika efekat promene pritiska na frekventni sastav struje i napona će biti prikazan samo za prva dva harmonika s obzirom da svi viši harmonici i u ovom slučaju doprinose manje od nekoliko procenata u ukupnom signalu. Kao što se vidi na slici 2.2.22 a), u najvećem delu primenjenih snaga intenzitet osnovnog harmonika strujnog signala raste sa povećanjem pritiska. Drugi harmonik se ponaša potpuno suprotno i u celom opsegu snaga njegov intenzitet opada sa povećanjem pritiska. Sa druge strane, kod naponskog signala intenzitet oba harmonika opada sa povećanjem pritiska.

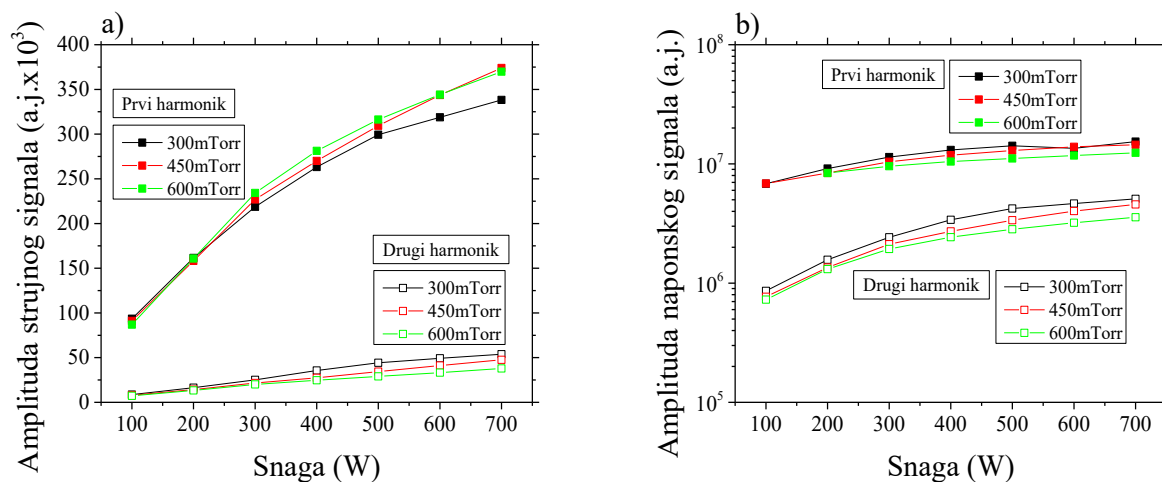

Slika 2.2.22 Zavisnost intenziteta prvog i drugog harmonika kalibrisanog signala a) struje i b) napona od nominalne snage i pritiska, uzemljena elektroda manjeg poluprečnika

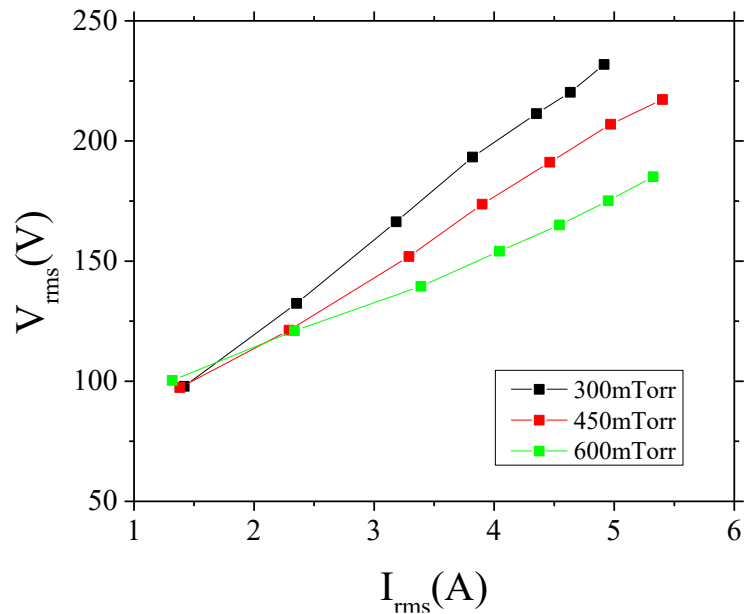

Slika 2.2.23 I_{rms} - V_{rms} karakteristika sistema sa uzemljenom elektrodom manjeg poluprečnika. Svaka tačka predstavlja jedan par I_{rms} - V_{rms} vrednosti dobijenih na istoj snazi

Zavisnost RMS vrednosti napona od struje je prikazana na slici 2.2.23. Isto kao i za slučaj uzemljene elektrode većeg poluprečnika, svaka tačka na grafiku predstavlja jedan par I_{rms} - V_{rms} vrednosti za nominalne snage pražnjenja od 100 do 700 W i korakom od 100 W. Može da se primeti da I_{rms} vrednosti skoro uopšte ne zavise od pritiska na kome je merenje vršeno a nalaze se u opsegu od 1,3 A do 5,4 A. S druge strane, promena pritiska će značajno uticati na RMS vrednosti napona. Na svim primenjenim snagama, osim na 100 W, napon će biti veći ukoliko je merenje urađeno na manjem pritisku. Najveća V_{rms} vrednost, od 234 V, je dobijena na pritisku od 300 mTorr i snazi od 700 W. S obzirom na to da je zavisnost $V_{rms}(I_{rms})$ linearna i da sa povećanjem snage dolazi do značajnog porasta i struje i napona, može da se zaključi da je pražnjenje u α režimu. U celom opsegu snaga i pritisaka, kada je u komori postavljena dodatna uzemljena elektroda, ne dolazi do promene režima, odnosno ne dolazi do prelaska u γ režim. U ovakvoj geometriji sistema impedansa plazme će opadati sa povećanjem pritiska. Na 300 mTorr ona iznosi $38,6 \pm 0,5 \Omega$, na 450 mTorr je $30,6 \pm 0,6 \Omega$ dok je impedansa plazme na pritisku od 600 mTorr $20,8 \pm 0,6 \Omega$.

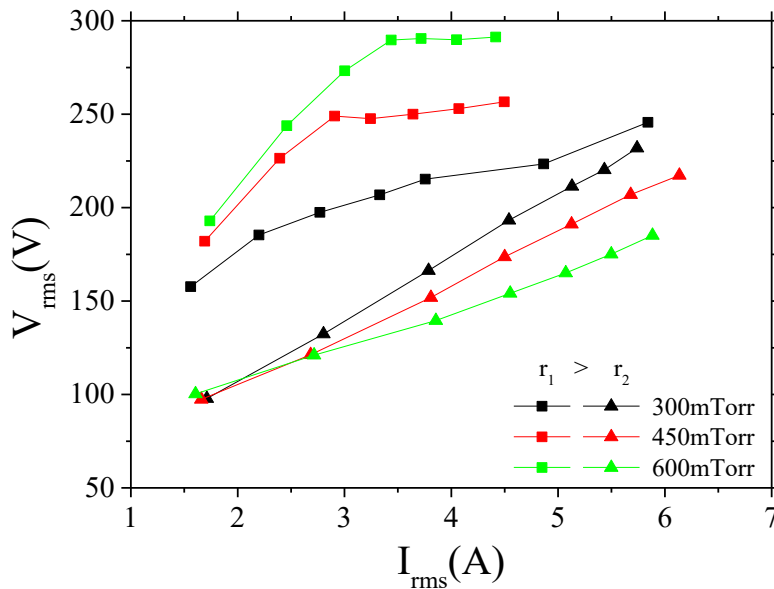

Slika 2.2.24 Poređenje I_{rms} - V_{rms} vrednosti sistema koje su dobijene sa različitim uzemljenim elektrodama. Pritisci su obeleženi različitim bojama i to crnom 300 mTorr, crvenom 450 mTorr i zelenom 600 mTorr. Kvadratima su obeležene vrednosti dobijene korišćenjem uzemljene elektrode većeg poluprečnika (r_1) a trouglom dobijene uzemljenom elektrodom manjeg poluprečnika (r_2)

Kako bi se uporedile strujno naponske karakteristike koje su dobijene sa jednom i sa drugom uzemljenom elektrodom na slici 2.2.24. su prikazane I_{rms} - V_{rms} krive dobijene u oba slučaja. Vrednosti napona su veće u slučaju kada je korišćena uzemljena elektroda većeg poluprečnika, dok su maksimalne vrednosti struje za datu snagu RF izvorom manje. U određenim slučajevima vrednosti napona sa većom uzemljenom elektrodom su veće i do 60 %. Kao što je već bilo reči do sada iz V_{rms} - I_{rms} krivi se vidi da u slučaju manje uzemljene elektrode pražnjenje ostaje u α modu za sve vrednosti primenjene snage a u slučaju veće vidimo prelaz iz α moda u γ mod. Zavisnost V_{rms} - I_{rms} od pritiska je različita u ove dve geometrije. Kad je u pitanju manja uzemljena elektroda naponi potrebni za održavanje pražnjenja opadaju sa porastom pritiska. U slučaju veće uzemljene elektrode oni rastu.

Efikasnost predaje snage plazmi, kada je u sistem postavljena uzemljena elektroda manjeg poluprečnika, predstavljena je na slici 2.2.25 i razmotrićemo ukratko kako se ponaša na svakom pojedinačnom pritisku. Dakle, na najmanjem pritisku od 300 mTorr dolazi do opadanja efikasnosti sa porastom primenjene snage. Osim na najmanjim nominalnim snagama, tokom merenja sa dodatnom uzemljenom elektrodom sistem je bio najneefikasniji upravo na pritisku od 300 mTorr. Minimum efikasnosti je dobijen na 600 W nominalne snage i iznosi 85 %. Na pritisku od 450 mTorr se nalazi najupečatljivija karakteristika efikasnosti predaje snage plazmi u zavisnosti od nominalne snage. Naime, na najmanjim snagama, od 100 i 200 W, zabeležena je i najmanja efikasnost upravo na 450 mTorr. Međutim, već na 300 W dolazi do naglog skoka pa je na toj i svim višim primenjenim snagama sistem najefikasniji na pritisku od 450 mTorr. Ukupni maksimum je postignut na snazi od 700 W i iznosi 99 %. Na najvećem pritisku efikasnost brzo raste sve do snage od 300 W, gde se nalazi lokalni maksimum od oko 97 %. Nakon te snage efikasnost ostaje praktično konstantna.

Asimetrično kapacitivno spregnuto pražnjenje velike zapremine

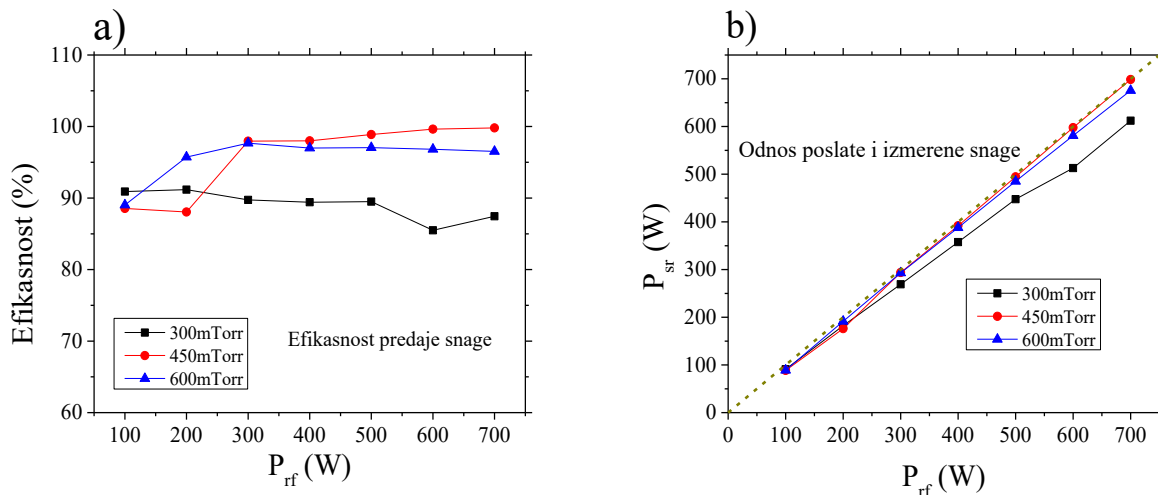

Slika 2.2.25 Efikasnost sistema sa uzemljenom elektrodom manjeg poluprečnika predstavljena kao a) procenat nominalne snage i b) izmerena snaga na napajanoj elektrodi u zavisnosti od nominalne snage generatora

Poređenje efikasnosti sistema, sa uzemljenim elektrodama različitih poluprečnika, u zavisnosti od nominalne snage generatora je grafički predstavljeno na slici 2.2.26. Može da se primeti da će u uslovima najmanjeg pritiska i najveće primenjene snage, slično kao za $I_{rms}-V_{rms}$ karakteristiku sistema, pražnjenje imati skoro identičnu vrednost za obe geometrije. U oba slučaja ona iznosi oko 87 %. Takođe, jedino na ovom pritisku, u oba slučaja, ne postoji porast efikasnosti sa porastom primenjene snage. Još jedna zajednička osobina sistema za obe uzemljene elektrode je ta da je sistem, na velikim snagama, bio najefikasniji na pritisku od 450 mTorr. Razlike u efikasnosti sistema su uočljivije na većim pritiscima. Evidentno je da je ukupna efikasnost, u celom opsegu snaga, veća za uzemljenu elektrodu manjeg poluprečnika ali i da se glavni skok efikasnosti, na toj elektrodi, događa na nominalnim snagama između 100 i 300 W. S druge strane, u sistemu bez dodatne uzemljene elektrode će efikasnost ravnomerno rasti sa povećanjem primenjene snage.

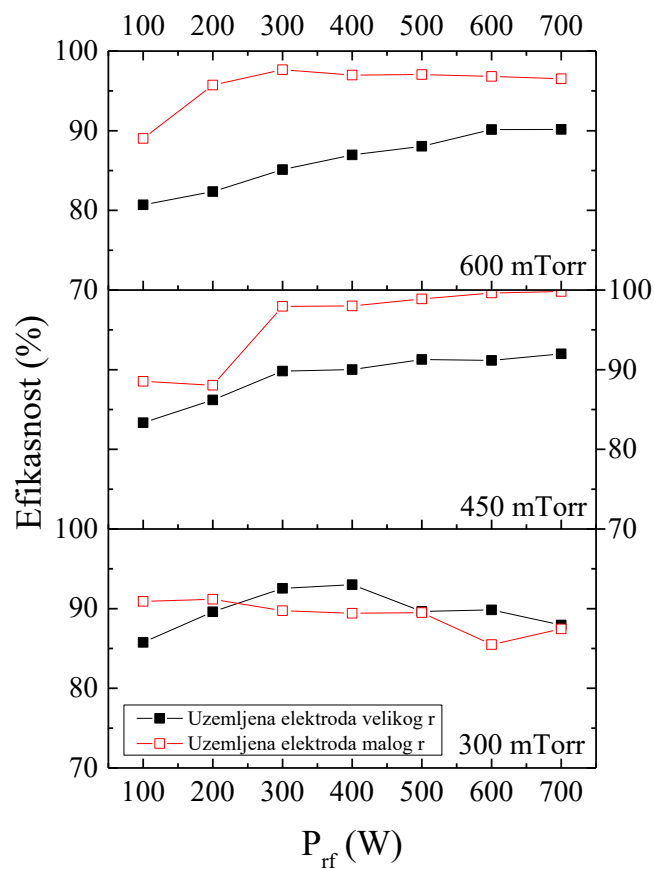

Slika 2.2.26 Poređenje efikasnosti sistema sa uzemljenim elektrodama različitih poluprečnika (r) u zavisnosti od nominalne snage (P_{rf}) na sva tri različita pritiska.

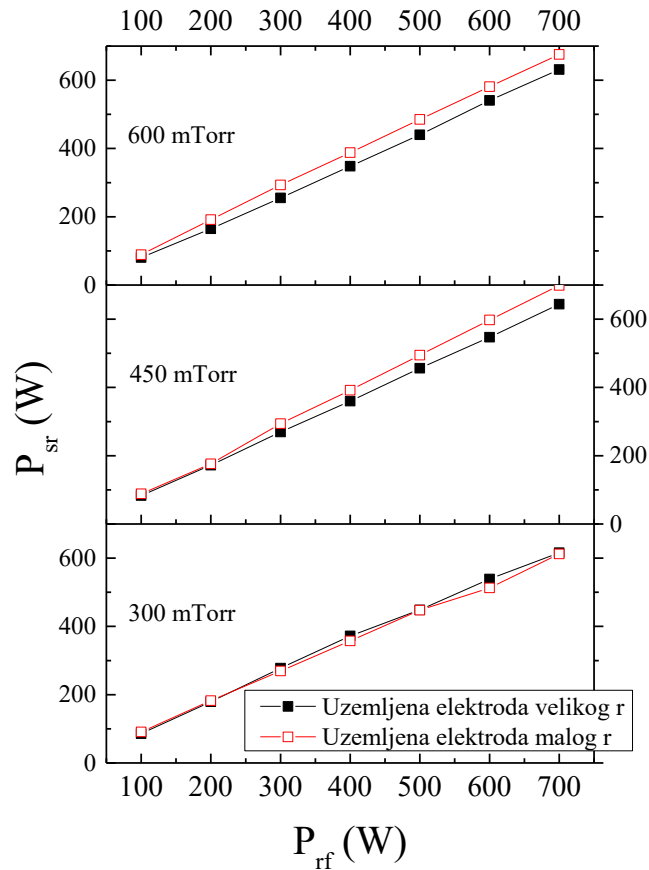

Slika 2.2.27 Poređenje izmerene snage (P_{sr}) u sistemu sa uzemljenim elektrodama različitih poluprečnika (r) u zavisnosti od nominalne snage (P_{rf}) na sva tri različita pritiska.

Poređenje sistema u situaciji kada je u njemu bila postavljena dodatna elektroda i kada nje nema, može da se predstavi i na drugačiji način. Zavisnost izmerene snage na napajanoj elektrodi u funkciji od nominalne snage generatora, za dve različite uzemljene elektrode, je prikazana na slici 2.2.27. Iako su razlike sada nešto manje uočljive, jasno je da je izmerena snaga veća kada je korišćena uzemljena elektroda manjeg poluprečnika.

S obzirom na to da se derivativne sonde nalaze na samoj napajanoj elektrodi, gubici u kontaktima praktično ne postoje. Takođe, kod cilindrične geometrije su efekti krajeva svedeni na minimum, jer se napajana elektroda nalazi u unutrašnjosti uzemljene pa neće dolaziti do rasipanja energije u prostor u kome ne dolazi do pražnjenja. Ipak, određeni toplotni gubici postoje i naša pretpostavka je da je najveći deo gubitaka upravo toplotne prirode.

U jednom od prvih radova koji je vezan za upotrebu derivativnih sondi, i Miler se osvrnuo i na harmonijski sastav [44] struje i napona. Ta merenja su obavljena u komori plan paralelne geometrije, GEC tipa. Doprinosi viših harmonika, pogotovo drugog, su bili značajno veći nego što je dobijeno u našim merenjima. Zavisno od uslova, odnosno od dužine napajanih kablova, dobio je da se intenzitet drugog harmonika naponskog signala kreće od svega nekoliko procenata pa do 40 % vrednosti osnovnog harmonika. Intenzitet drugog harmonika strujnog signala je varirao u jako širokom opsegu. U specifičnim uslovima merenja osnovni i drugi harmonik su imali identične vrednosti. Ipak, u najvećem broju merenja se intenzitet drugog harmonika kretao oko 30 % vrednosti osnovnog. U nešto novijem radu su sličnim mernim metodama Bora et al [138], takođe u plan paralelnom reaktoru ali asimetrične geometrije, dobili da je drugi harmonik struje znatno intenzivniji od prvog. Ono što je zanimljivo, njihove RMS vrednosti napona su opadale sa povećanjem pritiska,

što je situacija slična našoj kada je u komori postavljena uzemljena elektroda manjeg poluprečnika. U radu iz 2020. Ravat (Rawat) je takođe analizirao frekventni sastav pražnjenja [139]. Posle osnovnog, najdominantniji je bio treći harmonik koji je bio oko pet puta manje intenzivan od osnovnog, praćen drugim koji je bio još upola manji. Može se primetiti da frekventni sastav struje i napona u pražnjenju zavisi od mnogo faktora, poput geometrije reaktora i dužine kablova. Poredeći naša merenja sa dve dostupne geometrije i sa rezultatima pomenutih autora nameće se zaključak da smo smanjivanjem poluprečnika uzemljene elektrode dobili rezultate koji su mnogo sličniji plan paralelnoj geometriji, s tim što je u svim našim merenjima dominantan bio osnovni harmonik. Međutim kada dodatna elektroda nije bila postavljena, frekventni sastav je bio znatno „čistiji“, odnosno efekti viših harmonika su bili primetni tek na najvećim primenjenim snagama, kada je drugi harmonik struje dostizao 11 % vrednosti osnovnog dok je kod naponskog signala dostizao 18 %.

U ovom sistemu su već rađena merenja efikasnosti ali u nešto manjem opsegu snaga i pritiska. Bez dodatne elektrode, i kada je u komori bio vazduh, postignuta je efikasnost od oko 70 % na primenjenim snagama između 50 i 300 W [45]. Godiak (Godyak) se takođe bavio procenom efikasnosti predaje snage plazmi. U jednom od najstarijih radova na tu temu je za plan paralelnu geometriju, u širokom opsegu snaga, dobio efikasnost između 40 i 75 % na pritisku od 0,01 Torr i između 80 i 90 % za pritisak od 1 Torr, koji je bliži našim eksperimentalnim uslovima. Najveća nominalna snaga u njegovom eksperimentu i najmanja u našem iznosi 100 W i zanimljivo je da su pri tim uslovima dobijene slične efikasnosti od oko 85 %. U potpuno drugačijoj vrsti reaktora Minea i saradnici su takođe ispitivali efikasnost sistema na frekvenciji od 13,56 MHz [140]. U pitanju je magnetno konfinirana plazma ali je ispitivano, između ostalog, kako će postavljanje različite vrste mete uticati na predaju snage plazmi. Naime, u jednom slučaju se ispod magnetrona nalazila provodna meta od bakra, dok je u drugom slučaju ona bila napravljena od boron nitrida koji je izolator. Paralela može da se povuče sa našim eksperimentom u smislu da je, u situaciji kada je korišćena uzemljena elektroda većeg poluprečnika, naša plazma, u najvećem broju parametara poput snage i pritiska, s jedne strane bila ograničena napajanjem elektrodom a sa druge strane neprovodnim neutralnim gasom. Naime i kod magnetrona, na istoj frekvenciji, i u našim eksperimentima, je predaja snage plazmi bila manje efikasna kada se između uzemljene elektrode i aktivnog dela plazme nalazio izolator. Takođe, kada se sa druge strane nalazila provodna meta odnosno provodna uzemljena elektroda manjeg poluprečnika, efikasnost predaje snage je bila velika.

Nameće se zaključak da do porasta struje i efikasnosti u merenjima koja su rađena kada je u sistemu bila postavljena uzemljena elektroda manjeg poluprečnika dolazi upravo iz razloga što će u takvoj geometriji formiranje prielektrodne oblasti, na uzemljenoj elektrodi, biti moguće i na velikim pritiscima ali i sa malim primenjenim snagama. S druge strane, kada je bila korišćena uzemljena elektroda velikog poluprečnika, osim pri najmanjim pritiscima i najvećim snagama, ulogu uzemljene elektrode je, slično kao i kod atmosferskih plazmi, preuzimao okolni gas. Treba imati u vidu da je reflektovana snaga u svakom trenutku bila ispod 1 % nominalne snage (P_{rf}) što znači da je greška, koju bi u rezultate merenja mogla da unese reflektovana snaga, minimalna i da ona ne može da utiče na zaključke koji su doneti u vezi električnih osobina ovog sistema.

2.2.1.3 Zaključak

Derivativnim sondama su ispitivane električne osobine pražnjenja u konfiguracijama sa dve različite uzemljene elektrode. Iako postoje određene sličnosti, unošenje dodatne elektrode dovodi do promena u ponašanju sistema. Prikazan je način obrade podataka i ispitano je kako faktori poput pritiska i nominalne snage utiču na struju, napon, njihov frekventni sastav, RMS vrednosti i efikasnost sistema. Ustanovljeno da je oblik signala u vremenskom domenu znatno nepravilniji kada je u komori bila postavljena dodatna uzemljena elektroda. Do ovoga dolazi zbog većeg doprinosa viših harmonika u frekventnom sastavu kako strujnog tako i naponskog signala. Uočeno je da, pored

osnovnog, najveći doprinos ukupnom spektru dolazi od drugog harmonika dok intenzitet ostalih retko prelazi 1 % intenziteta osnovnog harmonika. Pokazali smo da odabir uzemljene elektrode značajno utiče i na I_{rms} - V_{rms} karakteristike sistema. Smanjivanje prečnika uzemljene elektrode je dovelo do pada RMS vrednosti napona, ali su RMS vrednosti struje značajno porasle. U najvećem opsegu parametara pražnjenja, promena pritiska nije imala značajan efekat na RMS vrednosti struje. S druge strane, promene pritiska su dovodile do velikih promena RMS vrednosti napona. Zanimljivo je da je pritisak potpuno suprotno uticao na napon zavisno od toga koja je elektroda bila korišćena. Naime tokom merenja bez dodatne uzemljene elektrode je povećanje pritiska dovodilo do povećanja napona, dok je sa dodatnom uzemljenom elektrodom veća RMS vrednost napona zabeležena na manjem pritisku. Promena pritiska nije imala značajan efekat na struju, dok je na RMS vrednosti napona imala potpuno suprotan efekat, zavisno od toga koja je uzemljena elektroda korišćena. Efikasnost predaje plazmi je bila znatno veća kada je korišćena uzemljena elektroda manjeg poluprečnika. Jedan od razloga za razlike u ponašanju sistema u ove dve geometrije leži i u činjenici da je kapacitivnost komore u jednoj konfiguraciji iznosila 15,7 pF dok je u drugoj bila 50 pF. Međutim, ova promena ipak ne može da objasni sve razlike. Poređenjem rezultata koje smo dobili u našim merenjima, međusobno i sa rezultatima autora iz dostupne literature, zaključili smo da se klasična prielektrodna oblast na uzemljenoj elektrodi, u najvećem opsegu parametara pražnjenja, praktično i „ne formira“ kada je korišćena uzemljena elektroda velikog poluprečnika, već je plazma skoncentrisana u delu prostora oko napajane elektrode. Tokom pražnjenja u tim uslovima, ulogu uzemljene elektrode preuzima neutralni gas koji okružuje plazmu. Sa druge strane kada je bila postavljena dodatna uzemljena elektroda, pražnjenje je u skoro svim uslovima bilo takvo da je dolazilo do formiranja prielektrodne oblasti na njoj, odnosno plazma je ispunjavala ceo prostor između elektroda. Slične uslove pražnjenja, za različite uzemljene elektrode, je moguće dobiti samo na najmanjem pritisku i najvećoj nominalnoj snazi i tada su u obe geometrije dobijene skoro identične RMS vrednosti napona i struje ali i efikasnosti sistema.

2.2.2 SIMULACIJA PROTOKA U ASIMETRIČNOM REAKTORU VELIKE ZAPREMINE

S obzirom na to da su tokom eksperimenata u asimetričnom reaktoru merenja rađena u dve različite geometrije, sa i bez dodatne uzemljene elektrode, bilo je poželjno proveriti da li i kako ova promena utiče na kretanje gasova i njihovu prisutnost u različitim delovima komore. Drugim rečima, zanimalo nas je da li ova promena geometrije sistema može da dovede do promena u uslovima pražnjenja. Mesta od posebnog interesa su oblast oko napajane elektrode gde nastaju aktivne čestice i pozicija na kojoj maseni spektrometar prikuplja čestice za dalju analizu. Imajući u vidu obim i temu ove disertacije, problemom protoka gasova smo se pozabavili na nešto grubljem nivou, upotrebom dvodimenzionalne aproksimacije.

Za tu svrhu je upotrebljen komercijalno dostupan Flowsquare softverski paket koji je besplatan ukoliko se koristi za dvodimenzionalne analize. Iako relativno skromnih mogućnosti, ovaj paket može da se koristi za simuliranje kretanja robota pod vodom [141], modeliranje protoka krvi kroz vene [142], procenu efikasnosti fotokatalizatora u uklanjanju polutanata iz vazduha [143] ali je svoju primenu pronašao čak i u arheologiji [144].

Zavisno od potrebe je moguće primeniti jedan od 4 različita režima simulacije. Iako postoje režimi koji su namenjeni za analizu situacija u kojima dolazi do sagorevanja gasova, neke druge vrste reakcije među njima ili u kojima se pojavljuju oblasti u kojima se fluid kreće nadzvučnom brzinom, za naše proračune je upotrebljen najjednostavniji režim koji podrazumeva protok gasa bez hemijskih reakcija. U tom slučaju se problem svodi na rešavanje jednačine kontinuiteta [145]:

$$\frac{\partial \rho}{\partial t} + \frac{\partial}{\partial x_i} (\rho u_i) = 0, \quad (2.11)$$

i jednačine impulsa:

$$\frac{\partial}{\partial t} (\rho u_j) + \frac{\partial}{\partial x_i} (\rho u_i u_j) = -\frac{\partial p}{\partial x_j} + \frac{\partial \tau_{ij}}{\partial x_i} + (\rho - \rho_\infty) g_j. \quad (2.12)$$

U ovim jednačinama se indeksi i i j odnose na smerove duž različitih osa, sa x je obeležena koordinata a sa u brzina dok je gustina fluida označena slovom ρ . Sa desne strane jednačine 2.12 se pored pritiska nalazi i faktor potiska koji postoji usled delovanja sile gravitacije na fluide različitih gustina ali i viskozni član koji je obeležen slovom τ .

Jednačina 2.12 se rešava u dva koraka. U prvom koraku se razmatra jednačina bez faktora vezanih za pritisak, odnosno rešava se jednačina u sledećem obliku:

$$\frac{\partial}{\partial t} (\rho u_j)^* = -\frac{\partial}{\partial x_i} (\rho u_i u_j) + \frac{\partial \tau_{ij}}{\partial x_i} + (\rho - \rho_\infty) g_j. \quad (2.13)$$

U drugom koraku se uključuje faktor pritiska tako što se vremenski integrali sledeća jednačina:

$$\frac{\partial}{\partial t} (\rho u_j) = -\frac{\partial p^*}{\partial x_j}. \quad (2.14)$$

Na osnovu ovih podataka se zatim pristupa rešavanju Poasonove jednačine kako bi se dobile vrednosti korigovanog pritiska:

$$\frac{\partial^2 p}{\partial x_i^2} = \left(\frac{\partial}{\partial x_j} (\rho u_j)^* + \frac{\partial \rho}{\partial t} \omega_d \right) * \frac{1}{\Delta t}. \quad (2.15)$$

Ovde je sa ω_d obeležen faktor koji se podešava od strane korisnika, dok je vremenski korak simulacije označen sa Δt . U poslednjem koraku, u ovom režimu rada, se izračunava brzina fluida preko sledeće formule:

$$\rho u_j = (\rho u_j)^* - \frac{\partial p^*}{\partial x_j} \Delta t. \quad (2.16)$$

Pre početka svake simulacije je potrebno definisati prostor u kome se gasovi kreću. Da bi se to postiglo, mora da se napravi bmp fajl, odnosno slika, u okviru koga se bojama definišu posebne oblasti i granični uslovi. Crnom bojom su označene površine kroz koje gas ne može da prođe, plavom je označeno mesto na kome gasovi ulaze, dok se crvenom obeležava mesto na kome oni izlaze. Prostor u kome je planirano slobodno kretanje fluida treba da ostane beo. Na slici 2.2.28 je prikazan primer slike koju smo koristili za simulaciju protoka kada je u komori bila postavljena dodatna uzemljena elektroda. Prilikom pravljenja ovog crteža je vođeno računa o tome da proporcije prostora i svih relevantnih rastojanja odgovaraju realnim dimenzijama reaktora. S obzirom na to da je predstavljen jedan presek duž centralne ose simetrije, na slici se ne nalazi napajana elektroda. Imajući u vidu njene dimenzije i poziciju, pretpostavili smo da ona ne utiče značajno na kretanje fluida. Između dodatne elektrode, koja je predstavljena sa dve linije u sredini crteža, i samog zida komore je ostavljen prostor kako bi gasovi mogli da se kreću tom delu „zapremine“, što je situacija koja odgovara realnosti jer uzemljena elektroda manjeg poluprečnika ne naleže savršeno na zid komore. Prekidom linije na donjoj strani dodatne uzemljene elektrode je predstavljena rupa na njenoj površini koja je tokom konstrukcije napravljena kako bi napajana elektroda ostala vidljiva (dostupna) za optička merenja.

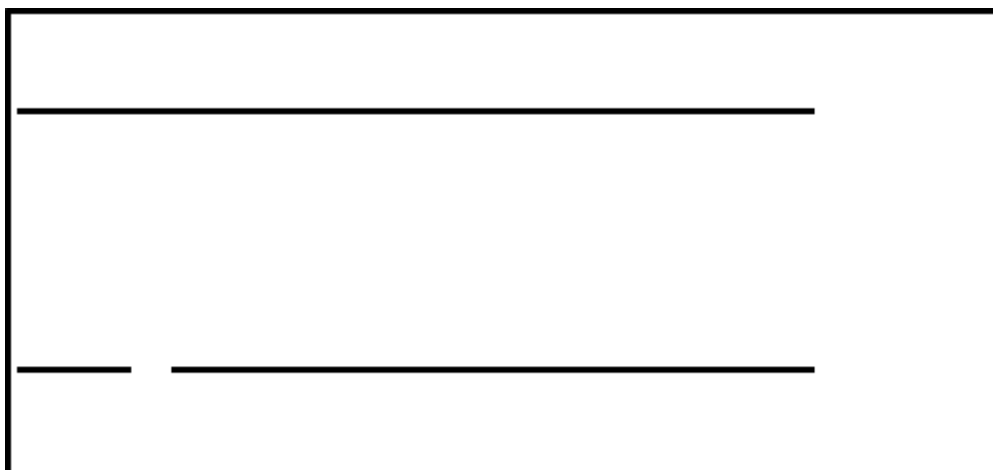

Slika 2.2.28 Ulazni fajl za flowsquare simulaciju na kome je predstavljen jedan presek asimetričnog reaktora. Plavom bojom je označeno mesto na kome gasovi ulaze dok je crvenom označeno mesto na kome oni napuštaju komoru.

Pored pomenute slike, pre početka simulacije je potrebno pripremiti još i tekstualni fajl koji ima unapred definisanu formu (grid.txt) a u kome se nalaze svi ostali podaci koji su potrebni za proračun. Među najvažnijim parametrima se nalaze brzine kojima gasovi u komoru ulaze i iz nje izlaze. U korišćenom režimu simulacije je moguće definisati vrednosti za samo jedan gas. Zbog toga smo za svaki pritisak sabrali ukupni protok argona i kiseonika, koji je na protokomerima zabeležen tokom eksperimenata, čime smo dobili totalnu zapreminu gasa koja u komoru ulazi u jedinici vremena (sccm). S obzirom da tokom eksperimenata ne dolazi do promene pritiska, ne menja se količina gasa, ista vrednost je uzeta i kao zapremina koja iz komore izlazi. Da bi se zapreminski protok preračunao za brzinu je korišćena relacija: $\frac{V}{t} = s * v$, gde je sa V obeležena zapremina, sa s površina otvora kroz koji gasovi ulaze i izlaze a sa v njihova brzina. U proračunu su korišćene iste vrednosti za dimenzije ulaznog i izlaznog otvora, iako je ulazno mesto nešto uže. Za vrednost prečnika od 5 cm je dobijena površina od 0,00196 m². Dodatno, potrebno je uneti i gustinu gasa. Ona je računata iz osnovne formule $PV=nRT$, gde je iskorišćena definicija da je $n=m/M$. S obzirom na to da je ulazna smeša sačinjena od 99 % molekulskog kiseonika, korišćena je njegova molarna masa odnosno 0,032kg/mol. Konačno, gustina se dobija jednačine $\frac{V}{m} = \frac{RT}{PM}$ odnosno $\rho = \frac{PM}{RT}$ gde je za univerzalnu gasnu konstantu uzeta vrednost od 8,31mol⁻¹K⁻¹ a za temperaturu 300 K. U tabeli 2.2.1 su prikazane vrednosti svih parametara koje su korišćene u računju.

Tabela 2.2.1 Vrednosti najvažnijih parametara koji su korišćeni prilikom simulacije protoka u asimetričnom reaktoru za tri različita pritiska.

p mTorr	p Pa	protok sccm	protok m ³ /s	v m/s	ρ kg/m ³
300	40	212	0,00000359	0,00183	0,000513
450	60	394	0,00000656	0,00335	0,00077
600	80	576	0,00000960	0,004898	0,001

Pored fizičkih veličina kojima se opisuje stanje sistema potrebno je, u istom fajlu, odabrati i podesiti određene vrednosti koje se tiču samih numeričkih procedura. U našim simulacijama su korišćene jednačine drugog reda u kombinaciji sa LW (Lax-Wendroff) metodom. Sa ovakvim odabirom se prostorno diferenciranje u i -tom smeru u tački prostora sa rednim brojem j obavlja kao:

Asimetrično kapacitivno spregnuto pražnjenje velike zapremine

$$\left(\frac{\partial f}{\partial x_i}\right)_i = (f_{j+1} - f_{j-1})/(2\Delta x_i), \quad (2.17)$$

odnosno kao:

$$\left(\frac{\partial f}{\partial x_i}\right)_1 = -(f_1 - f_2)/\Delta x_i, \quad (2.18)$$

ili u opštem obliku:

$$\left(\frac{\partial f}{\partial x_i}\right)_N = (f_N - f_{N-1})/\Delta x_i. \quad (2.19)$$

Promena nekog parametra f kroz vreme se računa primenom LW metoda kao integral u dva koraka:

$$f'_n = f_n + \frac{\partial f_n}{\partial t} \frac{\Delta t}{2} \quad (2.20)$$

i

$$f_{n+1} = f'_n + \frac{\partial f'_n}{\partial t} \Delta t. \quad (2.21)$$

Važno je naznačiti da je ovaj softverski paket relativno osetljiv na odabir numeričkih parametara poput vremenskog i prostornog koraka i vrednosti određenih numeričkih filtera. Pogrešnim odabirom ovih veličina dolazi do divergencije. Tada postaje nemoguće da se iz prethodno dobijenih rezultata izračunaju vrednosti u sledećem vremenskom koraku i dolazi do prekida simulacije. Vrednosti koje smo mi odabrali su rezultat velikog broja pokušaja da se dobiju najprecizniji rezultati a da simulacija ne počne da divergira.

Asimetrično kapacitivno spregnuto pražnjenje velike zapremine

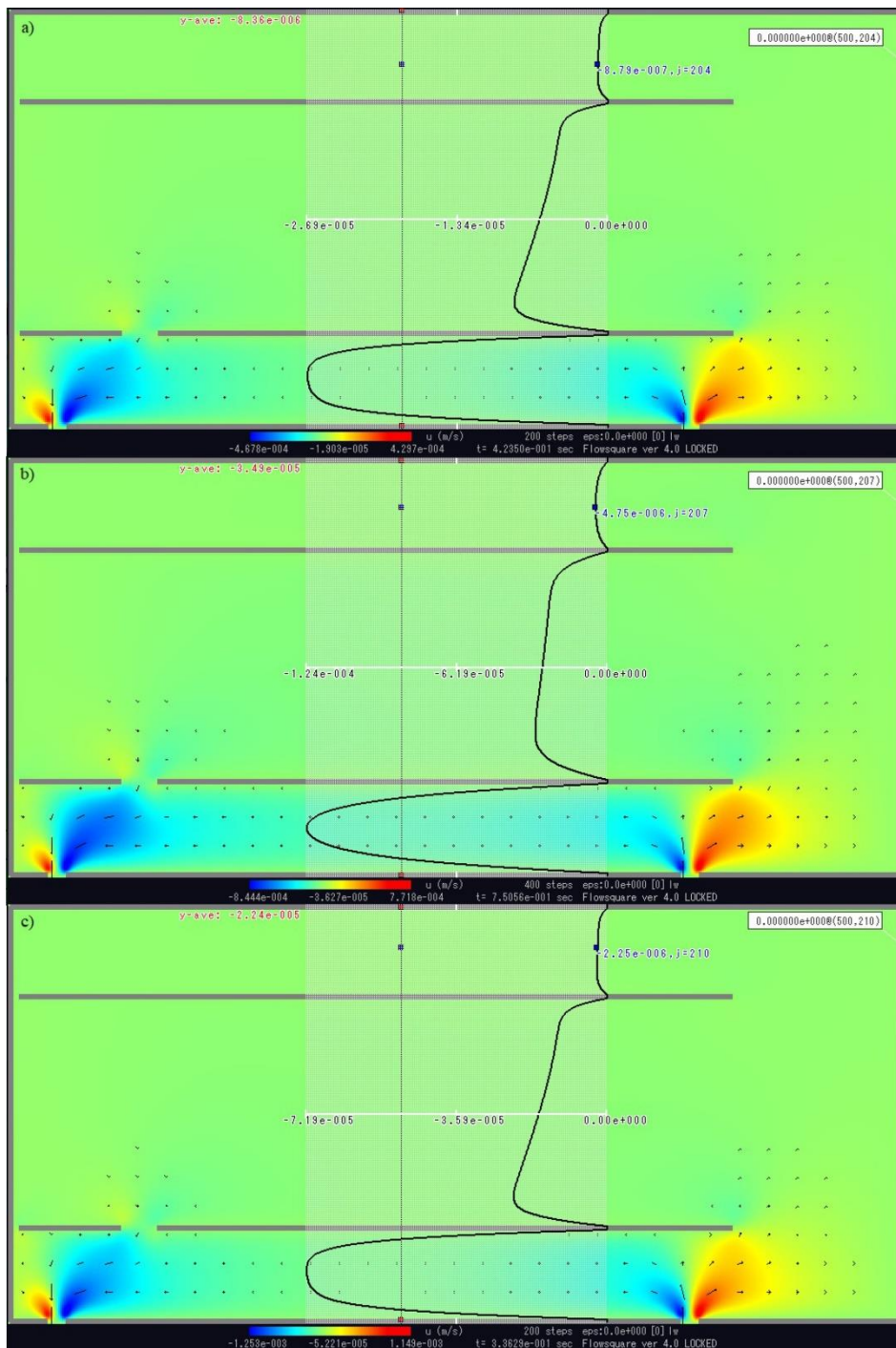

Slika 2.2.29 Brzina gasova kroz poprečni presek komore, koja je dobijena nakon 200 računskih koraka od početka simulacije za pritiske od a) 300 mTorr, b) 450 mTorr i c) 600 mTorr. Strelicama je označen ukupan smer kretanja dok je bojom označen intenzitet projekcije brzine u smeru s leva na desno.

Iako su za simulacije za sva tri pritiska unete iste vrednosti za vremenske i prostorne parametre proračuna, na slici 2.2.29 može se videti da je nakon 200 koraka u sva tri različita slučaja proteklo različito vreme. U programu je moguće odabrati da se kroz grafički prikaz rezultata pokazuju vrednosti jednog od nekoliko parametara. U našim proračunima je odabrana brzina u , odnosno horizontalna komponenta brzine čiji je pozitivan smer sa leva na desno. Takođe, strelicama je prikazana ukupna brzina gasa za određene oblasti prostora i to tako što strelica pokazuje smer kretanja dok njena dužina odgovara intenzitetu ukupne brzine. Na ovim slikama je prikazana i vrednost u

Asimetrično kapacitivno spregnuto pražnjenje velike zapremine

komponente brzine kroz poprečni presek. Pozicija ovog preseka je odabrana tako da se on nalazi između mesta na kojima gasovi ulaze i izlaze ali da ne bude u neposrednoj blizini ni jednog od njih. U trenutku simulacije koji je prikazan na slici 2.2.29 ni na jednom od tri pritiska nije još uvek uspostavljen stacionarni režim protoka. Ono što može da se primeti je da je brzina gasova značajno veća u oblasti između uzemljenih elektroda velikog i malog poluprečnika. S obzirom na to da su početni pritisci u svakoj tački prostora bili jednaki a da su brzine kojima gasovi u komoru ulaze i iz nje izlaze relativno male, tokom naših simulacija nije dolazilo ni do lokalnih promena u pritisku. Takođe, temperatura je bila ista u celoj unutrašnjosti reaktora.

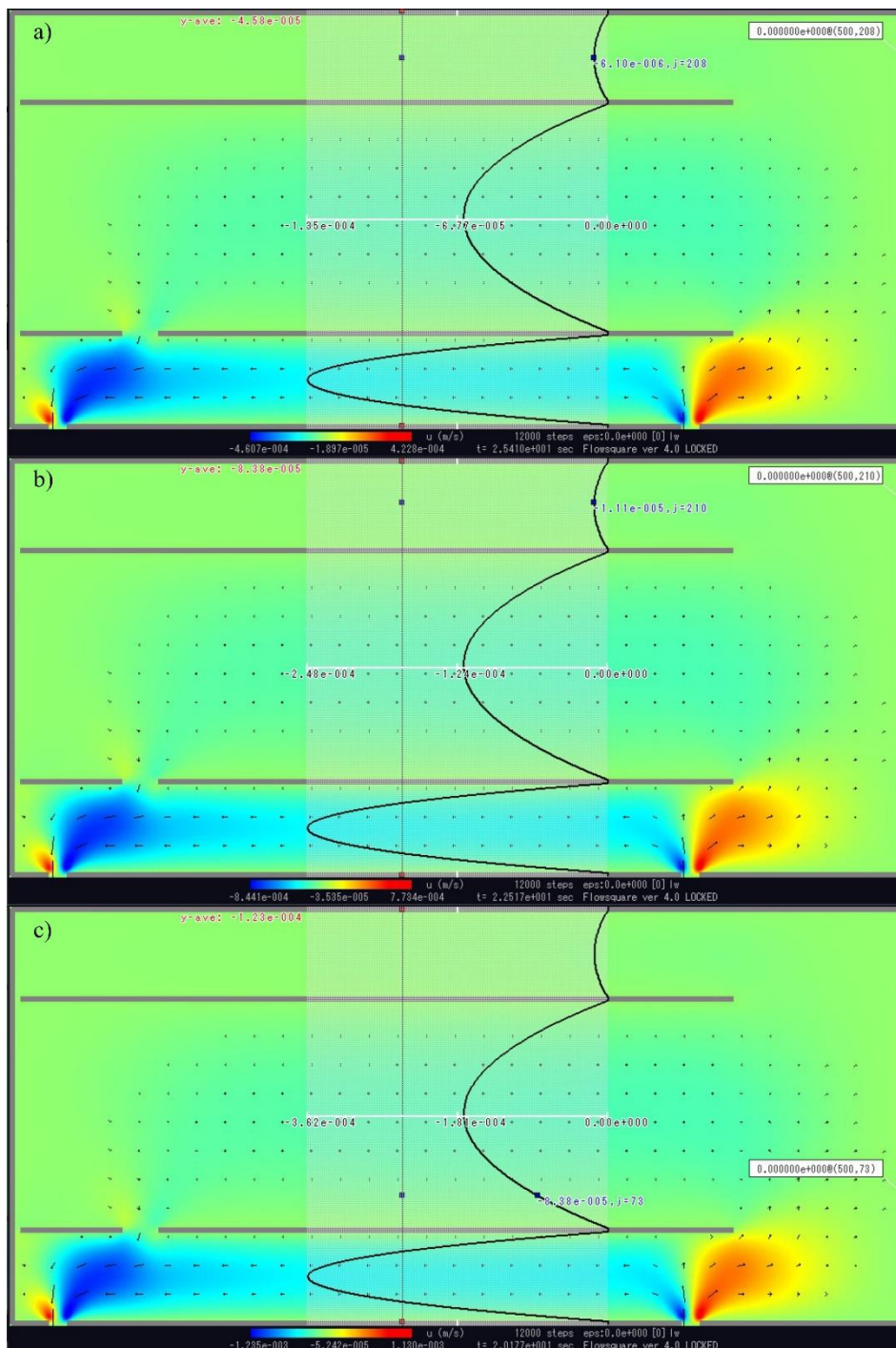

Slika 2.2.30 Brzina gasova kroz poprečni presek komore, koja je dobijena nakon 12000 računskih koraka od početka simulacije za pritiske od a) 300 mTorr, b) 450 mTorr i c) 600 mTorr. Strelicama

Asimetrično kapacitivno spregnuto pražnjenje velike zapremine

je označen ukupan smer kretanja dok je bojom označen intenzitet projekcije brzine u smeru s leva na desno.

Nakon kratkog vremena, na samom početku simulacije, vrlo brzo počinje da raste brzina gasa i u centralnom delu reaktora. Stacionarni režim se, za sva tri pritiska, postiže nakon okvirno 12000 koraka. U simulaciji će do tog trenutka da prođe između 20 s, za pritisak od 600 mTorr, i 25 s, za pritisak od 300 mTorr. Daljim tokom simulacije ne dolazi praktično ni do kakve promene ukupnih brzina ali ni njenih projekcija na jedan od dva karakteristična smera. Raspodela brzina na jednom poprečnom preseku posle uspostavljanja stacionarnog režima je prikazana na slici 2.2.30. Brzine će i dalje biti najveće u prostoru između dve uzemljene elektrode, odnosno tamo gde je najkraći put između mesta za dovod i odvod gasova. U centralnom delu komore će se gasovi kretati nešto sporije ali njihove brzine sada iznose oko polovine brzina koja se postižu u prostoru između elektroda.

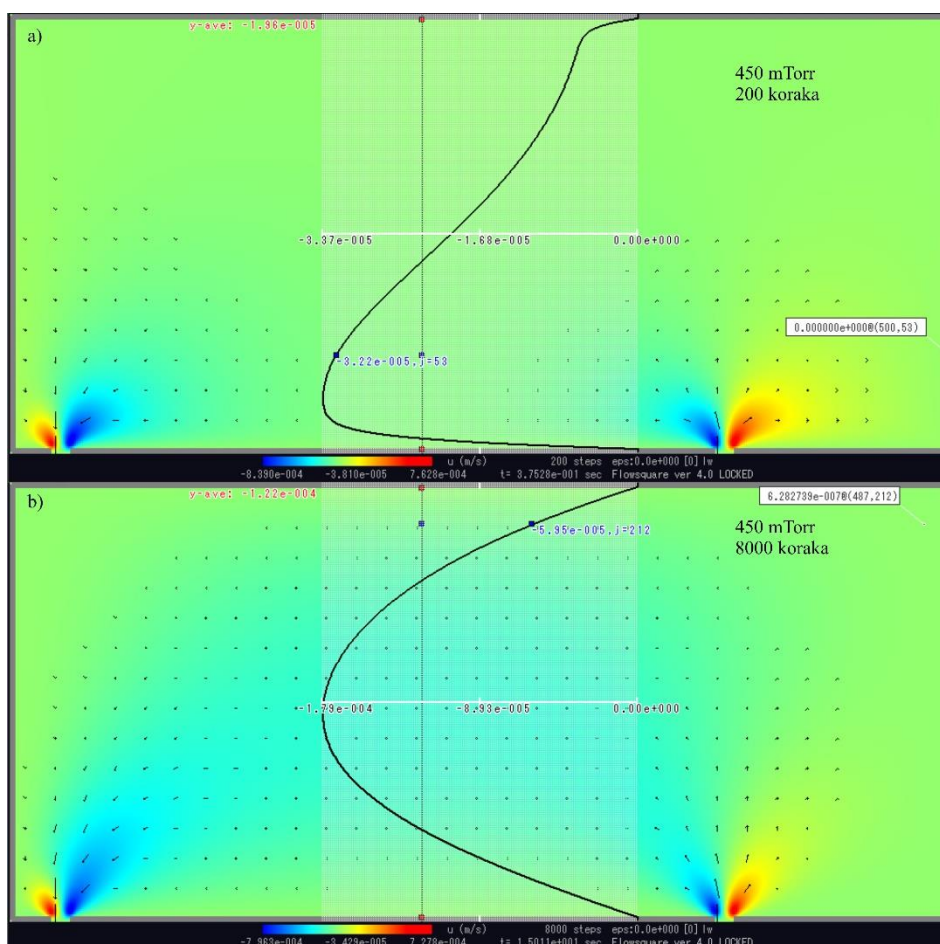

Slika 2.2.31 Brzine protoka gasova kada u komori nije bila postavljena dodatna uzemljena elektroda za pritisak od 450 mTorr nakon a) 200 i b) 8000 koraka simulacije.

S obzirom na to da su raspodele brzina praktično identične za sva tri pritiska za situaciju kada u komori nije bila postavljena dodatna uzemljena elektroda, na slici 2.2.31 smo prikazali brzine samo za pritisak od 450 mTorr nakon 200 koraka i nakon uspostavljanja stacionarnog režima, odnosno nakon 8000 koraka. U početnom periodu simulacije će najveći deo gasova da se kreće uz sam zid komore. Međutim, sa protokom vremena će rasti brzine u centralnom delu reaktora, tako da će nakon uspostavljanja stacionarnog režima gasovi da se kreću laminarno, kao kroz bilo koju cev. Zanimljivo

je da će ukupne brzine biti nešto niže, čak i u centralnom delu, nego kada je u komori bila postavljena dodatna uzemljena elektroda.

Vidimo da ubacivanjem dodatne elektrode ne dolazi do suštinskog poremećaja u protoku gasova. Odnosno, pokazano je da razlike koje nastaju tokom merenja u ove dve različite konfiguracije nisu uzrokovane manjkom gasa u centralnom delu komore, odnosno u prostoru oko napajane elektrode, već da će one biti posledica različitog rastojanja između napajane i uzemljene elektrode, promenjenog odnosa njihovih površina i, u slučaju masene spektrometrije, mesta na kome se vrši uzorkovanje čestica.

2.2.3 MASENA SPEKTROMETRIJA

U okviru ove glave će biti prikazani doprinosi atoma i molekula kiseonika u masenom spektru. Kiseonik je odabran zbog njegove važnosti u tretmanima tekstila. Kao što je rečeno u uvodu, tokom tretmana u plazmi se nagrizanjem stvaraju mikrostrukture koje utiču na hidrofилnost površine, odnosno povećavaju je. Međutim, ukoliko se tretman obavlja baš u kiseoničnoj plazmi, na površini uzorka će nastati i funkcionalne grupe koje sadrže ugljenik [100], [146]. U pitanju su grupe, kao što su $-OH$, $-C=O$, $-C-O-O-C-$, $-CHO$, $-COOH$, koje zbog svoje polarne prirode dodatno povećavaju hidrofилnost [100], [147], [148] i time omogućavaju lakšu i dugotrajniju adheziju materijala poput tekstilnih boja. Ovakve grupe se na polimerne površine obično ugrađuju u 3 koraka. Prvo će aktivne vrste u plazmi, bombardovanjem lanaca na površini, napraviti aktivne radikale [149]. Zatim dolazi do reakcije ovih radikala sa vrstama iz plazme i na kraju se funkcionalne grupe ugrađuju u polimerne lance, menjajući na taj način površinu uzorka. Jedan od načina na koji može doći do formiranja pomenutih grupa je, na primeru celuloze, prikazan na slici 2.2.32 [150].

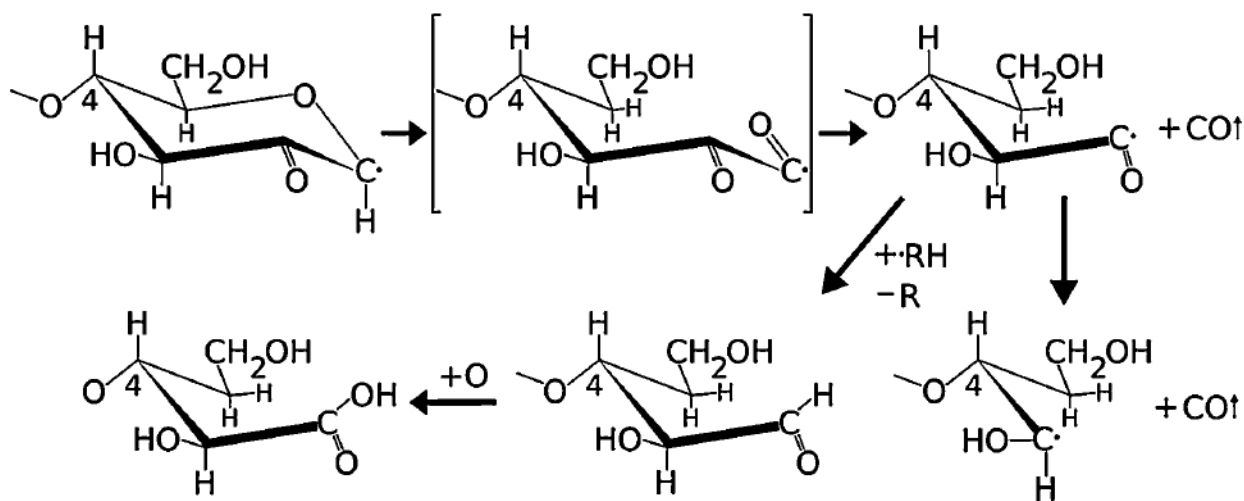

Slika 2.2.32 Proces oksidacije celuloze i formiranje aldehydnih i karboksilnih grupa [150].

Dodatno, pobuđene kiseonikove vrste su posmatrane kako zbog svoje uloge u samom pražnjenju tako i zbog toga što utiču na biohemijske procese u tretiranim semenima. Pre svega, od interesa su nam $O_2(^1\Delta_g)$ i $O_2(b^1\Sigma^+_g)$ stanja čije su energije 0,98 eV i 1,627 eV [151]. Njihova detekcija masenim spektrometrom postala je moguća još sredinom 50.-ih godina [152], a poznato je da u gasnoj kinetici učestvuju kao donori energije [153]. S obzirom da su u pitanju metastabilna stanja, ona ne

mogu da deekscituju direktno u osnovno stanje. Međutim, u binarnim sudarima između molekula koji se nalaze u ovim stanjima ($2O_2(^1\Delta_g)$ ili $2O_2(b^1\Sigma_g^+)$ ili $O_2(^1\Delta_g)+O_2(b^1\Sigma_g^+)$) može da dođe do neelastičnih sudara u kojima kao finalni proizvod nastaju molekuli u osnovnom stanju [153], [154], koji će razliku u energiji pretvoriti u kinetičku. Zavisno od toga koji se radni gas koristi u pražnjenju, na sličan način može doći do depopulacije ovih stanja i u sudarima sa molekulima (poput O_2 , NO_2 , NO , $H_2\dots$) ili atomima (Ar) u nepobuđenom stanju [155]. Zanimljivo je da, zavisno od pritiska i koncentracije molekula u metastabilnim stanjima, njihovo prisustvo može da utiče i na elektronegativnost plazme odnosno da, na malim pritiscima, disocijativni zahvat tipa:



može da bude jedan od glavnih kanala za nastajanje O^- jona [156]. Do njihove deekscitacije može da dođe i na zidovima reaktora [155], [157]. Na ovaj način, prilikom tretmana bioloških uzoraka, molekuli iz plazme umesto zidu komore, svoju energiju mogu predaju tretiranom semenu. Ovo je veoma važan korak u tretmanima biljaka jer molekul kiseonika u singletnom delta stanju predstavlja signalni molekul. U biljkama uglavnom nastaje tokom procesa fotosinteze i to kada na list pada prevelika količina svetlosti pa višak energije molekul hlorofila predaje kiseoniku u osnovnom stanju [158]. Iako prevelika koncentracija ovog molekula može da pokrene signalne puteve koji će da izazovu nekrozu lista ili kompletne biljke [159], [160] $O_2(^1\Delta_g)$ ima i druge funkcije. Vrlo je toksičan za viruse i bakterije [161] pa se ponekad stvara i kao odgovor organizma kada postoji napad ovih patogenih. Može da pomogne biljci u procesu aklimacije na nove uslove [160], a u malim količinama pomaže i u regulaciji oksidativnog stesa [162]. Reaguje sa velikim brojem biomolekula uključujući masti, proteine i DNK [160] i učestvuje u aktivaciji određenih gena [163], [164]. U našim eksperimentima će biti ispitani doprinosi atomskog i molekulskog kiseonika na tri pritiska i u opsegu snaga od 0 do 700 W sa dve različite dimenzije uzemljene elektrode.

Merenja masenih spektara će biti rađena na dve energije jonizujućih elektrona odnosno na 70 eV i na 20 eV. Energija od 70 eV se koristi kao standardna energija na kojoj se vrše snimanja masenih spektara. Najvećem broju vrsta maksimumi preseka za jonizaciju se nalaze upravo na toj energiji, odnosno na toj energiji je jonizacija najefikasnija [19]. Druga energija jonizujućih elektrona je izabrana pošto se nalazi ispod praga za disocijativnu jonizaciju kiseonika, koji se nalazi na 23 eV [129](jednačina 2.11). U tom slučaju su svi atomi kiseonika, detektovani od strane masenog spektrometra potekli iz pražnjenja a ne unutar jonizacione komore masenog spektrometra.

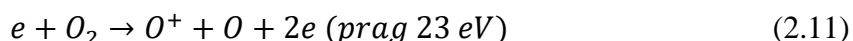

Snimanje masenih spektara je bilo bitno i zbog praćenja prisustva (doprinos) argonovih atoma. Priprema sistema za masenu spektrometriju, protoka i smeše gasova je maksimalno smanjila uticaj nepoželjnih primesa, ali je bilo potrebno pratiti da li dolazi do promena tokom procesa merenja i koliko su te fluktuacije značajne.

2.2.3.1 Uzemljena elektroda većeg poluprečnika

Na slici 2.2.28 se nalazi kompletan maseni spektar koji je snimljen na nominalnoj snazi pražnjenja od 500 W i na pritisku od 450 mTorr, dok je energija jonizujućih elektrona bila podešena na 70 eV. Rezultati su na slici 2.2.33 a) predstavljeni preko odbroja a na slici 2.2.33 b) preko doprinosa koje određeni odnos m/Z ima u ukupnom spektru (u procentima). S obzirom na to da je u pitanju energija jonizujućih elektrona koja je dovoljna da se izvrši disocijativna jonizacija mnogih molekula ali i da su na toj energiji najveće verovatnoće za procese jonizacije, u ovom spektru se nalazi nekoliko molekulskih vrsta a totalni odbroji su veliki. Molekulski kiseonik je dominantna vrsta, sa ukupnim doprinosom od oko 78 % ali su u značajnoj meri prisutne i vrste koje nastaju kao posledica cepanja većih molekula poput N (14 amu), O (16 amu), OH (17 amu) i H (1 amu). Iako je

Asimetrično kapacitivno spregnuto pražnjenje velike zapremine

izvršena procedura pripreme sistema za merenje, zbog toga što se vakuumiranje vrši samo mehaničkom pumpom, određene primese, poput vode i azota, su i dalje prisutne. Doprinos argona, koji je u smešu ubačen kako bi mogla da se vrše aktinometrijska merenja, iznosi oko 1 %.

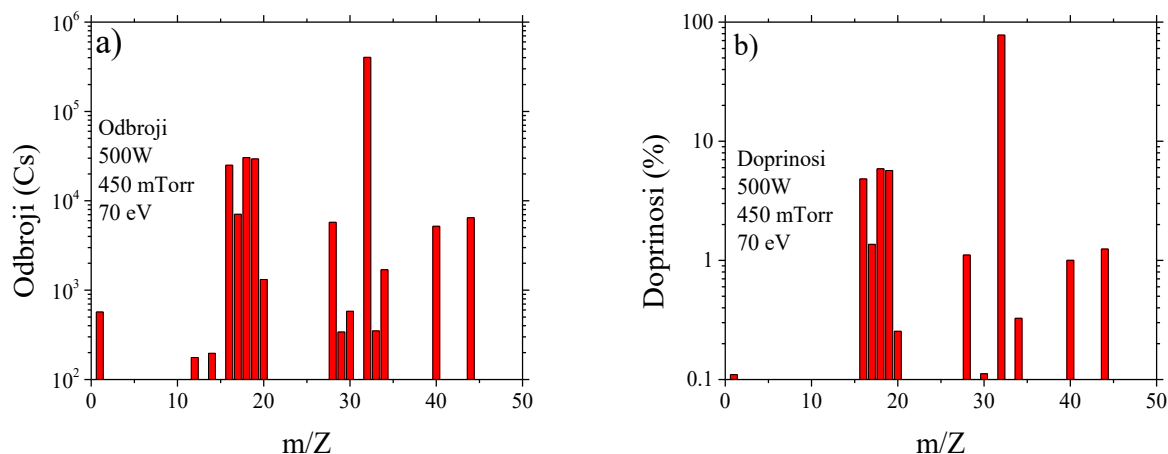

Slika 2.2.33 Maseni spektar neutralnih čestica snimljen na pritisku od 450 mTorr, na snazi od 500 W sa energijom jonizujućih elektrona od 70 eV prikazan preko a) ukupnih odbroja i b) relativnog doprinosa.

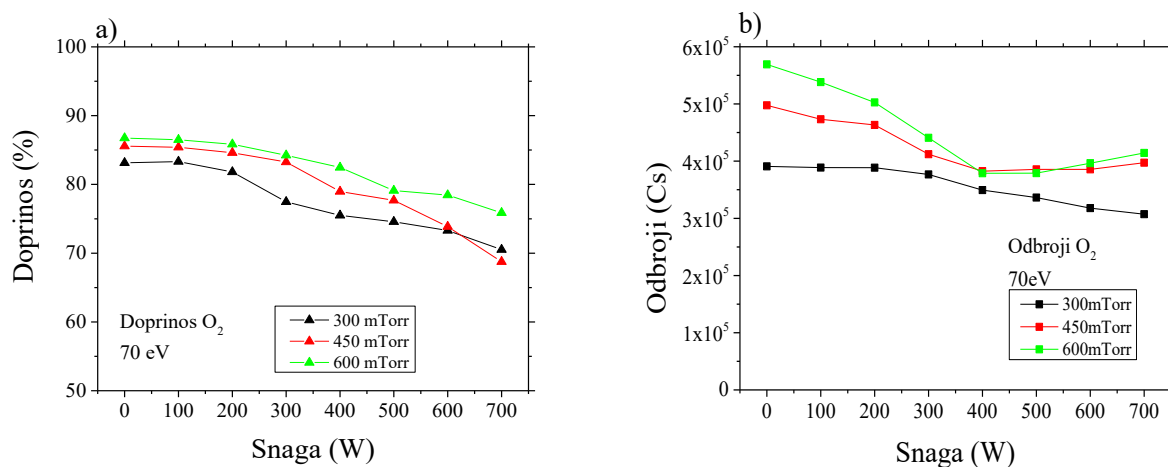

2.2.34 Doprinosi molekuskog kiseonika u zavisnosti od pritiska i primenjene snage, snimljeni na energiji jonizujućih elektrona od 70 eV predstavljeni preko a) procenta udela u ukupnom spektru i b) totalnih odbroja, uzemljena elektroda velikog poluprečnika.

Zavisnost doprinosa molekuskog kiseonika od primenjene snage, koji je izmeren sa energijom jonizujućih elektrona od 70 eV, je prikazan na slici 2.2.34. Merenja su rađena na tri različita pritiska a rezultati su prikazani preko doprinosa na slici 2.2.34 a), a preko totalnih odbroja na slici 2.2.34 b). Kao što je i očekivano, doprinosi molekula opadaju sa povećanjem primenjene snage. S druge strane njihovi totalni odbroji na različitim pritiscima različito zavise od snage pražnjenja. Na najmanjem pritisku su odbroji praktično konstantni sve do snage od 300 W, posle čega počinju da opadaju. Na pritiscima od 450 mTorr i 600 mTorr do velikog pada dolazi na malim snagama posle čega odbroji ostaju konstantni ili polako rastu. Razlika u ponašanju doprinosa u procentima i ukupne količine molekula koji su izbrojani može da se objasni jedino time da na malim snagama odbroji

Asimetrično kapacitivno spregnuto pražnjenje velike zapremine

molekula opadaju nešto sporije nego odbroji drugih vrsta dok na velikim snagama, gde dolazi do rasta, oni rastu sporije nego ostale vrste. Na velikim snagama može da se očekuje i porast broja produkata disocijacije primesa kao što su recimo N ili OH ali i O atoma.

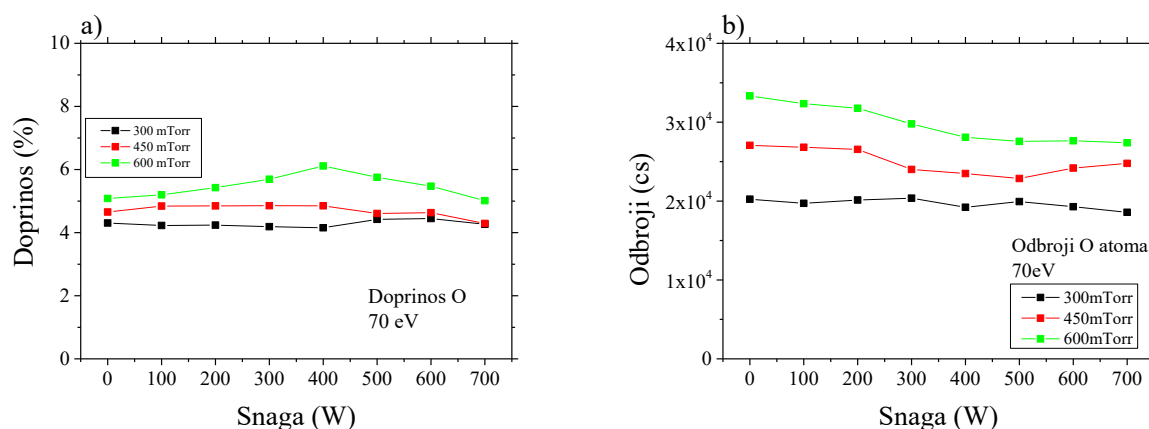

Slika 2.2.35 Doprinosi atomskog kiseonika u zavisnosti od pritiska i primenjene snage, snimljeni na energiji jonizujućih elektrona od 70 eV predstavljeni preko a) procenta udela u ukupnom spektru i b) totalnih odbroja, uzemljena elektroda velikog poluprečnika.

Udeo atomskog kiseonika u ukupnom masenom spektru, kao i njegova zavisnost od snage i pritiska, je prikazana na slici 2.2.35 a) dok je na slici 2.2.35 b) prikazano kako od istih parametara zavise njegovi totalni odbroji. Treba imati u vidu da na ovoj energiji jonizujućih elektrona veliki broj O atoma zapravo nastaje u jonizacionoj komori maseno-energijskog analizatora a ne u samoj komori za pražnjenje. Prilikom sudara elektrona visoke energije sa molekulom kiseonika, u procesu disocijativne jonizacije, nastaje O⁺ jon. S obzirom na to da prag za ovu reakciju iznosi 23 eV, sa energijom elektrona od 70 eV on je nadmašen nekoliko puta. Kao i kod molekula, veći odbroji ali i doprinosi su zabeležni na višim pritiscima. Na manjim pritiscima totalni odbroji slabo zavise od primenjene snage dok se na 600 mTorr primećuje određen pad. Maksimum doprinosa O atoma je zabeležen na pritisku 600 mTorr i snazi od 400 W, što su uslovi na kojima je zabeležen i najveći pad O₂ molekula.

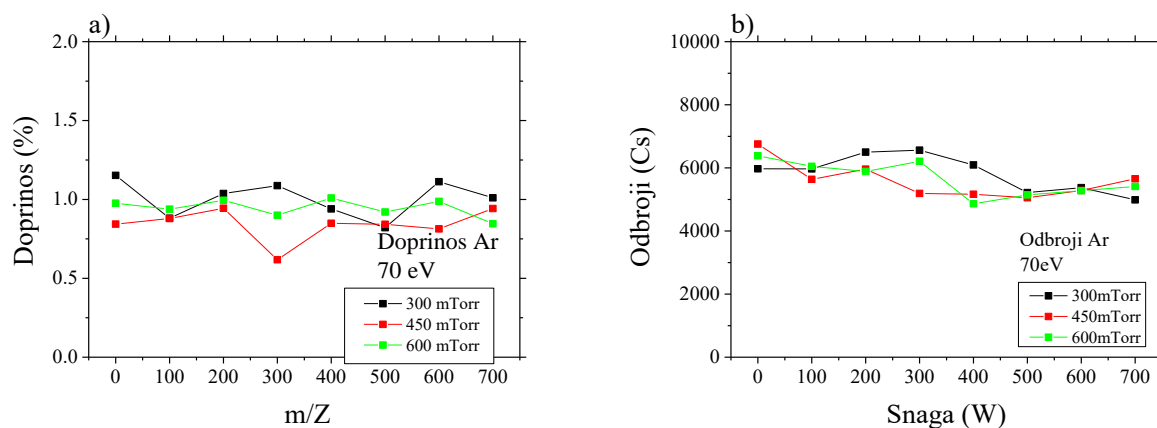

Slika 2.2.36 Doprinosi argona u zavisnosti od pritiska i primenjene snage, snimljeni na energiji jonizujućih elektrona od 70 eV predstavljeni preko a) procenta udela u ukupnom spektru i b) totalnih odbroja, uzemljena elektroda velikog poluprečnika.

Smeša, 99 % O₂ + 1 % Ar, koja je korišćena tokom svih merenja u asimetričnom reaktoru velike zapremine je kontrolisana protokomerima. Na slici 2.2.36 a) se vidi da, uz male fluktuacije, doprinos argona u ukupnoj smeši praktično ne zavisi ni od pritiska ni od primenjene snage. Totalni odbroji argona imaju nešto komplikovaniju zavisnost od snage a njihov maksimum je, tokom pražnjenja, zabeležen na pritisku od 300 mTorr

Jedan primer kompletnog masenog spektra neutralnih čestica koji je snimljen na snazi pražnjenja od 500 W i pritisku od 450 mTorr sa energijom jonizujućih elektrona od 20 eV je prikazan na slici 2.2.37. Sa leve strane slike (2.2.37a)) je prikazano kako ukupni odbroji zavise od mase čestica dok je sa desne (2.2.37 b)) prikazan isti spektar ali preko doprinosa koje određeni odnos m/Z ima u ukupnom spektru. Iako je i u ovom slučaju ispoštovana procedura pripreme za merenje, može da se primeti izvestan doprinos primesa poput vode, azota i ugljen dioksida. Kao što je i očekivano, najviše izbrojanih čestica pripada molekularnom kiseoniku dok se na drugom mestu nalazi voda. Argon, čiji je protok kontrolisan da iznosi 1 % protoka kiseonika se po relativnoj zastupljenosti nalazi na četvrtom mestu. Na masi, odnosno m/Z, od 44 su dobijeni odbroji koji su vrlo slični odbroju argona. Na toj masi mogu da se nađu, jednom jonizovane, dve molekulske vrste: CO₂ i N₂O.

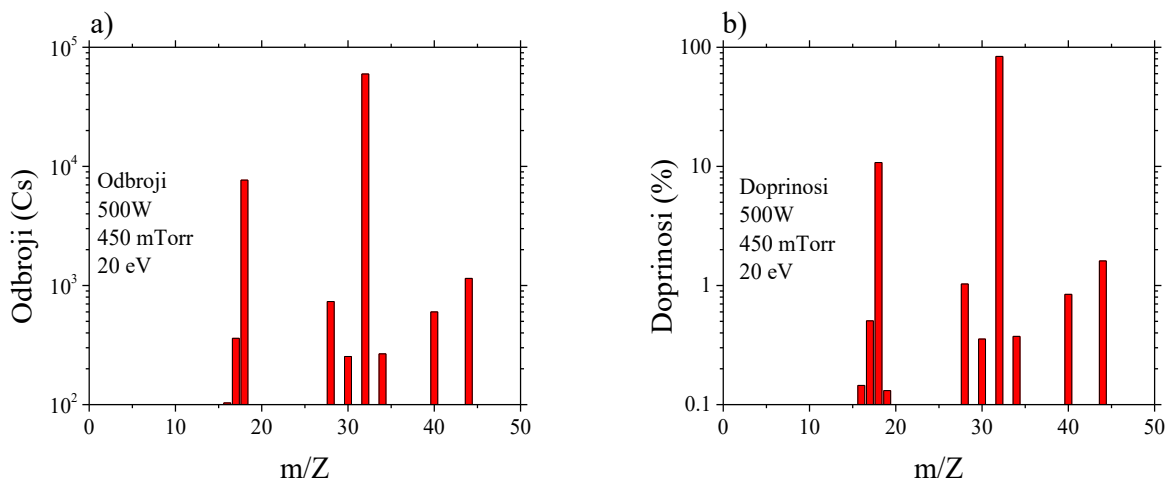

Slika 2.2.37 Maseni spektar neutralnih čestica snimljen na pritisku od 450 mTorr, na snazi od 500 W sa energijom jonizujućih elektrona od 20 eV prikazan preko a) ukupnih odbroja i b) relativnog doprinosa.

Doprinosi molekuskog kiseonika snimljeni su sa energijom jonizujućih elektrona od 20 eV i na slici 2.2.38 a) može se videti kako zavise od primenjene snage i pritiska. Odbroji, koji su dobijeni pri istim uslovima merenja i pražnjenja, su prikazani na slici 2.2.38 b). S obzirom da je ova energija elektrona ispod praga za disocijativnu jonizaciju i značajno ispod maksimalnog preseka kako za jonizaciju tako i za disocijaciju, može da se kaže da su doprinosi koji su izmereni na ovaj način nešto realniji odraz stanja u samom pražnjenju. Ono što je karakteristično je postojanje platoa, na manjim snagama, na kojima promena snage pražnjenja ne dovodi ni do kakvih promena u doprinosima O₂. Kao što smo primetili i prilikom merenja derivativnim sondama, kada u komori nije postavljena dodatna uzemljena elektroda, aktivni deo plazme zauzima samo prostor u neposrednoj blizini napajane elektrode. Povećanjem primenjene snage dolazi i do povećanja aktivnog dela plazme, što može da se primeti i vizuelnim osmatranjem. Kada je pražnjenje skoncentrisano uz samo napajanu elektrodu, disosovane ili pobuđene vrste kiseonika teško dolaze do masenog spektrometra, a energija jonizujućih elektrona od 20 eV nije dovoljna da se izvrši disocijativna jonizacija. Snaga na kojoj se efektivna zapremina plazme poveća dovoljno da ona dosegne otvor masenog spektrometra zavisi od

pritiska. Nakon ove granične vrednosti dolazi do opadanja prinosa molekuskog kiseonika, kako zbog povećane disocijacije na samom mestu na kome se nalazi otvor za uzorkovanje tako i zbog činjenice da će u maseni spektrometar sve više dospovati i molekuli koji se ne nalaze u osnovnom stanju i koji mogu da se disosuju i na energiji od 20 eV. Kao što je očekivano, ova granična snaga će biti najmanja na pritisku od 200 mTorr na kome opadanje prinosa molekuskog kiseonika počinje da se primećuje već na 200 W. Na pritiscima od 450 i 600 mTorr se ovo događa na snagama koje su, respektivno, veće od 300 W i 400 W.

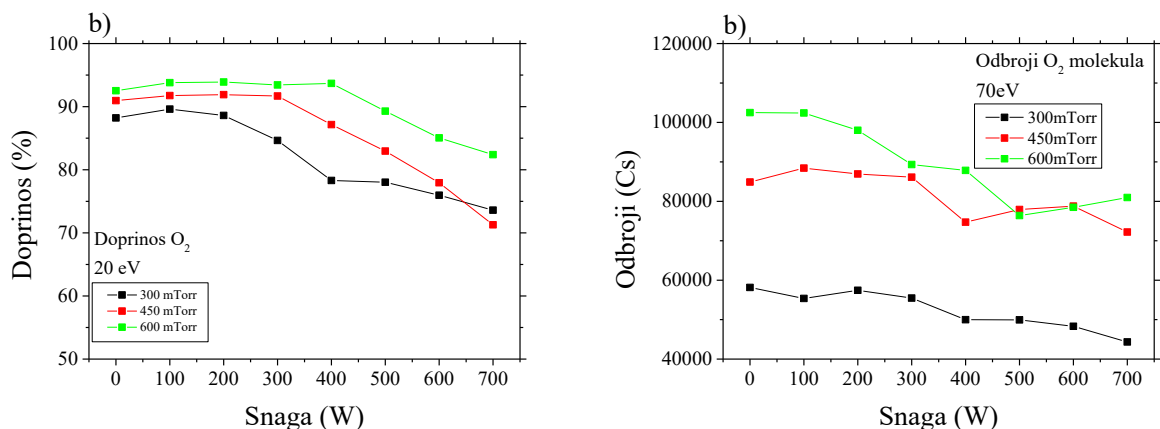

Slika 2.2.38 Doprinosi molekuskog kiseonika u zavisnosti od pritiska i primenjene snage, snimljeni na energiji jonizujućih elektrona od 70 eV predstavljeni preko a) procenta udela u ukupnom spektru i b) totalnih odbrojaja, uzemljena elektroda velikog poluprečnika.

Doprinosi atomskog kiseonika, koji su izmereni pri energiji jonizujućih elektrona od 20 eV, su prikazani na slici 2.2.39 a). Oni su sada značajno niži i nalaze se između 0,05 i 0,35 %. Veći doprinosi su, zbog lakšeg prenosa energije iz električnog polja na elektrone i sa elektrona na neutrane, izmereni na nižem pritisku. Povećanje snage pražnjenja, zbog veće verovatnoće da dođe do procesa jonizacije ili disocijacije dovodi do porasta doprinosa O-atoma. Njihovi totalni odbrojaji su prikazani na slici 2.2.39 b). Zbog toga što su ukupne vrednosti male, greška merenja je nešto veća pa na određenim uslovima dolazi do „odskakanja“ rezultata. Ipak, trend porasta sa povećanjem snage je jasno vidljiv.

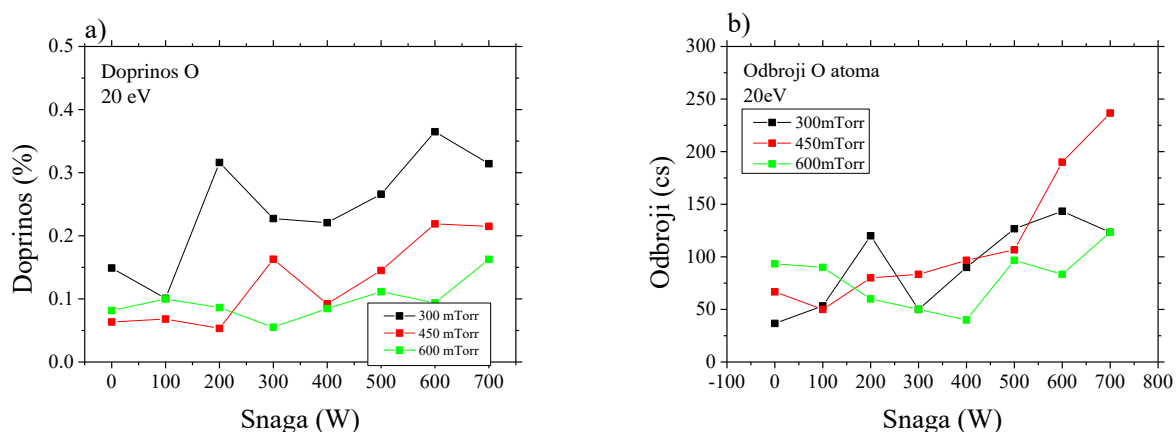

Slika 2.2.39 Doprinosi atomskog kiseonika u zavisnosti od pritiska i primenjene snage, snimljeni na energiji jonizujućih elektrona od 20 eV predstavljeni preko a) procenta udela u ukupnom spektru i b) totalnih odbrojaja, uzemljena elektroda velikog poluprečnika.

I u ovim mernim uslovima, sa energijom jonizujućih elektrona od 20 eV, doprinosi argona su za sve pritiske i snage pražnjenja oscilovali oko vrednosti od 1 %.

2.2.3.2 Uzemljena elektroda manjeg poluprečnika

Primer masenog spektra koji je snimljen na pritisku od 450 mTorr sa nominalnom snagom pražnjenja od 500 W i energijom jonizujućih elektrona od 70 eV je, za slučaj kada je u komori bila postavljena dodatna uzemljena elektroda, prikazan na slikama 2.2.40 a) (preko odbroja) i 2.2.40 b) (preko doprinosa). U poređenju sa merenjima bez dodatne elektrode, u ovim spektrima se nalazi nešto manje vrsta a odbroji na pojedinačnim masama, odnosno odnosima m/Z , su za oko jedan red veličine manji. Postoje dva razloga zbog kojih u spektrima koji su mereni u ovoj geometriji uzemljene elektrode postoji manje primesa. Oni molekuli koji se zadržavaju na zidovima komore i koji polako desorbuju u njenu unutrašnjost, poput vode, će se pre svega naći u prostoru između dve uzemljene elektrode i biće dejstvom mehaničke pumpe, u najvećoj meri, izvučeni iz komore pre nego što dođu u oblast iz koje bi mogli da budu prikupljeni masenim spektrometrom. Dodatno, prilikom postavljanja uzemljene elektrode manjeg poluprečnika su zamenjene praktično sve gumice koje su odgovorne za održavanje vakuuma, dok su one koje nisu mogle da se zamene bile očišćene i ponovo postavljene. S obzirom na to da se komora između merenja ne otvara, ovim promenama u sistemu treba da se postigne manje ucurivanje gasova, pre svega azota i ugljen dioksida. Dominantna vrsta u ovom spektru je, takođe, molekulski kiseonik. Treba primetiti da njegov doprinos sada iznosi 84 % dok je pre postavljana dodatne uzemljene elektrode on iznosio 78 %.

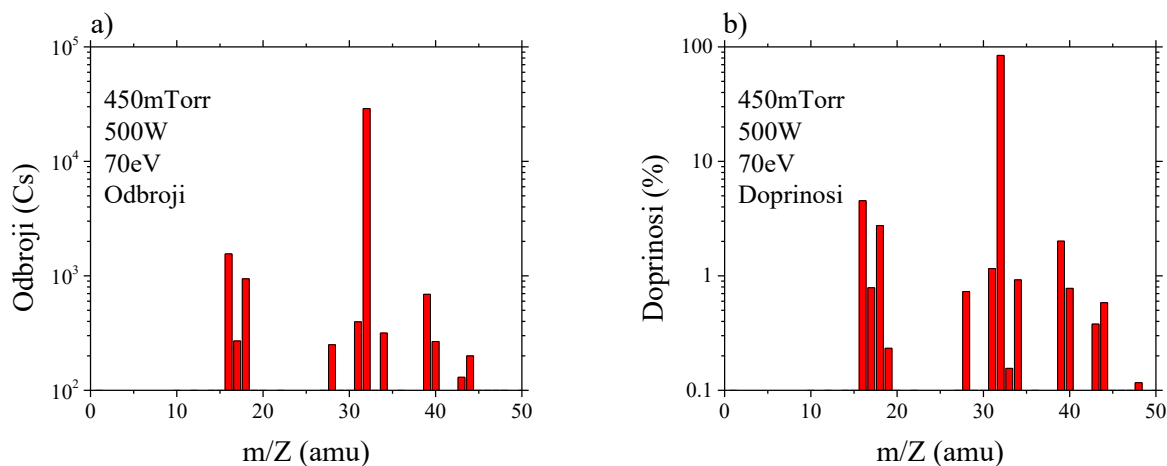

Slika 2.2.40 Maseni spektar neutralnih čestica snimljen na pritisku od 450 mTorr, na snazi od 500 W sa energijom jonizujućih elektrona od 70 eV prikazan preko a) ukupnih odbroja i b) relativnog doprinosa.

Doprinos molekulskog kiseonika u ukupnom masenom spektru koji je snimljen sa energijom jonizujućih elektrona od 70 eV je prikazan na slici 2.2.41 a). Dobijene vrednosti su za sve pritiske i snage nešto niže nego tokom merenja bez dodatne elektrode. Međutim, postoji velika razlika u zavisnosti ovih doprinosa od primenjene snage. Naime, povećanje snage će da dovede do izvesnog pada ali će on biti znatno manji nego kada dodatna elektroda nije bila korišćena. Za razliku od prethodno opisane konfiguracije kada je u datom opsegu snaga udeo molekula kiseonika u ukupnom

Asimetrično kapacitivno spregnuto pražnjenje velike zapremine

spektru čestica mogao da opadne i za celih 20 %, u ovakvoj konfiguraciji njegova promena, ni na jednom pritisku, nije veća od 5 %. Totalni odbroji O₂ molekula su prikazani na slici 2.2.41 b). Kao i u konfiguraciji sa velikom uzemljenom elektrodom, odbroji opadaju sa primenjenom snagom a rastu, kao i doprinosi, sa povećanjem pritiska na kome se merenje vrši.

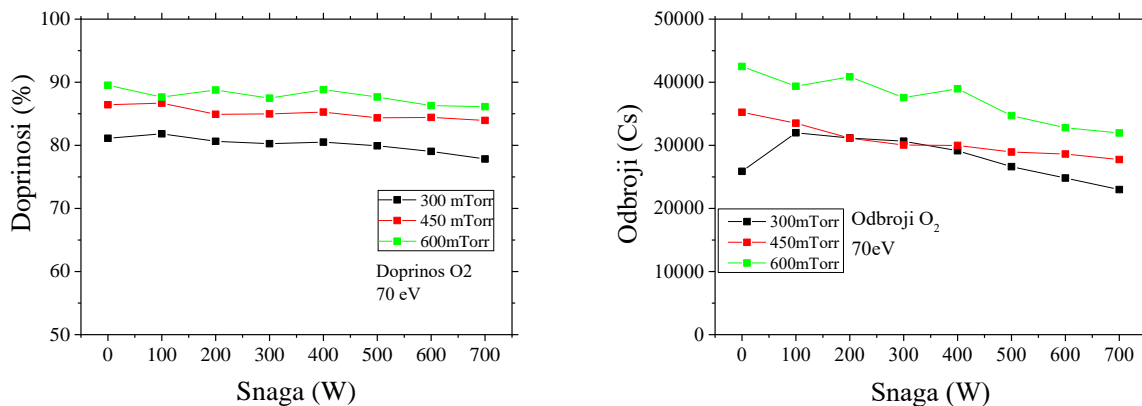

Slika 2.2.41 Doprinosi molekuskog kiseonika u zavisnosti od pritiska i primenjene snage, snimljeni na energiji jonizujućih elektrona od 70 eV predstavljeni preko a) procenta udela u ukupnom spektru i b) totalnih odbroja, uzemljena elektroda malog poluprečnika.

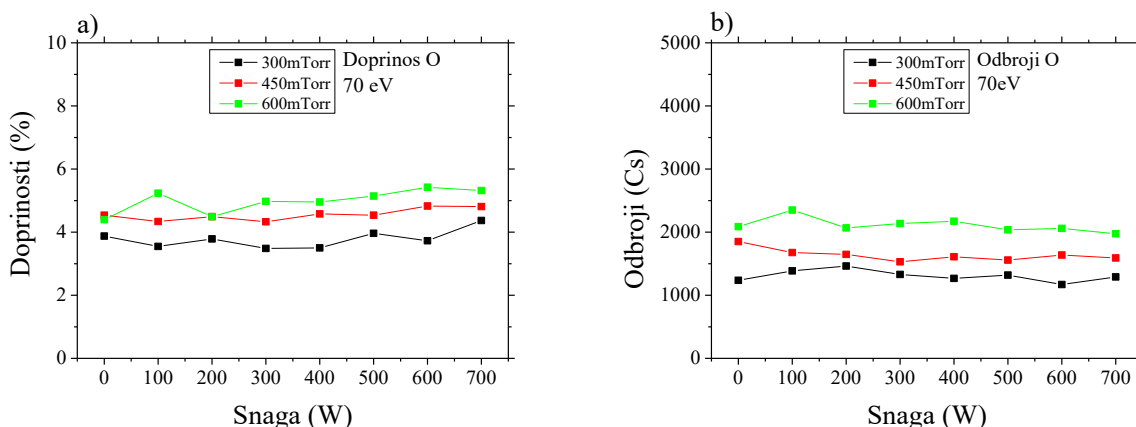

Slika 2.2.42 Doprinosi atomskog kiseonika u zavisnosti od pritiska i primenjene snage, snimljeni na energiji jonizujućih elektrona od 70 eV predstavljeni preko a) procenta udela u ukupnom spektru i b) totalnih odbroja, uzemljena elektroda malog poluprečnika.

Na slici 2.2.42 a) je prikazano kako, sa dodatnom uzemljenom elektrodom, doprinosi atomskog kiseonika zavise od primenjene snage za tri različita pritiska, kada je energija jonizujućih elektrona bila podešena na 70 eV. Kao i u slučaju bez dodatne elektrode, doprinosi O atoma slabo zavise od primenjene snage iako može da se primeti trend blagog rasta. Kreću se između 3,5 i 5,5 %, što su takođe vrednosti koje su vrlo slične onima koje su dobijene u drugačijoj konfiguraciji uzemljene elektrode. Totalni odbroji, prikazani na slici 2.2.42 b), praktično uopšte ne zavise od primenjene snage dok su veći odbroji izmereni na većim pritiscima.

Asimetrično kapacitivno spregnuto pražnjenje velike zapremine

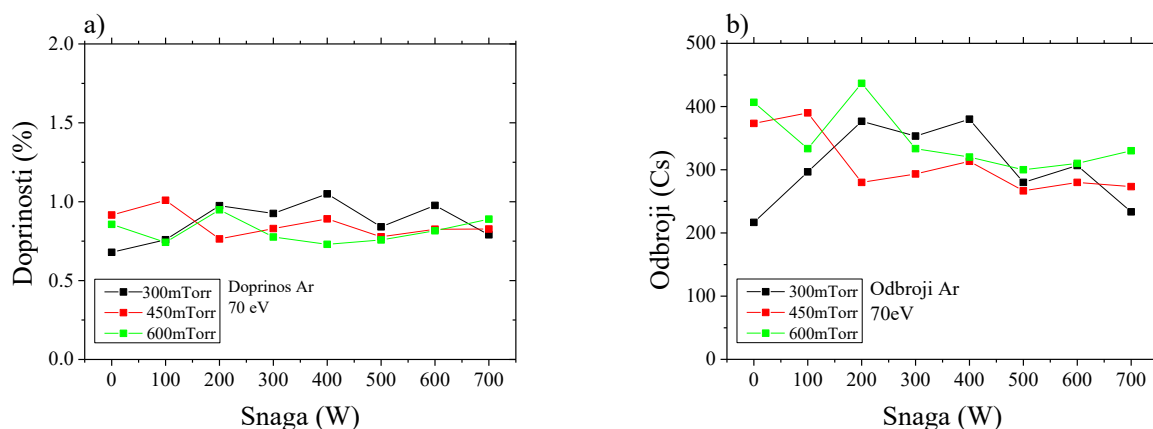

Slika 2.2.43 Doprinosi argona u zavisnosti od pritiska i primenjene snage, snimljeni na energiji jonizujućih elektrona od 70 eV predstavljeni preko a) procenta udela u ukupnom spektru i b) totalnih odbroja, uzemljena elektroda malog poluprečnika.

Doprinosi argona se i u konfiguraciji sa dodatnom uzemljenom elektrodom, prilikom merenja sa energijom elektrona od 70 eV kreću oko 1 % a prikazani su na slici 2.2.43 a). Ukupni odbroji, prikazani na slici 2.2.43 b), su relativno mali i vrlo nepravilno zavise kako od snage tako i od pritiska.

Jedan primer masenog spektra za slučaj kada je u komori bila postavljena uzemljena elektroda manjeg poluprečnika je prikazan na slici 2.2.44, preko odbroja (2.2.44 a)) i preko doprinosa (2.2.44 b)). Snimljen je na pritisku od 450 mTorr i snazi od 500 W dok je energija jonizujućih elektrona bila fiksirana na 20 eV. Najdominantnija vrsta, kao i kada su merenja rađena sa elektrodom većeg poluprečnika, je molekularni kiseonik čiji doprinos iznosi skoro 95 % od svih detektovanih čestica. Sledeća vrsta po broju odbroja je voda sa oko 6 % udela u ukupnom spektru. Treća vrsta po zastupljenosti ima m/Z odnos od 31 i doprinos od nešto više od dva procenta. Sa oko 1 % udela u ukupnom spektru se nalaze još i vrste na masama od 28 (N_2), 34 (H_2O_2), 40 (Ar) i 44 (CO_2 i N_2O). Sve ostale vrste imaju doprinose koji su značajno ispod 1 %. U poređenju sa graficima na slici 2.2.37, na kojima su prikazana merenja u istim uslovima, ali u slučaju kada je korišćena uzemljena elektroda većeg poluprečnika, može da se primeti da su odbroji nešto niži ali i da je udeo kiseonika znatno veći, odnosno da je udeo ostalih vrsta u spektru niži. Jedan od razloga za ovakve razlike u rezultatima treba potražiti i u relativnom položaju otvora za uzorkovanje u odnosu na napajanje i uzemljenu elektrodu. Naime, tokom merenja sa uzemljenom elektrodom velikog poluprečnika, zavisno od primenjene snage i pritiska, otvor za uzorkovanje može da se nađe u aktivnom delu plazme. S obzirom na to da je telo masenog spektrometra uzemljeno, u tim uslovima se oko njega formira prielektrodna oblast u kojoj je električno polje veliko. To znači da će u jednom delu zapremine, ispred otvora za uzorkovanje, postojati oblast iz koje se joni usmeravaju prema njemu. Dodatno, kao što je rečeno u uvodu, zbog postojanja prielektrodne oblasti u kojoj elektroni dobijaju energiju pomeranjem njene granice, u toj oblasti će dolaziti i do predaje energije neutralnim česticama. To praktično znači da ispred samog otvora za uzorkovanje sada postoji „izvor“ pobuđenih čestica i jona, što se tokom merenja vidi kao spektar sa većim brojem vrsta i višim odbrojima. S druge strane kada je bila postavljena dodatna uzemljena elektroda, tako da se otvor za prikupljanje čestica nalazi praktično na njenoj površini, prielektrodna oblast se formira na celoj uzemljenoj elektrodi i biće znatno uniformnija. Električno polje će u tim uslovima biti manje, pa će u oblasti ispred masenog spektrometra elektroni gasu predavati znatno manje energije. To dalje znači da će se u prostoru ispred otvora za uzorkovanje nalaziti i neutrali sa manje energije, koje je tokom merenja teže jonizovati, što kao posledicu daje spektre sa manjim odbrojima, pogotovo za vrste koje nastaju kao proizvodi disocijacije.

Asimetrično kapacitivno spregnuto pražnjenje velike zapremine

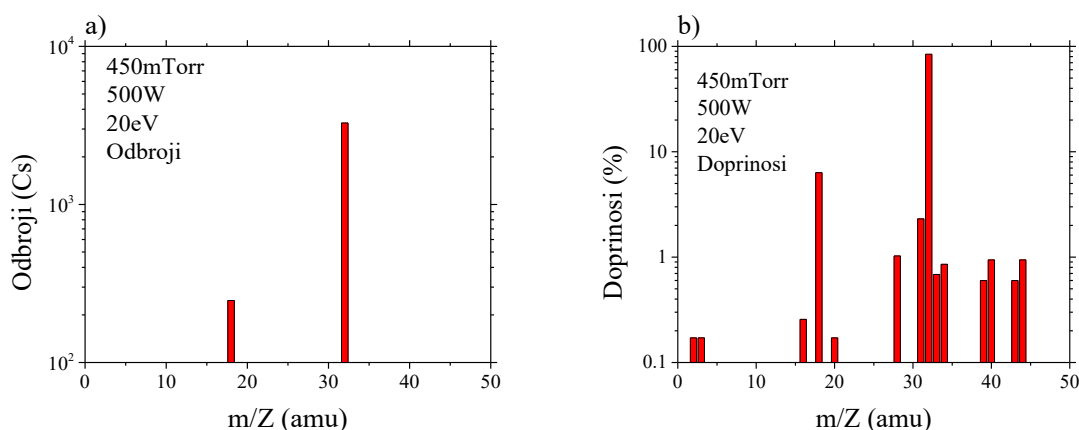

Slika 2.2.44 Maseni spektar neutralnih čestica snimljen na pritisku od 450 mTorr, na snazi od 500 W sa energijom jonizujućih elektrona od 20 eV prikazan preko a) ukupnih odbroja i b) relativnog doprinosa, uzemljena elektroda malog poluprečnika.

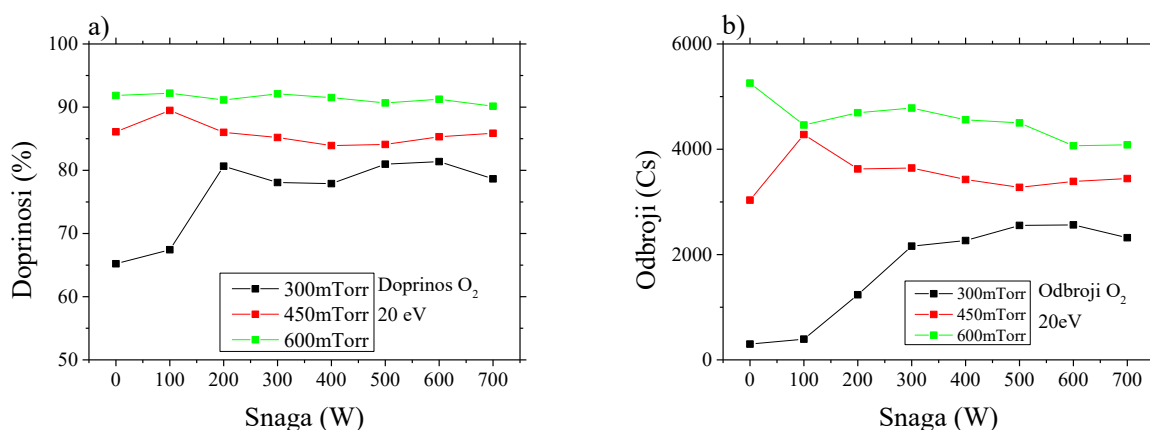

Slika 2.2.45 Doprinosi molekuskog kiseonika u zavisnosti od pritiska i primenjene snage, snimljeni na energiji jonizujućih elektrona od 20 eV predstavljeni preko a) procenta udela u ukupnom spektru i b) totalnih odbroja, uzemljena elektroda velikog poluprečnika.

Kao što je napomenuto, zbog uslova pražnjenja može da se očekuje da će odbroji biti manji kada se snimanja masenim spektrometrom obavljaju u konfiguraciji sa uzemljenom elektrodom manjeg poluprečnika. Odbroji će dodatno da opadnu ukoliko se energija jonizujućih elektrona smanji sa 70 eV na 20 eV. Zbog toga što u dobijenim spektrima, pogotovo na malim snagama pražnjenja, detektovani signali postoje za svega nekoliko vrednosti m/Z, ponašanje određenih vrsta može da bude vrlo nepraktično pratiti samo preko u procenata zastupljenosti u ukupnom spektru. Na slici 2.2.45 a) su prikazani doprinosi molekuskog kiseonika koji su snimljeni sa energijom jonizujućih elektrona od 20 eV. Ono što odmah pada u oči je mali doprinos molekula u uslovima u kojima se očekuje da on bude veliki, na malim pritiscima i snagama. Ovo je, međutim, posledica načina na koji se doprinosi računaju. Na pritisku od 300 mTorr bez uključenog pražnjenja (0 W) i na snazi od 100 W su, pored minimalnog šuma i argona, u spektru su dobijeni samo O, H₂O i O₂. Bez uključene plazme je detektovano 0 atoma kiseonika, i 100 molekula vode. S obzirom da je tokom istog merenja izbrojano 300 O₂ čestica, dobijen je doprinos ove vrste od oko 65 % (zbog šuma i argona nije iznosio tačno 75 %). Sa povećanjem snage, na pritisku od 300 mTorr, rastu i odbroji molekula kiseonika sve do 300 W posle čega ostaju približno konstantni. I na pritiscima od 450 mTorr i 600 mTorr, osim na snagama od 0 W i 100 W, odbroji ali i doprinosi praktično ne zavise od primenjene snage.

Asimetrično kapacitivno spregnuto pražnjenje velike zapremine

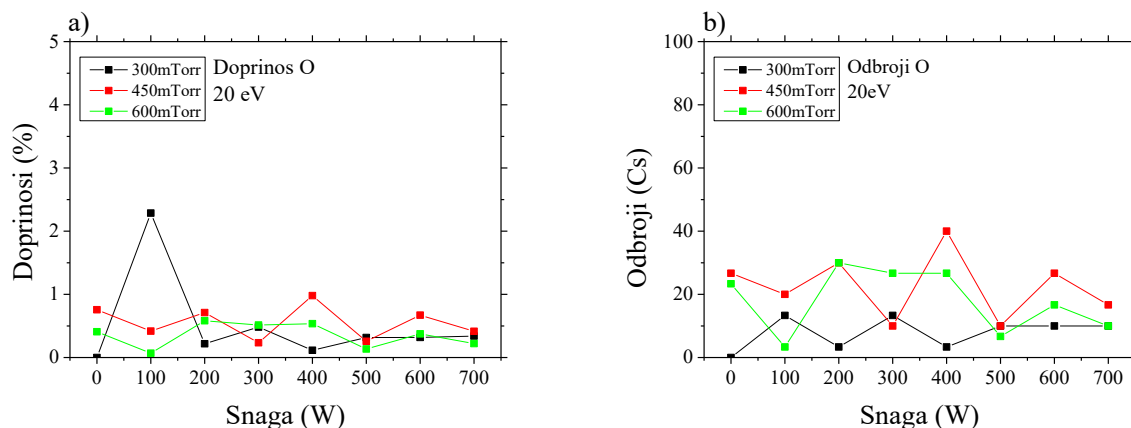

Slika 2.2.46 Doprinosi atomskog kiseonika u zavisnosti od pritiska i primenjene snage, snimljeni na energiji jonizujućih elektrona od 20 eV predstavljeni preko a) procenta udela u ukupnom spektru i b) totalnih odbroja, uzemljena elektroda velikog poluprečnika.

Kako se sa energijom jonizujućih elektrona podešenom na 20 eV, nalazimo ispod praga za disocijativnu jonizaciju O₂ molekula, možemo da pretpostavimo da najveći deo atoma kiseonika koji se na ovaj način izmere potiče iz same plazme, odnosno da nisu nastali unutar masenog spektrometra. Doprinosi O atoma, koji su prikazani na slici 2.2.46 a), su u skoro svim uslovima manji 1 % i vrlo nepravilno zavise kako od primenjene snage, tako i od pritiska. Ovakve, komplikovane zavisnosti, dobijene su kao posledica malih odbroja O atoma, koji su prikazani na slici 2.2.46 b). Nešto veći doprinos na pritisku od 300 mTorr i snazi od 100 W rezultat je numeričke procedure i problema koji je opisan u prethodnom pasusu.

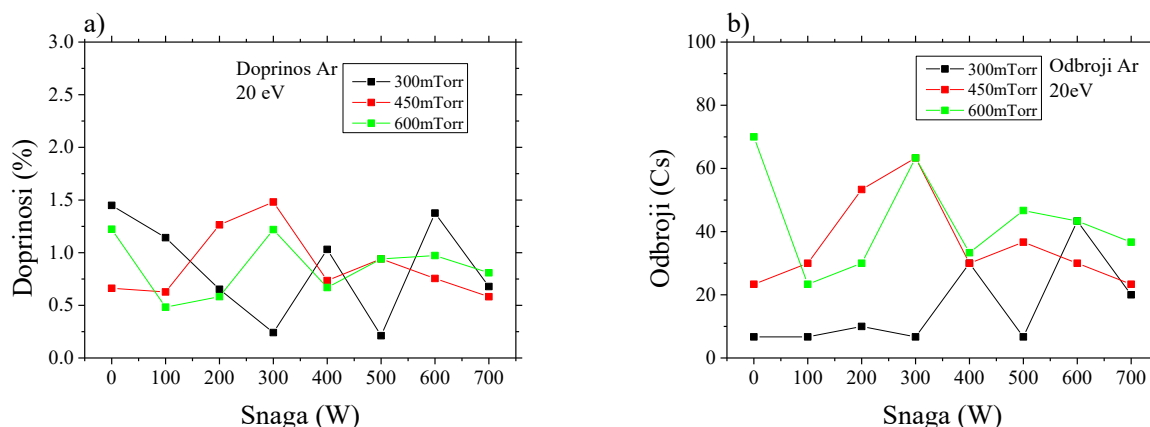

Slika 2.2.47 Doprinosi atomskog kiseonika u zavisnosti od pritiska i primenjene snage, snimljeni na energiji jonizujućih elektrona od 20 eV predstavljeni preko a) procenta udela u ukupnom spektru i b) totalnih odbroja, uzemljena elektroda velikog poluprečnika.

Podsetimo da je argon u smešu gasova dodat samo u cilju omogućavanja primene metode optičke aktinometrije. Sa udelom od 1 % u ukupnom broju čestica on ne može značajno da utiče ni na plazma hemijske reakcije ni na energijski bilans čestica. Meranjem doprinosa masenom spektrometrijom potvrđeno je da ni u jednom od uslova pražnjenja ne dolazi do značajnog odstupanja od ove vrednosti i da se aktinometrijska metoda može primeniti uz pretpostavku koncentracije argona

od jednog procenta u ukupnoj koncentraciji čestica. Doprinosi i odbroji ove vrste koji su dobijeni sa energijom jonizujućih elektrona od 20 eV su prikazani na slikama 2.2.47 a) i b). Do oscilacija dolazi zbog istih razloga kao i kod atomskog i molekuskog kiseonika.

2.2.3.3 Zaključak

Maseno energijskim analizatorom je ispitivan sastav plazme kao i uticaj faktora poput primenjene snage i pritiska na doprinose ključnih vrsta u pražnjenju. Vrste koje su praćene su pre svega one čiji smo protok kontrolisali, odnosno molekula kiseonika i atoma argona ali i vrste koje mogu da nastanu u pražnjenju, poput atoma kiseonika, ili se u komori pojavljuju kao primese zbog nesavršenosti sistema. Merenja su vršena na dve energije jonizujućih elektrona i u dve konfiguracije uzemljene elektrode. Kada je bila korišćena uzemljena elektroda većeg poluprečnika, doprinosi molekula kiseonika su, nakon određene granične vrednosti koja je bila veća na većem pritisku, opadali sa povećanjem snage, za obe energije jonizujućih elektrona. Sa druge strane, kada je bila postavljena dodatna, manja, uzemljena elektroda doprinosi su mnogo manje zavisili od promene snage, pogotovo kada je energija elektrona bila podešena na 20 eV. U svim uslovima pražnjenja doprinosi O₂ molekula su bili veći na većem pritisku. Doprinosi atomskog kiseonika koji su mereni sa energijom jonizujućih elektrona od 70 eV praktično nisu zavisili od primenjene snage a dobijene su vrlo slične vrednosti u obe konfiguracije uzemljenih elektroda. Sa druge strane na energiji od 20 eV su dobijeni značajno manji doprinosi O atoma tokom merenja sa velikom uzemljenom elektrodom, ali su u toj konfiguraciji odbroji ove vrste bili mnogo veći. Pokazano je da se doprinosi argona, atoma koji je u smešu dodat samo kako bi omogućio primenu metode optičke aktinometrije, u svim uslovima pražnjenja, u obe geometrije uzemljenih elektroda i na obe energije jonizujućih elektrona kreću oko 1 %. Takođe je pokazano da, zbog procedure merenja i načina računanja, nije uvek praktično prikazivati spektre samo preko doprinosa, već ih je poželjno, uporedo, prikazati i preko ukupnih odbroja. Posebno je problematično kada su odbroji mali pa i male oscilacije odbroja jedne vrste mogu da se preslikaju u značajne promene doprinosa neke druge vrste.

2.2.4 MASENA SPEKTROMETRIJA PRAGA ZA JONIZACIJU

Obična masena spektroskopija može da nam pruži podatke o prisustvu određenih vrsta u našem pražnjenju i njihovom udelu u ukupnom masenom spektru. Međutim, kao što je rečeno na početku prethodne glave i u uvodu, prilikom tretmana osetljivih uzoraka kiseoničnim plazmama veliku ulogu igraju pobuđene čestice, pogotovo prilikom tretmana bioloških uzoraka [2], [165]. Primenom klasične masene spektrometrije, s obzirom da se jonizacija vrši sa elektronima fiksne energije, gubi se informacija o tome da li su neutrali pre jonizacije bili pobuđeni ili ne. S druge strane merenjem odbroja u zavisnosti od energije jonizujućih elektrona, ova informacija ostaje sačuvana. Da podsetimo, sa našom opremom nismo u mogućnosti da detektujemo konkretna pobuđena stanja, poput singletnog delta stanja molekula koje nas najviše interesuje, ali možemo da odredimo ukupan broj pobuđenih čestica određene vrste koje su prikupljene masenim spektrometrom. U ovoj glavi će biti analizirano kako broj pobuđenih atoma i molekula kiseonika zavisi od parametara pražnjenja kao što su pritisak i primenjena snaga.

2.2.4.1 Uzemljena elektroda većeg poluprečnika

Primeri kriva koje su dobijene snimanjem odbroja molekula i atoma kiseonika u zavisnosti od energije jonizujućih elektrona prikazani su na slici 2.2.48. Snimljene su na pritisku od 450 mTorr, na snagama od 0 W (ugašeno pražnjenje) do 700 W. Kada je plazma ugašena, potrebno je da energija elektrona bude veća od praga za jonizaciju kako bi pomenute vrste uopšte mogle da budu detektovane. Sve do snage pražnjenja od 300 W detekcija ovih vrsta ostaje nemoguća ukoliko elektroni nemaju dovoljno veliku energiju. Tokom merenja na masi od 32 amu signal se pojavljuje tačno na energiji od 12,6 eV što odgovara pragu za jonizaciju molekula kiseonika (2.2.48a)). Sa druge strane, na masi koja odgovara atomu kiseonika (2.2.48 b)) će, na malim snagama pražnjenja, odbroji da budu merljivi tek na oko 15 eV. Ta vrednost je od praga za disocijativnu jonizaciju veća za više od 1 eV. Ova razlika, između detektovanog i teorijskog praga za jonizaciju, bi u određenoj meri mogla da se pripíše grešci u određivanju energije elektrona. Ipak, po uputstvu proizvođača ona iznosi $\pm 0,5$ eV, što je manje od primećene razlike. Dodatno u našim merenjima za prag jonizacije molekula greška je manja i od 0,1 eV. Međutim, kada se merenje vrši nad fragmentima disocijacije efikasnost sistema opada u velikoj meri [166]. Naime, nakon sudara sa elektronom se deo energije troši na samu disocijaciju molekula dok se deo energije pretvara u kinetičku energiju fragmenata [167]. Pored toga, treba imati u vidu i da brzine atoma nakon ovog sudara imaju određenu raspodelu po uglovima [168] odnosno da su praktično izbačeni iz snopa neutrala. Podsetimo da se neutralne čestice, pre nego što se jonizuju, kroz sistem masenog spektrometra kreću samo zbog postojanja gradijenta pritiska.

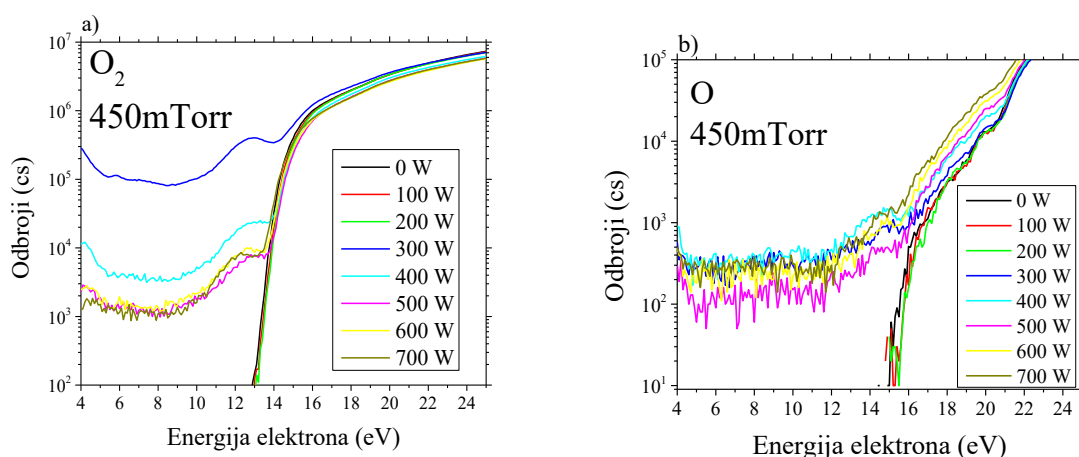

Slika 2.2.48 Odbroji u funkciji od energije elektrona snimljeni na različitim snagama pražnjenja za a) molekulski i b) atomski kiseonik na pritisku od 450 mTorr, uzemljena elektroda većeg poluprečnika

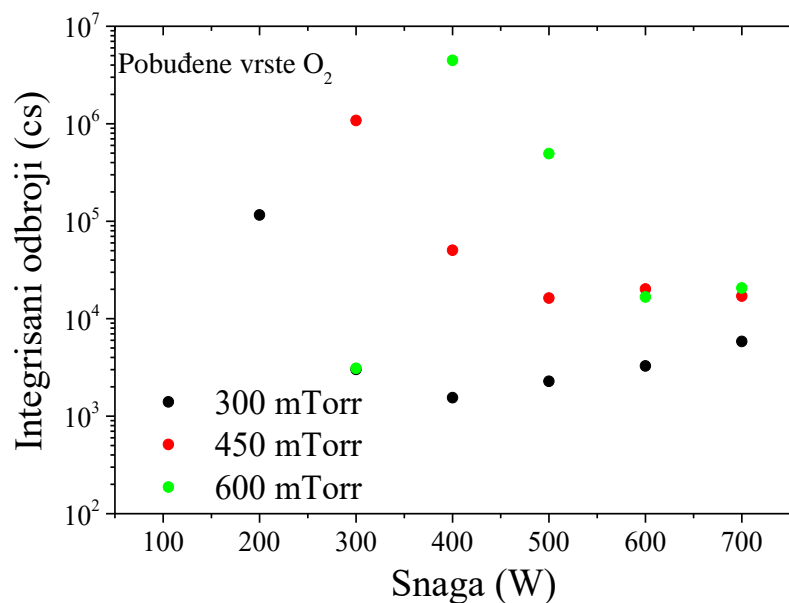

Slika 2.2.49 Integrirani odbroji pobuđenih molekula kiseonika u zavisnosti od snage i pritiska, uzemljena elektroda većeg poluprečnika

Integracijom kriva poput onih sa slike 2.2.48 a) od najmanje energije jonizujućih elektrona do praga za jonizaciju O₂ dobija se ukupni broj pobuđenih molekula koji su dospeli do otvora masenog spektrometra. Rezultati su prikazani na slici 2.2.49. Već smo pomenuli da je na malim snagama pražnjenja plazma skoncentrisana samo u maloj zapremini u neposrednoj blizini napajane elektrode. U takvim uslovima pobuđene čestice ne mogu da dođu do masenog spektrometra. Međutim, sa povećanjem snage detekcija pobuđenih vrsta postaje moguća. Treba primetiti da se na dva od tri pritiska na kojima su rađena merenja, maksimalni odbroji pobuđenih vrsta događaju upravo na tim minimalnim snagama koje su potrebne da njihova detekcija postane moguća. Na pritiscima od 300 i 450 mTorr se te granične vrednosti, ali i maksimalni odbroji pobuđenih vrsta, nalaze na 200 i 300 W respektivno. Međutim, na pritisku od 600 mTorr se minimalna snaga na kojoj je moguća detekcija nalazi na 300 W dok je najveći broj pobuđenih čestica izmeren na 400 W. Dalje povećanje primenjene snage, nakon što su postignuti maksimalni odbroji, dovodi do naglog opadanja količine pobuđenih molekula. Na pritisku od 600 mTorr taj pad iznosi čak dva reda veličine. Nakon početnog smanjenja, integrirani odbroji na sva tri pritiska dolaze do minimuma koji se nalaze 400 W (300 mTorr), 500 W (450 mTorr) i 600 W (600 mTorr). Dodatno povećanje snage će samo na najmanjem pritisku dovesti do sporog porasta izmerenih pobuđenih molekula, dok na druga dva pritiska neće dovesti do značajne promene.

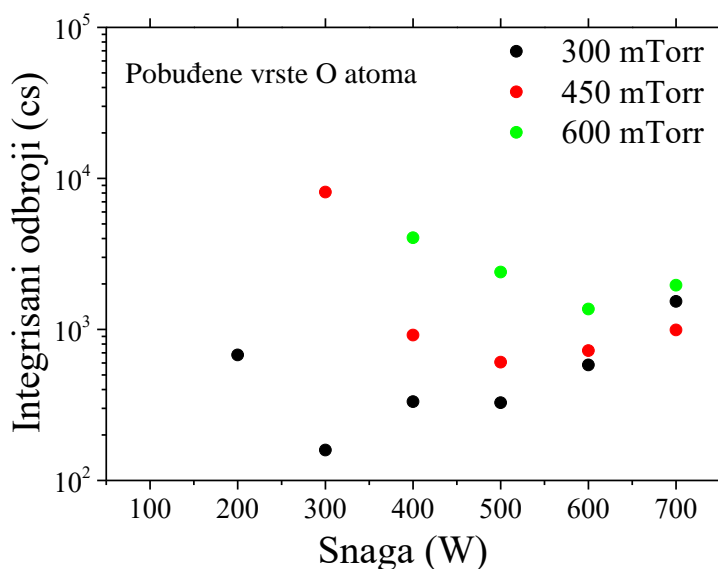

Slika 2.2.50 Integrirani odbroji pobuđenih atoma kiseonika u zavisnosti od snage i pritiska, uzemljena elektroda većeg poluprečnika

Integracijom krivi poput onih slici 2.2.48 b) dobijaju se odbroji pobuđenih O atoma. Njihova zavisnost od pritiska i primenjene snage je prikazana na slici 2.2.50. Kao i u slučaju molekula, postoje minimalne snage ispod kojih detekcija ovih vrsta nije moguća. Te minimalne snage iznose redom 200 W, 300 W i 400 W za merenja na pritiscima od 300 mTorr, 450 mTorr i 600 mTorr. Povećanje snage, kod atoma kao i kod molekula, u početku dovodi do naglog pada u broju pobuđenih čestica ali on u ovom slučaju neće biti veći od jednog reda veličine i najintenzivniji je na srednjem pritisku od 450 mTorr. Nakon što su dosegnute minimalne vrednosti, na svim pritiscima, integrirani odbroji će sa daljim povećanjem snage polako da rastu. Ukupni odbroji atoma su, zavisno od primenjene snage i pritiska, između 10 i 1000 puta manji od odbroja molekulskih pobuđenih vrsta. Takođe, u skoro svim uslovima merenja, više pobuđenih atoma je izmereno na višem pritisku.

2.2.4.2 Uzemljena elektroda manjeg poluprečnika

Primeri krive zavisnosti odbroja molekula kiseonika od energije jonizujućih elektrona, koje su snimljene kada je u komori bila postavljena uzemljena elektroda manjeg poluprečnika, su prikazani na slici 2.2.51. Snimljene su na različitim snagama pražnjenja na pritisku od 450 mTorr. Iako su totalni odbroji relativno niski, znatno manji nego tokom merenja u pražnjenju sa uzemljenom elektrodom velikog poluprečnika, pobuđene čestice se pojavljuju već na 100 W primenjene snage, odnosno čim je pražnjenje uključeno. Situacija je značajno drugačija kada se meri zavisnost odbroja atoma kiseonika od energije jonizujućih elektrona. Iz razloga koji su opisani u prethodnom poglavlju se, dodavanjem uzemljene elektrode manjeg poluprečnika, u oblasti ispred otvora za prikupljanje čestica nalaze molekuli mnogo manjih energija. Upravo zbog toga su i njihovi odbroji značajno manji. Međutim, u konfiguraciji sa dodatnom elektrodom, nisu postojali uslovi pražnjenja (ni snaga ni pritisak) na kojima je detekcija atoma bila moguća ispred praga za jonizaciju.

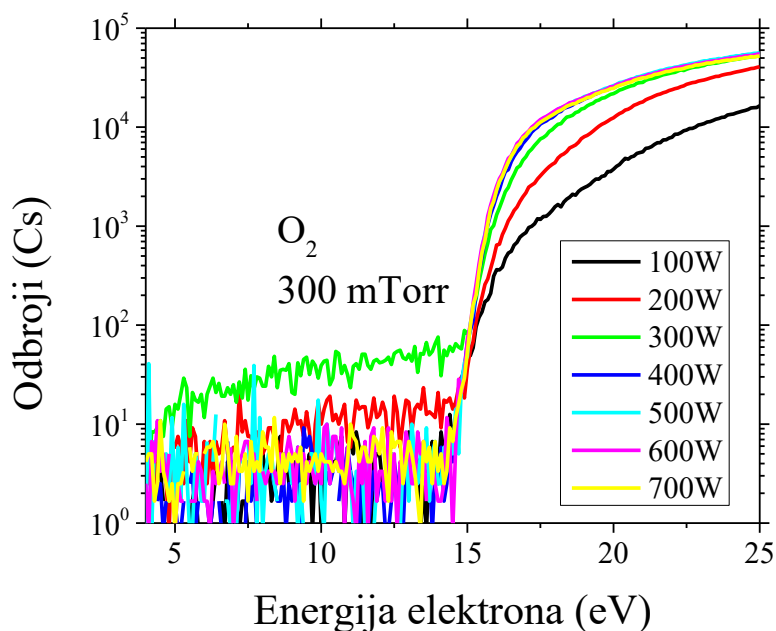

Slika 2.2.51 Odbroji molekula kiseonika u zavisnosti od energije jonizujućih elektrona na pritisku od 300 mTorr i različitim snagama pražnjenja, uzemljena elektroda manjeg poluprečnika.

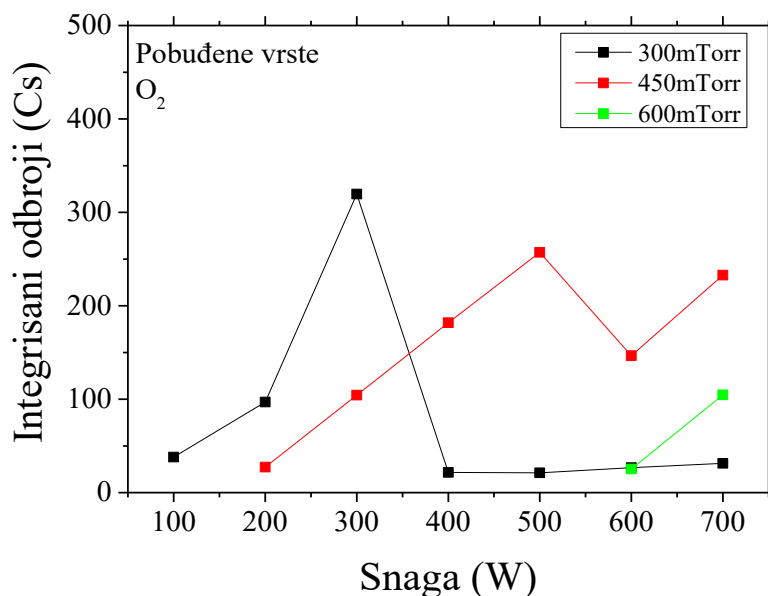

Slika 2.2.52 Integrirani odbroji pobuđenih molekula kiseonika u zavisnosti od snage i pritiska, uzemljena elektroda manjeg poluprečnika

Integrirani odbroji pobuđenih molekulskih vrsta su prikazani na slici 2.2.52 i znatno su drugačiji nego kad je merenje rađeno sa uzemljenom elektrodom velikog poluprečnika. Iako su odbroji značajno manji, pobuđene čestice, osim na najvećem pritisku, postaju merljive na nešto manjim snagama. Na pritiscima od 300 i 450 mTorr minimalne snage na kojima je detekcija moguća su za po 100 W manje nego tokom merenja sa elektrodom velikog poluprečnika i iznose 100 i 200 W. Međutim, na 600 mTorr, pobuđeni molekuli kiseonika postaju merljivi tek na snazi od 600 W. Čak i

u tim uslovima, odbroji su izuzetno mali. Maksimalni odbroj pobuđenih molekula, tokom merenja sa dodatnom uzemljenom elektrodom, je dobijen na snazi od 300W i na pritisku od 300 mTorr. Treba primetiti da je dobijena vrednost 2 reda veličine manja u odnosu na merenja na istom pritisku u prethodno opisanoj geometriji. Međutim, ukoliko se uporede totalni maksimumi koji su izmereni u dve različite konfiguracije uzemljenih elektroda, može se primetiti da su tokom merenja sa dodatnom elektrodom dobijene vrednosti koje su čak 5 redova veličine manje.

Pobuđene čestice kiseonikovog atoma u postavci sa manjom uzemljenom elektrodom nisu detektovane ni nakon višestruko ponovljenih merenja. S obzirom na to da rezultat nije bio drugačiji ni nakon merenja u kojima su parametri masenog spektrometra menjani u širokom opsegu, možemo sa sigurnošću da kažemo da u ovakvoj geometriji sistema one ili ne postoje u blizini uzemljene elektrode ili je njihov broj toliko mali da se one ne mogu detektovati opremom koja je nama na raspolaganju.

2.2.4.3 Zaključak

Merenjem prisustva pobuđenih vrsta atoma i molekula kiseonika je pokazano da veličina uzemljene elektrode ima veliki uticaj kako na njihove ukupne odbroje tako i na njihovu zavisnost od pritiska i primenjene snage. Korišćenjem uzemljene elektrode većeg poluprečnika dobijeni su odbroji pobuđenih vrsta kiseonikovog molekula koji su bili dva do pet redova veličine veći nego kada su merenja rađena sa postavljenom dodatnom, manjom, uzemljenom elektrodom. Takođe, pre postavljanja dodatnog uzemljenog cilindra su postojale minimalne snage ispod kojih se pobuđeni molekuli ne mogu detektovati. Na tim snagama je, osim na 600 mTorr izmeren i najveći broj pobuđenih O₂ molekula. S druge strane tokom merenja sa postavljenom dodatnom elektrodom su pobuđene čestice bile detektovane i na nešto manjim snagama, osim na najvećem pritisku, ali su njihovi odbroji bili znatno manji. Dodatna razlika je što je tokom korišćenja uzemljene elektrode velikog poluprečnika veći broj molekula bio izmeren na većem pritisku dok je u drugoj geometriji situacija bila obrnuta i maksimalni broj O₂^{*} molekula je dobijen na 300 mTorr. Najveća razlika između dve konfiguracije je ipak u prisustvu pobuđenih O atoma. Tokom merenja pre modifikacije komore su pobuđene atomske vrste imale zavisnosti od snage i pritiska koje su vrlo ličile na molekulske. Razlika je bila samo u totalnim odbrojima koji su, za atome, bili nešto niži. Međutim, kada je merenje rađeno u nivou uzemljene elektrode, ni u jednoj kombinaciji parametara pražnjenja (pritisk i snaga) pobuđeni atomi nisu detektovani. Do ovoga dolazi pre svega zato što je otvor za uzorkovanje, nakon postavljanja dodatne uzemljene elektrode, okružen efektivnim zidom komore na kome dolazi do rekombinacija atoma u molekule kiseonika. Ovaj fenomen je primećen i tokom merenja koncentracije atoma kiseonika katalitičkom sondom, kada je približavanjem zidu komore dolazilo do naglog pada koncentracije. Dodatni razlog za postojanje tako velike razlike u rezultatima leži i u relativnoj poziciji tačke na kojoj se vrši merenje. Naime, tokom pražnjenja sa elektrodom većeg poluprečnika se otvor za uzorkovanje masenog spektrometra nalazi u aktivnoj oblasti pražnjenja, dok se postavljanjem dodatne uzemljene elektrode merna pozicija nalazi praktično na uzemljenom zidu komore. S obzirom na to da je i maseni spektrometar uzemljen, prielektrodna oblast će se formirati ispred otvora za uzorkovanje i kada se on nalazi u nivou uzemljene elektrode i kada se nalazi u aktivnoj oblasti pražnjenja. Ove dve prielektrodne oblasti, koje nastaju oko masenog spektrometra za dve različite geometrije uzemljenih elektroda neće biti iste, što direktno utiče na razliku u energiji čestica koje se u ovim oblastima nalaze. Kao rezultat ova dva faktora, pre svega zbog blizine efektivnog zida komore, u nivou uzemljene elektrode, nisu uopšte detektovane pobuđene atomske vrste. To znači da ukoliko želimo da u ovakvom reaktoru obavljamo tretmane kojima pogoduje prisustvo pobuđenih kiseonikovih vrsta, bilo bi najbolje da uzorci stoje na postolju od provodnog materijala koje bi, kao i maseni spektrometar tokom merenja bez dodatne elektrode, bilo u električnom kontaktu sa uzemljenjem ali bi se njena gornja površina nalazila u prostoru između

napajane i uzemljene elektrode. Međutim ukoliko se tretiraju osetljivi uzorci, što je bila i osnovna namena konstrukcije ovakvog reaktora, trebalo bi ih postaviti na samu uzemljenu elektrodu jer će na taj način u najvećoj meri biti zaštićeni od delovanja pobuđenih molekula i atoma.

2.2.5 OPTIČKA EMISIONA SPEKTROSKOPIJA I AKTINOMETRIJA

U ovom poglavlju će biti predstavljeni rezultati merenja optičkim metodama. Biće predstavljeni spektri koji su dobijeni metodom optičke aktinometrije ali i stepen disocijacije molekulskog kiseonika i apsolutna koncentracija atomskog kiseonika koji su dobijeni primenom tehnike optičke aktinometrije. Merenja su rađena snimanjem spektara sa prednje strane komore i kroz bočni prozor na komori. Takođe, svetlost je skupljana iz oblasti u nivou napajane elektrode i u nivou uzemljenog postolja za uzorke. Merenja su rađena u dve, već pomenute, konfiguracije uzemljene elektrode. Zbog rasporeda otvora na komori i geometrije dodatne uzemljene elektrode, bočna merenja u nivou uzemljene elektrode nismo bili u mogućnosti da uradimo.

2.2.5.1 Uzemljena elektroda većeg poluprečnika

Princip rada i mogućnosti aktinometrijske metode su objašnjene u uvodnoj glavi disertacije i u poglavlju 2. glave koja se bavila eksperimentalnom postavkom. U našim eksperimentima je ova metoda korišćena za merenje disocijacije O₂ molekula i koncentracije O atoma. Kao aktinometar, gas poznate koncentracije, je korišćen argon čija je koncentracija računata iz jednačine stanja idealnog gasa. Merenjima masenom spektrometrijom je pokazano da može da se pretpostavi da će ukupni sadržaj argona iznositi 1 % ukupne koncentracije čestica u komori. Odnosno, pretpostavili smo da parcijalni pritisak argona iznosi 1 % ukupnog pritiska.

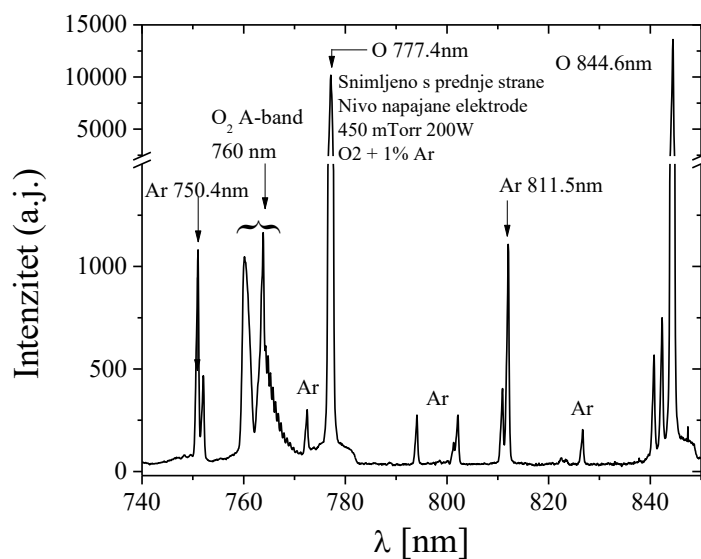

Slika 2.2.53 Emisioni spektar snimljen sa prednje strane komore (450 mTorr, 200 W) u nivou napajane elektrode sa naznačenom molekulskom trakom kiseonika i atomskim linijama kiseonika i argona.

Na slici 2.2.53 nalazi se spektar emisije zračenja iz našeg pražnjenja koji je snimljen sa prednje strane komore. Svetlost je prikupljena iz oblasti oko napajane elektrode na pritisku od 450 mTorr dok je snaga pražnjenja iznosila 200 W. Vidljivo je prisustvo molekulske trake kiseonika i nekoliko intenzivnih linija atomskog kiseonika i argona. Najintenzivnije linije argona nalaze se na 750,4 nm i 811,5 nm dok se intenzivno zračenje O atoma odvija na talasnim dužinama od 777,4 nm i 844,6 nm. Vidljivo je još nekoliko argonovih linija ali, zbog slabog intenziteta, one nisu uzete u razmatranje.

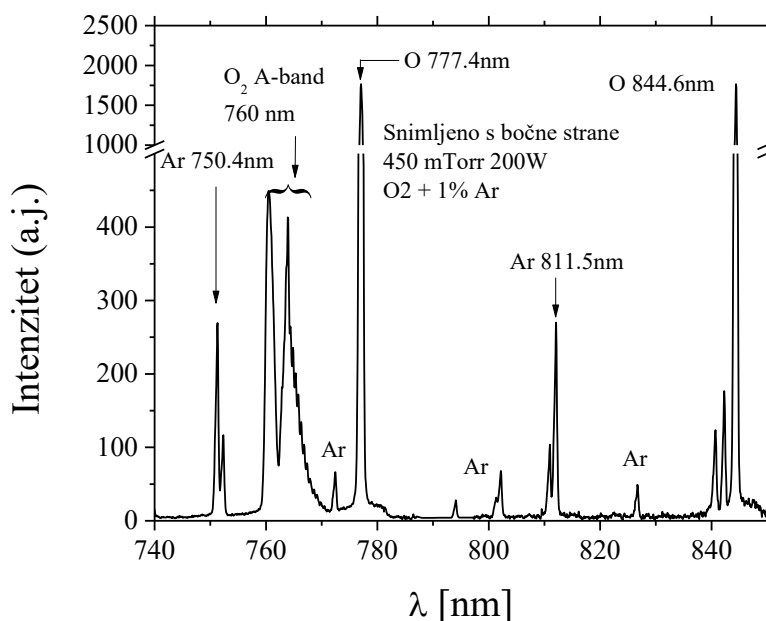

Slika 2.2.54 Emisioni spektar snimljen sa bočne strane komore (450 mTorr, 200 W) u nivou napajane elektrode sa naznačenom molekulsom trakom kiseonika i atomskim linijama kiseonika i argona

Optički spektar u istom opsegu talasnih dužina i za iste uslove pražnjenja, ali koji je snimljen kroz bočni prozor na komori je prikazan na slici 2.2.54. Iako je intenzitet meren u arbitrarnim jedinicama, jasno je da je intenzitet zračenja koji izmeren kroz bočni prozor znatno manji nego kada je snimanje obavljeno sa prednje strane komore. Ovo nije neočekivan rezultat jer tokom snimanja sa prednje strane komore se svetlost prikuplja iz oblasti koja dugačka koliko i elektroda, dok se kroz bočni prozor vidi samo jedan njen mali deo. Podsetimo se da je elektroda dugačka 1,5 m a da je komora, od zida do zida, široka ukupno 117 cm. Takođe svetljenje, vidljivo golim okom, je skoncentrisano samo u oblasti pražnjenja u neposrednoj blizini napajane elektrode. Međutim, iako je intenzitet zračenja na ovoj poziciji manji, iste četiri atomske linije dominiraju u spektru. U našim aktinometrijskim merenjima će biti korišćena linija atomskog kiseonika koja se nalazi na 844,6 nm i linija argona koja se nalazi na 811,5 nm.

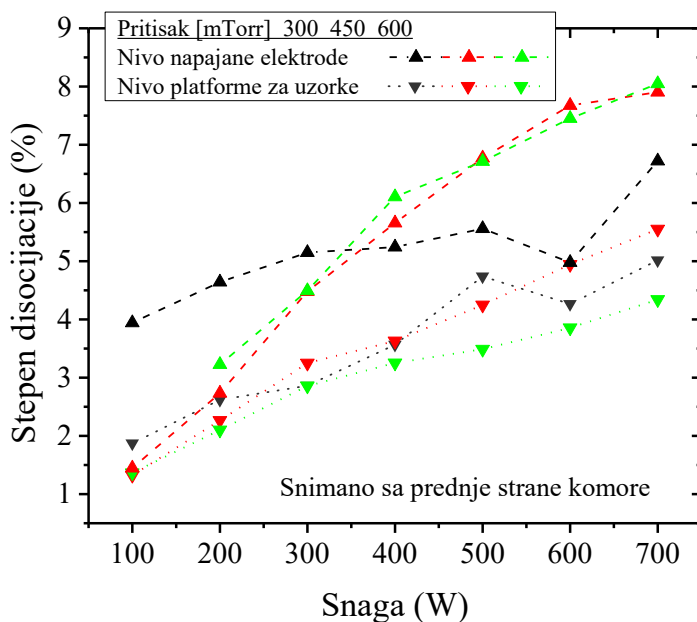

Slika 2.2.55 Stepen disocijacije O₂ molekula dobijen iz spektroskopskih snimaka sa prednje strane komore na tri različita pritiska. Podaci su dobijeni iz snimaka napravljenih u nivou elektrode (trouglovi koji pokazuju na gore) i u nivou platforme za uzorke (trouglovi koji pokazuju na dole)

Zavisnost stepena disocijacije molekulskog kiseonika od primenjene snage je prikazana na slici 2.2.55 za tri različita pritiska i dve merne pozicije. Spektri su snimani sa prednje strane komore u nivou napajane elektrode i u nivou postolja za uzorke. Zbog veličine i pozicije prozora u nivou postolja za uzorke i veličine komore, u efektivni prostorni ugao koji je obuhvaćen snimanjem sa ove pozicije je u jakoj maloj meri dolazila emisija iz oblasti oko elektrode, pa praktično celokupna snimljena emisija potiče iz oblasti u kojoj nema intenzivnog svetljenja. Stepen disocijacije, na malim snagama, u nivou platforme za uzorke je vrlo sličan za sva tri pritiska. Međutim, sa povećanjem snage se vidi i jasnija razlika u stepenu disocijacije zavisno od pritiska. U nivou postolja za uzorke je najviše molekula disosovalo na pritisku od 450 mTorr na snazi pražnjenja od 700 W kada je stepen disocijacije iznosio oko 5,5 %. Nešto veća disocijacija je izmerena u nivou napajane elektrode. Na najmanjem pritisku je zavisnost od primenjene snage slaba i sve do 600 W se kreće između 4 i 5 %. Veliki skok se događa tek na snazi od 700 W kada je stepen disocijacije dostigao 6,7 %. Na dva veća pritiska su, za sve primenjene snage, dobijene skoro identične vrednosti i kreću se od minimalnih 1,4 % na snazi od 100 W i 450 mTorr do maksimalnih 8 % na pritisku od 600 mTorr i snazi od 700 W. Ukoliko stepene disocijacije uporedimo sa onima koji su dobijeni primenom masene spektrometrije, vidimo da su aktinometrijskom metodom dobijene nešto veće vrednosti. Sa energijom jonizujućih elektrona od 20 eV je dobijeno svega 0,3 % atomskog kiseonika u ukupnom masenom spektru dok je na energiji od 70 eV njegov udeo iznosio maksimalnih 6%. Velika razlika u stepenima disocijacije izmerenim sa ove dve metode u nivou postolja za uzorke može da se objasni različitim oblastima u kojoj se parametar meri i samom geometrijom komore. Naime, aktinometrijom se određuje ukupni stepen disocijacije u nekoj zapremini integracijom signala duž linije posmatranja dok se masenom spektrometrijom uzorkuje u jednoj maloj zapremini, odnosno praktično u jednoj tački prostora. Takođe, treba imati u vidu i da se postolja za uzorke, u poređenju sa otvorom za uzorkovanje masenog spektrometra, nalazi na nešto većoj udaljenosti od napajane elektrode. Sa druge strane, iako je tokom snimanja emisije iz plazme na poziciji platforme gornji deo prozora bio maskiran, kako bi se prikupilo što manje svetlosti iz delova komore koji su blizu napajane elektrode, zbog velikih dimenzija reaktora nije bilo moguće postaviti sabirno sočivo i spektrometar na takav način da se to potpuno spreči.

Takođe, određena količina svetlosti može da dođe do detektora nakon refleksija sa unutrašnje strane reaktora.

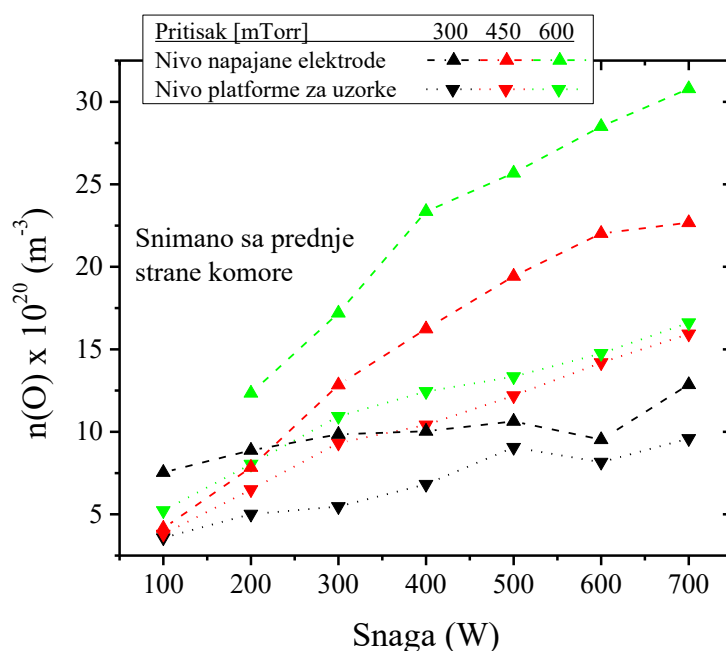

Slika 2.2.56 Koncentracija O atoma dobijena aktinometrijom iz spektroskopskih snimaka sa prednje strane komore na tri različita pritiska. Podaci su dobijeni iz snimaka napravljenih u nivou elektrode (trouglovi) i u nivou platforme za uzorke (obrnuti trouglovi)

Koncentracija atomskog kiseonika u zavisnosti od snage, na sva tri pritiska i obe merne pozicije sa prednje strane komore, je prikazana na slici 2.2.56. U nivou postolja za uzorke su dobijene vrlo slične vrednosti koncentracija na pritiscima od 450 i 600 mTorr. Koncentracija O atoma raste sa povećanjem primenjene snage i, na ovoj mernoj poziciji, će imati maksimalnu vrednost od $1,6 \times 10^{21} \text{ m}^{-3}$. Na pritisku od 300 mTorr je zavisnost od snage nešto manje izražena iako je primetan pozitivan trend tako da je maksimum dobijen na snazi od 700 W i iznosi $9,6 \times 10^{20} \text{ m}^{-3}$. Na najmanjem pritisku, mereno u nivou napajane elektrode, je zavisnost od snage još slabije izražena tako da se u celom opsegu ona kreće između $7,5 \times 10^{20} \text{ m}^{-3}$ i $1,29 \times 10^{21} \text{ m}^{-3}$. Značajno veće koncentracije O atoma su dobijene na pritisku od 450 mTorr na kome dostižu maksimalnu vrednost od $2,27 \times 10^{21} \text{ m}^{-3}$. Ipak, uz izraženu zavisnost od primenjene snage, najveća koncentracija atomskog kiseonika u našem reaktoru je dobijena na pritisku od 600 mTorr. Dobijena je na snazi pražnjenja od 700 W i iznosi $3,08 \times 10^{21} \text{ m}^{-3}$.

Merenja koncentracije atomskog kiseonika su u ovom reaktoru, u nešto drugačijim eksperimentalnim uslovima, obavljena katalitičkom sondom [169] koja meri koncentraciju atoma kiseonika u jednoj tački. Naime u pražnjenju u vazduhu kada je sonda bila na jednakoj udaljenosti od napajane elektrode kao i postolja za uzorke, na snazi od 500 W i pritisku od 600 mTorr, dobijena je vrednost koncentracije od oko $1 \times 10^{19} \text{ m}^{-3}$. Aktinometrijskom metodom su, za iste uslove, dobijene vrednosti koje su za dva reda veličine veće. Jedan od razloga za ovoliku razliku leži i u činjenici da je koncentracija molekuskog kiseonika u korišćenim radnim gasovima bila drugačija. Pored toga što je parcijalni pritisak O_2 molekula manji, drugačiji sastav radnog gasa podrazumeva i različitu raspodelu energija kako za elektrone tako i za teže čestice, što kao posledicu daje drugačiju količinu O atoma u reaktoru. Ovo, međutim, ne može da bude dovoljan razlog za tako veliko neslaganje. Dodatni uzrok leži i u primenjenim dijagnostičkim metodama. Naime, iako je direktno poređenje

lokalnog merenja sondom i aktinometrijske metode koja daje prostorno usrednjene i integralne vrednosti nemoguće, možemo da pretpostavimo dva uzorka koji dovode do ovako velike razlike u rezultatima. S jedne strane vrednost koncentracije dobijene aktinometrijskom metodom, je verovatno malo precenjena, kako zbog integracije duž pravca posmatranja tako i zbog svetlosti koja je prikupljena iz drugih delova reaktora zbog njegovih dimenzija. Sa druge strane, pre merenja katalitičkom sondom je poželjno njenu površinu izložiti visokoj temperaturi kako bi se ona adekvatno aktivirala. Malo potcenjene vrednosti koje su dobijene katalitičkom sondom mogu da se jave i kao posledica toga što u našoj laboratoriji nismo mogli da postignemo dovoljno velike temperature. Potvrdu pretpostavke da su vrednosti disocijacije O₂ molekula i koncentracije atomskog kiseonika koje su dobijene aktinometrijskom metodom nešto veće od realnih, na velikim udaljenostima od napajane elektrode, možemo da nađemo i poređenjem sa predstavljenim rezultatima masene spektrometrije. Iako je masena spektrometrija takođe lokalna metoda i otvor za uzorkovanje kod masenog spektrometra se nalazi na nešto manjem rastojanju od napajane elektrode nego platforma za uzorke, dobijeni stepen disocijacije (odnosno doprinos atomskog kiseonika u ukupnom spektru) je takođe za ceo red veličine manji u poređenju sa aktinometrijskim merenjima. Treba imati na umu da rezultati aktinometrijske metode i masene spektrometrije, opet zbog suštinskih razlika u metodi merenja, ne mogu direktno da se porede ali je ipak određene paralele između njih moguće povući.

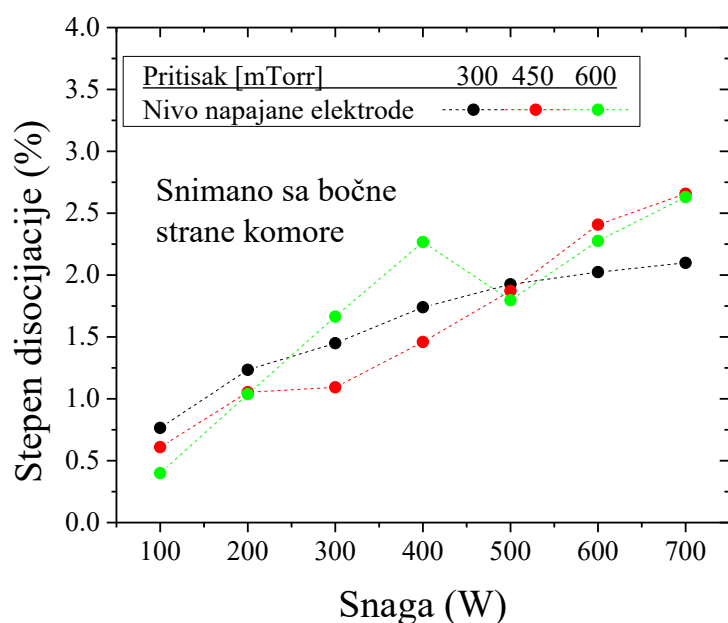

Slika 2.2.57 Stepen disocijacije O₂ molekula dobijen iz spektroskopskih snimaka sa bočne strane komore na tri različita pritiska

Stepen disocijacije koji je izmeren aktinometrijskom metodom, snimanjima kroz bočni prozor na komori, je prikazan u zavisnosti od primenjene snage i pritiska na slici 2.2.57. Na sva tri pritiska će povećanje primenjene snage dovesti do povećanja stepena disocijacije. Dobijene vrednosti su nešto niže od onih koje su dobijene snimanjima sa prednje strane komore u nivou elektrode i više nego duplo niže od rezultata dobijenih iz spektara sa nivoa napajane elektrode. Ovo je posledica geometrije reaktora, odnosno oblasti iz koje je svetlost prikupljena. Bočnim snimanjima se svetlost prikuplja iz prielektrodne oblasti napajane elektrode, iz aktivnog dela plazme uključujući i delove koji su daleko od napajane elektrode ali i iz prielektrodne oblasti uzemljene elektrode. Ovo su oblasti u kojima se koncentracije atomskog i molekulskog kiseonika značajno menjaju ali je jasno da će, zbog udaljenosti od napajane elektrode, u najvećem delu ove zapremine koncentracija molekula biti značajno veća od

koncentracije atoma. Poređenjem linija koju emituju ove dve vrste će se posledično dobiti manji stepen disocijacije. Na malim snagama stepen disocijacije za sva tri ispitana pritiska je sličan, dok su najveće razlike, za različite pritiske, dobijene na snazi od 700 W. Stepenn disocijacije na pritisku od 300 mTorr najmanje zavisi od primenjene snage i u ukupnom opsegu se promeni od 0,75 do 2,1 %. Osim na snagama od 300 i 400 W stepenn disocijacije na dva viša pritiska, 450 mTorr i 600 mTorr, je praktično identičan. Kreće se od oko 0,5 % na najmanjoj primenjenoj snazi do nešto više 2,6 % na najvećoj snazi.

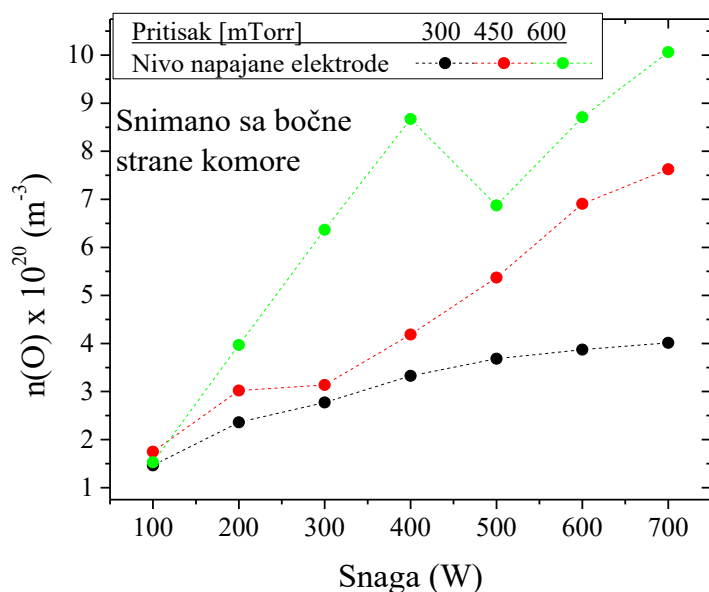

Slika 2.2.58 Koncentracija O atoma dobijena iz spektroskopskih snimaka sa bočne strane komore na tri različita pritiska

Koncentracija atomskog kiseonika u zavisnosti od snage na sva tri pritiska, dobijena iz spektara koji su snimljeni kroz bočni prozor, je prikazana na slici 2.2.58. Dobijene koncentracije imaju nešto izraženiju zavisnost od pritiska, odnosno veće koncentracije su izmerene na većem pritisku. Jedino na najmanjoj snazi pražnjenja, od 100 W, su na sva tri pritiska dobijene skoro iste vrednosti od oko $1,5 \times 10^{20} \text{ m}^{-3}$. Na 600 mTorr postoji izraženi minimum koncentracije na 500 W posle čega će, sa daljim povećanjem snage, i koncentracija atomskog kiseonika nastaviti da raste. Kao i stepenn disocijacije, i vrednosti apsolutne koncentracije atomskog kiseonika su manje kada je merenje obavljano kroz bočni prozor u odnosu na ona koja su obavljana kroz prednji, duž napajane elektrode.

2.2.5.2 Uzemljena elektroda manjeg poluprečnika

Tokom aktinometrijskih snimanja, kada je u komori bila postavljena uzemljena elektroda manjeg poluprečnika, korišćen je spektrometar OceanSight Maya 2000 sa optičkim vlaknom (M114L02) i sočivom (Ocean Optics UV74). Sočivo je propusno za talasne dužine u opsegu od 185 nm do 2005 nm i poseduje adapter koji omogućava pričvršćivanje optičkog vlakna u žiži sočiva. Tokom merenja je bilo postavljeno uz sam prozor komore na odgovarajućem stalku. U opsegu talasnih dužina od 200 do 900 nm korišćeno vlakno propušta 99 % svetlosti a nalazi se u omotaču čiji je spoljašnji prečnik 3 mm a unutrašnji 1 mm sa numeričkom aperturom od 0,22. CCD detektor u

spektrometru je namenjen za snimanje spektara u oblasti između 165 i 1100 nm, u okviru koje se nalaze i talasne dužine koje nas zanimaju, odnosno linija kiseonikovog atoma na 844,6 nm i linija argona na 811,5 nm. Nakon snimanja signala a pre dalje analize urađena je korekcija intenziteta u zavisnosti od kvantne efikasnosti sistema. S obzirom na to da je korišćena drugačija oprema za snimanje emisionog spektra nego u slučaju uzemljene elektrode velikog poluprečnika (glava 2.2.5.1), nije moguće direktno poređenje apsolutne vrednosti emisije linija iz spektara koje su dobijene tokom pražnjenja sa dve različite konfiguracije uzemljenih elektroda. Međutim, kako se aktinometrijska metoda zasniva na odnosu intenziteta linija različitih vrsta, aktinometrijski određene koncentracije atomskog kiseonika i stepen disocijacije O₂ molekula iz dve konfiguracije se mogu porediti.

Postavljanjem uzemljene elektrode manjeg poluprečnika u komoru, spektroskopska snimanja su moguća na dve pozicije. Postolje za uzorke se kod elektrode manjeg poluprečnika praktično nalazi na spoljnoj strani reaktora pa u oblasti oko njega nema emisije. Emisioni spektar zračenja u opsegu od 200 nm do 900 nm, koji je snimljen sa prednje strane komore, tokom pražnjenja na pritisku od 450 mTorr i snazi od 500 W, je prikazan na slici 2.2.59. Za razliku od spektra koji je na istoj poziciji dobijen tokom pražnjenja bez dodatne uzemljene elektrode, linija kiseonika na talasnoj dužini od 844,6 nm više nije najintenzivnija. Linija argona na 811,6 nm je ostala najintenzivnija linija ovog atoma. Pored ove dve linije, vidljiva je i linija kiseonika na 777,4 nm ali i traka molekulskog kiseonika na 760 nm i još jedna linija argona na 750,4 nm. Sve ostale linije u spektru imaju značajno manji intenzitet od pomenutih.

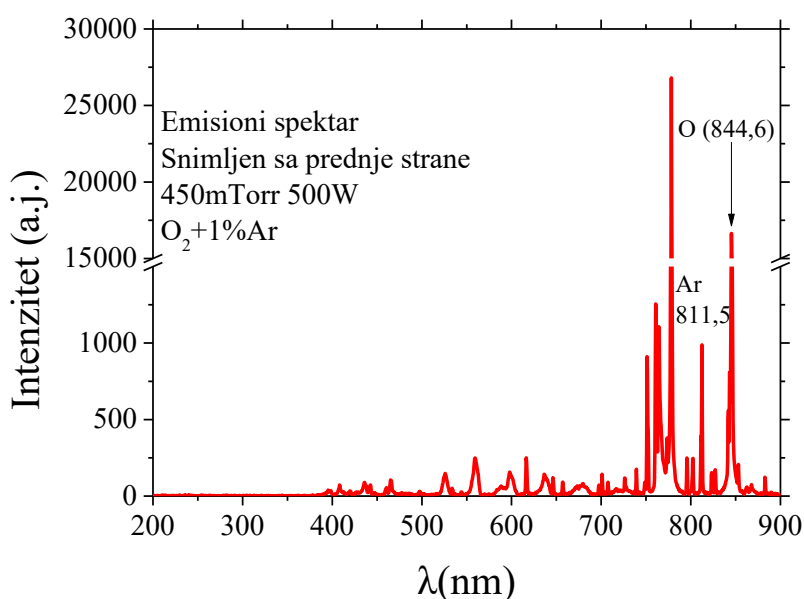

Slika 2.2.59 Emisioni spektar snimljen sa prednje strane komore (450 mTorr, 500 W) u nivou napajane elektrode sa naznačenim linijama koje će biti korišćene u aktinometrijskim proračunima.

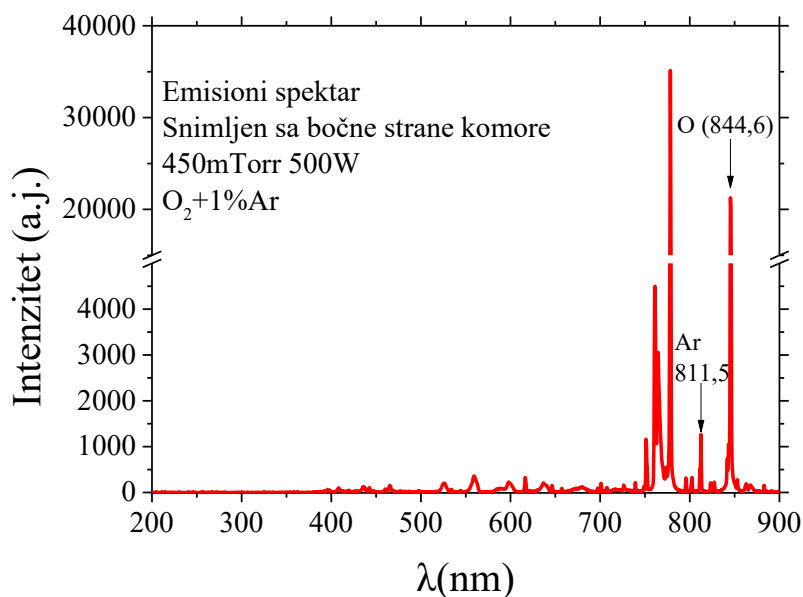

Slika 2.2.60 Emisioni spektar snimljen sa bočne strane komore (450 mTorr, 500 W) sa naznačenim linijama koje će biti korišćene u aktinometrijskim proračunima.

Primer spektra koji je dobijen snimanjem sa bočne strane komore u istim uslovima pražnjenja (450mTorr, 500W) je dat na slici 2.2.60. Linija O atoma na 777,4 nm je i dalje najintenzivnija u spektru sa intenzitetom koji je oko 35 % veći u odnosu na onaj koji je dobijen snimanjem sa prednje strane komore. Intenzitet svih ostalih linija, koje su izmerene sa bočne strane reaktora, je takođe veći što je suprotna situacija u odnosu na merenja sa većom uzemljenom elektrodom, kada su intenziteti svih linija bili veći tokom snimanja sa prednje strane.

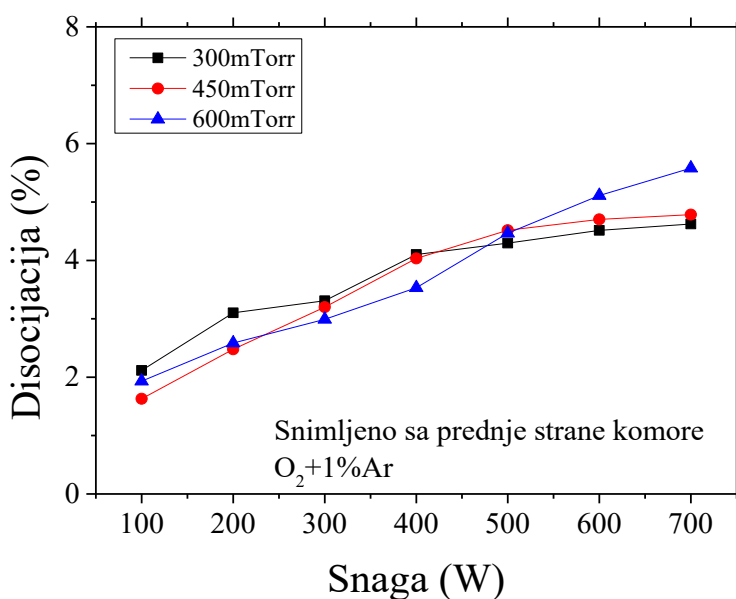

Slika 2.2.61 Stepen disocijacije O₂ molekula dobijen iz spektroskopskih snimaka sa prednje strane komore na tri različita pritiska.

Iz izmerenih spektara, korišćenjem aktinometrijske metode, određen je stepen disocijacije O_2 i koncentracija atoma kiseonika. Kao što je i očekivano, stepen disocijacije O_2 molekula raste sa povećanjem primenjene snage kao što se vidi na slici 2.2.61. Na manjim snagama je disocijacija najveća na pritisku od 300 mTorr. Povećanjem snage će disocijacija imati praktično istu vrednost na sva tri pritiska sve do 500 W, posle čega dolazi do nešto primetnijeg skoka disocijacije na 600 mTorr dok na dva niža pritiska neće doći do značajnije promene.

Stepen disocijacije koji je izračunat iz spektara dobijenih snimanjem sa bočne strane komore je, za tri pritiska, prikazan na slici 2.2.61. Dobijene vrednosti su nešto više u odnosu na rezultate koji su dobijeni iz snimaka sa prednje strane i kreću se od 2 do 6 %. Ova situacije je, takođe, obrnuta u odnosu na merenja bez dodatne elektrode tokom kojih su bočnim snimanjima dobijene niže vrednosti. Ukoliko se podsetimo da se nakon postavljanja uzemljene elektrode manjeg poluprečnika dobijaju veće struje i efikasnosti predaje snage ali da maseni spektrometar detektuje manje O atoma, dok pobuđeni atomi nisu uopšte primećeni, možemo da zaključimo dve stvari. Efektivnim približavanjem uzemljene elektrode napajanoj se dobija nešto intenzivnije pražnjenje (veće struje) ali se sama površina uzemljene elektrode praktično ponaša kao ponor za atome. Odnosno, na njoj dolazi do rekombinacije atoma u molekule ali i sami molekuli gube značajan deo energije usled čega je, na toj poziciji, manje atoma kiseonika u masenom spektru.

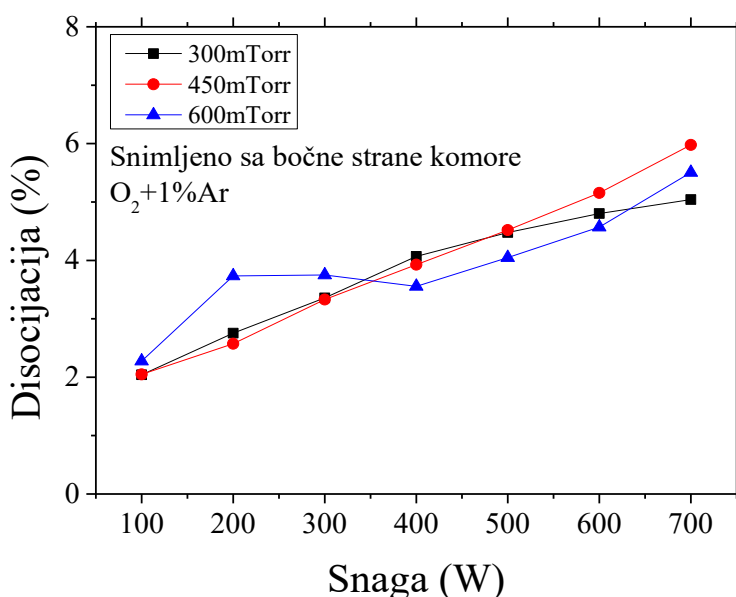

Slika 2.2.62 Stepen disocijacije O_2 molekula dobijen iz spektroskopskih snimaka sa bočne strane komore na tri različita pritiska.

Koncentracije atoma kiseonika, koje su dobijene iz spektara snimljenih sa prednje strane komore kada je u sistemu postavljena dodatna uzemljena elektroda, su nešto manje nego za slučaj kada ona nije bila postavljena a njihova zavisnost od pritiska i primenjene snage je prikazana na slici 2.2.63. Očekivano, koncentracija raste sa povećanjem kako pritiska tako i primenjene snage. Na 300 mTorr dolazi do najvećeg porasta između 100 i 400 W dok na snagama koje su veće od 400 W koncentracija O atoma vrlo slabo zavisi od primenjene snage. Na 450 mTorr je dobijena slična zavisnost od primenjene snage s tim što do platoa dolazi tek na snagama koje su veće od 500 W. Na

Asimetrično kapacitivno spregnuto pražnjenje velike zapremine

najvećem pritisku je ova zavisnost nešto drugačija pa do najintenzivnijeg porasta koncentracije dolazi upravo između 400 i 500 W, a u opsegu snaga koji je korišćen ne pojavljuje se vidljivi plato.

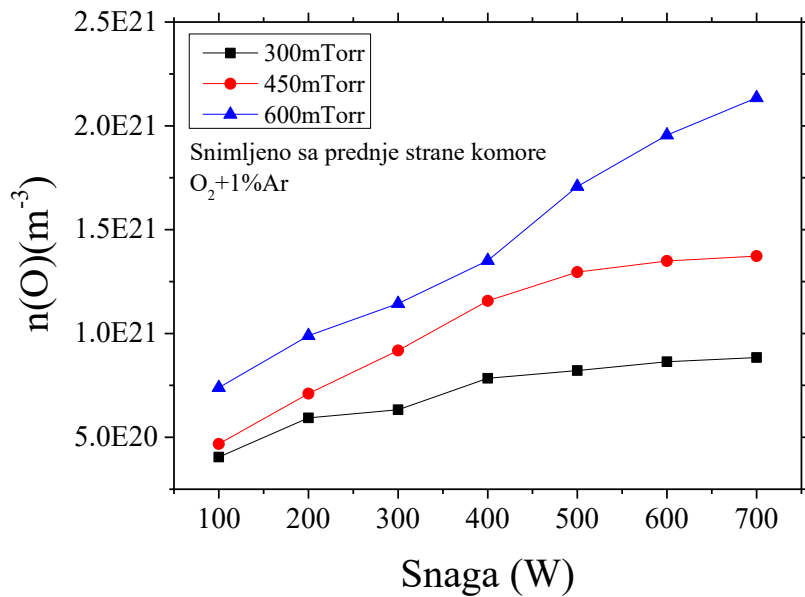

Slika 2.2.63 Koncentracija O atoma dobijena iz spektroskopskih snimaka sa prednje strane komore na tri različita pritiska.

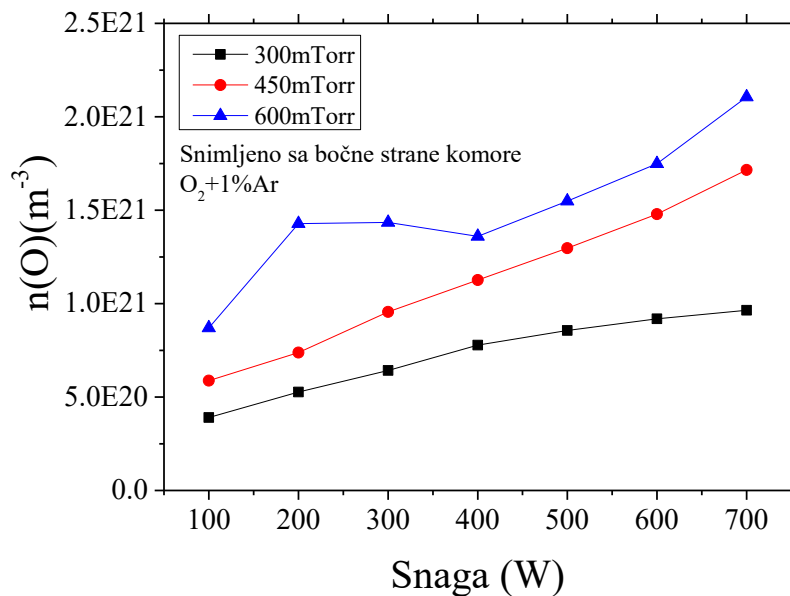

Slika 2.2.64 Koncentracija O atoma dobijena iz spektroskopskih snimaka sa bočne strane komore na tri različita pritiska.

Vrlo slične, mada nešto veće, vrednosti koncentracije O atoma su dobijene iz spektara koji su snimljeni kroz bočni prozor a prikazane su na slici 2.2.64. Najveća promena je zabeležena na

600 mTorr, jer između 200 i 400 W postoji čak i pad koncentracije O atoma, dok su maksimalna i minimalna vrednost, za dve različite pozicije snimanja, na ovom pritisku skoro identične. Dodatno, na 450 mTorr plato više ne postoji a zavisnost od snage je praktično linearna. Na 300 mTorr na velikim snagama rast koncentracije je nešto sporiji.

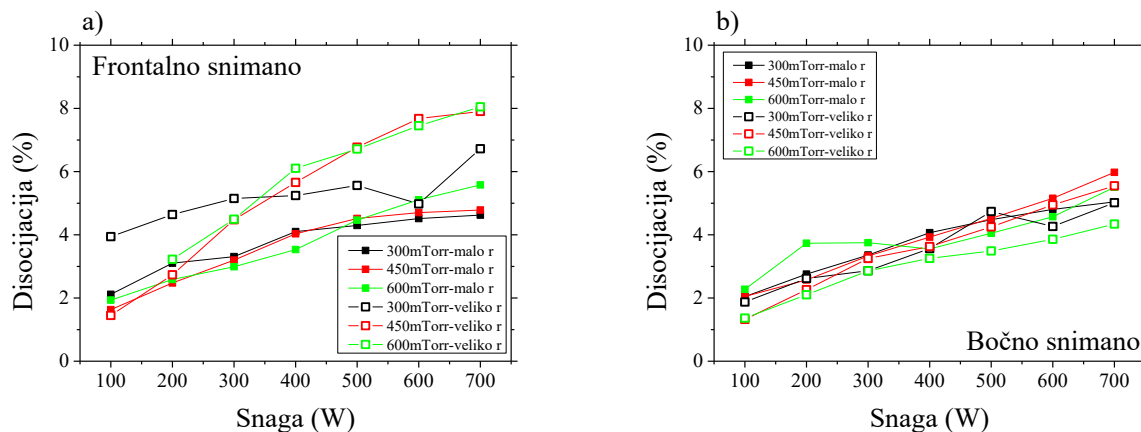

Slika 2.2.65 Poređenje stepena disocijacije O₂ molekula, koja je aktinometrijskom metodom dobijeno sa dve različite dimenzije uzemljenih elektroda iz spektara snimljenih a) frontalno i b) bočno u odnosu na napajanu elektrodu.

Poređenje stepena disocijacije za različite prečnike uzemljenih elektroda je prikazano na slici 2.2.65. Iz spektara koji su dobijeni snimanjem sa prednje strane komore su proračunati nešto veći stepeni disocijacije za pražnjenje tokom kog je korišćena uzemljena elektroda većeg poluprečnika. Iako su vrednosti bile vrlo slične na malim primenjenim snagama, stepen disocijacije će sa povećanjem snage rasti znatno sporije kada je u komori bila postavljena dodatna uzemljena elektroda. Podsetimo se da se snimanje spektara sa bočne pozicije obavlja kroz prozor na komori i kroz prorez na uzemljenoj elektrodi. Sa te pozicije će i za različitu optičku opremu biti vidljiva ista zapremina pražnjenja. S obzirom na to da su iz bočno snimanih spektara dobijene skoro identične vrednosti za različite prečnike uzemljenih elektroda, možemo da kažemo da do razlike u stepenu disocijacije koji je dobijen iz frontalno snimanih spektara, u određenoj meri, dolazi i zbog toga što je za snimanje korišćena različita oprema koja svetlost skuplja iz nešto drugačijih prostornih uglova.

2.2.5.3 Zaključak

Korišćenjem aktinometrijske metode je, za tri različita pritiska i nominalne snage pražnjenja od 100 do 700 W, izračunat stepen disocijacije molekula kiseonika i apsolutna koncentracija atoma kiseonika iz spektara dobijenih sa dve različite pozicije snimanja. Za proračun je korišćen odnos linije kiseonika na 844,6 nm i linije argona na 811,5 nm.

Koncentracije O atoma koje su dobijene iz spektara snimljenih kroz prednji prozor komore značajno su veće tokom pražnjenja sa uzemljenom elektrodom većeg poluprečnika. Sa druge strane, snimanjima kroz bočni prozor su izmerene koncentracije bile veće tokom pražnjenja sa uzemljenom elektrodom manjeg poluprečnika. Ovde je važno opet naznačiti da se aktinometrijskim merenjima

dobijaju podaci koji su usrednjeni po celom prostornom uglu korišćene merne opreme i vremenski integrisani. S obzirom na izraženu asimetriju sistema i radijalno promenljive intenzitete emisije kod ovakvog reaktora, dobijene podatke u dve različite konfiguracije treba porediti uzimajući u obzir sve parametre prilikom snimanja. Ranije je već pokazano, katalitičkom sondom, da koncentracija atoma u našem reaktoru opada sa povećanjem rastojanja od napajane elektrode [169]. Treba imati u vidu da su snimcima koji su korišćeni tokom aktinometrijskih merenja obuhvaćeni delovi plazme sa veoma različitim koncentracijama kiseonikovih atoma i molekula. Odnosno obuhvaćene su prielektrodne oblasti kako uzemljene tako i napajane elektrode, oblasti uz samu napajanu elektrodu gde je emisija vrlo intenzivna i oblasti koje su nešto dalje od napajane elektrode u kojima je emisija, pogotovo atoma, mnogo manja. Zbog toga dobijena vrednost koncentracije O atoma, ali i disocijacije, zapravo predstavlja usrednjenu vrednost iz cele oblasti iz koje je svetlost prikupljana. Postavljanjem uzemljene elektrode manjeg poluprečnika je sama efektivna zapremina reaktora smanjena. Takođe, zbog nešto drugačije opreme koja je korišćena, zavisno od toga koja je uzemljena elektroda korišćena, emisija je snimana iz nešto drugačijih prostornih uglova. Zbog toga, stepene disocijacije koji su dobijeni iz spektara snimljenih frontalno i bočno, za dve različite dimenzije uzemljenih elektroda, možemo porediti samo ako imamo u vidu i pomenute razlike u prostornim uglovima. Stepene disocijacije dobijene iz frontalno snimljenih spektara je nešto veći tokom pražnjenja bez dodatne uzemljene elektrode, dok su iz bočno snimljenih spektara izračunati vrlo slični stepeni disocijacije. Kao zaključak možemo reći da se u obe konfiguracije uzemljenih elektroda dobijaju vrlo slični stepeni disocijacije O₂ u opsegu od 1,5% do 7% koji zavise od pritiska i primenjene snage.

2.3 PRIMENE ASIMETRIČNOG PRAŽNJENJA VELIKE ZAPREMINE U TRETMANIMA TEKSTILA I SEMENA

U prethodnim poglavljima su prikazani rezultati ispitivanja hemijskog sastava plazme i opisane su neke fizičke osobine pražnjenja. Izvršena su merenja reaktivnih kiseonikovih vrsta, poput neutralnih atoma i molekula ali i njegovih pobuđenih stanja, pokazano je i da su uslovi pražnjenja relativno blagi. Upravo ovakva kombinacija fizičkih i hemijskih osobina je pogodna za tretman osetljivih uzoraka, poput semena različitih biljaka ili tekstila.

U prethodnim eksperimentima je u našoj laboratoriji već ispitivano kako izlaganje semena plazmi utiče na promenu klijavosti. U fokusu je bilo seme caričinog drveta, koje se često koristi kao model biljka. Do sad su kao radni gasovi korišćeni vazduh i argon [45], [170], [171]. Pokazano je da se u određenim uslovima i vremenima tretmana klijavost može povećati i nekoliko puta. Međutim, ukoliko je tretman neadekvatan rezultati mogu biti i znatno lošiji nego kod netretiranog semena. U ekstremnim slučajevima, ukoliko je na primer tretman predugačak, može da se desi da ne proklija ni jedno seme koje je bilo u plazmi. Takođe smo pokazali da se pozitivni efekti tretmana pojavljuju kao sinergija svih fizičkih i hemijskih osobina pražnjenja [171]. Naime, ukoliko se između plazme i tretiranog semena postavi kvarcno staklo koje sprečava UV svetlost da dođe do semena, dobiće se značajno manja maksimalna klijavost u odnosu na situaciju u kojoj je seme bilo izloženo svim efektima plazme.

U ovom poglavlju će biti prezentovani rezultati plazma tretmana semena caričinog drveta. Oni su rađeni sa ciljem ispitivanja efekta takvih tretmana na aktivnost enzima u ranim fazama klijanja. Takođe, tretirano je i seme komercijalnih vrsta kukuruza i žita kako bi se uticalo na njihovu klijavost ali i da bi se videlo da li je plazmom moguće smanjiti stepen infekcije patogenima koji se kod ovih vrsta često pojavljuju.

Caričino drvo (*paulownia tomentosa*) je biljka koja spada u grupu pozitivno fotoblastičnih. To znači da izlaganje semena svetlu utiče na proces klijanja, odnosno da ga u konkretnom slučaju stimuliše. Sam proces klijanja, u ovakvim biljkama, kontrolišu fotoreceptori koji se nazivaju fitohromi (*eng phytochrome*). Tokom razvoja, kako semena tako i mladice, u njima se stvara veliki broj reaktivnih kiseonikovih i azotovih vrsta (RONS) [172]. Pored pozitivnih efekata na biljku, ove vrste mogu da izazovu i određena oštećenja. Međutim, ćelije su tokom evolucije razvile mehanizme za odbranu od ovih neželjenih dejstava [173]. Kao primer jednog takvog jedinjenja, odnosno reaktivne kiseonikove vrste, se može navesti vodonik peroksid (H_2O_2). On može, kao signalni molekul, da aktivira određene gene ili proteine koji su važni za rast i razvoj biljke. Takođe, u procesu lignifikacije odnosno „odrvnjavanja“ biljke dovodi do ojačanja ćelijskog zida. Međutim, u velikim količinama ima potencijalno toksično dejstvo a može da dovede i do oštećenja zbog oksidativnog stresa. U ovakvim situacijama, u odbranu biljke staje upravo katalaza. Ovaj enzim je odgovoran za izbacivanje viška vodonik peroksida, ublažavanje oksidativnog stesa ali i za kontrolu ćelijskog H_2O_2 i modulaciju s njim povezanih signalnih kanala. Katalaza se nalazi u svim aerobnim organizmima u kojima utiče na dismutaciju vodonik peroksida u vodu i kiseonik [174].

Pored živih uzoraka, semena, u našoj laboratoriji se radi i na tretmanu tekstila. Jedan od glavnih motiva za pokretanje takvih eksperimenata je mogućnost da se plazma tretmanima iz standardnih procesa obrade tekstila izbaci, ili značajno smanji, upotreba hemikalija koje su, u ekološkom smislu, izuzetno štetne [90]. Pokazali smo da je moguće uticati na osobine tekstila kao što je količina vode koju mogu da apsorbuju, kvalitet i dugotrajnost bojenja i štampanja na njima a moguće je i smanjiti skupljane nakon pranja [45], [90]. Zanimljivo je da se umesto mehaničkim ili hemijskim metodama, iznošeni izgled popularnog denima (teksasa) može takođe postići plazma tretmanom. Osim estetskih promena, ovakav tretman dovodi i do određenih promena u fizičkim osobinama materijala [103]. Povećana je otpornost na kidanje ali je u izvesnoj meri smanjena

plastičnost materijala. Pokazali smo i mogućnost da se korišćenjem plazma procesa na površinu tekstila nanese nanočestice TiO_2 [1]. Ovako pripremljen materijal se pokazao kao izuzetno baktericidan, kao dobra zaštita od UV zračenja i postao je znatno otporniji na stvaranje mrlja.

U ovom poglavlju disertacije ćemo predstaviti rezultate eksperimenta u kojima je ispitivano kako plazma tretman utiče na mogućnost nanošenja mikrokapsula na površinu tekstila. Postoje razne vrste mikrokapsula koje mogu da se koriste kao repelent za insekte, da imaju kozmetičku ulogu, da dodaju vatrootpornost materijalu ili da omoguće polihromne i termohromne efekte [175]. Mi smo se skoncentrisali na kapsule koje u sebi sadrže mirisne supstance. Pored toga što mogu da imaju kozmetičku ulogu, ovakve tkanine mogu da se koriste i za aroma terapiju a mogu da imaju i anti-upalno ili umirujuće dejstvo.

2.3.1 EKSPERIMENTALNA POSTAVKA

Za tretman semena na niskom pritisku je korišćen asimetrični plazma reaktor manje zapremine, koji pomenut u glavi 2.1. Da podsetimo, on je takođe cilindrične geometrije sa aksijalno postavljenom napajanom elektrodom, ali su mu apsolutne dimenzije manje. Dugačak je 46 cm a unutrašnji prečnik mu je 37,5 cm. Manji reaktor je odabran za tretmane uzoraka zbog praktičnosti. Naime, vreme koje je potrebno za otvaranje i zatvaranje velikog reaktora iznosi i po nekoliko sati naspram svega nekoliko minuta, koliko je potrebno za reaktor manjih dimenzija. Takođe, zbog višestruko manje zapremine proces vakuumiranja sa atmosferskog do radnog pritiska se može obaviti za značajno kraće vreme. I kod manjeg reaktora je spoljašnji zid komore, napravljen od nerđajućeg čelika korišćen kao uzemljena elektroda. Napajana elektroda je napravljena od aluminijuma. Dugačka je 40 cm i ima prečnik od 1,4 cm.

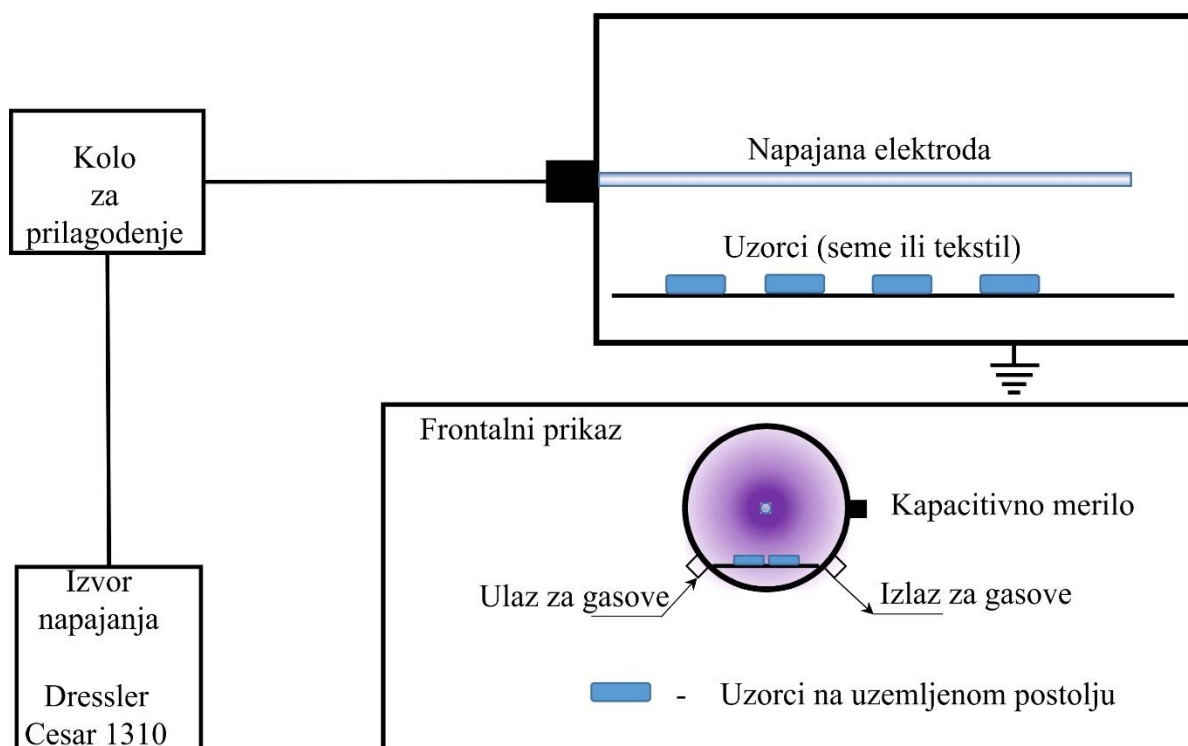

Slika 2.3.1 Eksperimentalna postavka. Cilindrični reaktor male zapremine, sa prikazanom pozicijom tretiranog semena u Petrijevim posudama

Kako bi se u komoru postavili uzorci otvaraju se vrata sa njene prednje strane, nasuprot napajanoj elektrodi. Postolje za uzorke se nalazi sa donje strane komore. Kako je u električnom kontaktu sa uzemljenim zidom reaktora, i postolje je uzemljeno. Nalazi se 13 cm ispod napajane elektrode. Zavisno od količine uzoraka tokom jednog tretmana, oni se mogu postaviti direktno ispod elektrode ili se mogu poređati u dve kolone kao što je prikazano na slici 2.3.1.

Za postizanje i održavanje niskog pritiska je korišćena ista oprema kao i za asimetrični reaktor velike zapremine. Vakuum se postiže mehaničkom pumpom, dok se kontrola pritiska obavlja podešavanjem protoka radnog gasa. Korišćen je, takođe, identičan sistem za predaju snage plazmi.

2.3.2 UTICAJ PLAZME NA AKTIVNOST ENZIMA CARIČINOG DRVETA

Klijanje caričinog drveta odvija se u tri faze. Faza imbibicije je prva, zatim sledi faza aktivnosti fitokroma, dok u poslednjoj dolazi do izbivanja i rasta klice. Optimalno vreme imbibicije iznosi tri dana. Prethodna istraživanja [176], [177] su pokazala da je za inicijaciju faze aktivnosti fitokroma dovoljno da seme bude 5 minuta izloženo svetlosti na talasnoj dužini od 660 nm. Ova faza traje između 48 i 72 h. Procesi koji slede, uključujući izbivanje klice iz semena, traju nekoliko dana, posle čega može da se kaže da je klijanje biljke završeno.

Tretman semena caričinog drveta je obavljen na pritisecima od 200 i 600 mTorr. Njima su odgovarali protoci od 80 i 435 sccm kiseonika koji korišćen kao radni gas. Minimalni pritisak koji je bilo moguće postići je iznosio 20 mTorr, što znači da su u komori u izvesnoj meri bile prisutne i nečistoće, odnosno vazduh. Svi tretmani su rađeni na nominalnoj snazi generatora od 100 W. Uzorci su bili u Petri posudi koja je postavljena na uzemljeno postolje, što znači da su se praktično nalazili u prielektrodnoj oblasti uzemljene elektrode. Za njihovo postavljenje su, tokom svakog tretmana, korišćene posude prečnika 6 cm u kojima se nalazilo po 100 semena. Vremena tretmana, za svaki pritisak, su iznosila 1, 5, 10 i 20 min.

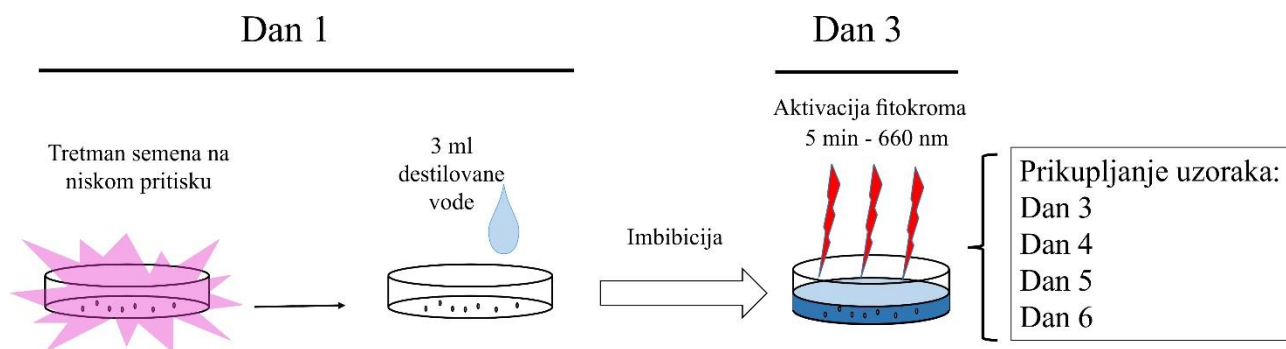

Slika 2.3.2 Eksperimentalna procedura. Nakon tretmana, svakoj Petri posudi sa 100 semena se doda 3 ml vode. Imbibicija traje 3 dana u potpunom mraku posle čega se seme osvetljava (5 min, 660 nm). Uzorci su analizirani sledećih 4 dana na svakih 24 h

Cilj ovog eksperimenta je bio da se uvidi kako će tretman semena plazmom na niskom pritisku uticati na aktivnost katalaze u ranim fazama klijanja. Korišćeno je seme caričinog drveta (*P. tomentosa* Steud.) koje je prikupljeno tokom 2015.-e u bašti Instituta za biološka istraživanja „Siniša Stanković“. Nakon tretmana je u svaku posudu sipano po 3 ml vode, kako bi seme moglo da prođe kroz fazu imbibicije, odnosno prikupljanja vode. Uzorci su nakon toga ostavljeni 3 dana u mraku na temperaturi od $25 \pm 2^\circ\text{C}$. Kako bi se aktivirali fitohromi i inicirao proces klijanja, seme je osvetljeno crvenom svetlošću talasne dužine 660 nm, impulsom čije je trajanje 5 minuta. U tu svrhu su korišćene

Asimetrično kapacitivno spregnuto pražnjenje velike zapremine

Philips TL 20/15 fluorescentne cevi sa Röhms & Haas plastičnim filterima. Tokom sledeća 3 dana su uzorci za analizu uzimani na svakih 24 h. Da bi se izbeglo ponovno osvetljavanje uzoraka, tokom rada sa njima, korišćeno je slabo svetlo zelene boje. Ova eksperimentalna procedura je ilustrovana na slici 2.3.2.

Tretmani su rađeni u našoj laboratoriji, dok su ostale analize izvršene u institutu „Siniša Stanković“. Statistička analiza je rađena pomoću Stargraphics softverskog paketa. Razlike među tretmanima su testirane korišćenjem standardne analize varijanse. Srednje vrednosti su razdvojene korišćenjem Fišerovog LSD testa (*eng* Least Significant Difference) uz uslov da je $p > 0,05$. Za rezultate za koje je važno da je $p \leq 0,05$ smo smatrali da su identični i na graficima koji slede su takve vrednosti obeležene istim slovom.

Na odabranim parametrima pražnjenja i pritiscima, od 200 i 600 mTorr, glavna razlika u uslovima tretmana se svodi na broj čestica koje dolaze do površine semena. Naravno, biće ih više na većem pritisku. Već je postulirano [170], [171] da pozitivni efekti na rast i klijavost semena potiču od depozicije aktivnih molekula i radikala na seme, najviše preko signalnih procesa u ćeliji. Zbog toga postoji potreba da se pronade veza između plazma hemije tokom tretmana, kada ove aktivne vrste nastaju, i procesa koje one izazivaju unutar ćelija semena.

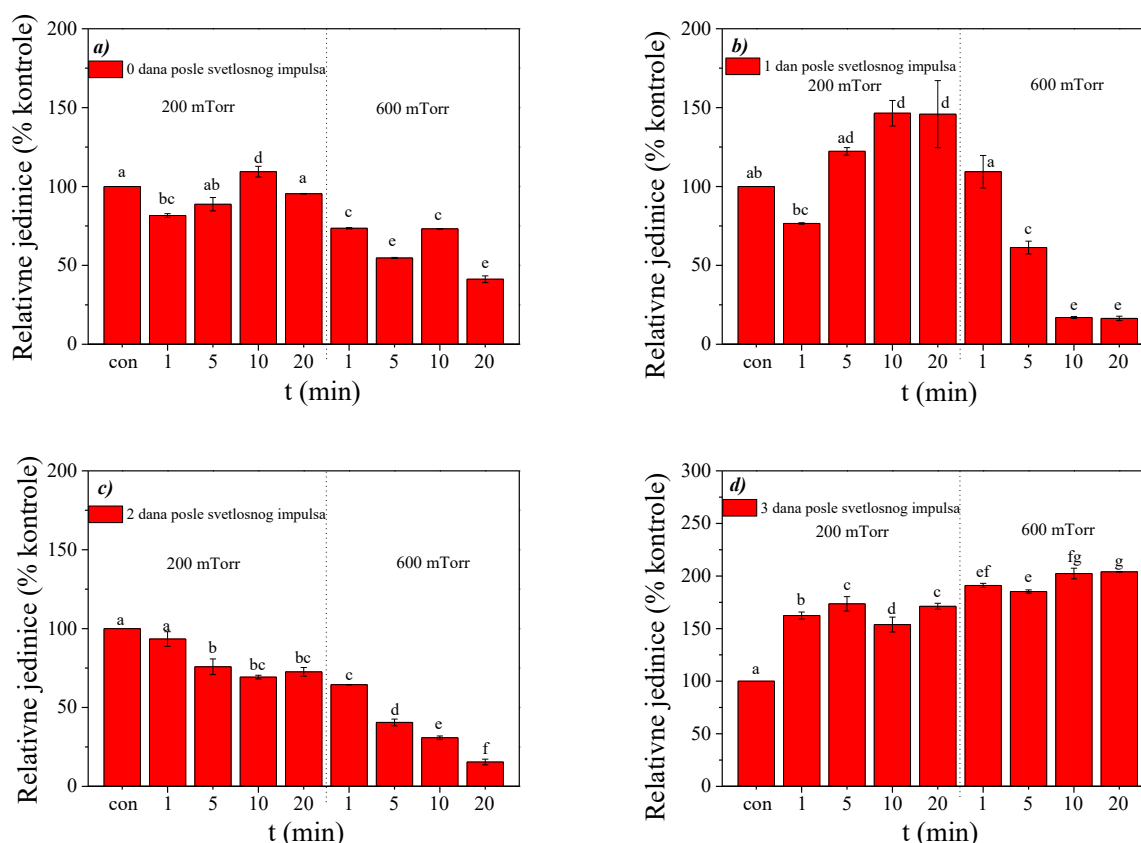

Slika 2.3.3 Aktivnost katalaze u semenu caričinog drveta a) odmah nakon osvetljavanja crvenim impulsom, b) jedan, c) dva i d) tri dana nakon toga. Vrednosti su dobijene iz tri ponovljena eksperimenta sa naznačenom greškom. Rezultati čije su vrednosti po Fišerovom LSD testu takve da važi da je $p \leq 0,05$ su predstavljene istim slovom. [109]

Rezultati merenja aktivnosti katalaze u danima nakon osvetljavanja semena petominutnim crvenim impulsom su prikazani na slici 2.3.3. Važno je napomenuti da kontrolna grupa semena, na

koju su rezultati i normirani, prolazi istu proceduru kao i sva ostala semena osim izlaganja plazmi. To znači da im je faza imbibicije, u odsustvu svetla, takođe trajala 3 dana nakon čega su i ona osvetljena i potom analizirana na svaka 24 časa. Ovde je potrebno naglasiti da je katalaza samo jedan od enzima koji su važni u ranim fazama klijanja i da se njegova aktivnost ne može direktno povezati sa efikasnošću klijanja. U danu u kome je izvršeno osvetljavanje semena, prikazano na slici 2.3.3 a), plazma tretman na pritisku od 200 mTorr nije doveo do značajne promene u aktivnosti. Semena koja su tretirana 1 min su imala pad aktivnosti od oko 20 %, dok je tretman od 10 min uzrokovao blagi porast u odnosu na kontrolnu grupu. Za druga dva vremena tretmana, razlike u odnosu na kontrolu nisu dovoljno značajne. Sa druge strane na pritisku od 600 mTorr je pad uočljiv za sva vremena tretmana a najintenzivniji je, oko 60 %, za vreme od 20 min. Prvog dana nakon osvetljavanja, slika 2.3.3 b), na pritisku od 200 mTorr aktivnost enzima raste sa vremenom tretmana. Na 600 mTorr je situacija potpuno obrnuta, odnosno aktivnost je manja u semenu koje je duže tretirano, pa za vremena od 10 i 20 min, ona iznosi manje od petine aktivnosti kontrolnih uzoraka. Drugog dana nakon osvetljavanja semena je u svim uzorcima izmerena manja aktivnost katalaze u odnosu na kontrolu, slika 2.3.3 c). Primetno je opadanje sa vremenom tretmana ali i sa pritiskom na kome je tretman izvršen pa je najmanja aktivnost izmerena u semenima koja su na pritisku od 600 mTorr provela 20 min u pražnjenju i ona iznosi svega 15 % aktivnosti kontrolnog uzorka. Međutim, četvrtog dana merenja, odnosno tri dana nakon crvenog impulsa situacija postaje značajno drugačija i praktično potpuno suprotna. Za sve uslove tretmana je aktivnost katalaze bila između 1,5 i 2 puta veća od one u kontrolnim uzorcima. Može da se primeti trend povećane aktivnosti sa produžavanjem vremena tretmana ali i sa povećanjem pritiska na kome je on rađen, pa je maksimum dobijen za tretman od 20 min na pritisku od 600 mTorr.

Nakon pomenutih faza klijanja, nastupa sledeća faza u razvoju mladice odnosno faza takozvanog platoa. Tokom nje dolazi do ponovnog pokretanja svih onih mehanizama u metabolizmu koji su aktivni tokom života biljke a nisu aktivni u semenu. Pre ove faze, u neaktivnom semenu i semenu koje tek počinje da klija, ne odvijaju se procesi poput ćelijskog disanja, popravke DNK lanaca, uklanjanja stare i pravljenja nove mRNK, ili deobe ćelija. U fazi platoa dolazi do njihove reaktivacije ali tada dolazi i do aktivacije antioksidativnih enzima [178], [179]. Upravo povećanje aktivnosti katalaze, koja pripada ovoj grupi enzima, može da bude indikator povišene količine reaktivnih kiseonikovih jedinjenja jer ovaj enzim zapravo predstavlja odgovor biljke na povišen oksidativni stres [180]. Takođe bi aktivnost ovog enzima mogla da se koristi kao parametar opšteg stanja biljke [181]. Za fazu klijanja se, u velikoj većini biljaka, može reći da je završena onog trenutka kada klica probije strukture koje okružuju embrion. Tada dolazi do pojačane aktivnosti katalaze, što smo mi i izmerili 3.-eg dana nakon osvetljavanja.

Asimetrično kapacitivno spregnuto pražnjenje velike zapremine

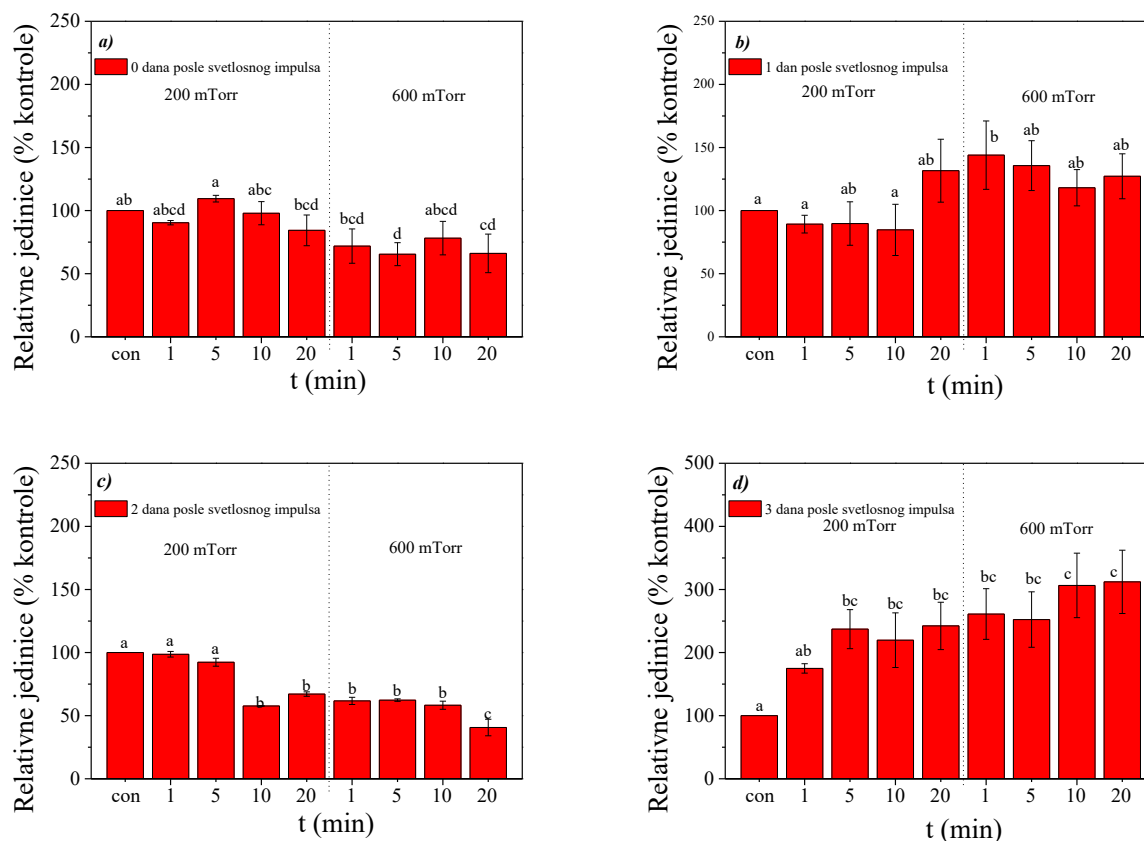

Slika 2.3.4 Sadržaj katalaze dobijen imunoblot analizom, denzitometričkom metodom, u semenu caričinog drveta a) odmah nakon osvetljavanja crvenim impulsom, b) jedan, c) dva i d) tri dana nakon toga. Podaci su normalizovani na kontrolni uzorak i prikazani su sa standardnom greškom. Tretmani koji su označeni istim slovom, po Fišerovom LSD testu, nemaju značajno različite vrednosti ($p \leq 0,05$). [109]

Imunoblot analiza je pokazala da je u našim semenima prisutna samo jedna izoforma katalaze, od 50 kDa. Na slici 2.3.4 je prikazan sadržaj enzima koji je izmeren za iste parametre tretmana i u isto vreme kada je merena i njegova aktivnost. U danu kada je izvršeno osvetljavanje uzoraka, među semenima koja su tretirana na pritisku od 200 mTorr, za skoro sva vremena tretmana, je dobijena vrlo slična količina katalaze. Nešto manji sadržaj, oko 85 % u odnosu na kontrolu, je izmeren u semenima koja su tretirana 20 min. Na većem pritisku su dobijene nešto niže vrednosti i bile su do 35 % manje od kontrolnog uzorka, slika 2.3.4 a). Dan nakon svetlosnog impulsa su za niži pritisak takođe izmerene vrednosti koje se, osim za najduže vreme tretmana, ne razlikuju značajno u odnosu na kontrolu. Međutim, kao što se može videti na slici 2.3.4 b), za semena koja su tretirana na 600 mTorr su dobijene vrednosti koje su bile i do 44 % više od onih u kontrolnom uzorku. Dva dana nakon aktivacije fitokroma je sadržaj katalaze za skoro sve uslove tretmana bio znatno niži, i do 60 %, nego u netretiranim semenima. Ipak, za tretmane na pritisku od 200 mTorr i za vremena od 1 i 5 min nije bilo značajne razlike u odnosu na kontrolne uzorke. Na slici 2.3.4 d) može da se vidi da je trećeg dana nakon osvetljavanja uzorka došlo do velikog porasta u sadržaju enzima u semenu. Uz male oscilacije, sadržaj katalaze je bio veći u semenima koja su duže tretirana ili ako je tretman rađen na višem pritisku. U semenima koja su tretirana 10 i 20 min na 600 mTorr, je bilo preko tri puta više katalaze nego u netretiranim semenima. Ovo se u velikoj meri slaže sa aktivnošću katalaze koja je prikazana na slici 2.3.3 d) gde je takođe primetan značajan porast trećeg dana nakon osvetljavanja semena. Treba imati u vidu da se imunoblot analizom dobijaju podaci vezani sa sintezu podjedinica enzima, koji nisu direktno vezani za njegovu aktivnost.

2.3.3 TRETMAN KOMERCIJALNIH SEMENA U CILJU POVEĆANJA KLIJAVOSTI I SMANJENJA ZARAZE

Pored semena caričinog drveta, koje je detaljno analizirano [109], [170], [171], u našoj laboratoriji je urađen čitav niz preliminarnih tretmana semena većeg broja biljaka. Rezultati koje ćemo prezentovati predstavljaju samo deo ovih eksperimenata koji će se u budućnosti nastaviti. Naime, u saradnji sa kolegama iz Belorusije je tretirano seme prolećne pšenice i kukuruza. Tokom tretmana je u komori bilo 60 semena. Petrijeve posude su, i tokom ovih tretmana, bile postavljene ispod napajane elektrode, na postolju za uzorke. U jednu Petrijevu posudu je bilo postavljeno po 20 semena pšenice ili 10 semena kukuruza, koji je znatno veći. Pšenica je tretirana na pritisku od 500 mTorr sa nominalnim snagama od 50 i 100 W, dok je seme kukuruza tretirano na pritisku od 300 mTorr sa primenjenom snagom od 200 W. Kako bi se što bolje procenio efekat dužine tretmana na semena, vremena tretiranja su izabrana tako da pokriju širok opseg. Konkretno: 1 min, 5 min, 7 min, 10 min i 20 min. Tokom ovih eksperimenata je kao radni gas korišćen vazduh.

Na slici 2.3.5 je prikazan efekat tretmana semena pšenice na njegovu klijavost. Važno je imati na umu da je u pitanju komercijalno seme čija je polazna klijavost preko 90 %. Pozitivni efekti plazme na seme su vidljivi samo za kraća vremena tretmana. Maksimalno povećanje klijavosti u odnosu na kontrolni uzorak je dobijeno za vreme od 7 min na snazi od 50 W i za vreme od 5 min na snazi od 100 W. U oba slučaja je ono iznosilo oko 5 %. Sa daljim povećanjem vremena tretmana dolazi do oštećenja semena koje se ispoljava i kroz pad klijavosti. S obzirom da porast temperature nije zabeležen, pretpostavka je da oštećenje izaziva dugotrajno bombardovanje površine jonima i aktivnim vrstama iz plazme. Najintenzivnija negativna promena je nastala upravo na snazi od 100 W i posle tretmana od 20 min. U tim uslovima je koncentracija aktivnih čestica najveća, a kao posledicu njihovog dugotrajnog delovanja na površinu semena imamo pad klijavosti na svega 72%.

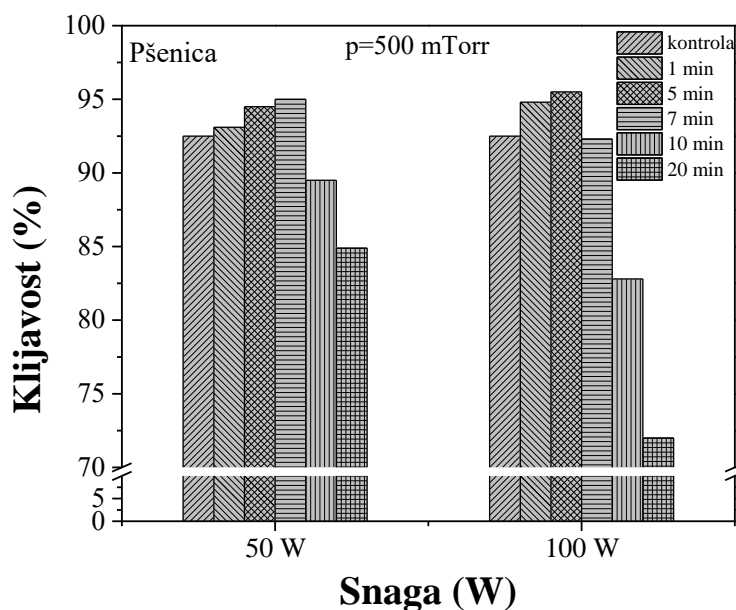

Slika 2.3.5 Klijavost semena pšenice nakon tretmana u vazdušnoj plazmi na pritisku od 500 mTorr. Tretmani su rađeni na nominalnim snagama od 50 i 100 W i trajali su između 1 i 20 min. [2]

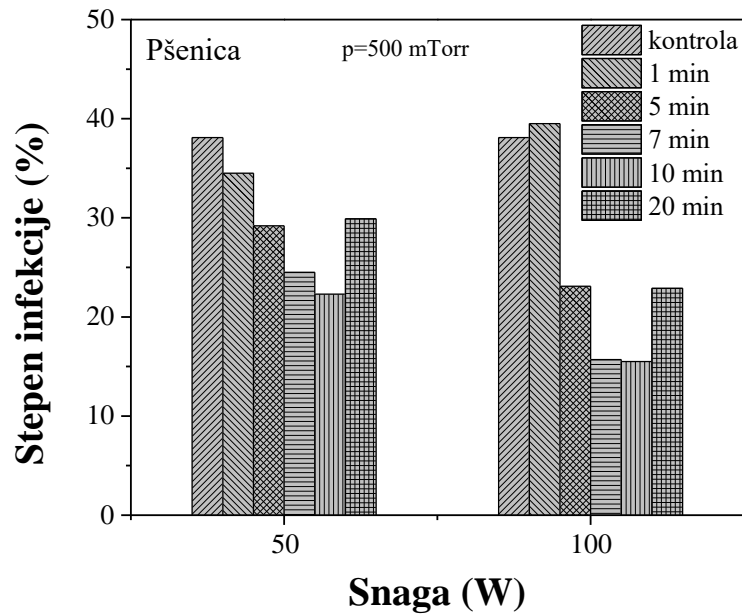

Slika 2.3.6 Stepen infekcije semena pšenice, izražen u procentima, nakon tretmana u vazdušnoj plazmi na pritisku od 500 mTorr. Tretmani su rađeni na nominalnim snagama od 50 i 100 W i trajali su između 1 i 20 min. [2]

U uvodnom delu disertacije je rečeno da zbog uslova u kojima se komercijalno seme čuva, često može da dođe do infekcija različitim vrstama gljivica i bakterija. Seme pšenice, kojoj smo imali pristup, je bilo zaraženo gljivicama iz rodova *Mucor* i *Fusarium*. Testirano je da li bi identični uslovi tretmana mogli da pomognu u uklanjanju patogena a rezultati su prikazani na slici 2.3.6. Na manjoj nominalnoj snazi od 100 W je, sve do 20 min, duži tretman dovodio do manjeg stepena infekcije. Najveće smanjenje količine patogena, pri ovoj snazi, je postignuto za vreme tretmana od 10 min gde je stepen infekcije je opao za više od 50%. Nakon dužeg tretmana, odnosno 20 min, stepen infekcije semena se povećao, ali je i dalje bio manji od kontrolnog uzorka. Poznato je da plazma tretman dovodi do uklanjanja materijala (*eng. sputtering, etching*) sa tretirane površine. Sa povećanjem vremena tretmana omotač semena može da postane previše oštećen i samim tim seme je podložnije delovanju patogena.

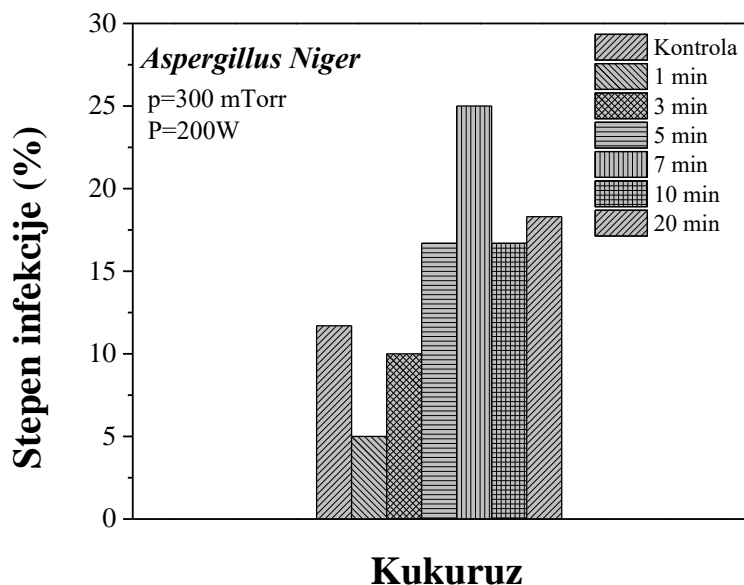

Slika 2.3.7 Tretman sa ciljem smanjenja uklanjanja bakterije *Aspergillus Niger*. Pritisak tokom tretmana je bio 300 mTorr a primenjena nominalna snaga 200 W. Vremena tretmana su bila između 1 i 20 min [2].

U našim eksperimentima, tretmani vazdušnom plazmom nisu dali pozitivan efekat na klijavost kukuruza i ni za jedan set uslova nisu dali klijavost koja bila veća od kontrolne. Međutim, situacija je nešto drugačija što se tiče tretmana sa ciljem uklanjanja patogena. Seme kukuruza koje je tretirano u našim eksperimentima je bilo zaraženo gljivicom *Aspergillus Niger*. Ova gljivica je jedno vreme bila u žiži srpske javnosti kao patogen koji dovodi do stvaranja vrlo štetnog aflatoksina. Kao što je prikazano na slici 2.3.7, najviše patogena je uklonjeno tokom tretmana od samo jednog minuta. Tom prilikom je stepen infekcije opao za više od 50 %. Već nakon tretmana od 3 minuta su rezultati bili značajno lošiji. Iako je stepen infekcije bio manji nego u kontrolnom uzorku, bio je skoro duplo veći nego kod semena koja su tretirana samo jedan minut. Nakon svih ostalih, dužih, tretmana je stepen infekcije, zbog oštećenja površine semena, bio znatno veći nego kod kontrolnih uzoraka.

2.3.4 TRETMAN PAMUČNE TKANINE SA CILJEM NANOŠENJA MIKROKAPSULA

U ovim tretmanima je korišćena tkanina koja je napravljena od 100 % pamuka, hemijski izbeljenog. Kapsule koje su korišćene, (AERO, Slovenija), imale su mirisnu notu jagode.

Kako bi se pritisak tokom tretmana održao na konstantnoj vrednosti od 200 mTorr, podešavan je protok kiseonika ili azota koji su korišćeni kao radni gasovi. Nominalna snaga je bila 100 W a vreme tretiranja svih uzoraka je iznosilo 5 min.

S obzirom da je odavno postulirano, a o tome je i u uvodu bilo reči, da je glavni deo promena u mehaničkim osobinama tekstila uzrokovan promenama u površinskoj morfologiji tkanine, napravljeni su snimci površine pre tretmana i nakon tretiranja kiseoničnom ili azotnom plazmom. Fotografije sa slike 2.3.8 su napravljene elektronskim mikroskopom, JEOL SEM type JSM-6060LV. Pre snimanja je na uzorke bilo potrebno naneti tanak sloj zlata. Napon za ubrzavanje elektrona je bio podešen na 10 kV.

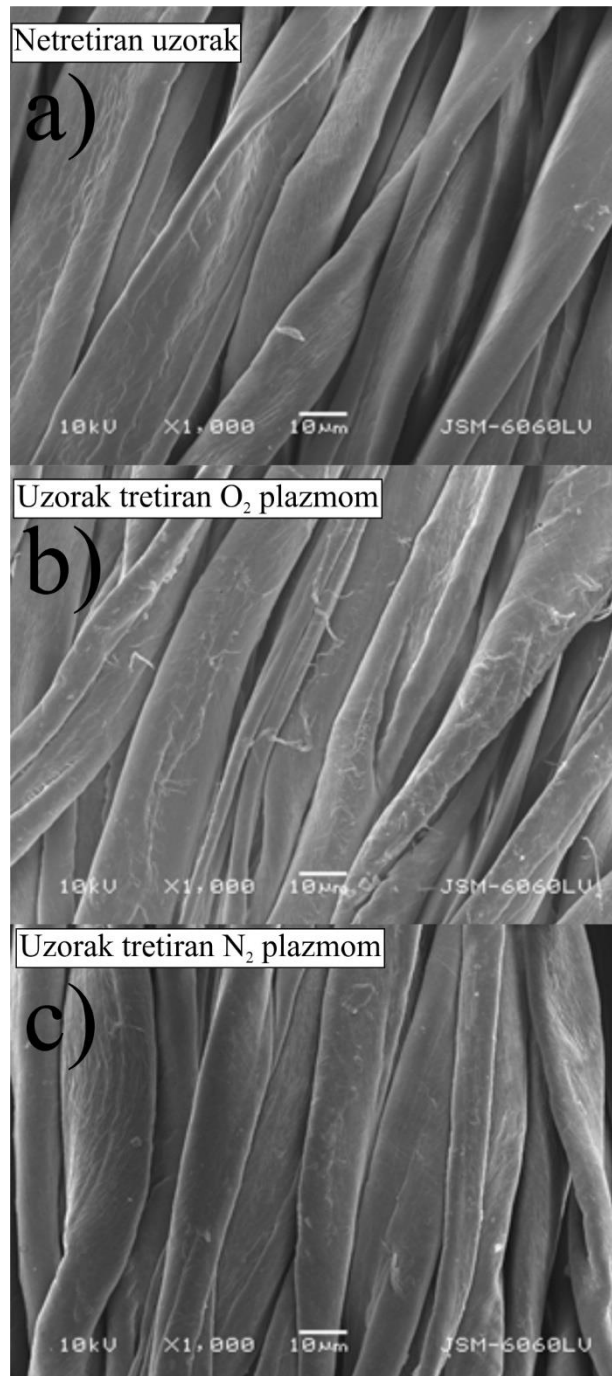

Slika 2.3.8 Morfologija površine uzoraka koji a) nisu tretirani i koji su tretirani plazmi u b) kiseoniku i c) azotu. Slike su dobijene elektronskim mikroskopom (SEM). Uslovi tretmana: 200 mTorr, 100 W, 5 min. Radni gas: azot ili kiseonik.

Uočljive morfološke promene se jasno vide samo na uzorku koji je bio izložen kiseoničnoj plazmi. Na njemu je vidljivo da, usled bombardovanja površine česticama iz pražnjenja, iz glavnog vlakna izlaze pojedinačni filamenti celuloze. Obično kod uzoraka kod kojih su ovakve promene jasno vidljive, one dovode do pogoršanja njihovih mehaničkih osobina [182]. To se najčešće dovodi u vezu sa gubitkom mase uzorka tokom procesa nagrizanja njegove površine. U našim eksperimentima takve promene nisu primećene, što se može videti iz tabele 2.3.1.

Tabela 2.3.1 Mehaničke osobine tretiranih i netretiranih uzoraka. Prikazana je sila kojom je potrebno delovati na uzorak da bi došlo do cepanja (N), maksimalno izduženje pre nego što dođe do cepanja (mm) i otpornost na savijanje (mg cm).

Uzorak	Sila cepanja (N)	Maksimalno izduženje (mm)	Otpornost na savijanje (mg cm)
Netretiran	357 ± 13	14.9 ± 1.5	266.0 ± 19
Tretman u O ₂	403.2 ± 9.2	16.39 ± 0.09	223.0 ± 3.7
Tretman u N ₂	368 ± 26	15.7 ± 0.7	196.0 ± 9.1

Iz prve kolone tabele 2.3.1 se vidi da je najveća sila potrebna da bi se pocepao uzorak koji je tretiran u kiseoničnoj plazmi. Između netretiranog uzorka i uzoraka koji su tretirani u azotnoj plazmi nema značajne razlike u sili koja je potrebna da bi došlo do cepanja. Ono što je zanimljivo je da je kod oba tretirana uzorka došlo do smanjenja otpornosti na savijanje, odnosno uzorci su praktično postali mekši.

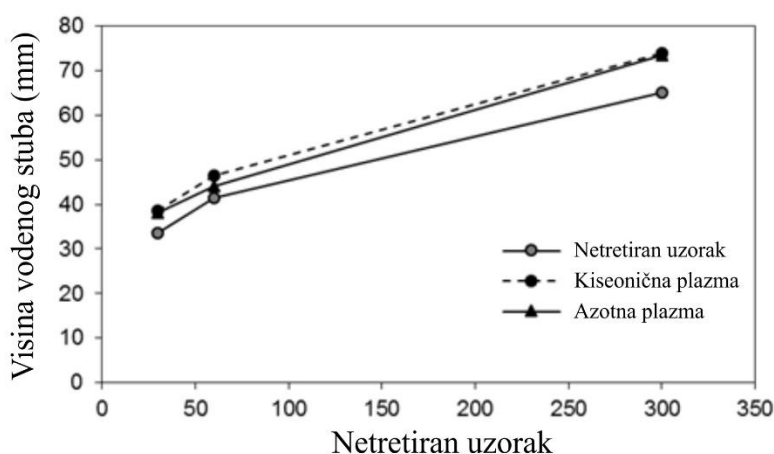

Slika 2.3.9 Sposobnost uzorka da primi vodu je testirana kroz visinu vodenog stuba u vertikalnoj tkanini čiji se jedan kraj nalazi u vodi. Merenja su rađena 30, 60 i 300 sekundi nakon dodirivanja površine vode. Viši stub znači da je uzorak hidrofilniji

Mogućnost uzorka da upije vodu je testirana tako što je tkanina držana vertikalno iznad vode a jedan njen kraj je bio potopljen. Nakon 30, 60 i 300 sekundi je merena visina vodenog stuba u uzorku a rezultati su predstavljeni na slici 2.3.9. Uzorak koji je primio više vode će imati viši vodeni stub, odnosno za njega može da se kaže da ima veću hidrofilnost. U našim eksperimentima su oba tretirana uzorka, i u kiseoniku i u azotu, apsorbovala veću količinu vode od netretiranog uzorka. Ova razlika je najuočljivija 300 s nakon potapanja, kada je visina vodenog stuba kod tretiranih uzoraka, u oba radna gasa, bila oko 1 cm veća nego kod netretiranog.

Asimetrično kapacitivno spregnuto pražnjenje velike zapremine

Na slici 2.3.10 je prikazana morfologija uzoraka nakon što je izvršeno nanošenje mirisnih mikrokapsula. Slike su napravljene elektronskim mikroskopom pod istim uslovima prikazanim na slici 2.3.7. Broj mikrokapsula je vidljivo manji na netretiranom uzorku, dok se samo posmatranjem slike ne može napraviti razlika između uzoraka koji su tretirani u kiseoniku ili azotu.

Kako bi se dodatno procenila uspešnost tretmana, odnosno kako bi se procenilo da li im je miris nanet i koliko dugo kapsule opstaju na tkanini, upotrebljen je standardizovan Luisov test (*eng* Lewis) [183], [184]. U prvom koraku se uzorci ostave sat vremena da se suše kako bi se stabilizovalo isparavanje mirisa. Oni se zatim iznose, pred panel od 30 sudija, u prostoriju za procenu. Tkanina se zatim postavlja na tvrdi podlogu tako da sudija može noktom na njoj da napravi zarez u obliku slova „X“. Na ovaj način će se neke od kapsula polomiti i počće da ispuštaju miris. Sudije imaju najviše 15 min da ocene da li je miris jak, srednji, slab ili ga uopšte nema i da svoje zapažanje unesu u tabelu. Za finalnu ocenu uzorka se uzima ona koju je dalo najviše sudija a ukupni rezultat je prikazan u tabeli 2.3.2.

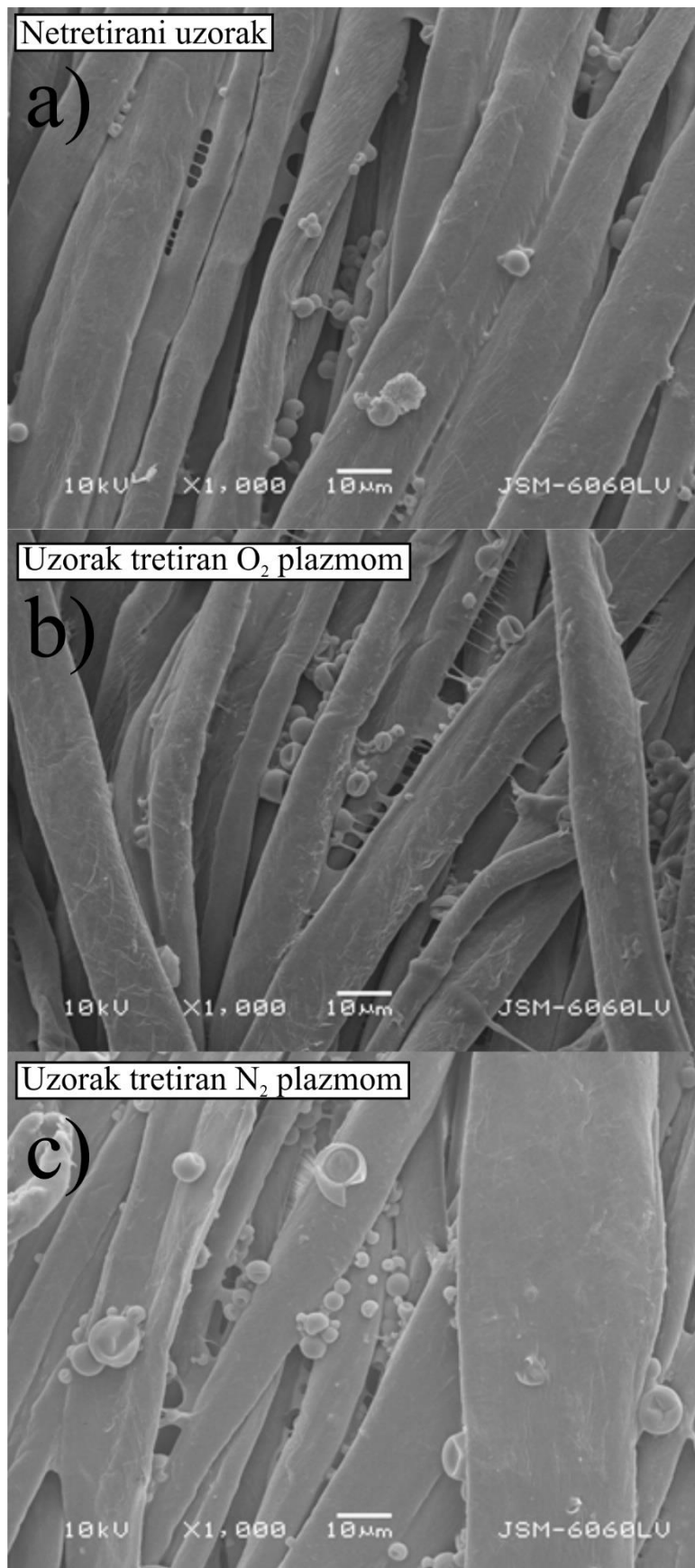

Slika 2.3.10 Slike uzoraka dobijene elektronskim mikroskopom (SEM) nakon nanošenja kapsula na a) netretiranu površinu i površinu koja je tretirana plazmom u b) kiseoniku i c) azotu. Uslovi tretmana: 200 mTorr, 100 W, 5 min.

Asimetrično kapacitivno spregnuto pražnjenje velike zapremine

Tabela 2.3.2 Intenzitet mirisa uzoraka na koje su nanete mirisne mikrokapsule po oceni panela od 30 sudija. Miris je ocenjivan nakon 1, 5 i 10 ciklusa pranja.

Uzorak	Broj pranja	Intenzitet mirisa			
		Jak	Srednji	Slab	Odsutan
Kontrolni (bez nanesenih kapsula)					+
Kontrolni	0	+			
O ₂ Plazma		+			
N ₂ Plazma		+			
Kontrolni	1		+		
O ₂ Plazma			+		
N ₂ Plazma		+			
Kontrolni	5			+	
O ₂ Plazma				+	
N ₂ Plazma		+			
Kontrolni	10				+
O ₂ Plazma					+
N ₂ Plazma			+		

Iako bi se iz prikazanih rezultata i fotografija elektronskim mikroskopom moglo očekivati da će najintenzivniji i najpostojaniji miris imati uzorci koji su tretirani kiseonikom, panel sudija se ipak odlučio za uzorke koji su pre nanošenja mikrokapsula bili tretirani azotnom plazmom. Već posle prvog ciklusa pranja su kontrolni uzorci i uzorci koji su tretirani u kiseoniku imali miris koji je ocenjen kao srednji. Nakon petog ciklusa je njihov miris ocenjen kao slab, dok je posle desetog pranja ocenjeno da mirisa više uopšte nema. Sa druge strane, uzorci koji su tretirani u azotnoj plazmi su i nakon petog pranja imali jak miris dok je posle desetog pranja njihov miris ocenjen kao srednji. Tretman azotom može da poveća stvaranje pozitivno naelektrisanih funkcionalnih grupa na površini uzoraka. Kao posledica, usled elektrostatičke privlačne veze, pojačana je apsorpcija negativno naelektrisanog akrilnog veziva, što na kraju rezultuje i povećanom količinom mikrokapsula u tekstilu odnosno dugotrajnijim i postojanijim mirisom.

2.3.5 ZAKLJUČAK

U ovoj glavi su predstavljeni rezultati tretmana termalno osetljivih uzoraka. Tretirano je seme modelne biljke (caričinog drveta), komercijalno seme (pšenica i kukuruz) i uzorci od beljenog pamuka.

Seme caričinog drveta je tretirano sa ciljem ispitivanja efekta plazma tretmana na aktivnost katalaze. Aktivnost ovog enzima je merena, nakon iniciranja klijanja svetlosnim impulsom, na svaka 24 h. U prva dva dana je aktivnost bila nešto veća u semenima koja su tretirana na niskom pritisku dok se u ostalim semenima ili nije bitno razlikovala u odnosu na kontrolni uzorak ili je bila nešto niža. Trećeg dana nakon osvetljavanja semena se situacija značajno promenila. Aktivnost enzima je, u odnosu na kontrolne uzorke, bila i do dva puta veća. Duže vreme tretmana ali i veći pritisak na kome je on rađen su doveli do veće aktivnosti. S obzirom na to da se aktivnost katalaze u biljci može koristiti i kao parametar kojim se meri njena vitalnost, pogotovo u ranim fazama rasta, kao i da će katalaza biti aktivnija u periodima oksidativnog stresa koji se, pored ostalog, takođe događa u fazi intenzivnog rasta, možemo da zaključimo da je po pitanju aktivnosti ovog enzima tretman bio uspešan. Od uslova koji su primenjeni, najbolji rezultat je dobijen u semenima koja su na pritisku od 600 mTorr u plazmi provela 20 min. Pored aktivnosti je merena i količina katalaze. Ove dve veličine nisu u direktnoj vezi ali, očekivano, među njima postoji određena korelacija. Količina enzima je takođe značajno skočila trećeg dana nakon osvetljavanja a najviše ga je bilo, i do tri puta više od kontrolnog uzorka, u semenima koja su tretirana 20 min na pritisku od 600 mTorr.

Komercijalno seme kukuruza i prolećne pšenice je tretirano sa ciljem menjanja klijavosti i uklanjanja patogena, odnosno smanjenja stepena infekcije. Iako je u pitanju seme sa visokom polaznom klijavošću, plazma tretmanima ju je moguće dodatno podići. Idealni uslovi tretmana, od onih koji su testirani, se postižu na nominalnoj snazi od 100 W tretiranjem semena u trajanju od 5 min. Duži tretmani oštećuju seme što dovodi do smanjenja klijavosti, čak i ispod vrednosti netretiranih semena. Najviše patogena je sa pšenice uklonjeno nakon tretmana od 10 minuta na nominalnoj snazi od 100 W. Kod dostupnog semena kukuruza nismo našli uslove koji dovode do povećanja klijavosti dok je stepen infekcije smanjen nakon tretmana od jednog i tri minuta. Iz ovoga je jasno da neravnotežna plazma na niskom pritisku može da utiče na klijavost, metabolizam biljke i stepen infekcije. Međutim ne mogu isti uslovi pražnjenja da se primene na različita semena. Takođe, isti uslovi neće biti jednako uspešni pri promeni klijavosti ili uklanjanju patogena.

Tretman tkanine je rađen kako bi se na nju nanele mirisne mikrokapsule. Kao radni gas su korišćeni azot ili kiseonik. Fizičke osobine materijala su se značajnije popravile nakon tretmana u azotu. Postao je otporniji na cepanje i, kada na njega deluje sila, više se izdužuje pre nego što dođe do prekida materijala. I jedan i drugi gas su nakon tretmana učinili tkaninu mekšom, odnosno savitljivijom. Procenu o dugotrajnosti i intenzitetu mirisa nakon tretmana je, principom većine, doneo panel od 30 sudija. Zaključili su da se mikrokapsule, odnosno njihov miris, na tkanini duže zadržava nakon tretmana azotnom plazmom. Takođe, miris je i nakon samo jednog ciklusa pranja već bio intenzivniji na uzorcima koji su tretirani u azotu.

2.4 ZAKLJUČAK

Druga glava disertacije je bila posvećena detaljnoj karakterizaciji pražnjenja u asimetričnom reaktoru velike zapremine ali i mogućim primenama ovakvog sistema u tretmanima bioloških uzoraka i tkanina. Sve dijagnostičke metode su primenjene u dve različite konfiguracije uzemljenih elektroda. U jednoj geometriji je kao uzemljena elektroda korišćen sam zid komore. U drugoj je korišćena dodatna uzemljena elektroda, čiji je poluprečnik odabran tako da se otvor za uzorkovanje masenog

spektrometra nalazi praktično na njenoj površini. Na taj način se uzemljena elektroda i otvor za uzorkovanje masenog spektrometra nalaze na istoj udaljenosti od napajane elektrode, odnosno omogućeno je merenje na samoj površini uzemljene elektrode. Dodatno je urađena i simulacija protoka gasova kroz reaktor, kako bi se procenilo da li postavljanjem uzemljene elektrode manjeg poluprečnika dolazi do promene u toku gasova koja bi mogla značajno da utiče na osobine plazme.

Simulacijom je ustanovljeno da će postavljanjem dodatne uzemljene elektrode jedan deo gasova, nešto većom brzinom, u prostoru između dve uzemljene elektrode da se kreće direktno između mesta na kojima se vrši dovod gasova i mesta na kome se vrši njihovo ispumpavanje. Međutim, najveći deo gasova će ipak da se kreće kroz prostor između uzemljene i napajane elektrode. Time smo pokazali da razlike u rezultatima koji su dobijeni tokom merenja sa dve različite uzemljene elektrode ne potiču od načina na koji se gasovi kreću kroz komoru već su uzrokovane faktorima kao što su razdaljina između uzemljene i napajane elektrode i odnosom njihovih površina. Tokom merenja masenim spektrometrom, dodatna razlika postoji i zbog toga što se u jednom slučaju otvor za uzorkovanje nalazi u aktivnom delu pražnjenja, na okvirno pola rastojanja između napajane i uzemljene elektrode, dok se u drugom slučaju nalazi na samoj površini elektrode koja je uzemljena odnosno praktično na zidu komore.

Derivativnim sondama je pokazano da smanjivanjem uzemljene elektrode dolazi do povećanja kapacitivnosti reaktora sa 15,7 pF na 50 pF. Vremenski signali su bili pravilniji, izgledali su skoro kao pravilne sinusoidne, kada nije bila korišćena dodatna uzemljena elektroda. Njenim ubacivanjem je došlo do povećanja intenziteta drugog harmonika struje i napona u odnosu na prvi, što je rezultovalo nepravilnijim oblikom signala u vremenskom domenu. Zaključili smo da u uslovima male nominalne snage pražnjenja i velikog pritiska ulogu uzemljene elektrode preuzima neutralni gas koji se nalazi u prostoru između napajane i uzemljene elektrode. Takav režim, kada prielektrodna oblast nije formirana na uzemljenoj elektrodi, je postojao za skoro sve uslove pražnjenja (pritisk i snaga) tokom merenja bez dodatne elektrode. Posebno, za najveće primenjene snage i najmanji pritisak, prielektrodna oblast je formirana i na uzemljenoj elektrodi velikog poluprečnika. U tim uslovima su u obe geometrije dobijene približno iste vrednosti za I_{rms} , V_{rms} ali i za efikasnost predaje snage plazmi. U opštem slučaju, sistem je bio efikasniji kada je korišćena dodatna uzemljena elektroda. Veće RMS vrednosti napona su izmerene tokom pražnjenja sa elektrodom velikog poluprečnika dok su u drugom slučaju izmerene RMS vrednosti struje bile veće.

Maseno energijskim analizatorom je ispitivan sastav plazme i praćeni su doprinosi molekula i atoma kiseonika ali i argona za različite uslove pražnjenja. U konfiguraciji sa većom uzemljenom elektrodom su dobijeni spektri u kojima se nalazi nešto veći broj vrsta ali su i ukupni odbroji bili veći. Ova razlika postoji pre svega zbog blizine efektivnog zida komore, tokom merenja sa dodatnom uzemljenom elektrodom, na kome dolazi do intenzivne rekombinacije atomskog u molekulski kiseonik. Određena razlika može da postoji i zbog toga što su prielektrodne oblasti koje nastaju ispred otvora za uzorkovanje nešto drugačije tokom merenja sa različitim uzemljenim elektrodama. Kao i tokom merenja derivativnim sondama, primećeno je da povećanjem primenjene snage dolazi do povećanja aktivne oblasti pražnjenja, odnosno njene zapremine, i da se ono odvija brže kada je pritisak u komori bio manji. Ovaj efekat je skoro neprimetan kada je korišćena uzemljena elektroda manjeg poluprečnika. Odbroji O atoma su, na energiji jonizujućih elektrona od 20 eV bili manji kada se uzorkovanje vršilo na površini uzemljene elektrode (manjeg r). Međutim, njihovi doprinosi su bili značajno veći zbog toga što je i ukupan broj čestica ali i vrsta u spektru bio manji. Dodatna merenja su urađena i primenom metode masene spektrometrije praga za jonizaciju. Praćen je broj pobuđenih vrsta atoma i molekula kiseonika. Tokom merenja bez dodatne elektrode detektovani su veliki odbroji pobuđenih molekula i nešto manji odbroji atoma. Međutim kada je ona bila postavljena, izmereno je značajno manje pobuđenih molekula dok pobuđeni atomi nisu uopšte primećeni. Ovakvi rezultati takođe nastaju kao posledica intenzivnije plazme koja postoji oko otvora za uzorkovanje kada se pražnjenje odvija u konfiguraciji sa uzemljenom elektrodom većeg poluprečnika. Sa druge strane u konfiguraciji elektrode manjeg r, i prisustvo efektivnog zida komore utiče na maseni spektar jer na njemu dolazi do rekombinacije koja značajno smanjuje broj raspoloživih O atoma.

Koncentracija atomskog kiseonika i stepen disocijacije molekula su izmereni primenom metode optičke aktinometrije. Rezultati su dobijeni analizom spektara koji su snimljeni kroz prednji prozor komore, u pravcu ose sistema, i kroz bočni prozor, normalno na napajanu elektrodu. Dobijene su vrednosti koje su nešto drugačije, veće, od onih koje su mogle da se očekuju na osnovu rezultata masene spektrometrije. Razlike postoje kao posledica suštinski različitih metoda merenja. Time je pokazano da je za precizno poznavanje sistema dijagnostiku neophodno obaviti na više načina a da rezultati moraju da se interpretiraju imajući u vidu prednosti i mane, ali i princip rada, svake od metoda.

Tretmani su rađeni kako bi se proverio efekat plazme na aktivnost enzima (katalaze) mladice caričinog drveta, na povećanje klijavosti i suzbijanje infekcija kod komercijalnog semena ali i kako bi se procenila mogućnost za povećanu efikasnost i postojanije nanošenje mikrokapsula na površinu tkanine upotrebom plazme. Uzorci su tokom svih tretmana bili na postolju za uzorke, koje je uzemljeno. U smislu rezultata koji su dobijeni masenom spektrometrijom, uslovi tretmana su bliži onima koji su dobijeni tokom merenja sa manjom uzemljenom elektrodom. Aktivnost enzima i njegova količina u mladicama caričinog drveta je praćena tokom 4 dana klijanja. Tretmani su rađeni na dva pritiska, 200 mTorr i 600 mTorr, na nominalnoj snazi od 100 W i sa vremenima tretmana između jednog i dvadeset minuta. Nakon četvrtog dana klijanja je aktivnost enzima bila veća u semenima koja su duže tretirana na većem pritisku. Na isti način od uslova tretmana je zavisila i količina enzima u biljkama. Tretmani komercijalnog semena su rađeni, zavisno od vrste semena, na pritiscima od 300 mTorr i 500 mTorr i na snagama između 50 W i 200 W. Pokazano je da neće svako seme na isti način reagovati na iste uslove pražnjenja. Takođe je pokazano da uslove tretmana treba pažljivo odabrati jer je moguće „preterati“. Ukoliko je vreme tretmana predugačko ili je snaga pražnjenja velika dolazi do oštećenja semena što rezultuje opadanjem klijavosti i povećanjem stepena infekcije.

Tretmani sa ciljem nanošenja mikrokapsula su rađeni u azotu i kiseoniku sa trajanjem od 5 min i nominalnom snagom od 100 W. Tretmani u azotu su se pokazali kao uspešniji. Nakon tretmana u oba gasa je dolazilo do poboljšanja osobina poput otpornosti na cepanje i elastičnosti, ali su ovi efekti bili izraženiji nakon azotnih tretmana. Mirisne mikrokapsule su bile otpornije na pranje a miris postojaniji, takođe, u onim uzorcima koji su tretirani u N₂ plazmi.

3 PLAN-PARALELNO KAPACITIVNO SPREGNUTO PRAŽNENJE

Pored opisanog asimetričnog reaktora, u našoj laboratoriji je razvijen i plan paralelni reaktor kome je posvećena treća glava ove disertacije. Konstrukcija reaktora je vrlo slična GEC komori o kojoj je bilo reči u uvodu. Pražnjenje je dijagnostifikovano derivativnim sondama, optičkim metodama i Langmirovom sondom. Takođe, ovaj sistem je primenjen u tretmanima tekstila čemu će biti posvećen poslednji deo ove glave.

3.1 EKSPERIMENTALNA POSTAVKA

U ovom poglavlju ćemo opisati detalje vezane za sam reaktor, njegovu geometriju i specifičnosti konstrukcije i kako je u konkretnom slučaju primenjena svaka od dijagnostičkih metoda. Nešto više pažnje će biti posvećeno opisu sistema Langmirove sonde.

3.1.1 PLAN-PARALELNI PLAZMA REAKTOR

Plan paralelni reaktor je razvijen sa ciljem dobijanja intenzivnih homogenih plazmi veće zapremine u kojima bi se tretirali uzorci kojima su potrebni intenzivni fluksevi aktivnih čestica poput elektrona, jona i pobuđenih neutrala. Šema reaktora je prikazana na slici 3.1.1. Elektrode su izrađene od nerđajućeg čelika. Kružnog preseka su, paralelne jedna drugoj, i imaju prečnik od 11 cm. Donja elektroda je uzemljena i pričvršćena za dno komore preko zavrtnja tako da je moguće menjati njenu visinu a time i podešavati međuelektrodno rasutojanje. Tokom naših merenja i tretmana, međuelektrodno rastojanje je bilo između 4 i 7 cm. Tokom tretmana ona se koristi kao postolje za postavljanje uzoraka. Gornja elektroda ima dvostruku funkciju. Prva je da se kroz nju u komoru uvode gasovi. Sa ciljem da u prostoru između elektroda gas bude ravnomerno raspoređen, na gornjoj elektrodi se nalaze rupe u specifičnom simetričnom rasporedu (*eng showerhead*). To je i napajana elektroda koja je preko bakarnog uvodnika povezana na izvor RF signala.

Plan-paralelno kapacitivno spregnuto pražnjenje

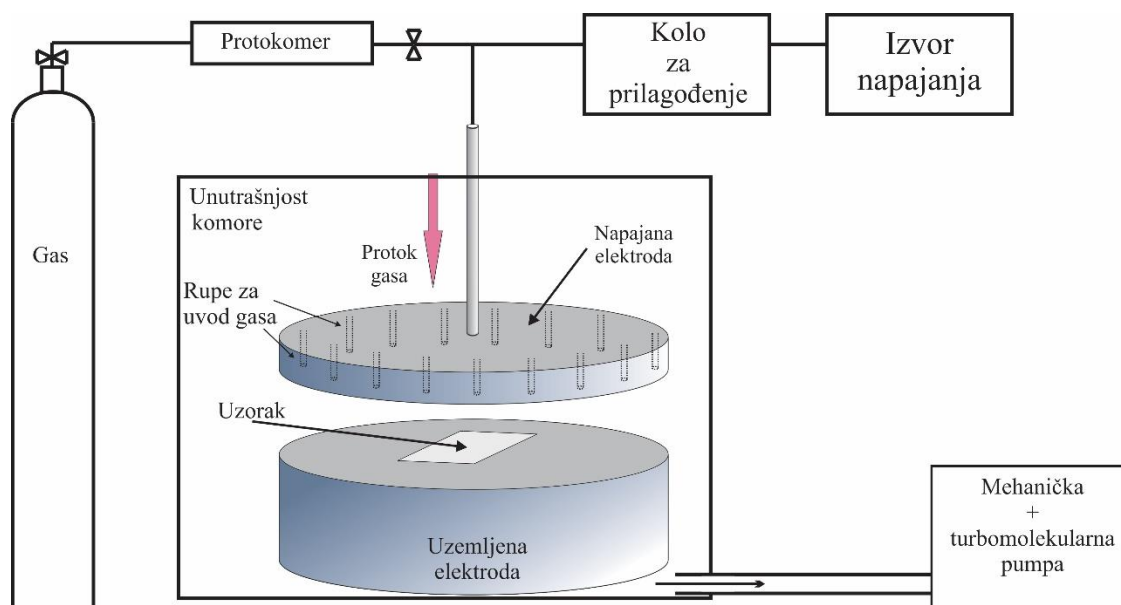

Slika 3.1.1 Šematski prikaz plan paralelnog plazma reaktora. Kroz napajanu elektrodu se upuštaju gasovi, donjoj elektrodi može da se podešava visina

Kako bi se postigao nizak pritisak, koristi se Pfeiffer Vacuum HiCUBE sistem koji je sačinjen od mehaničke i turbo-molekularne pumpe. Mehanička pumpa ima maksimalnu nominalnu brzinu ispumpavanja od 22 m³/h dok kod turbo pumpe ona iznosi 685 l/s. Obe veličine su normirane na protok azota. S obzirom na to da se turbina okreće brzinom od 49200 min⁻¹, proces vakuumiranja se mora obaviti pažljivo kako se ona ne bi oštetila. Problemi mogu da nastanu ukoliko je turbina dugo izložena velikom pritisku ili ukoliko do porasta pritiska dođe naglo. U prvom slučaju dolazi do porasta temperature zbog velike struje elektromotora koji pokreće turbinu dok u drugom postoji opasnost da dođe do mehaničkog krivljenja krilaca turbine. Kako bismo izbegli pomenute probleme tokom merenja ili tretmana koji zahtevaju češće otvaranje komore ili velike oscilacije pritiska, napravili smo direktnu vakuumsku vezu (*eng bypass*). Na taj način je omogućeno da se vakuumiranje obavlja samo mehaničkom pumpom dok pritisak ne padne na dovoljno malu vrednost na kojoj je bezbedno uključiti i turbo molekularnu. Merenje pritiska se obavlja pirani merilom (Pfeiffer Vacuum TPR-280) ili, u slučaju visokog vakuuma, merilom sa hladnom katodom (Pfeiffer Vacuum IKR-270).

Za napajanje sistema je korišćen isti izvor snage kao i kod asimetričnog reaktora, Dressler Cesar 1310. Kontakt je izveden preko uvodnika u obliku šipke koja se sa jedne strane ušrafi u napajanu elektrodu dok je sa njene druge strane povezana na električni konektor N-tipa. Prostor u kome se nalazi ogoljen napajani vod, odnosno pomenuta šipka, je smešten u cilindričnu kutiju od aluminijuma kako bi se sprečilo zračenje u okolni prostor ali i da bi se sprečila sprega napajanih i uzemljenih elemenata. Sistem za dovod gasova je od napajane elektrode, u električnom smislu, izolovan elementima od teflona.

3.1.2 DERIVATIVNE SONDE

Za merenje električnih osobina ovog sistema korišćene su iste sonde i procedura koja je opisana u drugoj glavi ove disertacije. Postavljene su direktno na N-konektor uvodnika tako da se, u električnom smislu, praktično nalaze najbliže napajanoj elektrodi sa spoljne strane aluminijumske kutije čime je u potpunosti izbegnuta sprega sa zračenjem napajanih voda.

3.1.3 OPTIČKA EMISIONA SPEKTROSKOPIJA

Za optičke metode karakterizacije tokom merenja u plan paralelnom reaktoru je upotrebljen Andor shamrock SR-750 spektrograf, Černi-Turner tipa (Czerny-Turner). Njegova žižna daljina iznosi 750 mm dok mu je f-broj $f/9,8$. U principu, spektrometar može da se koristi za analizu spektara u opsegu od 190 nm do 10 μm . Rezolucija talasne dužine iznosi 0,03 nm i zavisi od konkretnog detektora. Opremljen je automatskim biračem difrakcionih rešetki na kojem je moguće montirati maksimalno tri različite rešetke. Tokom naših merenja, koristili smo dve. Obe su napravljene od aluminijuma sa MgF_2 premazom. Broj proreza im je isti i iznosi 1200 mm^{-1} , dok su im maksimumi spektralne efikasnosti (*eng blaze*) na 300 i 500 nm. Širina ulaznog otvora je tokom svih merenja bila podešena na 20 μm .

Kao i kod asimetričnog reaktora, ispred prozora komore postavljeno je sabirno sočivo žižne daljine od 10 cm kako bi se svetlost fokusirala na ulazni otvor spektrometra. Tokom snimanja bio je maskiran gornji deo prozora kako bi se smanjio prostorni ugao i sprečilo prikupljanje svetla iz oblasti neposredno ispod napajane elektrode. Na taj način je dominantno posmatrana emisija iz oblasti između elektroda i uz uzemljenu elektrodu odnosno iz prostora neposredno iznad postavljenog uzorka.

Kao detektor na spektrometru je korišćena Andor iStar ICCD kamera (DH7341). Pored vremenski integrisanog snimanja spektra praćena je i evolucija određenih emisionih linija tokom vremena, za šta je korišćen režim koji se zove kinetičke serije (*eng kinetic series*). Šematska ilustracija ovog procesa data je na slici 3.1.2. Ovaj režim snimanja sastoji se od vremenski periodičnog niza snimaka pri čemu se periodičnost tj. frekvencija unapred zadaje. Jedan snimak u nizu može da se napravi jedim osvetljavanjem čipa (*eng single shot*) ali se, u slučaju kada je intenzitet prikupljene emisije nizak mogu koristiti i akumulacije. Posle svakog pojedinačnog snimka u nizu vrednosti matrice intenziteta sa čipa se skladišti u računaru a čip detektora da se vrati u početno stanje. Ovako dobijena matrica predstavlja jednu tačku kinetičke serije a broj tačaka se podešava u softveru kamere. Ukupno vreme snimanja zavisi od frekvencije i broja tačaka kinetičke serije.

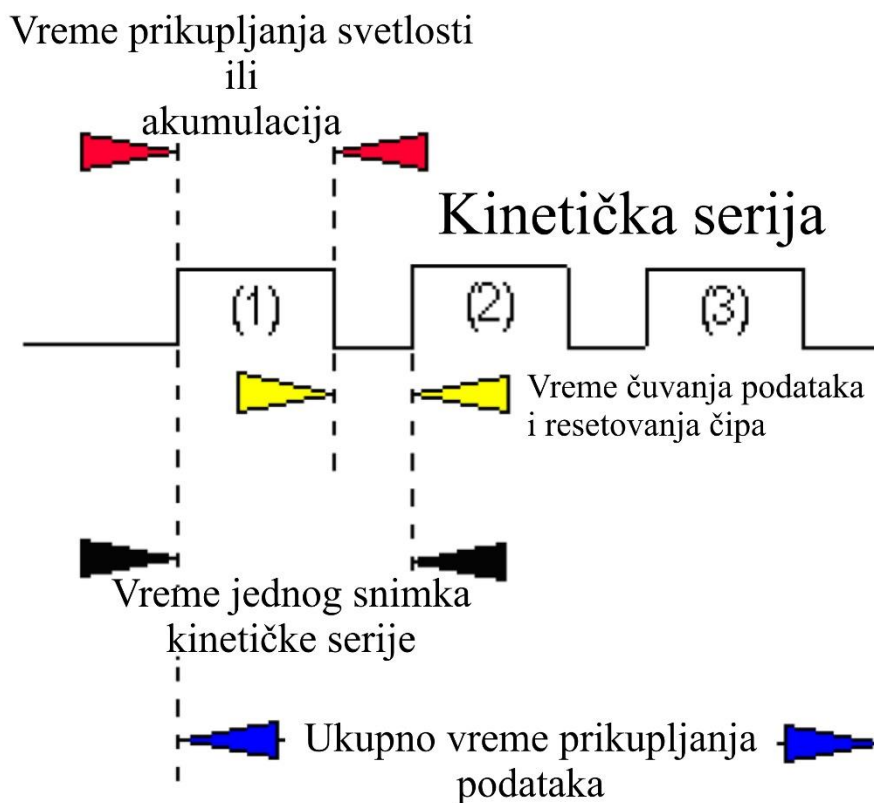

Slika 3.1.2 Šematski prikaz procesa snimanja u režimu kinetičke serije

Tokom merenja snimane su različite oblasti talasnih dužina što je omogućeno pomeranjem difrakcione rešetke. S obzirom na to da se pozicioniranje difrakcione rešetke obavlja automatski i da je kompjuterski kontrolisano, kalibraciju sistema nije neophodno uraditi pre svakog merenja.

3.1.4 LANGMIROVA SONDA

Za merenje plazmenog potencijala, koncentracije i temperature elektrona je korišćen komercijalno dostupan uređaj firme HIDDEN Analytical. U pitanju je Espion model Langmirove sonde. Konkretni primerak je opremljen automatskim sistemom za pozicioniranje (*eng* Automatic Z-drive). Ukupan „hod“ sonde iznosi 30 cm i precizan je u okviru greške od 0,1 mm. Nosač sonde, odnosno njeno telo, je izrađen od Al_2O_3 keramike. Za izradu vrha sonde se može koristiti više od dvadeset različitih materijala i nekoliko geometrija. U našim merenjima je korišćen cilindrični vrh od volframa dužine 10 mm i širine 0,15 mm. Šematski prikaz konstrukcije vrha sonda dat je slici 3.1.3.

Već smo pomenuli da kod ovakvog tipa sonde mogu da nastanu problemi vezani za frekventni odziv kada se merenja obavljaju u pražnjenjima sa brzim promenama napona. Kako bi se takvi problemi sveli na minimum, ovaj uređaj je opremljen sistemom pasivne RF kompenzacije. Kompenzaciona elektroda je napravljena od eloksanog aluminijuma. Na sistem sonde je pričvršćena navojem što obezbeđuje dobar električni kontakt a omogućava da se sama elektroda promeni ukoliko dođe do kontaminacije površine. Takođe, da bi se kompenzovala promene malih frekvencija koje mogu da nastanu zbog promena plazmenog potencijala ili problema u izvoru napajanja, ovaj sistem je opremljen i referentnom elektrodom koja je napravljena od nerđajućeg čelika.

Plan-paralelno kapacitivno spregnuto pražnjenje

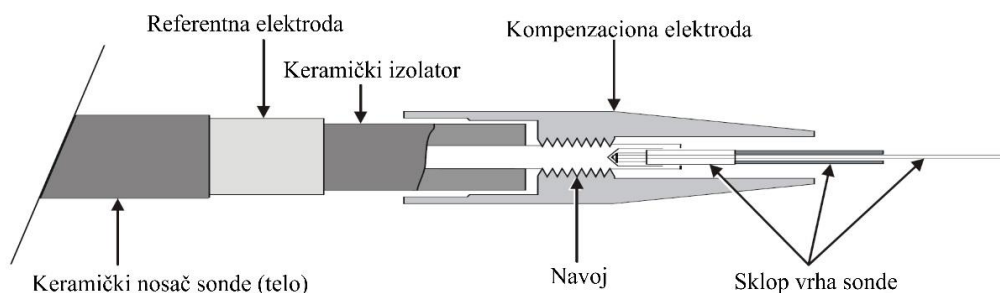

Slika 3.1.3 Šematski prikaz konstrukcije sonde

Sondu je moguće napajati naponom od -100 V do 100 V sa koracima koji se mogu podešavati između 0,01 i 1 V. Pre merenja je potrebno podesiti i opseg struje koji može da bude 1, 10, 100 ili 1000 mA. Korisničkim softverom se može podesiti da svako merenje strujno-naponske karakteristike predstavlja zapravo usrednjenu vrednost većeg broja izmerenih krivih, a broj krivih za usrednjavanje može ići i do 1000. Radi povećanja preciznosti i smanjenja šuma je omogućeno podešavanje minimalnog vremena koje će sistem da iskoristi za snimanje svake pojedinačne krive i ono može da iznosi između jedne milisekunde i 30 s. Pre snimanja svake krive, ili čak svake pojedinačne tačke na strujno-naponskoj krivoj, vrh sonde je moguće očistiti tako što se postavi na određenu vrednost napona, između -200 V i 100 V. U našoj laboratoriji je na osnovu niza merenja sa različitim parametrima uspostavljena praksa da se pre snimanja svake krive vrh sonde ostavi 200 ms na minimalnoj tački opsega napona koji se koristi za dobijanje I-V krive. Međutim, čak i tako dobijene i usrednjene krive su često „izlomljene“ - sa vrednostima koje osciluju oko idealno glatkog oblika krive. Kako bi se kao krajnji rezultat dobila glatka I-V karakteristika koristi se Savicki-Golaj algoritam (Savitzky-Golay) koji numeričkim metodama može, pored ostalog, i da poboljša odnos signal/šum. Ovaj algoritam u softveru ima podesivu širinu opsega pri primeni i ona iznosi između 3 i 25 tačaka. Iako korisnički program sonde nudi mogućnost obrade podataka korišćenjem kako OML tako i ABR teorije, zbog veće mogućnosti pri obradi i analizi signala I-V karakteristike su nakon snimanja i primene Savicki-Golaj algoritma izvezene i analizirane ručno.

Elektronska struja sonde za nemagnetne plazme na niskom pritisku može da se izrazi preko formule:

$$I_e(U) = -\frac{2\pi eS}{m^2} \int_{eU}^{\infty} (W - eU) f(W) dW . \quad (3.1)$$

Ovde je sa e i m obeleženo naelektrisanje i masa elektrona respektivno, S je površina sonde a W je ukupna energija elektrona u prielektrodnoj oblasti sonde i ona iznosi $\frac{mv^2}{2} + eU$. Oznakom U je obeležena razlika napona između sonde i plazmenog potencijala. Ukoliko je $f(\varepsilon)$ izotropna funkcija raspodele, odnosno verovatnoće, elektrona po energijama važiće:

$$\frac{4\pi\sqrt{2}}{m^{3/2}} \int_0^{\infty} f(W) \sqrt{W} dW = \int_0^{\infty} f(\varepsilon) \sqrt{\varepsilon} d\varepsilon = n. \quad (3.2)$$

Funkcija raspodele se može odrediti iz sledeće formule:

$$f(\varepsilon) = \frac{2\sqrt{2m}}{e^3 S} \frac{d^2 I_e(U)}{dU^2}, \quad (3.3)$$

odakle se vidi da će ona zavisiti od drugog izvoda struje po naponu. Sam proces diferenciranja funkcije tj. izmerene strujno-naponske krive se obavlja numerički uz pomoć računara.

3.2 REZULTATI MERENJA I DISKUSIJA

3.2.1 DERIVATIVNE SONDE

U ovom poglavlju će biti opisane električne osobine plan paralelnog sistema koje su dobijene merenjem tokom pražnjenja u dva gasa, argonu i azotu, i na dva rastojanja između napajane i uzemljene elektrode, 4 cm i 7 cm. Kao i tokom ispitivanja u asimetričnom reaktoru, neophodno je odrediti kapacitivnost sistema kako bi iz izmerene vrednosti struje mogla da se dobije vrednost struje u plazmi, bez struje pomeraja. U tu svrhu je korišćena procedura opisana u poglavlju 2.2.1. Da bi se dobile vrednosti struje i napona između elektroda kada u tom prostoru ne dolazi do pražnjenja, upuštanjem vazduha pritisak u komori je podignut do atmosferskog. Primenom već objašnjene procedure merenja dobijaju se impedanse od $98,5 \Omega$ za rastojanje između uzemljene i napajane elektrode od 4 cm, i 100Ω za rastojanje od 7 cm. Uz pretpostavku da je impedansa dominantno kapacitivnog karaktera iz formule za impedansu kondenzatora smo izračunali vrednost kapacitivnosti koja za rastojanje između elektroda od 4 cm iznosi $119,2 \text{ pF}$ dok je za rastojanje od 7 cm ona nešto manja i iznosi $117,4 \text{ pF}$. Treba imati na umu da se, zbog konstrukcije reaktora, dobijena kapacitivnost ne odnosi samo na prostor između napajane i uzemljene elektrode već na celokupni prostor između napajane elektrode i uzemljenih elemenata komore, pre svega njenih metalnih zidova. Zbog ovako velike kapacitivnosti sistema može da se očekuje i veliki doprinos struje pomeraja u izmerenoj struji.

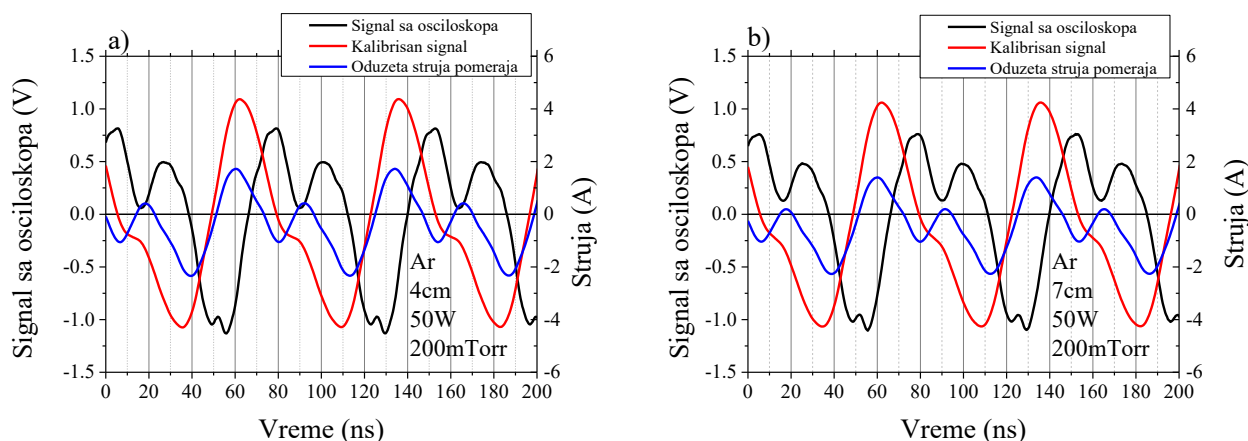

Slika 3.2.1 Primeri strujnih signala koji su dobijeni sa međuelektrodnim rastojanjem od a) 4 cm i b) 7 cm. Crnom bojom su označeni signali izmereni direktno sa osciloskopa (vrednosti su u voltima); strujni signali nakon množenja kalibracionim krivama (vrednosti u amperima) prikazani su crvenom bojom; nakon oduzimanja struje pomeraja – plavom bojom.

Primeri strujnih signala dobijenih u različitim koracima procedure obrade za pražnjenje u argonu je prikazan na slici 3.2.1. Krive dobijene na rastojanju između elektroda od 4 cm prikazane su na slici 3.2.1. a) dok su za rastojanje od 7 cm prikazane na slici 3.2.1 b).

Signali dobijeni direktno sa osciloskopa imaju vrlo nepravilan oblik sa po dva maksimuma u pozitivnom i negativnom poluperiodu i praktično su identični za oba rastojanja. Nakon množenja signala sa kalibracionim krivama dobijen je signal u kome je jedan maksimum u pozitivnom delu

perioda značajno većeg intenziteta ali koji takođe vidljivo odstupa od pravilne sinusoide. Odstupanje strujnih signala od pravilne sinusoide nije nepoznat fenomen. Snažan doprinos viših harmonika u ukupnom signalu je primetio Roberts sa saradnicima još 1991.-e godine, takođe u GEC komori [185]. U njihovim signalima je dominantan bio treći harmonik što je izazvalo još izraženija odstupanja od sinusnog oblika signala u odnosu na naša merenja. Takođe, u jednom od prvih radova koji su vezani za dijagnostiku i standardizaciju električnih osobina GEC komore Sobolevski (Sobolewski) je razmatrao uticaj struje pomeraja i zaključio da je njen doprinos u ukupnoj struji dominantan i da provodna struja može da se zanemari [186]. Na slici 3.2.1 je prikazan i signal struje nakon oduzimanja struje pomeraja. Vidi se da je u našim merenjima efekat struje pomeraja značajan, ali da ne možemo da zanemarimo struju izazvanu kretanjem naelektrisanja u pražnjenju. Takođe, nakon oduzimanja struje pomeraja signal struje ima negativnu vrednost u većem delu perioda što se događa kao posledica oduzimanja velike struje pomeraja od ukupnog strujnog signala. Slična situacija je takođe zabeležena u literaturi [187].

Primeri signala koji su dobijeni sa naponske sonde, pre i posle množenja kalibracionim krivama su prikazani na slici 3.2.2. Može da se primeti da rastojanje između elektroda neće značajno uticati na oblik zavisnosti napona od vremena. Oblik naponskih signala iako su prisutne infleksije ima sličnosti sa sinusnim signalom, a nakon množenja sa kalibracionim krivama dobija se vremenska zavisnost vrlo pravilnog sinusnog oblika.

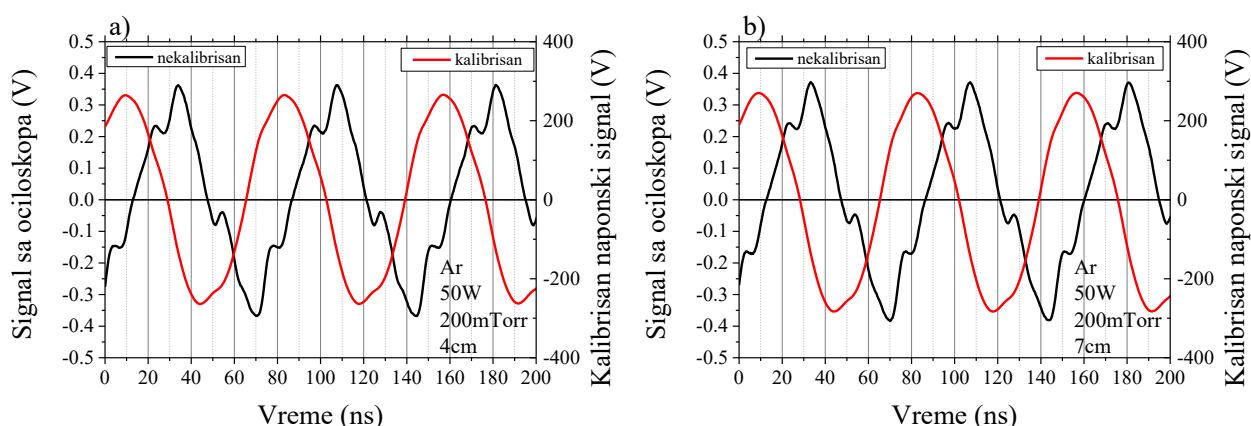

Slika 3.2.2 Primeri naponskih signala koji su dobijeni sa međuelektrodnim rastojanjem od a) 4 cm i b) 7 cm. Crnom bojom su obeleženi signali koji su dobijeni direktno sa osciloskopa dok su crvenom bojom obeleženi signali nakon množenja kalibracionim krivama.

Plan-paralelno kapacitivno spregnuto pražnjenje

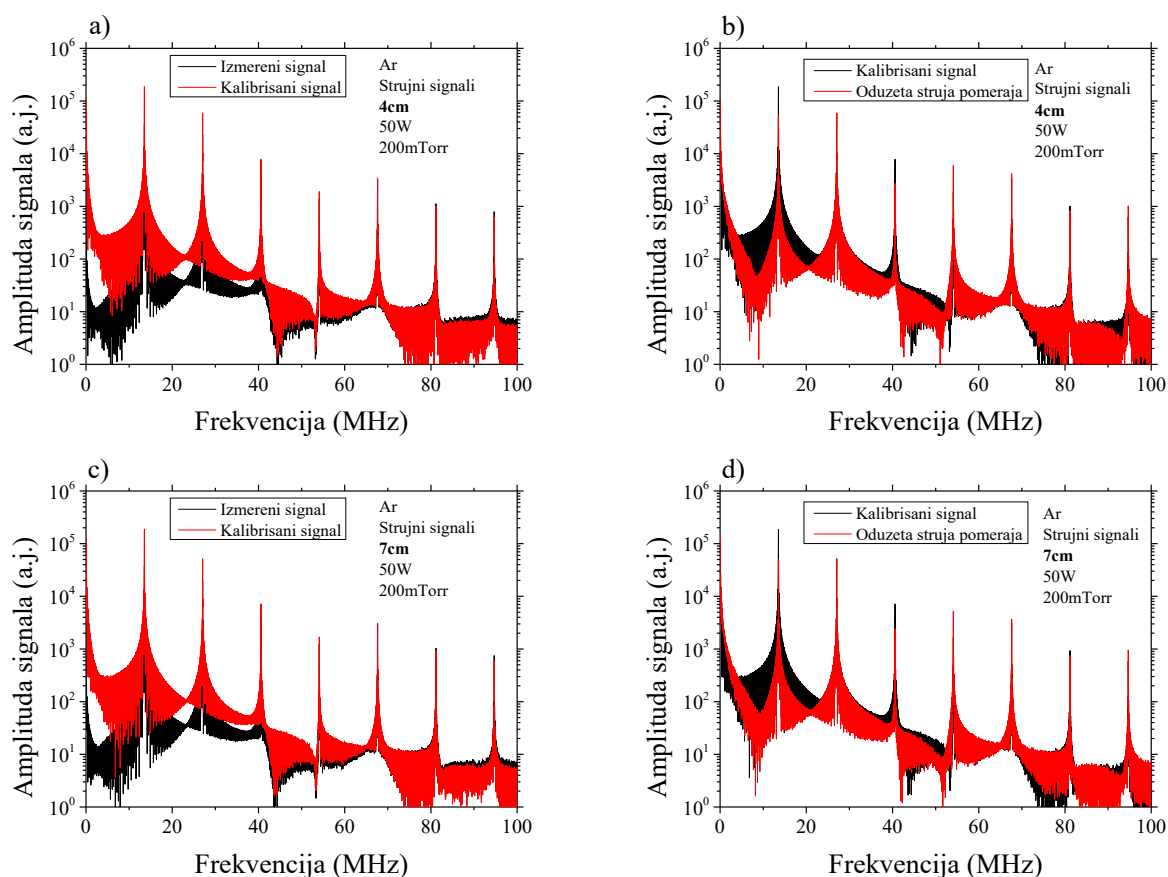

Slika 3.2.3 Zavisnost amplitude strujnih signala od frekvencije za međuelektrodno rastojanje od 4 cm (a i b,) i 7 cm (c i d,.) neobrađenog signala i posle množenja kalibracionim krivama (a i c,) i nakon oduzimanja struje pomeraja (b i d,.)

Poređenje amplituda strujnih signala u zavisnosti od frekvencije, pre i posle množenja kalibracionim krivama, je za dva međuelektrodna rastojanja prikazano na slikama 3.2.3 a) i 3.2.3c). U primeru sa slike je pritisak bio podešen na 200 mTorr dok je nominalna snaga pražnjenja iznosila 50 W. Kao i u slučaju asimetričnog reaktora (deo 2.2.1) amplitude na malim frekvencijama zbog oblika kalibracionih krivih značajno su veće kod kalibrisanih signala. Na visokim frekvencijama su amplitude signala sa osciloskopa veće. Promena rastojanja između napajane i uzemljene elektrode ne dovodi do značajne razlike u amplitudama signala. Na slikama 3.2.3 b) i d) prikazano je poređenje amplituda u zavisnosti od frekvencije između kalibrisanog signala i nakon što mu se oduzme struja pomeraja. Primetno je da je su amplitude nakon oduzimanja nešto manje u celom u opsegu prikazanih frekvencija, dok je razlika među njima nešto izraženija na nižim frekvencijama, pogotovo na prvom i trećem harmoniku.

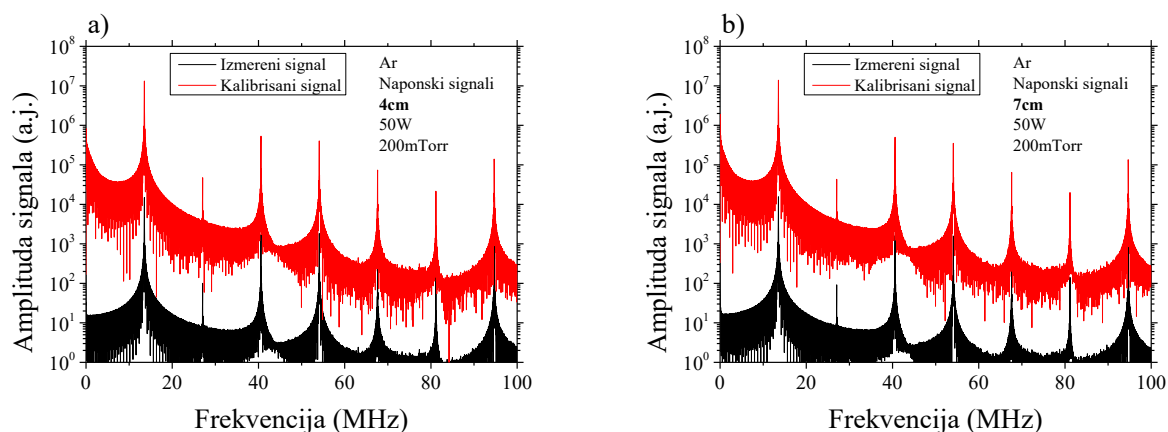

Slike 3.2.4 Zavisnost amplitude naponskog signala od frekvencije za međuelektrodno rastojanje od a) 4 cm i b) 7 cm. Signal dobijen sa osciloskopa je obeležen crnom bojom dok je signal pomnožen kalibracionim krivama obeležen crvenom bojom.

Poređenje amplituda naponskih signala je za iste uslove pražnjenja (Ar, 50 W, 200 mTorr), pre i posle procesa množenja kalibracionim krivama dato na slici 3.2.4 i to za međuelektrodno rastojanje od a) 4 cm i b) 7 cm. Može da se primeti da su, očekivano, amplitude kalibriranih signala nekoliko redova veće od signala koji su dobijeni direktno sa osciloskopa i da ta razlika opada sa porastom frekvencije. Treba primetiti da je među prvih pet harmonika, najmanji intenzitet amplitude naponskih signala zabeležen na drugom harmoniku i da je on praktično 4 reda veličine slabiji u odnosu na amplitudu na osnovnoj frekvenciji.

Na slici 3.2.5 je pokazano kako neobrađeni signali, dobijeni direktno sa osciloskopa, zavise od snage. Na slikama 3.2.5 a) i b) su prikazani strujni signali za dva različita međuelektrodna rastojanja dok je na slikama 3.2.5 c) i d) prikazano kako izgledaju naponski signali. Strujni signali izgledaju vrlo nepravilno i na najmanjoj primenjenoj snazi, od 10 W. Povećanjem snage dolazi do porasta ukupne vrednosti struje ali i izobličenja, odnosno efekti viših harmonika postaju sve vidljiviji. Na najvišoj nominalnoj snazi, od 75 W, strujni signali na oba rastojanja između elektroda su deformisani i ne podsećaju na sinusni signal. Nešto veći intenzitet neobrađenog strujnog signala je zabeležen na rastojanju od 4 cm.

Plan-paralelno kapacitivno spregnuto pražnjenje

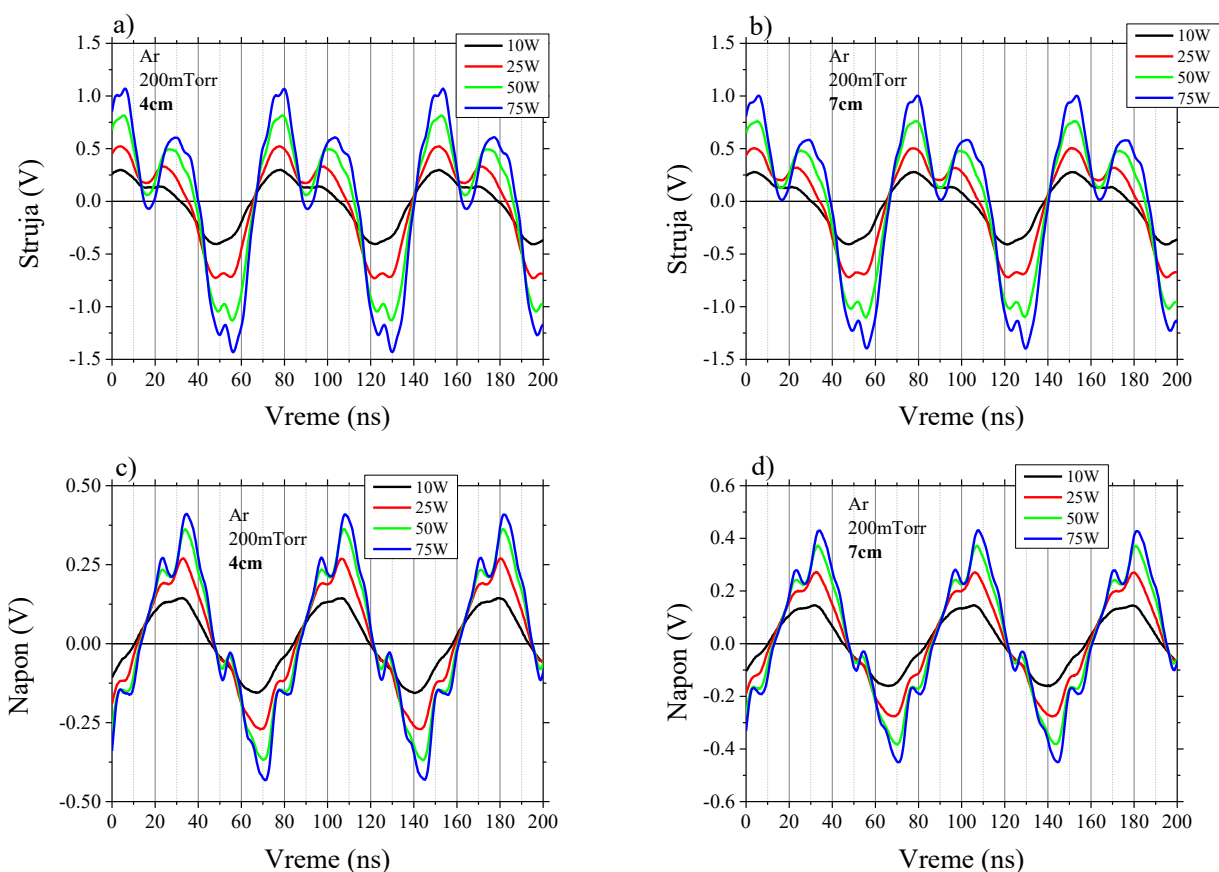

Slika 3.2.5 Poređenje neobrađenih strujnih i naponskih signala u zavisnosti od primenjene snage za rastojanje između elektroda od 4 cm (a) i c)) i 7 cm (b) i d)).

Neobrađeni naponski signali prikazani su na slikama 3.2.5 c) i d). Na najmanjoj snazi, na oba rastojanja između elektroda, oni imaju oblik približan sinusoidi. Međutim sa povećanjem nominalne snage pražnjenja i efekti viših harmonika postaju značajni što dovodi do deformacija signala i njegovog odstupanja od pravilne sinusoidne, mada u značajno manjoj meri nego što je to bio slučaj kod strujnih signala. Amplituda neobrađenog naponskog signala je, takođe, bila nešto veća kada je rastojanje između elektroda bilo manje.

Plan-paralelno kapacitivno spregnuto pražnjenje

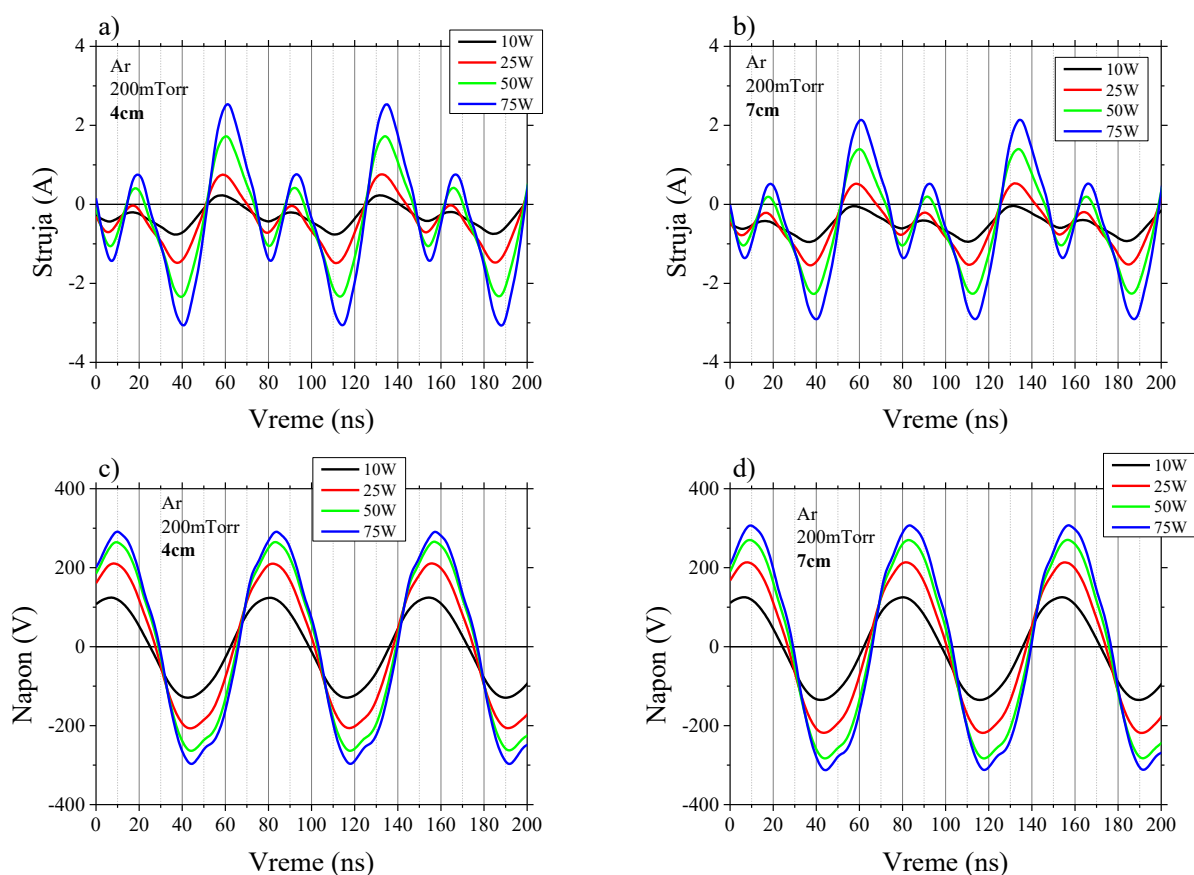

Slika 3.2.6 Poređenje strujnih a) i b) i naponskih c) i d) signala nakon množenja sa kalibracionim krivama, za međuelektrodna rastojanja od a) i c) 4 cm i b) i d) 7 cm. Od strujnih signala je oduzeta struja pomeraja.

Zavisnosti obrađenih strujnih i naponskih signala, odnosno njihovih vrednosti nakon množenja kalibracionim krivama i oduzimanja struje pomeraja, od primenjene snage su za oba međuelektrodna rastojanja prikazane na slikama 3.2.6 a), b), c) i d). Oblik strujnih signala je gotovo identičan kao u merenjima koja je obavio Roberts 1991.-e [185], ali su intenziteti za red veličine veći. Odstupanje od pravilnih sinusoida je vrlo primetno i na najmanjim snagama. Podsetimo se da se na slikama 3.2.4 b) i d), na kojima je predstavljena zavisnost amplitude obrađenog strujnog signala od frekvencije, vidi da su njihovi intenziteti na osnovnom i drugom harmoniku praktično identični. Imajući to u vidu, može da se očekuje da će strujni signali u vremenskom domenu u okviru jednog perioda (od 74 ns) imati dvostruki maksimum i dvostruki minimum. Na slikama 3.2.6 a) i c) se vidi da su, nakon obrade, dobijene upravo ovakve zavisnosti struje od vremena. Dodatno, s obzirom na to da su doprinosi viših harmonika značajno manji od prvog i drugog, dobijeni signali izgledaju kao super pozicija dva signala od kojih jedan ima duplo veću frekvenciju od drugog. Odnosno, izgledaju kao približno pravilna kriva oblika $\sin(\omega t) + \sin(2\omega t)$. Na slikama 3.2.6(c) i 3.2.6(d) je prikazano kako obrađeni naponski signal zavisi od primenjene snage. Iako određene nepravilnosti postoje, ove krive, pogotovo na malim nominalnim snagama, mnogo više liče na pravilne sinusoida. U datom opsegu snaga, od 10 do 75 W, amplituda naponskog signala povećala se skoro tri puta na oba međuelektrodna rastojanja.

Plan-paralelno kapacitivno spregnuto pražnjenje

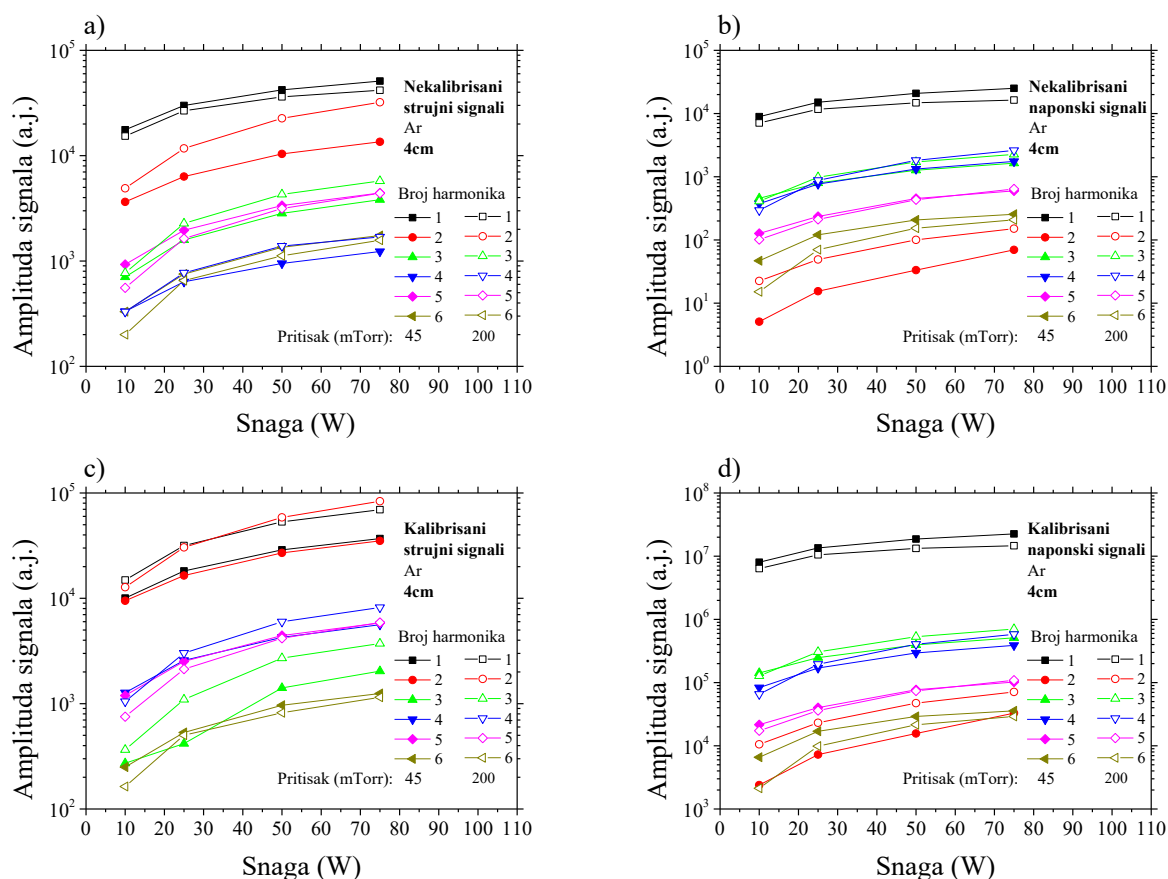

Slika 3.2.7 Amplitude prvih 6 harmonika, strujnih (a) i c)) i naponskih (b) i d)) signala koji su dobijeni direktno sa osciloskopa (a) i b)) i nakon obrade (c) i d)) za rastojanje između elektroda od 4 cm. Rezultati su izmereni na dva pritiska: 45mTorr – puni simboli, 200mTorr – prazni simboli.

Efekat primenjene snage na frekventni sastav strujnih i naponskih signala, odnosno na prvih 6 harmonika, je za međuelektrodno rastojanje od 4 cm prikazan na slici 3.2.7. U gornjem delu slike, 3.2.7 a) i b), predstavljeno je kako snaga utiče na promenu intenziteta prvih 6 harmonika nekalibrisanih signala, odnosno onih koji su dobijeni direktno sa osciloskopa, za pritiske od 45 mTorr i 200 mTorr. Iako je kod nekalibrisanog strujnog signala najintenzivnija amplituda na osnovnoj frekvenciji, vrednost drugog harmonika nije značajno manja. Odnos amplituda na ove dve frekvencije (13,56 MHz i 27,12 MHz) je najveći na snazi 10 W i pritisku od 45 mTorr kada je prvi harmonik ~5 puta intenzivniji od drugog. Povećanjem snage i pritiska se njihova razlika smanjuje pa je na pritisku od 200 mTorr i nominalnoj snazi pražnjenja od 75 W prvi harmonik svega 30 % intenzivniji od drugog. Zbog toga se na višim snagama praktično ne prepoznaje sinusna osnova pobudnog signala. Kod neobrađenog naponskog signala je osnovni harmonik znatno dominantniji. Zanimljivo je primetiti da je intenzitet drugog harmonika zapravo najmanji, među prvih 6 prikazanih, i da je oko 3 reda veličine manjeg intenziteta od osnovnog. Intenziteti trećeg i četvrtog harmonika su praktično identični i od osnovnog su, zavisno od snage, 6 do 20 puta manji. Zbog toga što je doprinos drugog harmonika toliko mali i zbog toga što ni viši harmonici nisu previše intenzivni, vremenski oblik nekalibrisanog naponskog signala izgleda kao „nazubljena“ sinusoida.

Nakon amplitudne i fazne korekcije strujnih i naponskih signala, harmonijski sastav izgleda nešto drugačije i prikazan je na slikama 3.2.7 c) i d). Kod strujnog signala će, na pritisku od 45 mTorr, osnovni harmonik i dalje biti najintenzivniji ali će intenzitet drugog harmonika biti svega nekoliko procenata manji a njihova razlika će opadati sa povećanjem nominalne snage. Na 75 W njihovi intenziteti će biti praktično identični. Međutim na 200 mTorr će drugi harmonik biti slabiji od osnovnog samo na dve najmanje snage. Već na 50 W će njegov intenzitet nadmašiti osnovni, dok će

Plan-paralelno kapacitivno spregnuto pražnjenje

na snazi od 75 W ta razlika iznosi 20 % u korist drugog harmonika. Amplitude viših harmonika ne prelaze 10 % intenziteta osnovnog. Zbog ovakvog harmonijskog sastava čak i obrađeni strujni signali imaju jasno vidljiv doprinos drugog harmonika. Međutim, nakon što se izvrši fazna i amplitudna korekcija naponskih signala, osnovni harmonik će biti još dominantniji nego pre korekcije. Intenzitet drugog harmonika, koji je i dalje najslabiji u spektru, je sada 3 do 4 reda veličine manji od osnovnog dok će intenzitet na trećem harmoniku biti 20 do 45 puta manji od osnovnog. Zbog toga će nakon množenja kalibracionim krivama naponski signali izgledati kao prilično pravilne sinusoide.

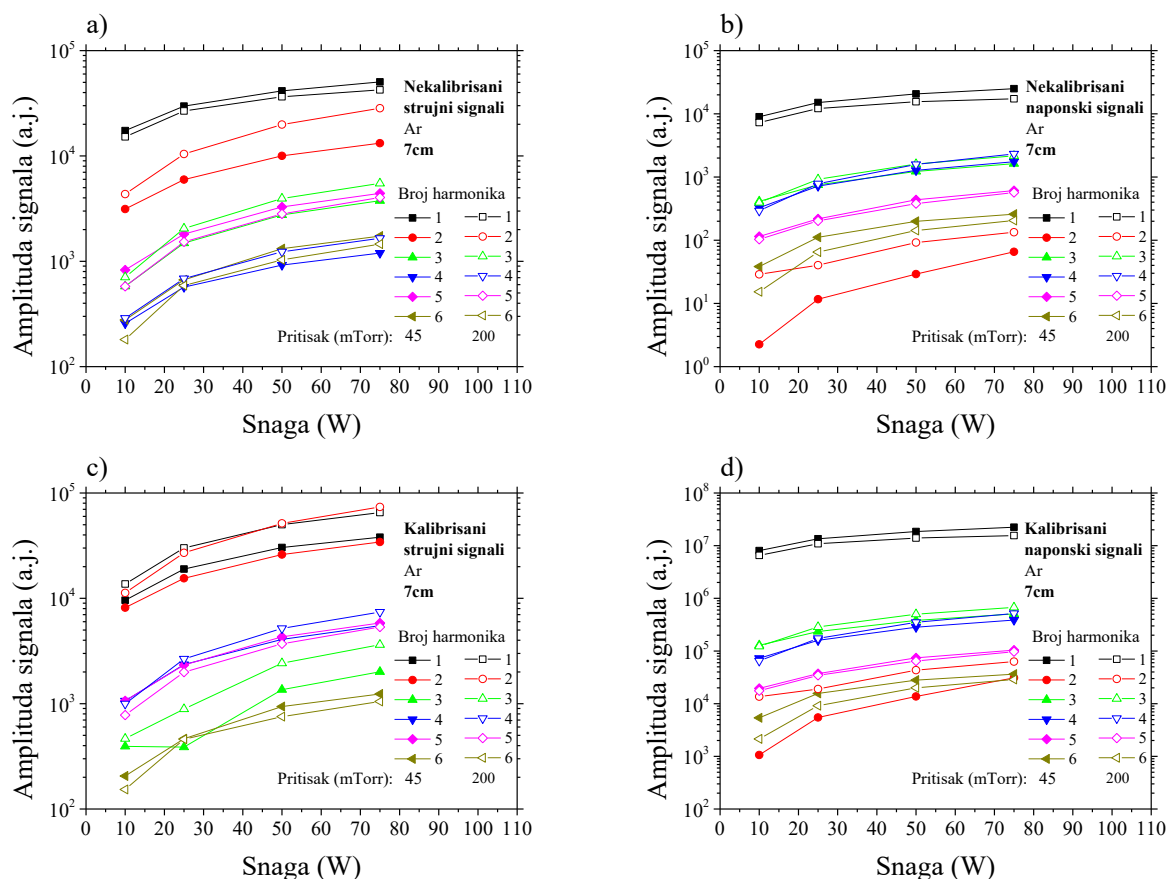

Slika 3.2.8 Amplitude prvih 6 harmonika strujnih (a) i c)) i naponskih (b) i d)) signala koji su dobijeni direktno sa osciloskopa (a) i b)) i nakon obrade (c) i d)) sa rastojanjem između elektroda od 7 cm. Rezultati su izmereni na dva pritiska: 45mTorr – puni simboli, 200mTorr – prazni simboli.

Frekventni sastav električnih signala za međuelektrodno rastojanje od 7 cm i njihova zavisnost od primenjene snage i pritiska je prikazan na slici 3.2.8. Kod nekalibrisanog strujnog signala, slika 3.2.8 a), je prvi harmonik dominantniji a od drugog je veći između 50 % (200mTorr, 75 W) do čak 5,6 puta (10 W, 45 mTorr). Ova razlika se, kao i na manjem rastojanju, smanjuje sa povećanjem primenjene snage. Kod nekalibrisanog naponskog signala je takođe dominantan prvi harmonik. Intenzitet drugog harmonika je nekoliko redova manji od prvog i on je, na pritisku od 45 mTorr, zapravo najmanje intenzivan harmonik od prvih 6 prikazanih. Treći i četvrti harmonik imaju gotovo identične intenzitete koji su od osnovnog manji između 7,5 i 18 puta. Kao i kod neobrađenih strujnih signala ta razlika se smanjuje sa povećanjem primenjene snage.

Nakon amplitudne i fazne korekcije će se, kod strujnih signala, razlika između amplituda prvog i drugog harmonika smanjiti. Slično kao i kada je rastojanje između elektroda iznosi 7 cm, na pritisku od 200 mTorr će drugi harmonik biti intenzivniji od prvog za nominalne snage pražnjenja od 50 i 75 W. Međutim, na ovom rastojanju će njihova razlika biti nešto manja pa će na snazi od 75 W

Plan-paralelno kapacitivno spregnuto pražnjenje

drugi harmonik biti oko 10 % intenzivniji od prvog. Na manjem pritisku je osnovni harmonik u celom opsegu snaga intenzivniji od drugog, ali su njihove vrednosti vrlo slične pa na najvećoj nominalnoj snazi njihova razlika iznosi manje od 12 %. Intenzitet ostalih viših harmonika je za minimum jedan red veličine manji od osnovnog zbog čega obrađeni vremenski strujni signali, u vremenskom domenu, izgledaju kao glatka superpozicija dva signala od kojih jedan ima duplo veću frekvenciju od drugog. Kod obrađenog naponskog signala su, posle osnovnog, najintenzivniji treći i četvrti harmonik koji čine svega nekoliko procenata osnovnog.

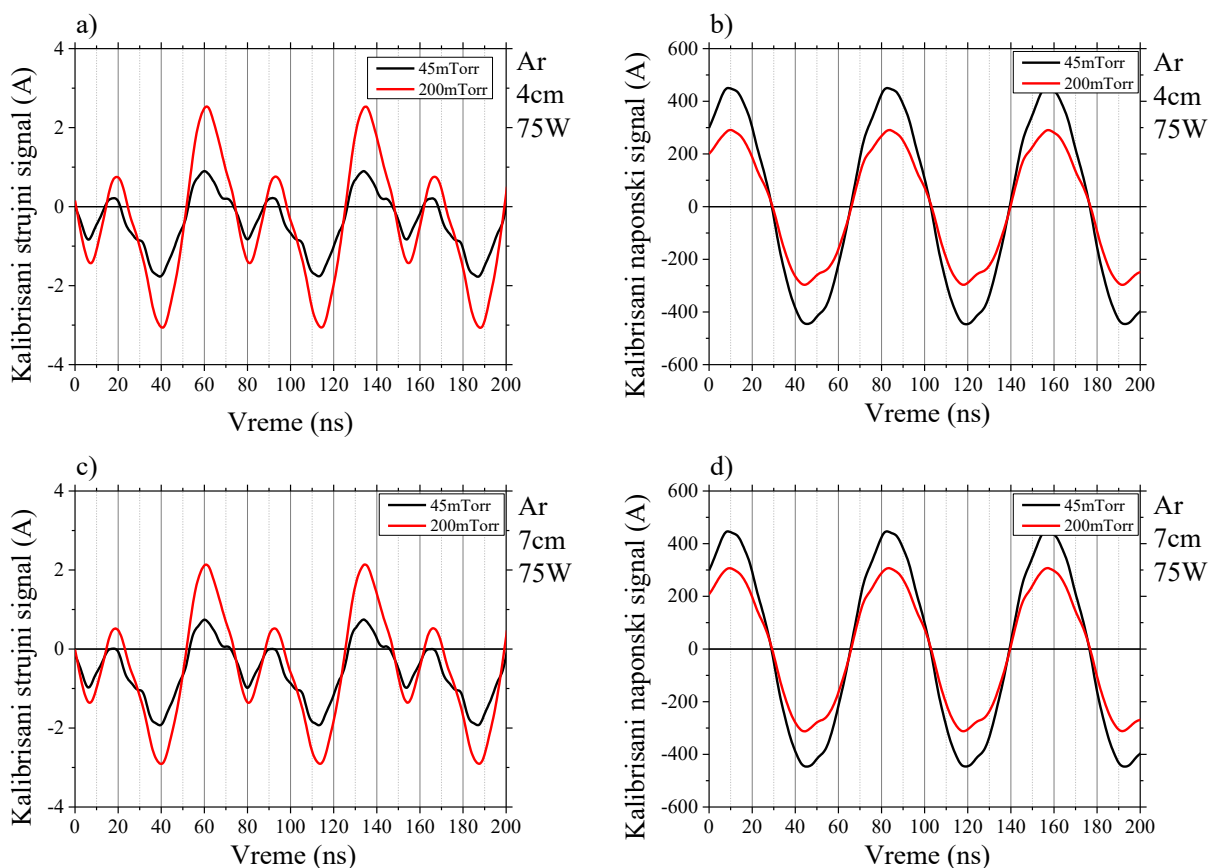

Slika 3.2.9 Efekat promene pritiska na strujne, a) i c), i naponske, b) i d), signale na međuelektrodnim rastojanjima od 4 cm, a) i b), i 7 cm, c) i d), na snazi od 75 W.

Efekat promene pritiska na vremenske zavisnosti strujnih i naponskih signala je prikazan na slici 3.2.9 za fiksnu nominalnu snagu pražnjenja od 75 W. Rezultati su predstavljeni za oba međuelektrodna rastojanja. Može da se primeti da će amplitude strujnih signala, koji su predstavljeni na slikama 3.2.9 a) i c), biti veće kada se pražnjenje odvija na višem pritisku. Njihov ukupni porast pri promeni pritiska sa 45 na 200 mTorr iznosi oko dva puta. Takođe, na pritisku od 45 mTorr je nešto vidljiviji doprinos viših harmonika odnosno kriva je manje glatka. Kod naponskih signala promena pritiska izaziva potpuno suprotan efekat, odnosno sa povećanjem pritiska dolazi do pada amplitude napona. Drugim rečima, smanjenje pritiska sa 200 na 45 mTorr dovodi do porasta napona od nešto preko 40 %.

Plan-paralelno kapacitivno spregnuto pražnjenje

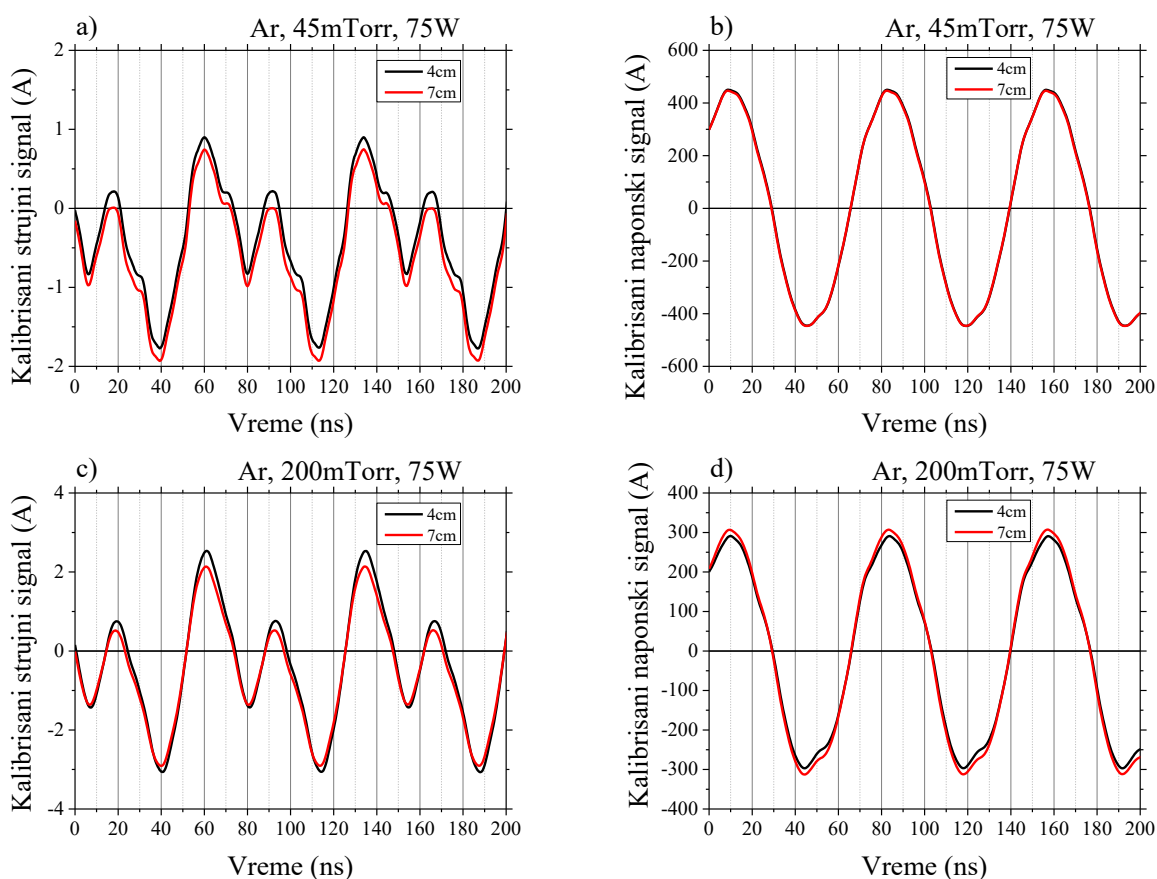

Slika 3.2.10 Efekat promene međuelektrodnog rastojanja na obrađene strujne, a) i c), i naponske, b) i d), signale na pritiscima od 45 mTorr, a) i b), i 200 mTorr, c) i d), na snazi od 75 W.

Kada menjamo rastojanje između napajane i uzemljene elektrode u plan paralelnom sistemu, mi praktično menjamo samo kapacitivnost kondenzatora koji te dve elektrode formiraju. S obzirom da je ta promena u našem sistemu relativno mala, svega par procenata, ne očekujemo da će promena međuelektrodnog rastojanja dovesti do velike promene u obliku i intenzitetu strujnih i naponskih signala. Na slici 3.2.10 je predstavljeno poređenje vremenskih zavisnosti obrađenih strujnih, 3.2.10 a) i c), i naponskih, 3.2.10 b) i d), signala koju su dobijeni na pritiscima od 45 mTorr, 3.2.10 a) i b), i 200 mTorr, 3.2.10 c) i d), za fiksnu nominalnu snagu od 75 W. S obzirom na to da su razlike veoma male, možemo da kažemo da je pretpostavka bila tačna odnosno da promena rastojanja između elektroda neće da dovede do značajne promene ni struje ni napona. Na pritisku od 45 mTorr menjanje rastojanja ne dovodi praktično ni do kakve promene u obliku i intenzitetu strujnog signala, osim što je on na manjem rastojanju nešto pozitivniji. Praktično je cela kriva, na manjem rastojanju, „podignuta“ za oko 0,16 A, što može da bude i posledica eksperimentalne greške. Naponski signali su, na pritisku od 45 mTorr, praktično identični za oba međuelektrodna rastojanja. Na većem pritisku su razlike nešto veće ali i dalje nisu značajne. Povećanjem rastojanja je struja opala za desetak procenata dok napon porastao za oko 5 %.

S obzirom na to da su razlike signala u vremenskom domenu na 45 mTorr praktično zanemarljive i na najvećoj primenjenoj snazi, razliku frekventnog sastava signala za dva različita rastojanja između elektroda ćemo predstaviti samo za pritisak od 200 mTorr. Ovo poređenje je prikazano na slici 3.2.11. Iako su kod strujnih signala razlike očekivano male, one su ipak jasno vidljive. Na svim harmonicima se puni simboli, kojima je predstavljeno rastojanje od 4 cm, nalaze iznad praznih simbola, kojima je označeno 7 cm. Kao posledicu ovakvog harmonijskog sastava, možemo očekivati nešto manju amplitudu, što se može i videti na slici 3.2.10 c). Razlika u frekventnom sastavu naponskih signala je predstavljena na slici 3.2.11 b). S obzirom na to da je

amplituda na rastojanju između elektroda od 7 cm nešto veća nego na 4 cm, može se očekivati da će intenziteti većine harmonika biti uglavnom veći upravo na 7 cm. Međutim, samo je osnovni harmonik intenzivniji na rastojanju od 7 cm dok su svi ostali, od prvih 6 prikazanih, praktično identični ili su intenzivniji oni koji su izmereni na međuelektrodnom rastojanju od 4 cm (puni simboli).

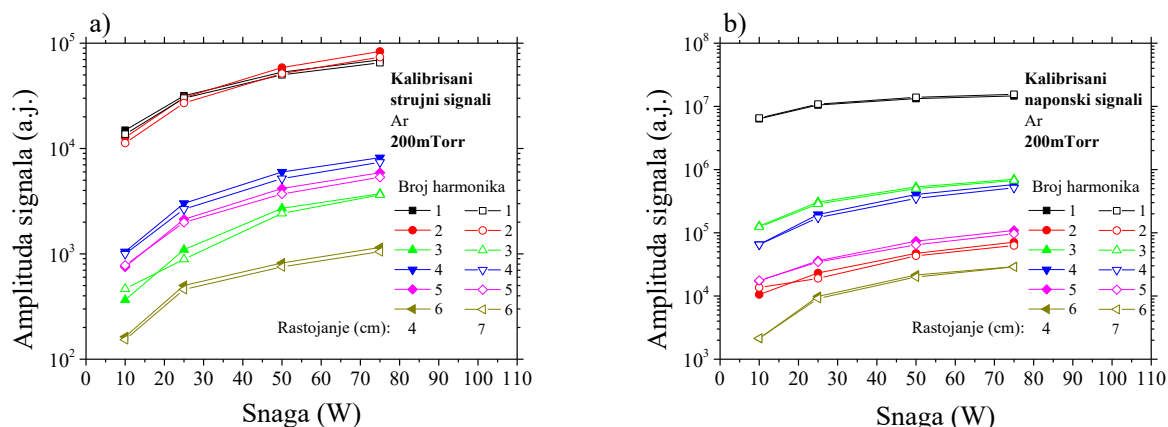

Slika 3.2.11 Poređenje frekventnog sastava a) strujnog i b) naponskog signala na dva različita međuelektrodna rastojanja na različitim snagama i pritisku od 200 mTorr.

Ukoliko se frekventni sastav strujnog signala uporedi sa autorima koji su ova merenja takođe radili u reaktoru plan paralelne geometrije [44], [138], jasno je da postoje sličnosti, tj. primetan je veoma intenzivan drugi harmonik. Imajmo u vidu da je tokom naših merenja u asimetričnom reaktoru (deo 2.2.1) osnovni harmonik bio dominantan kada je korišćena uzemljena elektroda velikog poluprečnika a da je intenzitet drugog harmonika bio značajno veći nakon postavljanja uzemljene elektrode manjeg poluprečnika. Ovim smo pokazali da se smanjivanjem odnosa uzemljene i napajane elektrode dobijaju signali koji sve više odstupaju od pravilnih sinusoida. I u slučaju plan paralelne geometrije elektroda do ovog odstupanja dolazi zbog toga što raste doprinos drugog harmonika.

Električne osobine svakog sistema najbolje je opisati preko strujno-naponske karakteristike, odnosno kroz zavisnost RMS vrednosti napona od struje. Na slici 3.2.12 je prikazana V-I karakteristika našeg plan paralelnog reaktora za pražnjenje u argonu. Crnom bojom su označene vrednosti dobijene na pritisku od 45 mTorr dok su crvenom bojom označene one koje su dobijene na pritisku od 200 mTorr. Svaka tačka predstavlja jedan par vrednosti struje i napona koji je dobijen za određenu nominalnu snagu napajачa, odnosno redom za 10, 25, 50 i 75 W. Na manjem pritisku su RMS vrednosti struje, u celokupnom opsegu snaga, bile između 0,3 i 0,84 A dok su se vrednosti napona kretale između 114 i 321 V i rasle su, kao i struja, sa povećanjem primenjene snage. Na većem pritisku je sistem radio na značajno nižim naponima ali su struje bile veće. Na 200 mTorr se struja kretala između 0,37 i 1.58 A dok je napon bio između 93 i 222 V. Na ovom mestu treba podsetiti da su u asimetričnom reaktoru, kada je bila korišćena uzemljena elektroda manjeg poluprečnika što je predstavljeno u glavi 2.2.1, dobijene slične zavisnosti RMS vrednosti struje i napona od pritiska. Odnosno, povećanje pritiska je dovelo do pada vrednosti napona ali i do povećanja vrednosti struje. To znači da smo pokazali da će, osim po svom harmonijskom sastavu, smanjivanjem odnosa površine uzemljene i napajane elektrode asimetrični sistem i po svojoj V-I karakteristici sve više da liči na sistem plan paralelne geometrije.. Na slici 3.2.12 su različita rastojanja između uzemljene i napajane elektrode označena kvadratima, 4 cm, i trouglovima, 7 cm. Kao što je pomenuto, promena rastojanja između elektroda ne dovodi do velike promene u osobinama reaktora što je vidljivo i preko V_{rms} - I_{rms} karakteristike sistema. Na 45 mTorr su naponi bili praktično identični na oba rastojanja dok je struja bila nešto veća kada je i rastojanje između elektroda bilo veće. Razlike su bile značajnije na manjim primenjenim snagama. Nešto veći efekat međuelektrodnog rastojanja na strujno naponsku

Plan-paralelno kapacitivno spregnuto pražnjenje

karakteristiku sistema je zabeležen na pritisku od 200 mTorr. Na tim uslovima pražnjenja je na većem rastojanju između elektroda zabeležena nešto veća RMS vrednost struje ali su izmereni naponi bili niži.

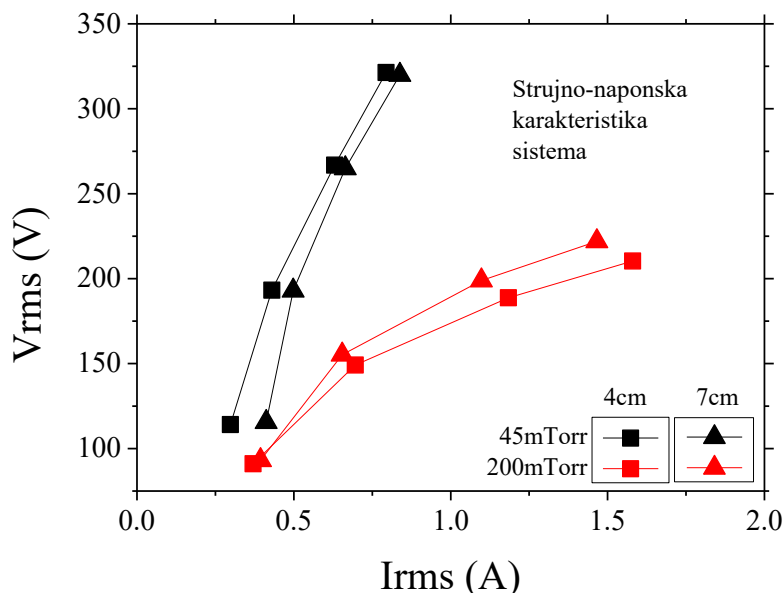

Slika 3.2.12 Strujno naponska karakteristika plan paralelnog izvora za pražnjenje u argonu za dva rastojanja između elektroda i dva pritiska. Crnom bojom je označen pritisak od 45 mTorr a crvenom od 200 mTorr, kvadratima je označeno rastojanje od 4 cm a trouglovima od 7 cm.

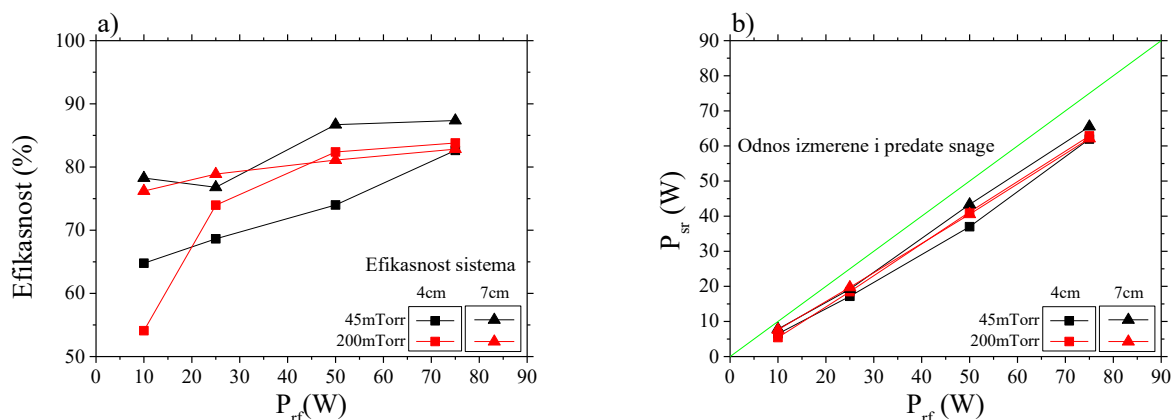

Slika 3.2.13 Efikasnost sistema predstavljena kao a) procenat nominalne snage (P_{rf}) i b) izmerena snaga (P_{sr}) u zavisnosti od nominalne snage generatora (P_{rf}).

Sposobnost sistema da isporučenu snagu preda pražnjenju smo predstavili na slici 3.2.13. Na slici 3.2.13 a) je efikasnost predstavljena kao odnos izmerene (P_{sr}) i nominalne snage (P_{rf}) preko procenta nominalne ($P_{sr}/P_{rf} \cdot 100\%$). Na slici 3.2.13 b), su ovi isti rezultati predstavljeni samo kao zavisnost izmerene (srednja vrednost) od nominalne snage. Iako je efikasnost sistema veća na većim nominalnim snagama, njena zavisnost od pritiska i rastojanja između napajane i uzemljene elektrode je komplikovana. Ipak, u najvećem broju uslova je sistem bio efikasniji na većem međuelektrodnom rastojanju i postigao je maksimum od 87 % na snazi od 75 W i pritisku od 200 mTorr. Sa druge strane,

minimalna efikasnost od svega 54 % je izmerena na pritisku od 45 mTorr, snazi od 10 W i međuelektrodnom rastojanju od 4 cm. Poređenjem sa strujno naponskim karakteristikama sistema (slika 3.2.12), može se izvući empirijski zaključak da će se snaga plazmi efikasnije predavati ukoliko se pražnjenja odvija na većim vrednostima struje i na manjim vrednostima napona.

Pored pražnjenja u argonu, električne osobine sistema su ispitivane i kad je kao radni gas korišćen azot. U ovom slučaju su eksperimenti rađeni na samo jednoj vrednosti pritiska, 100 mTorr, ali sa dva međuelektrodna rastojanja, od 4 i 7 cm. Dodatna razlika je i u vrednostima nominalne snage koja su, tokom pražnjenja u azotu, iznosila 25, 50, 100 i 200 W.

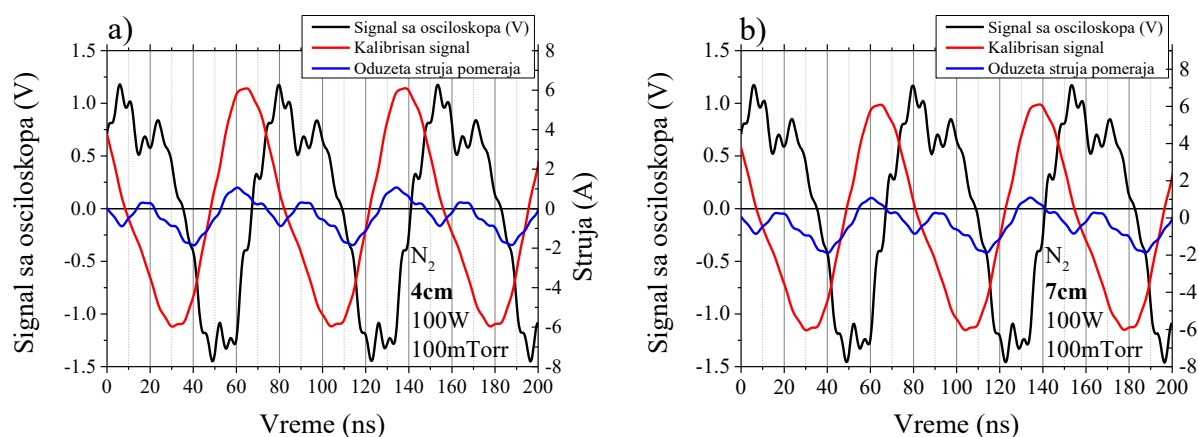

Slika 3.2.14 Primeri strujnih signala koji su dobijeni sa međuelektrodnim rastojanjem od a) 4 cm i b) 7 cm. Crnom bojom su označeni signali izmereni direktno sa osciloskopa (vrednosti su u voltima); strujni signali nakon množenja kalibracionim krivama (vrednosti u amperima) prikazani su crvenom bojom; nakon oduzimanja struje pomeraja – plavom bojom.

Korišćen je identičan postupak obrade signala kao i kada je radni gas bio argon. Na slici 3.2.14 su prikazani strujni signali u vremenskom domenu za dva različita međuelektrodna rastojanja i za nominalnu snagu generatora od 100 W. Signal koji je amplitudno i fazno korigovan, pre oduzimanja struje pomeraja, izgleda kao prilično pravilna sinusoida. Međutim, u signalima koji su dobijeni direktno sa strujne sonde i nakon oduzimanja struje pomeraja jasno je vidljiv doprinos viših harmonika. Takođe, kao i tokom pražnjenja u argonu, finalni strujni signal je većim svojim delom negativan.

Slično kao i tokom pražnjenja u argonu, vremenske zavisnosti naponskih signala su mnogo bliže sinusnom obliku signala, odnosno manje su vidljivi doprinosi viših harmonika. One su predstavljene na slici 3.2.15 za dva rastojanja između napajane i uzemljene elektrode. Kod signala koji su dobijeni direktno sa sonde se vidi da doprinos drugog harmonika neće biti značajan, jer ne postoje dvostruki maksimumi i minimumi, ali se vidi da doprinosi sa viših frekvencija neće biti zanemarljivi. Međutim, oblik signala koji se dobija nakon fazne i amplitudne korekcije izgleda kao skoro savršena sinusoida.

Plan-paralelno kapacitivno spregnuto pražnjenje

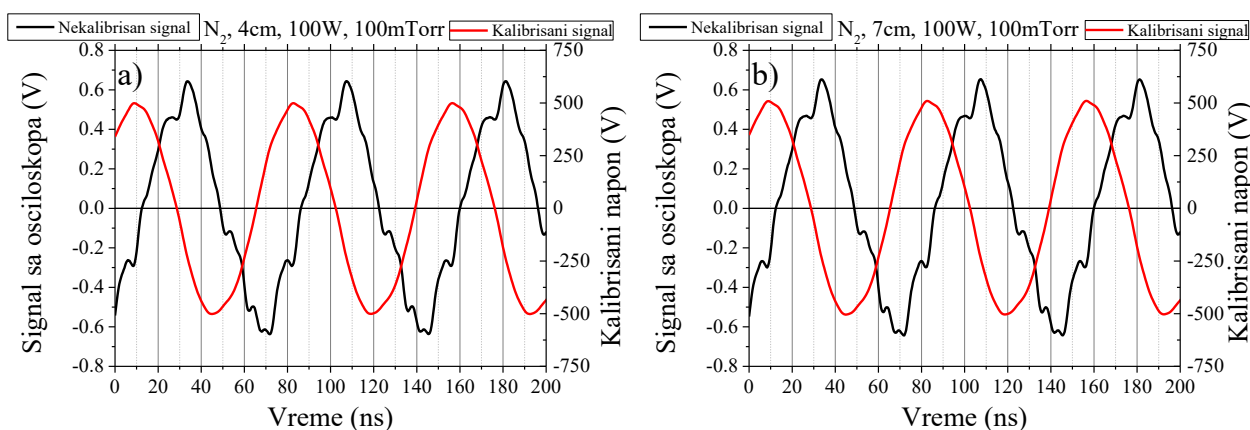

Slika 3.2.15 Primeri naponskih signala koji su dobijeni sa međuelektrodnim rastojanjem od a) 4 cm i b) 7 cm. Crnom bojom su obeleženi signali koji su dobijeni direktno sa osciloskopa dok su crvenom bojom obeleženi signali nakon množenja kalibracionim krivama.

Frekventni sastav strujnog signala za nominalnu snagu pražnjenja od 100 W i za dva među elektrodna rastojanja je prikazan na slici 3.2.16. Na slikama a) i c) je prikazan sastav signala koji je dobijen direktno sa osciloskopa i signala koji pomnožen kalibracionim krivama, dok je na slikama b) i d) prikazano poređenje signala koji su amplitudno i fazno korigovani i nakon što je oduzeta struja pomeraja. Na ovim uslovima pražnjenja (100 mTorr, 100 W) su, u finalnom strujnom signalu, amplitude osnovnog i drugog harmonika praktično jednake, na obe rastojanja između napajane i uzemljene elektrode. Drugi harmonik je za red veličine manji ali su treći i četvrti oko 6 puta manji od osnovnog (i drugog) zbog čega su, pored dvostrukih minimuma i maksimuma, vidljive i dodatne nepravilnosti u strujnom signalu.

Plan-paralelno kapacitivno spregnuto pražnjenje

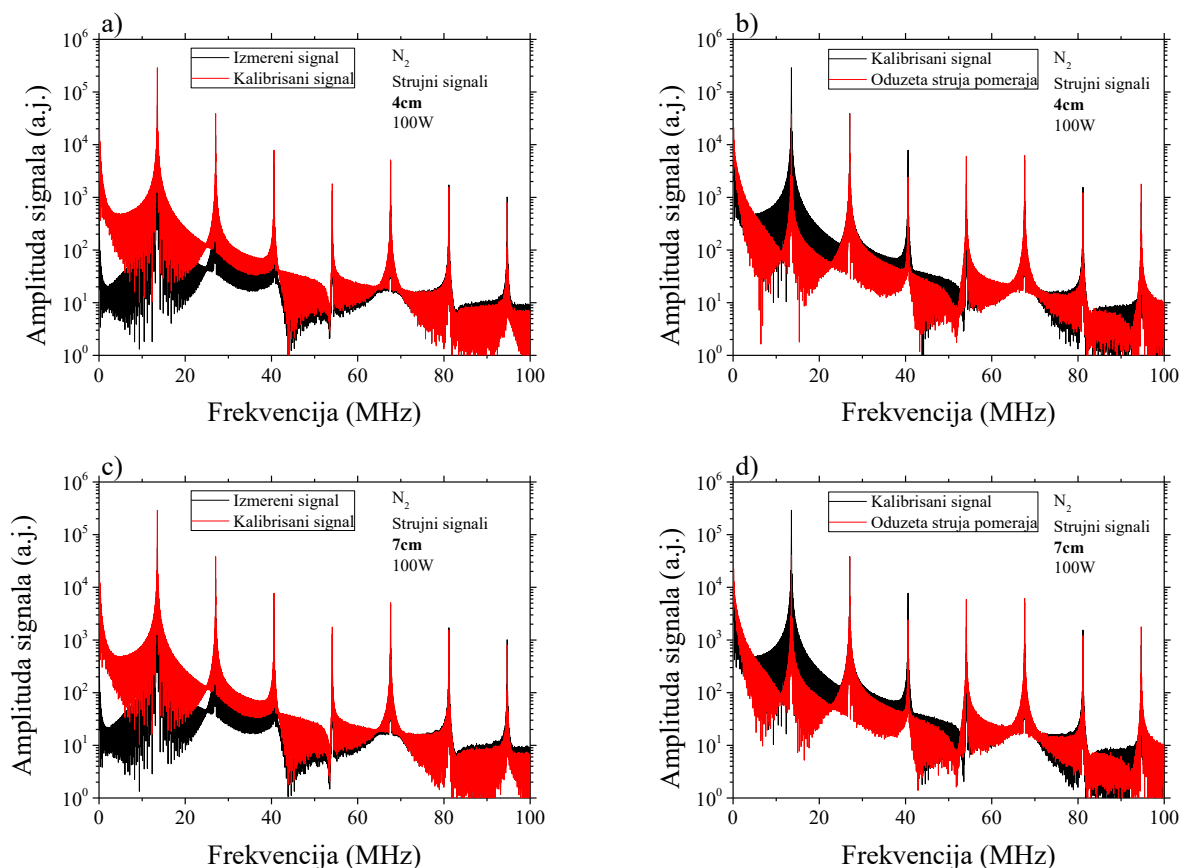

Slika 3.2.16 Zavisnost amplitude strujnih signala od frekvencije za međuelektrodno rastojanje od 4 cm (a i b) i 7 cm (c i d), signala sa osciloskopa i posle množenja kalibracionim krivama (a i c) i nakon oduzimanja struje pomeraja (b i d).

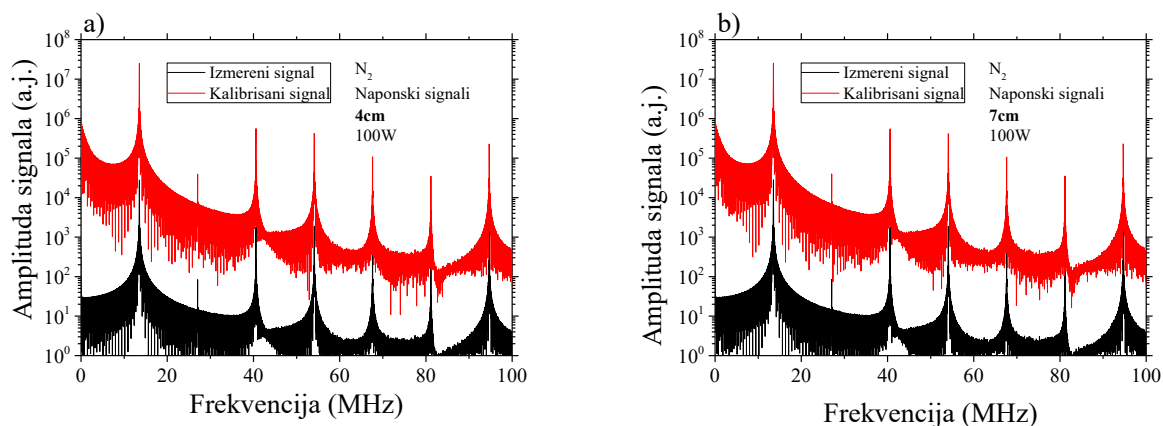

Slika 3.2.17 Zavisnost amplitude naponskog signala od frekvencije za međuelektrodno rastojanje od a) 4 cm i b) 7 cm. Signal dobijen sa osciloskopa je obeležen crnom bojom dok je signal pomnožen kalibracionim krivama obeležen crvenom bojom.

Zavisnost amplitude naponskog signala od frekvencije je prikazana, za dva međuelektrodna rastojanja, na slici 3.2.17. Crnom bojom je označen signal koji je dobijen direktno sa naponske sonde dok je crvenom bojom označen amplitudno i fazno korigovan signal. Na oba rastojanja između elektroda je, kod obrađenog signala, intenzitet drugog harmonika tri reda veličine manji od osnovnog dok su 3.-i i 4.-i harmonici po intenzitetu za dva reda veličine manji. Imajući ovo u vidu je jasno da

Plan-paralelno kapacitivno spregnuto pražnjenje

vremenski oblik ovakvog signala treba da izgleda skoro kao savršena sinusoida što je i prikazano na slici 3.2.15.

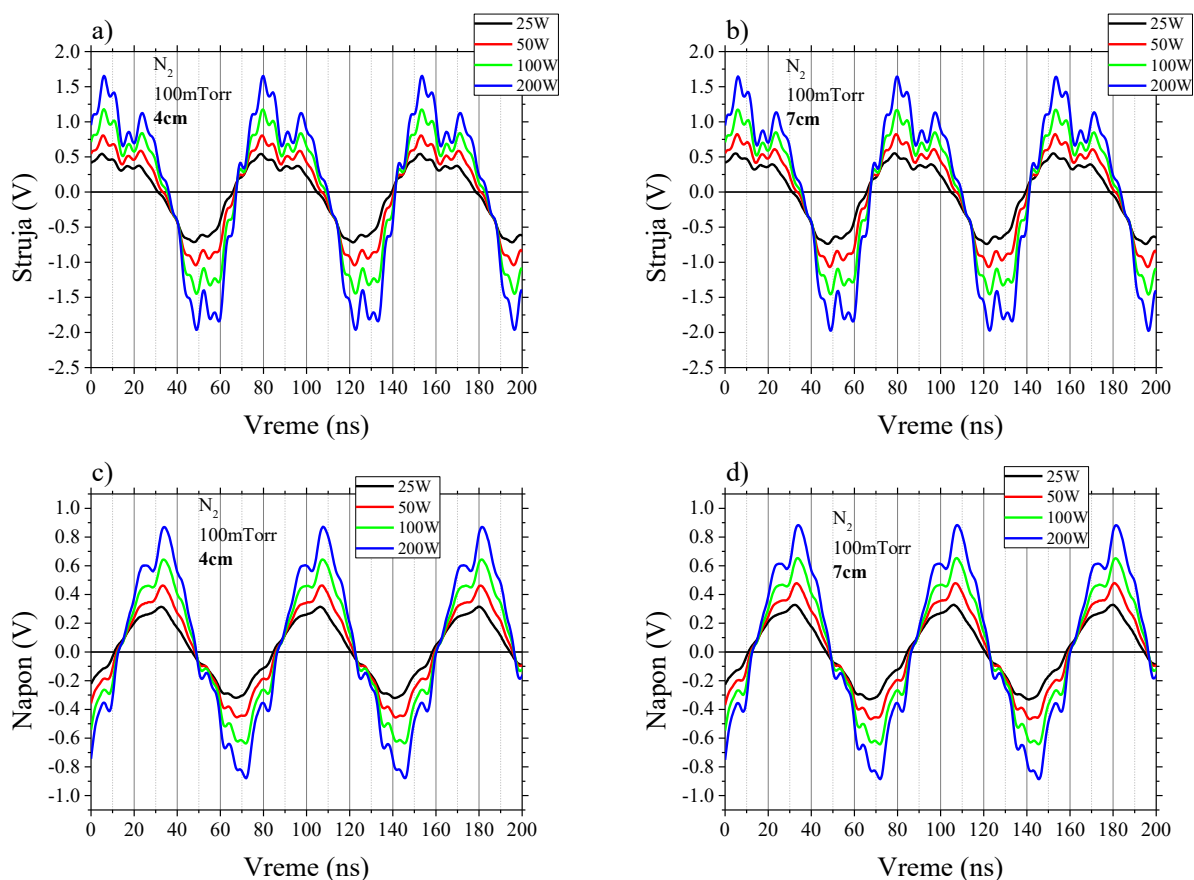

Slika 3.2.18 Poređenje nekalibrisanih strujnih (gore) i naponskih signala (dole) u zavisnosti od primenjene snage za rastojanje između elektroda od 4 cm (a) i c) i 7 cm (b) i d).

Zavisnost signala koji su dobijeni direktno sa sonde, u vremenskom domenu, od primenjene snage je prikazana, i za struju i za napon, na slici 3.2.18. Kao i u svim prethodnim merenjima, efekat viših harmonika je jasno vidljiv na nekalibrisanim signalima a njihova amplituda će da raste sa povećanjem primenjene snage. Naponske krive su nešto pravilnijeg oblika a efekat rastojanja između napajane i uzemljene elektrode, u ovim rezultatima, nije vidljiv.

Efekat nominalne snage na oblik vremenske zavisnosti obrađenih strujnih i naponskih signala je, za oba međuelektrodna rastojanja, prikazan na slici 3.2.19. Iako su nakon amplitudne i fazne korekcije strujni signali nešto pravilniji, oni ipak izgledaju, slično kao i kod pražnjenja u argonu, kao superpozicija signala različitih frekvencija. Velika razlika je što je u azotnom pražnjenju, čak i kod signala u vremenskom domenu, vidljivo da će pored drugog harmonika veliki efekat imati i komponente signala na višim frekvencijama. Sa druge strane, obrađeni naponski signali, na oba rastojanja između elektroda i na svim primenjenim snagama, izgledaju kao gotovo savršene sinusoide.

Plan-paralelno kapacitivno spregnuto pražnjenje

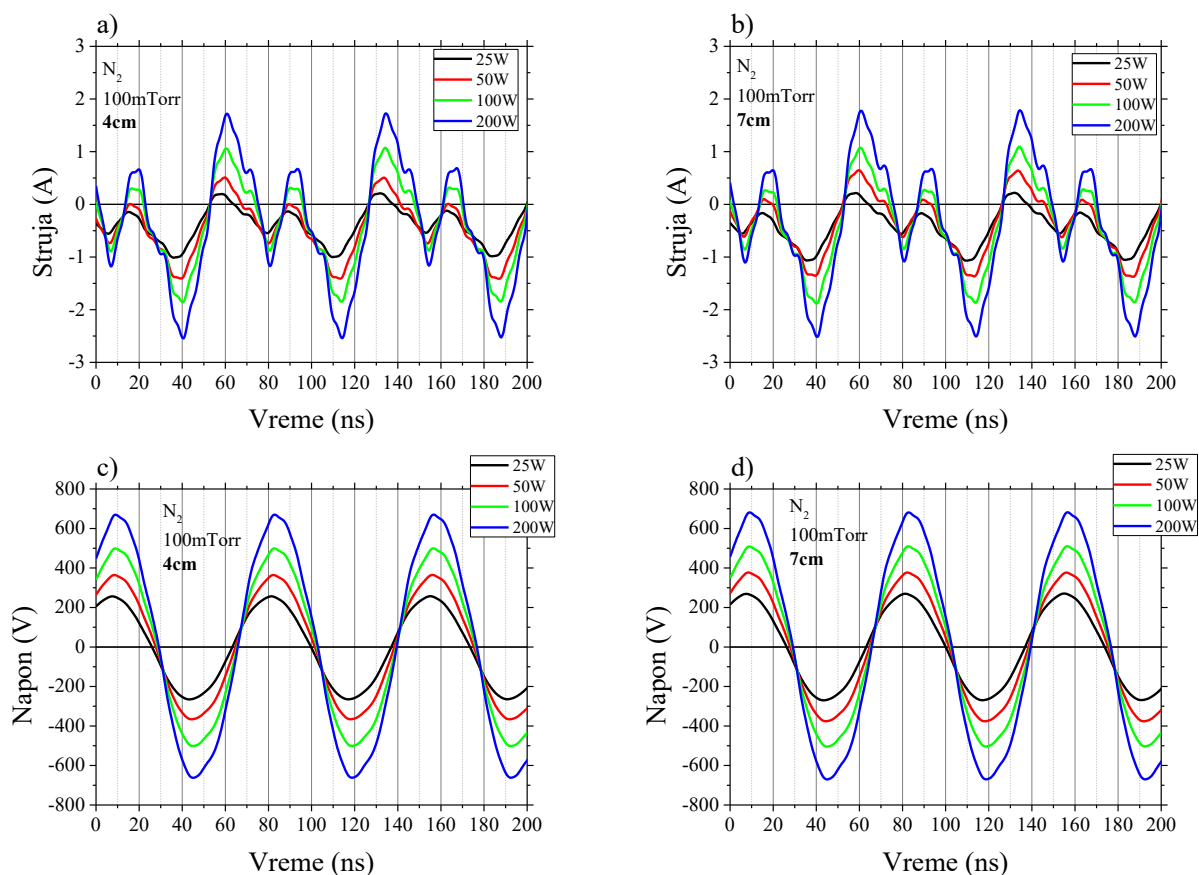

Slika 3.2.19 Poređenje obrađenih strujnih i naponskih signala u zavisnosti od primenjene snage za rastojanje između elektroda od 4 cm (a) i c)) i 7 cm (b) i d)).

Zavisnost frekventnog sastava strujnog i naponskog signala od nominalne snage pražnjenja je, za međuelektrodno rastojanje od 4 cm, prikazano na slici 3.2.20. Nekalibrisani signali su prikazani na slikama a) i b), dok se korigovani signali nalaze na slikama c) i d). Iako je kod neobrađenog strujnog signala dominantan osnovni harmonik, intenzitet drugog svega tri i po puta manji. Međutim, intenziteti 3.-eg i 5.-og harmonika iznose oko 10 % osnovnog što u vremenskom domenu dovodi do „nazubljenosti“ signala. Kod neobrađenog naponskog signala je takođe dominantan osnovni harmonik ali je karakteristično da je, kao i kod argonskog pražnjenja, intenzitet drugog harmonika najslabiji, čak četiri reda veličine u odnosu na osnovni. Do vidljivih deformacija dovodi prisustvo viših harmonika, najviše trećeg i četvrtog, koji imaju gotovo identične signale čiji intenziteti iznosi nešto manje od 10 % intenziteta signala na 13,56 MHz.

Razlog za postojanje dvostrukih minimuma i maksimuma kod obrađenih strujnih signala leži u činjenici da su, nakon obrade, intenziteti osnovnog i drugog harmonika praktično jednaki. Postojanje dodatnih nepravilnosti uzrokovano je veoma intenzivnim četvrtim i petim harmonikom, koji su svega 6 puta manji od osnovnog i međusobno su praktično jednaki. Pogledom na frekventni sastav obrađenih naponskih signala nam postaje jasno zašto je njihov oblik, u vremenskom domenu, praktično savršena sinusoida. Intenzitet osnovnog harmonika je čak dva reda veličine veći od intenziteta prvog sledećeg harmonika, što je u našem, slučaju bio treći. Drugi harmonik je, i nakon obrade, čak 3 veličine manje intenzivan od osnovnog.

Plan-paralelno kapacitivno spregnuto pražnjenje

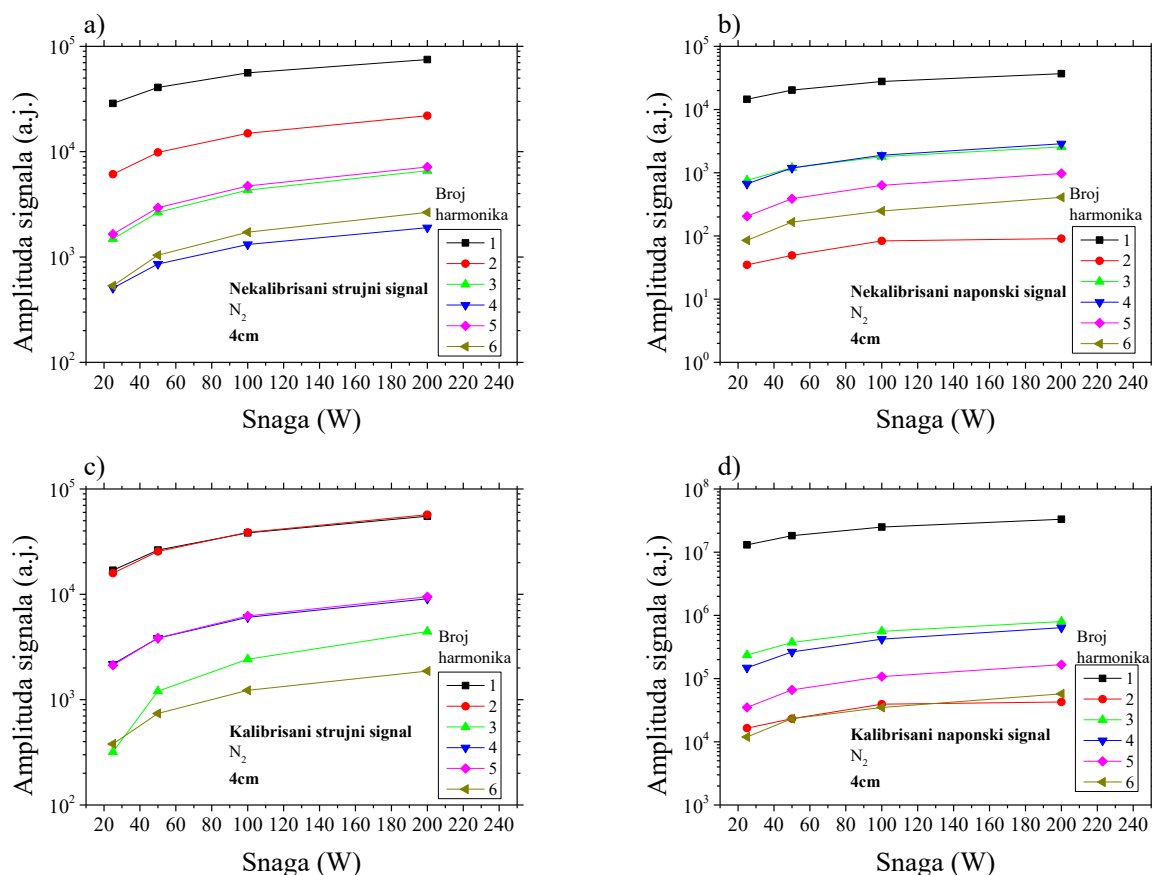

Slika 3.2.20 Amplitude prvih 6 harmonika, strujnih (a) i c)) i naponskih (b) i d)) signala koji su dobijeni direktno sa osciloskopa (a) i b)) i nakon obrade (c) i d)) sa rastojanjem između elektroda od 4 cm.

Promena frekventnih sastava signala u zavisnosti od nominalne snage generatora je, za rastojanje između elektroda od 7 cm, predstavljena na slici 3.2.21 i može da se primeti da suštinska razlika u odnosu na međuelektrodno rastojanje od 4 cm ne postoji. Kod nekalibrisanog strujnog signala je osnovni harmonik između tri i pet puta intenzivniji od drugog, dok su intenziteti 4.-og i 5.-og praktično jednaki i iznose oko 10% intenziteta osnovnog. U neobrađenom strujnom signalu, i na ovom rastojanju između elektroda, ubedljivo dominira osnovni harmonik čiji je intenzitet 15 puta veći od prvog sledećeg dok je drugi harmonik najslabiji, odnosno tri reda veličine manji u odnosu na osnovni. Nakon amplitudne i fazne korekcije se kod strujnog signala skoro izjednačavaju intenziteti osnovnog i drugog harmonika, ali je razlika među njima, pogotovo na malim nominalnim snagama, nešto jasnija nego na manjem rastojanju između elektroda. Intenziteti 4.-og i 5.-og harmonika su praktično jednaki i od osnovnog su manji od 6 do 10 puta. Kod obrađenih naponskih signala je, takođe, dominantan osnovni harmonik. On je kao i tokom merenja na manjem rastojanju između elektroda od, po intenzitetu, prvog sledećeg harmonika 2 reda veličine intenzivniji.

Plan-paralelno kapacitivno spregnuto pražnjenje

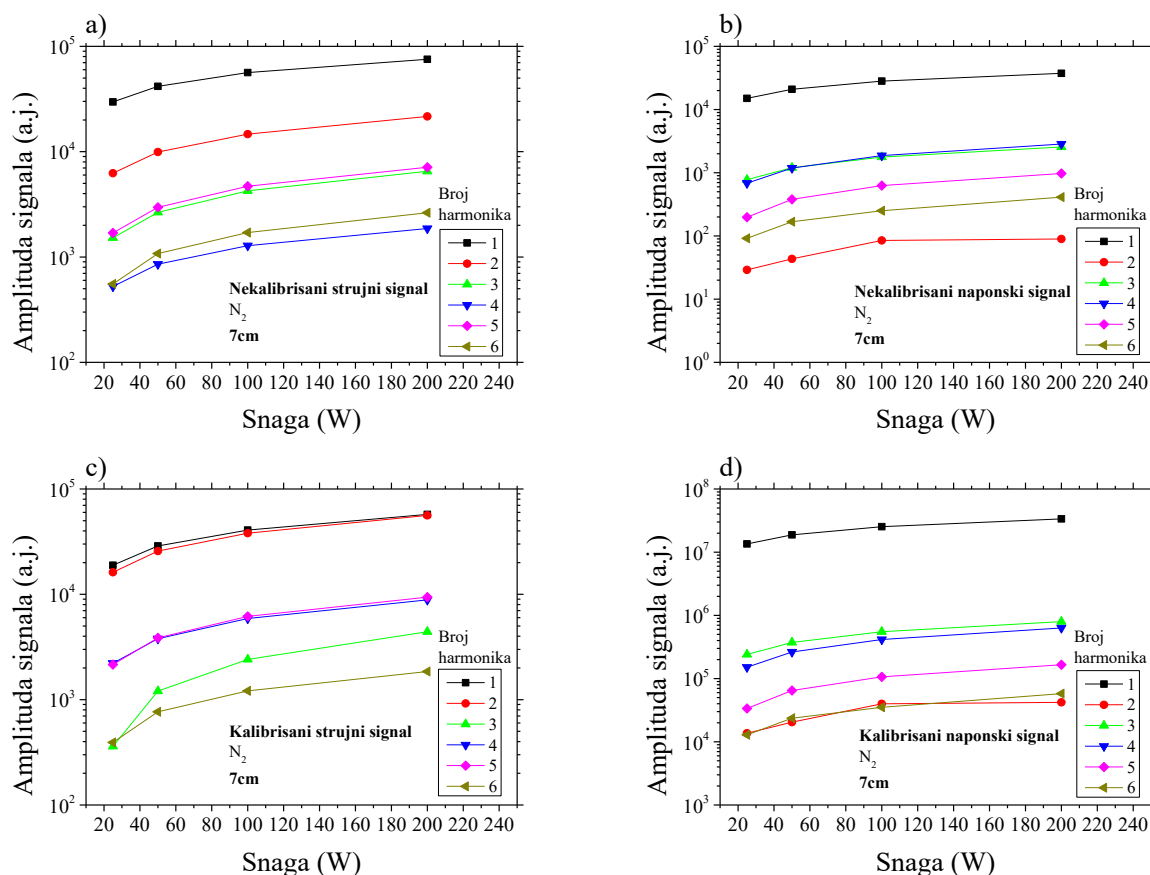

Slika 3.2.21 Amplitude prvih 6 harmonika, strujnih (a) i c)) i naponskih (b) i d)) signala koji su dobijeni direktno sa osciloskopa (a) i b)) i nakon obrade (c) i d)) sa rastojanjem između elektroda od 7 cm.

Da promena rastojanja između napajane i uzemljene elektrode, u ovom opsegu parametara, ne dovodi do bitnih promena u električnim osobinama sistema može da se vidi i na slici 3.2.22 na kojoj je predstavljeno poređenje obrađenih strujnih i naponskih signala na dva različita međuelektrodna rastojanja, od 4 i 7 cm, ali na istoj nominalnoj snazi pražnjenja, od 200 W. Strujni signali su praktično identični uz jedinu razliku što je signal dobijen na rastojanju od 7 cm malo „pozitivniji“, odnosno pomeren je ka većem vrednostima. Razlika je manja od jednog procenta i može da bude rezultat eksperimentalne greška. Slična je situacija kod naponskih signala koji su takođe praktično identični ali je amplituda na 7 cm par procenata veća.

Plan-paralelno kapacitivno spregnuto pražnjenje

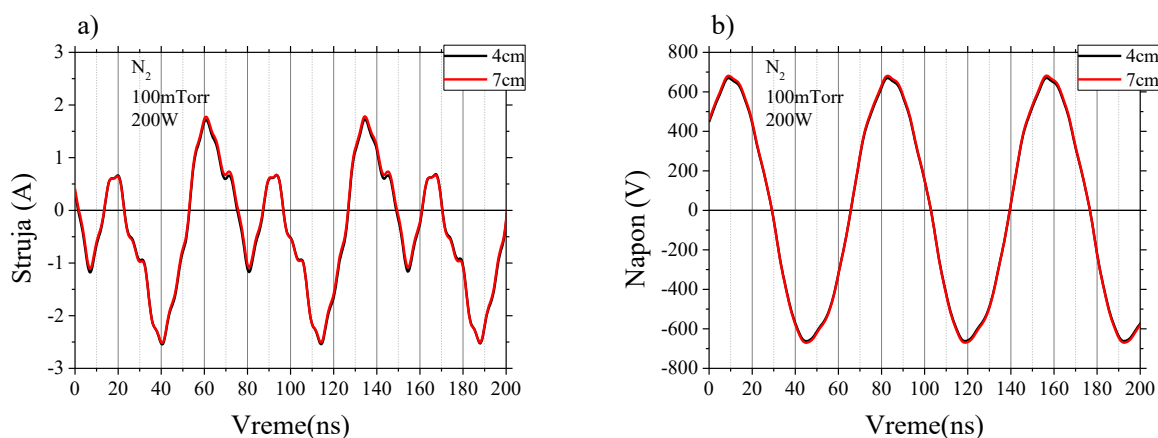

Slika 3.2.22 Efekat promene međuelektrodnog rastojanja na kalibrisane a) strujne i b) naponske signale pri nominalnoj snazi pražnjenja od 200 W.

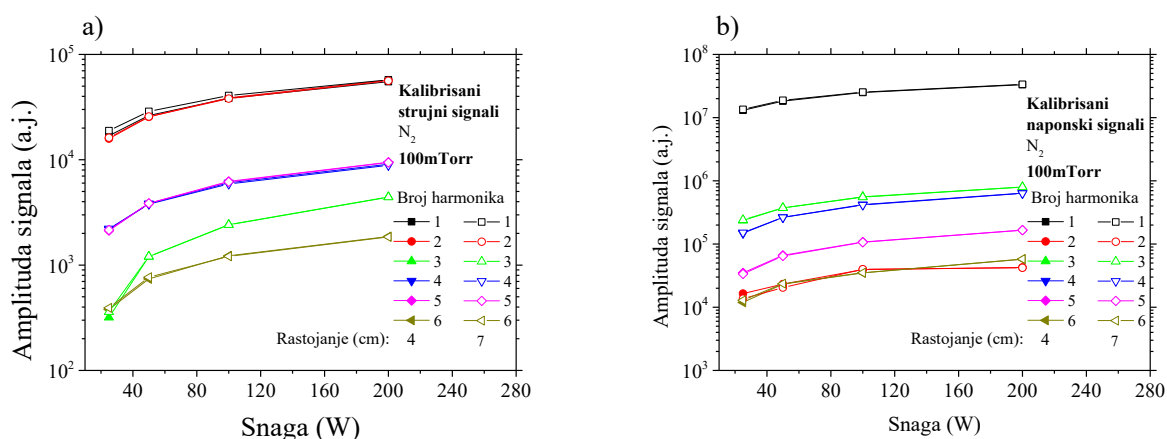

Slika 3.2.23 Poređenje frekventnog sastava a) strujnog i b) naponskog signala na dva različita međuelektrodna rastojanja.

Kao dodatnu proveru slabe zavisnosti električnih osobina reaktora od rastojanja između napajane i uzemljene elektrode smo na slici 3.2.23 direktno uporedili frekventne sastave obrađenih strujnih i naponskih signala. Na skoro svim harmonicima i svim snagama poklapanja su gotovo savršena. Određena razlika postoji u intenzitetu osnovnog harmonika strujnog signala na manjim snagama, kada je nešto veći onaj koji je dobijen tokom merenja na rastojanju od 7 cm. Kod naponskog signala, takođe, postoje male razlike u intenzitetu osnovnog harmonika, koje su izraženije na malim nominalnim snagama generatora. Imajući ovo u vidu, možemo da očekujemo nešto veću efikasnost sistema kada je rastojanje među elektrodama bilo veće, jer su napajani istom nominalnom snagom a dobijene su nešto veće RMS vrednosti struje i napona.

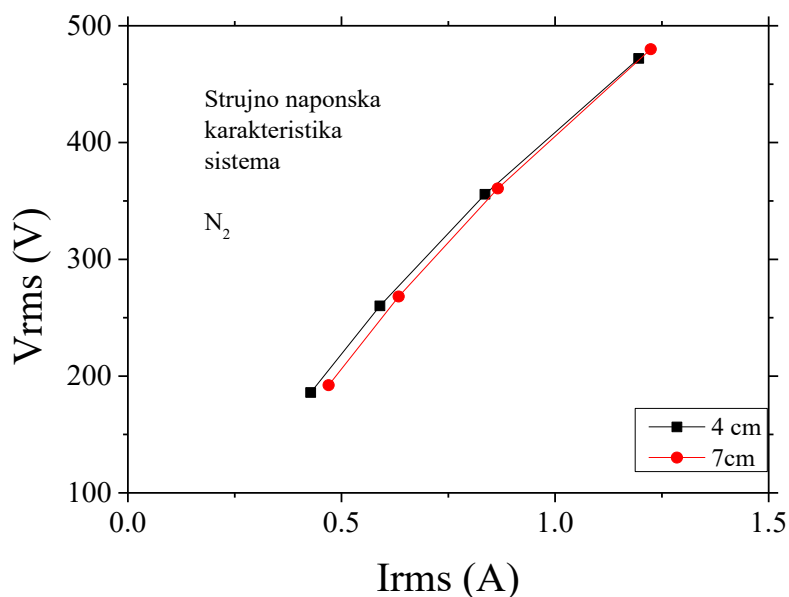

Slika 3.2.24 Strujno naponska karakteristika komore sa plan paralelnim elektrodama za pražnjenje u azotu za dva rastojanja između elektroda i $p=100\text{mTorr}$.

Strujno-naponske karakteristike sistema za pražnjenje u azotu je prikazana na slici 3.2.24 za dva međuelektrodna rastojanja. Kao i prethodnim slučajevima, svaka tačka predstavlja jedan par RMS vrednosti struje i napona a koje su dobijene na snagama od 25 do 200 W nominalne snage. Iako ove vrednosti ne možemo direktno da poredimo sa onima koje su dobijene tokom pražnjenja u argonu, jer su merenja rađena i na drugom pritisku i na drugačijim snagama, možemo ipak da povučemo određene paralele. Naime tokom pražnjenja u argonu je pokazano da povećanje pritiska dovodi do povećanja vrednosti struje. Na pritisku od 200 mTorr Ar, koji duplo veći od pritiska na kome su rađena merenja u azotu, su postignute struje koje su oko 30 procenata veće. U poređenju sa merenjima u argonskom pražnjenju na 45 mTorr, struje u azotu (na 100 mTorr) su bile oko 40 % veće. Poređenjem struja koje su dobijene na nominalnoj snazi pražnjenja od 50 W, što je snaga na kojoj je mereno u oba gasa i na sva tri pritiska, se primećuje da su dobijene skoro iste vrednosti struje za argonsku plazmu na 45 mTorr i azotnu plazmu na 100 mTorr, oko 0,6 A. Iz ovoga možemo da donesemo zaključak da bi tokom pražnjenja na sličnim pritiscima i snagama moglo da se očekuje da će struje u argonskoj plazmi biti veće u odnosu na one u azotnoj. Sa druge strane, tokom pražnjenja na 50 W, su dobijene gotovo identične RMS vrednosti napona u azotu na 100 mTorr i argonu na 45 mTorr (oko 260 V RMS). Na većem rastojanju su, na svim snagama postignute nešto veće vrednosti struje i par procenata veće vrednosti napona.

Plan-paralelno kapacitivno spregnuto pražnjenje

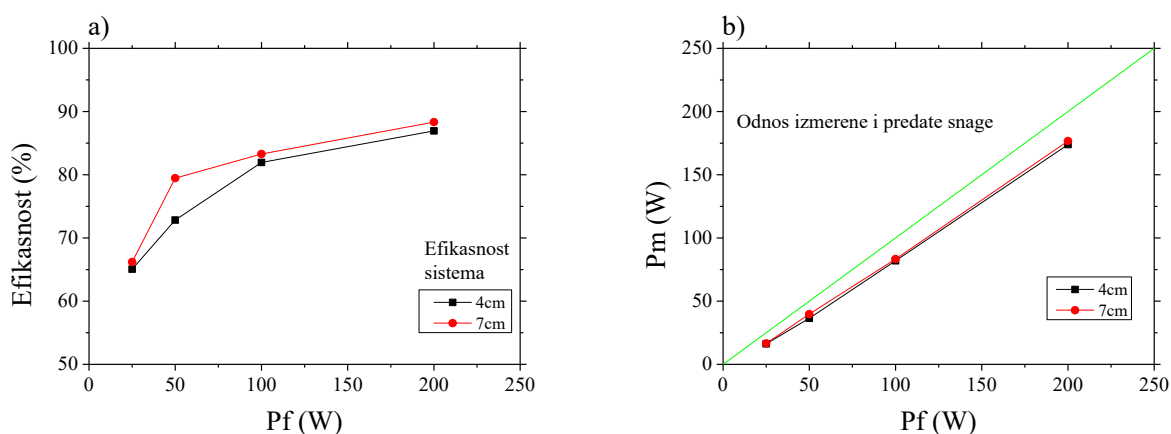

Slika 3.2.25 Efikasnost sistema predstavljena kao a) procenat nominalne snage (P_f) i b) izmerena snaga (P_m) u zavisnosti od nominalne snage generatora (P_f).

Efikasnost predaje snage ovog sistema tokom pražnjenja u azotu je predstavljena na slici 3.2.25. Kao što smo i očekivali iz posmatranja frekventnog sastava strujnog i naponskog signala, ali i iz strujno naponske karakteristike, efikasnost je nešto veća na većem rastojanju između uzemljene i napajane elektrode. Kao i tokom pražnjenja u argonu, ali i u asimetričnom reaktoru, veće efikasnosti su postignute na većim nominalnim snagama. U uslovima koje smo ispitali, efikasnost plan paralelnog reaktora tokom pražnjenja u azotu se kreće od 65 %, na snazi od 25 W i rastojanju od 4 cm, do 88 %, na snazi od 200 W i međuelektrodnim rastojanjem od 7 cm.

3.2.2. OPTIČKA EMISIONA SPEKTROSKOPIJA

Na slici 3.2.26 prikazan je kompletan spektar zračenja dobijen iz azotne plazme na pritisku od 100 mTorr sa primenjenom snagom od 50 W. Spektar pokriva oblasti od bliskog UV do bliskog IC zračenja, odnosno od 300 do 800 nm. U prikazanom spektru nalaze se samo trake koje pripadaju azotu [188], [189]. Mogu da se primete dve trake molekula, odnosno prva i druga pozitivna traka azota, i jedna traka N_2^+ jona, prva negativna. S obzirom na to da nisu primećene trake ili linije drugih gasova koje se nalaze u vazduhu, poput kiseonika, možemo da kažemo da se u komori nalazi zanemarljivo malo nečistoća čije je poreklo okolna atmosfera. Pre svakog merenja, nakon zatvaranja komore, pritisak u njoj je spuštán do osnovnog pritiska od svega nekoliko mTorr pre nego što je u nju upuštán radni gas.

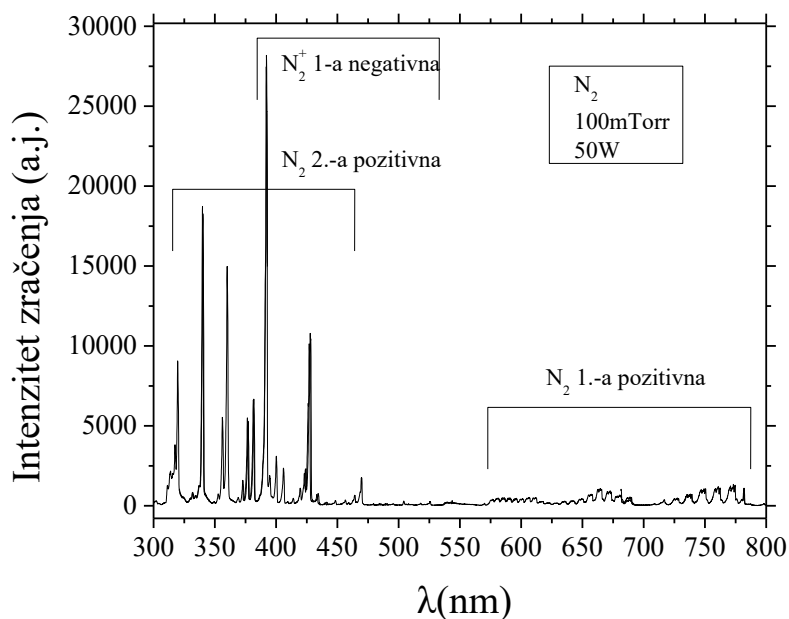

Slika 3.2.26 Spektar zračenja iz pražnjenja (100 mTorr, 50 W, N_2) sa naznačenim molekulskim trakama azota (1.-a i 2.-a pozitivna) i trkama N_2^+ jona (1.-a negativna).

S obzirom na to da je ovaj reaktor korišćen za tretmane nekoliko različitih vrsta uzoraka, nametnulo se pitanje da li se optičkim metodama može ispitati na koji način prisustvo uzoraka u pražnjenju utiče na samu plazmu, tj. da li je moguće u emisionom spektru uočiti promene koje potiču od interakcije pobuđenih čestica sa površinom uzorka? Pokazano je u literaturi da na površini celuloznog tipa materijala dolazi do znatnog povećanja koncentracije azota nakon tretmana u azotovoj plazmi na niskom pritisku [190]. Pretpostavljeni mehanizmi podrazumevaju interakciju sa molekulima na površini, raskidanje spoljašnjih veza i inkorporiranje azota iz plazme u polisaharidni lanac. Azot koji učestvuje u ovim procesima svakako dolazi iz plazme ali je dilema bila da li se ove interakcije mogu uočiti kroz promene u emisionom spektru pobuđenih vrsta u plazmi. Kako su ukupni efekti tretmana plazmom na površinu uzorka u sekundnom vremenskom domenu, tj. par desetina sekundi, to bi za eventualne reakcije koje bi mogle da utiču na osobine plazme takođe bio značajan isti domen. Prema tome usled velike površine uzorka na kojoj dolazi do interakcije, za praćenje potencijalnog fenomena dovoljna je vremenska rezolucija reda veličine par sekundi ili desetina sekundi.

Snimanje optičkih spektara o kojima će biti reči u ovom delu disertacije je rađeno korišćenjem režima kinetičke serije. Da podsetimo, na ovaj način je moguće da se tokom jednog definisanog perioda napravi zadat broj snimaka u jednakim vremenskim razmacima – kinetička serija, što znači da je moguće da se tokom tog perioda prati njihova promena odnosno njihova evolucija. Jedan snimak kinetičke serije, odnosno snimljeni spektar u odgovarajućem vremenskom trenutku, urađen je u režimu akumulacija, tj. dobijen je usrednjavanjem nekoliko snimaka sa kratkom ekspozicijom. Ukupno vreme snimanja je bilo jednako vremenu tretmana. S obzirom na to da se i početak snimanja i početak tretmana, odnosno uključivanje pražnjenja, započinju ručno, prvi snimak kinetičke serije zapravo odgovara prelaznom režimu u okviru kog se pražnjenje tek uspostavlja. Tokom snimanja koja su trajala 5 minuta novi spektar je prikupljan na svakih 15 s dok je za dvominutna pražnjenja pravljen na svakih 5 s. Spektri su snimani u opsegu talasnih dužina između 260 i 330 nm sa centralnom talasnom dužinom $\lambda_c = 300 \text{ nm}$. Tokom ovih snimanja gornji deo prozora je bio

Plan-paralelno kapacitivno spregnuto pražnjenje

pokriven kako bi se zračenje dominantno skupljalo iz zapremine neposredno iznad uzemljene elektrode, odnosno tretiranog uzorka.

Na početku istraživanja za praćenje vremenskog razvoja zračenja iz plazme su odabrane dve azotove linije druge pozitivne trake ($C^3\Pi_u-B^3\Pi_g$): čelo trake na 337,13 nm i linija prelaza (1,0) na 315,93 nm.

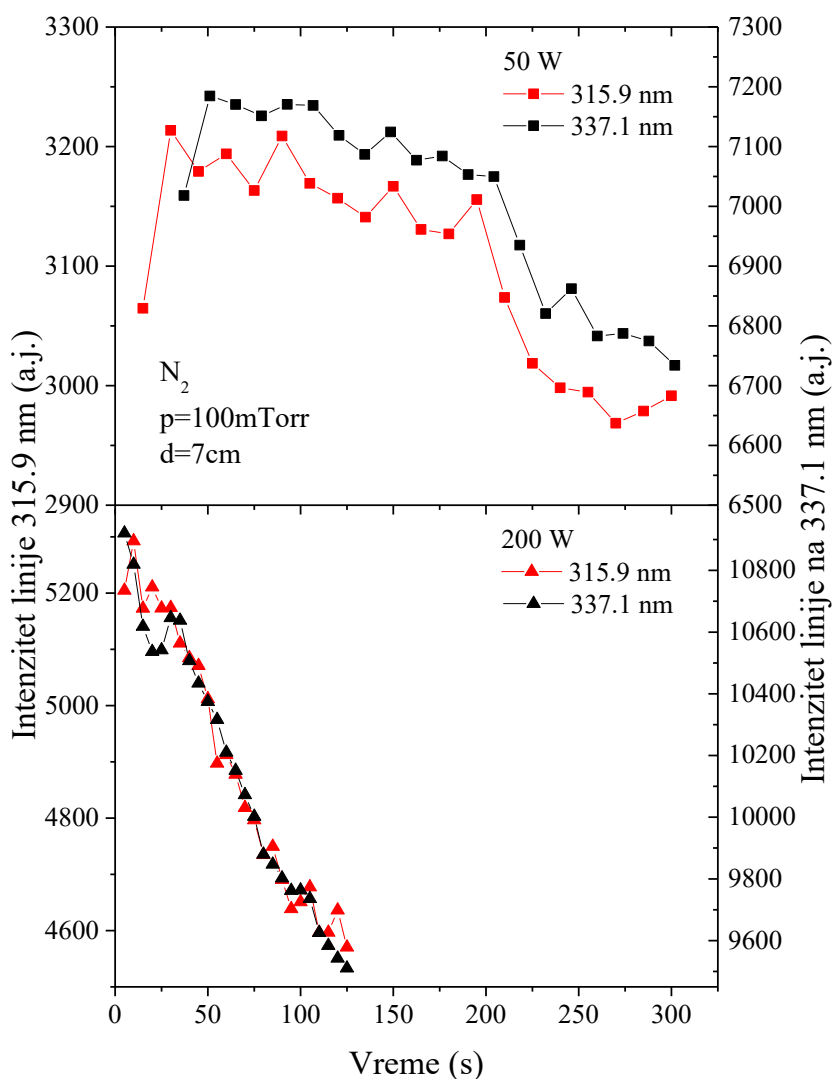

Slika 3.2.27 Vremenska evolucija azotovih linija na 315, 9 nm (leva skala) i 337,1 nm (desna skala) tokom tretmana pamučnog uzorka na nominalnoj snazi od 50 W (gore) i 200 W (dole) Međuelektrodno rastojanje je 7 cm a pritisak 100 mTorr.

Na slici 3.2.27 je prikazana vremenska evolucija linija na 315,9 nm i 337,1 nm tokom pražnjenja kada je u komori bio prisutan pamučni uzorak. Merenja su napravljena na pritisku od 100 mTorr sa međuelektrodnim rastojanjem od 7 cm. Na gornjem delu slike je predstavljena evolucija linija kada je primenjena snaga iznosila 50 W dok su rezultati na donjem delu slike napravljeni na snazi pražnjenja od 200 W. Snimanje na manjoj snazi je trajalo 5 min (300 s), dok je prikupljanje podataka tokom snimanja na većoj snazi bilo skraćeno na 125 s. Može da se primeti da ove dve linije evoluiraju na praktično identičan način, osim što su im apsolutne vrednosti različite. Zbog toga će u

daljim razmatranjima biti predstavljena samo jedna od njih. Izabrana je linija od 337,1 nm jer je zračenje na ovoj talasnoj dužini duplo intenzivnije.

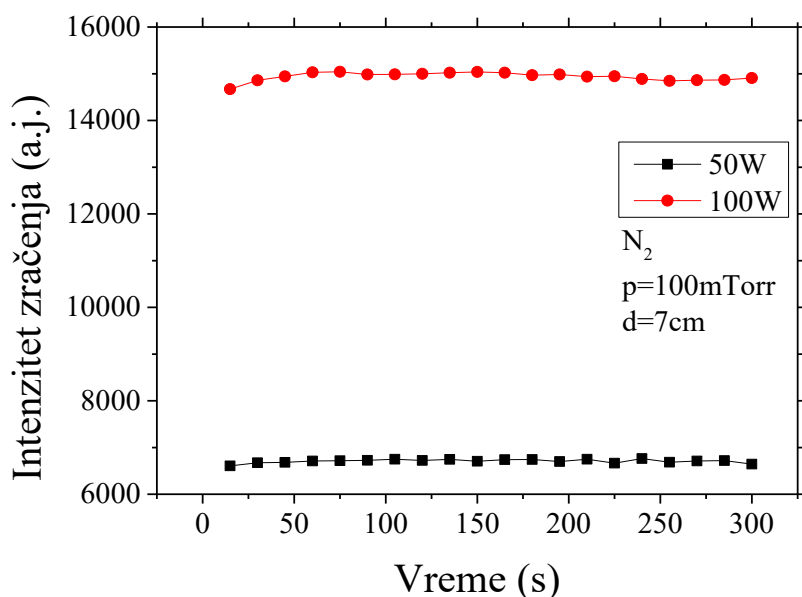

Slika 3.2.28 Evolucija linije na 337,1 nm snimljena u azotnom pražnjenju, bez uzorka u komori, na pritisku od 100 mTorr i sa međuelektrodnim rastojanjem od 7 cm sa primenjenom snagom od 50 W (crni simboli) i 100 W (crni simboli)

Promena intenziteta azotove linije na 337,1 nm za dve različite snage u komori bez uzorka je prikazana na slici 3.2.28. Pritisak je bio podešen na 100 mTorr a međuelektrodno rastojanje na 7 cm. Na obe snage, od 50 i 100 W, će emisija tokom perioda od 5 minuta ostati praktično konstanta. Može, ipak, da se primeti blagi porast intenziteta u prvih nekoliko snimaka kinetičke serije.

Sa slika 3.2.27 i 3.2.28 vidi se razlika u ponašanju intenziteta emisije azotove linije na 337,1 nm u pražnjenju sa i bez pamučnog uzorka. Maksimalna emisija u slučaju sa prisutnim uzorkom u komori postiže se neposredno nakon početka snimanja kinetičke serije, odnosno nakon 45 s. To znači da će u tom trenutku, tokom tretmana, u komori biti najveća koncentracija emitera odnosno pobuđenih molekula azota.

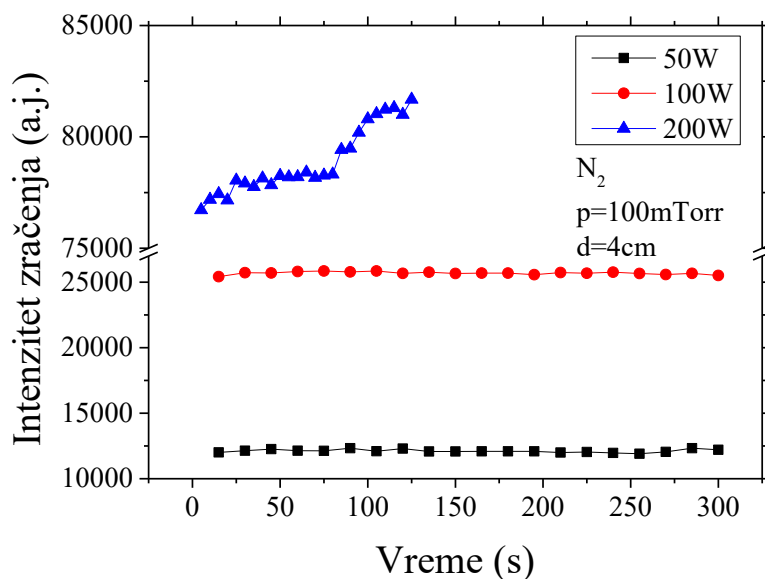

Slika 3.2.29 Evolucija linije na 337.1 nm snimljena u azotnom pražnjenju na pritisku od 100 mTorr i sa među elektrodnim rastojanjem od 4 cm sa primenjenim snagama od 50 W (crni simboli), 100 W (crni simboli) i 200 W (plavi simboli). Snimanje su vršena bez uzorka u komori.

S obzirom na to da u ovom reaktoru imamo mogućnost promene rastojanja između napajane i uzemljene elektrode, spektroskopska snimanja su urađena i kada je rastojanje između elektroda bilo podešeno na 4 cm. Na slici 3.2.32 je prikazana evolucija linije na 337,1 nm na tom rastojanju i pritisku od 100 mTorr ali za tri različite snage pražnjenja bez uzorka u komori. Iako je intenzitet zračenja izražen u arbitrarnim jedinicama, intenziteti mereni na različitim snagama su mereni sa istim parametrima ekspozicije pa ih je moguće porediti. Intenziteti linije rastu sa porastom nominalne snage što je očekivano. Takođe, primetan je porast u odnosu na emisiju koja snimljena na rastojanju od 7 cm (slika 3.2.28). Ovaj porast je očekivan iz dva razloga. Podsetimo se da su RMS vrednosti napona, koje su predstavljene na slici 3.2.24, gotovo identične za rastojanje između elektroda od 4 cm i 7 cm. S obzirom da je rastojanje značajno manje a da je pad napona skoro isti, sa aspekta srednjih vrednosti to znači da je tokom pražnjenja sa manjim rastojanjem između elektroda u plazmi postojalo mnogo jače električno polje. Dodatno, efektivno je smanjena zapremina reaktora pa je i gustina energije samim tim porasla. Na snagama od 50 i 100 W intenzitet emisije ostaje praktično konstantan tokom celog intervala snimanja od 300 s. Međutim, iako je snimanje na snazi pražnjenja od 200 W trajalo znatno kraće, evidentan je porast intenziteta emisije. Za 120 s, između prvog i poslednjeg snimka kinetičke serije, ovaj porast iznosi oko 6,5 % i do njega najverovatnije dolazi zbog grejanja radnog gasa.

Evolucija emisije na liniji 337,1 nm je tokom tretmana pamučnog uzorka na pritisku od 100 mTorr i sa rastojanjem između elektroda od 4 cm snimljena na snagama od 50, 100 i 200 W sa i bez uzorka u komori. Rezultat je prikazan na slici 3.2.30. Svi intenziteti linija na graficima, dati u proizvoljnim jedinicama, dobijeni su sa istim parametrima snimanja tako da je omogućeno poređenje. U slučaju kada u komori nema tekstilnog uzorka dobija se približno konstantan intenzitet emisije linije tokom celog posmatranog perioda. Sa druge strane, kada je uzorak u komori kao i slučaju sa većim međuelektrodnim rastojanjem postoji inicijalni skok intenziteta koji je zatim praćen padom intenziteta emisije. Ova promena je, takođe, manje značajna na manjim snagama. Na 50 W ona je nešto viša od 3 %, za snagu od 100 W iznosi 10 % dok je za pražnjenje na 200 W razlika između najintenzivnije i najslabije emisije skoro 16 %. Dakle, u slučaju kada je u komori tekstilni uzorak beljenog pamuka za sve primenjene snage je karakterističan skok intenziteta koji nastaje u prvim trenucima pražnjenja, odnosno koji je primetan kao porast intenziteta linije tokom prvih nekoliko

Plan-paralelno kapacitivno spregnuto pražnjenje

snimaka kinetičke serije. Razlozi za ovo mogu biti višestruki. Ovo može da se događa zbog nesavršenosti izvora snage i nestabilnosti u prvim trenucima nakon uključivanja pražnjenja. Podsetimo se da se od izvora napajanja zahteva da u deliću sekunde počne da isporučuje traženu snagu. Drugi razlog za ovaj skok intenziteta može da bude neusklađenost trenutaka u kome je počelo snimanje i trenutka u kome je pražnjenje uključeno. Praktično, to bi značilo da tokom prvog snimka kinetičke serije čip kamere nije prikupljao svetlost jednako dugo kao tokom pravljenja preostalih snimaka. Ipak, sve greške koje bi na ovaj način mogle da se unesu u merenje, zbog neusklađenosti početnog trenutka snimanja i zbog nesavršenosti sistema napajanja, nastaju tokom vremenskog intervala kraćeg od 1 s i koji traje znatno kraće od perioda koji je potreban da se snimi jedan spektar kinetičke serije. Drugim rečima, promena intenziteta linije, koji traje i po više desetina sekundi, a koji se pojavljuje isključivo kada se u komori nalazi uzorak govori o postojanju procesa koji je posledica interakcije plazme i površine uzorka. Taj proces, očigledno, nije trenutni jer je potrebno da prođe izvesno vreme kako bi emisija postigla svoj maksimum. Brzina dostizanja maksimalnog intenziteta emisije ali i brzina njegovog opadanja nakon tog trenutka zavise od primenjene snage.

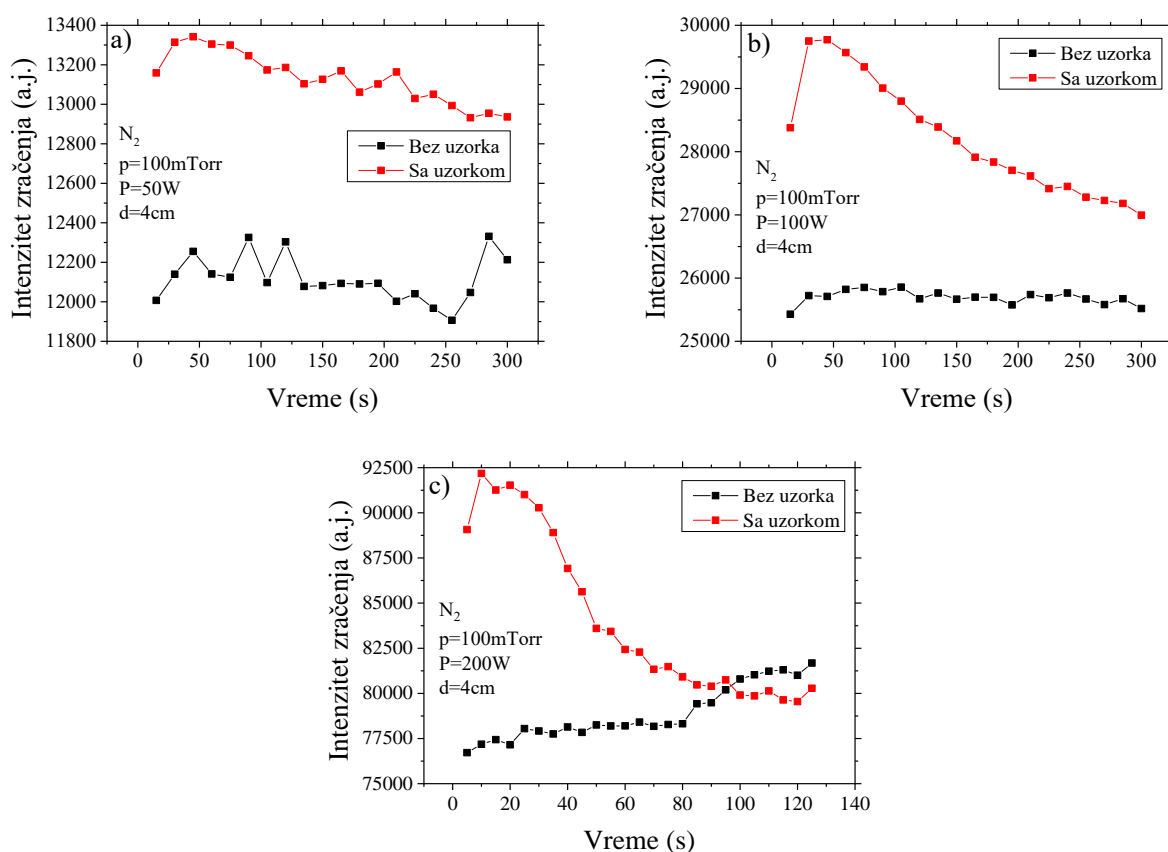

Slika 3.2.30 Poređenje evolucije linije na 337,1 nm tokom pražnjenja sa i bez uzorka u komori. Pritisak 100 mTorr, rastojanje između elektroda 4 cm i snaga: a) 50 W, b) 100 W i c) 200 W.

Na slici 3.2.30 za snage od 50 i 100 W se odnos signala ponaša slično kao i kad međuelektrodno rastojanje iznosi 7 cm, odnosno razlike između signala su veće na većoj primenjenoj snazi. Sa primenjenom snagom od 50 W je 45 sekundi od početka snimanja intenzitet linije bio 9,5 % veći kada je u komori bio uzorak. Posle petog minuta je ovaj odnos opao na oko 5 %. Za snagu od 100 W se odnos intenziteta koji su izmereni sa i bez uzorka kreće od maksimalnih 16 %, na početku snimanja, do minimalnih 6 % nakon 300 s. Situacija se međutim značajno menja kad se primeni snaga od 200 W. U ranim fazama snimanja je emisija tokom tretmana bila nešto preko 19 % veća od emisije

koja je izmerena kada u komori nije bilo uzorka. Međutim, s obzirom na to da emisija tokom tretmana uzoraka opada a da u praznoj komori raste će nakon, okvirno, 90 s intenziteti ovih emisija da se poklope. Na kraju perioda od 120 s će emisija iz komore tokom pražnjenja bez uzorka biti oko 2 % intenzivnija nego tokom tretmana. Jedan od razloga može da bude promena u intenzitetu grejanja radnog gasa usled prisustva uzorka. To toga može da dođe iz više razloga. S obzirom da je uzorak od dielektričnog materijala, mogu da nastanu određene promene u strujno naponskim karakteristikama ali i u efikasnosti predaje snage plazmi. Do spuštavanja temperature gasa može da dođe i zbog isparavanja vode sa površine uzorka ali i zbog toga što uzorak predstavlja barijeru između radnog gasa i uzemljene elektrode koja se takođe zagreva.

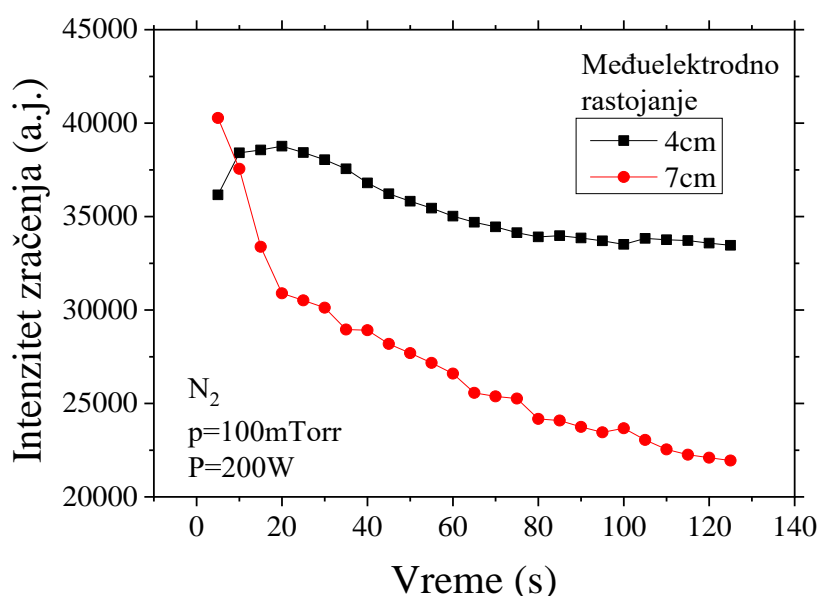

Slika 3.2.31 Poređenje evolucije emisije na 337,1 nm u N_2 pražnjenju na pritisku od 100 mTorr i snazi od 200 W tokom tretmana pamučnog uzorka za međuelektrodno rastojanje od 4 cm (crni simboli) i 7 cm crveni simboli.

Na slici 3.2.31 je prikazano poređenje emisije za iste uslove pražnjenja, $p=100$ mTorr i $P_{RF}=200$ W, ali za različita međuelektrodna rastojanja. Kako bi rezultate bilo lakše uporediti, ova snimanja su napravljena u istom danu, pa se apsolutne vrednosti razlikuju od do sada predstavljenih rezultata. Tokom ovih merenja je u komori bio postavljen uzorak. Osim za prvi snimak kinetičke serije, intenzitet linije na 337,1 nm je tokom celog perioda snimanja bio veći za rastojanje između elektroda od 4 cm. Pored toga što je za manje rastojanje između elektroda veće električno polje, kada su isti primenjeni naponi, veća je i gustina snage po jedinici zapremine, takođe je i svetla regija oko napajane elektrode na manjoj udaljenosti od uzorka, ali i od prostora iz kog se prikuplja svetlost, pa smanjenjem pozadinskog zračenja do izražaja više dolaze procesi vezani za interakciju plazme sa uzorkom. Kao kombinovani rezultat ovih faktora, intenzitet praćene linije će biti veći za međuelektrodno rastojanje od 4 cm. Međutim, pored razlike u intenzitetu, linije ni ne evoluiraju na isti način. Za rastojanje od 7 cm postoji intenzivan pad u prvih dvadeset sekundi koji je nakon toga nešto blaži ali je približno linearan. Sa druge strane je tokom snimanja sa rastojanjem od 4 cm ukupni pad znatno manji. Takođe, primetno je da posle određenog vremena intenzitet linije ostaje praktično konstantan odnosno da postoji izvestan plato. Ovo može da se događa zbog prestanka određenog procesa u aktivnom delu plazme ili zato što interakcija plazme sa uzorkom nakon određenog vremena uđe u ravnotežu. Kako bi se proverilo da li je sličan efekat vidljiv i na manjim snagama ali nakon dužeg vremena, urađena su dodatna snimanja tokom kojih je evolucija praćena znatno duže.

Plan-paralelno kapacitivno spregnuto pražnjenje

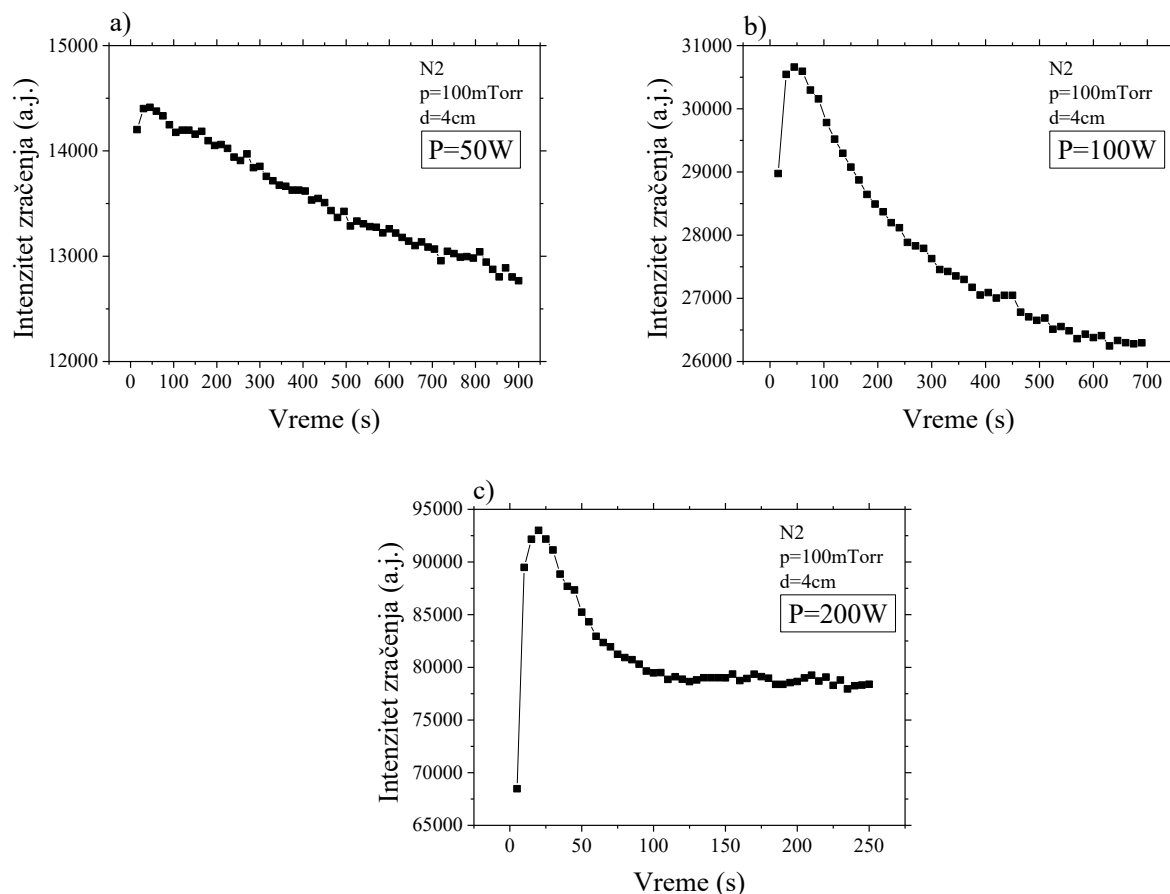

Slika 3.2.32 Evolucije emisije na 337,1 nm u azotnom pražnjenju tokom produženih tretmana pamučnih uzoraka na pritisku od 100 mTorr sa međuelektrodnim rastojanjem od 4 cm na snazi pražnjenja od a) 50 W, b) 100 W i c) 200 W.

Na slici 3.2.30 za snagu od 200 W primećeno je da evolucija intenziteta linije počinje da ulazi u saturaciju. Da bi se ispitala ova pojava, snimanje evolucije intenziteta linije urađeno je sa produženim vremenom tretmana. Produženo praćenje evolucije intenziteta linije tokom tretmana pamučnog uzorka na snazi od 50 W je trajalo 900 s. Prikazano je na slici 3.2.32 a) i može da se primeti praktično uniforman pad tokom celog perioda. Sa povećanjem snage tretmana je bilo potrebno smanjiti i vreme kako ne bi došlo do oštećenja opreme i uzoraka. Za snagu pražnjenja od 100 W, produženi tretman je trajao 700 s. Opadanje intenziteta emisije tokom tretmana, prikazano na slici 3.2.32 b), je u prvom delu perioda nešto izraženije posle čega dolazi do usporavanja. Tokom poslednja dva minuta pražnjenja je intenzitet zračenja bio praktično konstantan. Za najveću primenjenu snagu je produžena evolucija praćena 250 s i prikazana je na slici 3.2.32 c). Treba primetiti da je postizanje maksimalne emisije ostvareno tek nakon četvrtog snimka kinetičke serije. Posle toga sledi oštar pad, ali se već posle 100.-te sekunde intenzitet emisije ne menja sve do kraja snimanja. Očigledno je da ukoliko postoji ravnotežno stanje interakcije plazme i uzorka ili neki proces koji se vremenom gasi, da će do toga ranije da dođe ukoliko se tretman obavlja na većoj snazi.

Plan-paralelno kapacitivno spregnuto pražnjenje

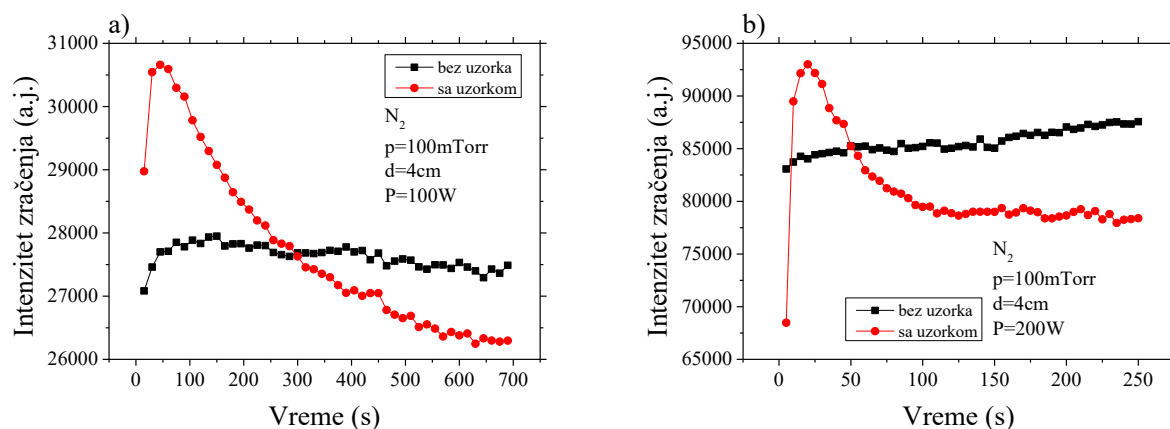

Slika 3.2.33 Poređenje evolucije emisije na 337,1 nm tokom produženog vremena pražnjenja sa i bez uzorka u komori za primenjenu snagu pražnjenja od a) 100 W i b) 200 W.

Emisija tokom dugačkih vremena pražnjenja je praćena, takođe, i kada u komori nije bilo pamučnih uzoraka a poređenje tako dobijenih intenziteta linije na 337,1 nm sa onima koji su izmereni tokom dugačkih tretmana se nalazi na slici 3.2.33. Kao što je već primećeno tokom kraćih snimanja, emisija će tokom pražnjenja bez uzorka u komori na primenjenoj snazi od 100W tokom celog perioda snimanja ostati praktično konstanta. Tokom produženog praćenja evolucije, prikazano na slici 3.2.33 a), može da se primeti postepeno opadanje intenziteta sa protokom vremena. Suprotno tome, kada se snaga pražnjenja podesi na 200 W, intenzitet emisije će tokom vremena, najverovatnije zbog zagrevanja gasa u plazmi, da raste. Ono što se tokom kraćeg praćenja nije primetilo je da i na snazi od 100 W dolazi do izjednačavanja intenziteta emisije tokom pražnjenja sa i bez uzorka u komori. Nakon okvirno 300 s emisija linije na 337,1 nm postaje intenzivnija ukoliko se u komori ne nalazi uzorak. Za veću snagu pražnjenja zračenje iz plazme u kojoj nema uzorka postaje intenzivnije već nakon 50 s.

Može da se primeti da postoje određene razlike u vrednosti apsolutnih intenziteta linije za merenja u kojima je njena evolucija praćena tokom kraćeg i dužeg perioda. Dodatnim merenjima je ustanovljeno da male promene u poziciji opreme mogu da utiču na apsolutne vrednosti snimljene emisije ali da će linija i dalje da evoluiru na identičan način. Tokom naših merenja su, kako bi efekat ove greške sveli na minimum, snimanja evolucija linije sa i bez uzorka rađena istog dana. Na taj način možemo da kažemo da do promene u intenzitetu ne dolazi zbog toga što je merna oprema nešto drugačije postavljena nego da ta promena nastaje kao posledica suštinski drugačijeg pražnjenja. Uzrok ovih razlika će biti predmet daljih istraživanja ali jedan od razloga može da bude i nešto drugačija prielektrodna oblast na uzemljenoj elektrodi koja neće da bude identična ukoliko je ona prekrivena tekstilom koji je dielektrik.

Plan-paralelno kapacitivno spregnuto pražnjenje

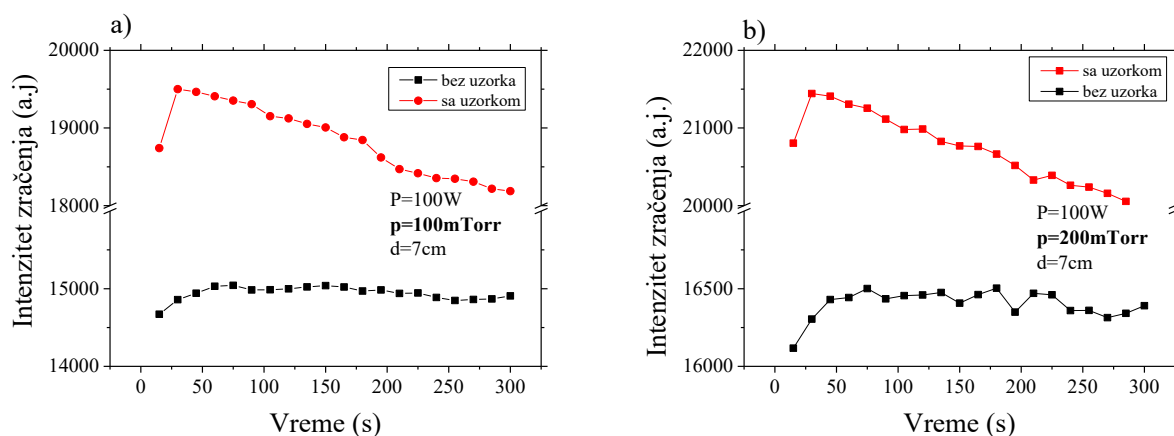

Slika 3.2.34 Evolucija linije na 337,1 nm snimljena u azotnom pražnjenju sa (crvena boja) i bez pamučnog uzorka (crna boja) sa primenjenom snagom od 100 W i na međuelektrodnom rastojanju od 7 cm na pritisku od a) 100 mTorr i b) 200 mTorr.

Dodatno ispitivanje je napravljeno poređenjem evolucije linije snimljene u pražnjenju sa i bez uzorka ali na dva različita pritiska, 100 i 200 mTorr. Za ovo poređenje, prikazano na slikama 3.2.34 a) i b), je rastojanje između napajane i uzemljene elektrode bilo podešeno na 7 cm a primenjena je snaga od 100 W. Intenziteti linije koji su dobijeni merenjem na većem pritisku su nešto veći i tokom tretmana pamučnog uzorka i kada njega nije bilo u komori u poređenju sa onima koji su dobijeni na pritisku od 100 mTorr. Međutim, na 200 mTorr, je odnos intenziteta linije koja je dobijen u pražnjenjima sa i bez uzorka veći od onog koji je dobijen merenjima na nižem pritisku.

Pored linija azotovog molekula, zanimalo nas je da li je moguće pratiti evoluciju i nekih drugih molekulskih linija. Na slici 3.2.35 se nalazi deo spektra u bliskoj UV oblasti u kome se očekuju linije iz $\text{NO}\gamma$ trake ovog molekula. Ovaj spektar je snimljen jednom tokom pražnjenja kada u komori nije bilo uzorka i dva puta tokom tretmana pamučnog uzorka. Jednom ja snimanje počelo sa početkom tretmana a drugi put je počelo dva i po minuta posle uključivanja pražnjenja. U sva tri slučaja je dobijen vrlo sličan spektar, što znači da se $\text{NO}\gamma$ linije emituju i bez uzorka u komori. Ukupne razlike u apsolutnim intenzitetima, u arbitrarnim jedinicama, su bile oko 10 %.

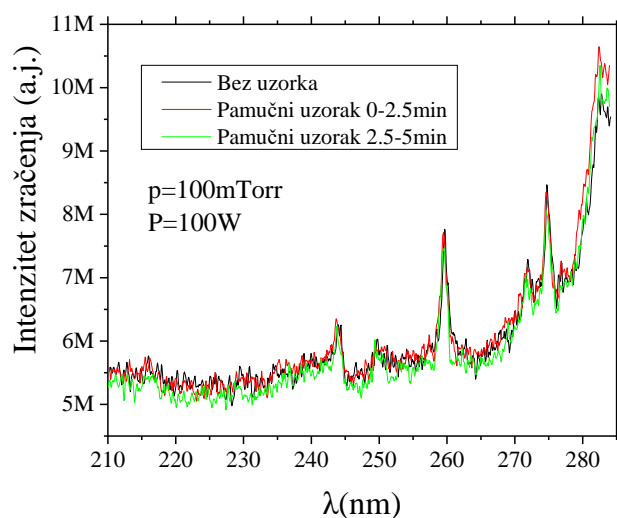

Slika 3.2.35 Deo emisionog spektra plazme snimljen tokom pražnjenja bez uzorka (crna linija) i tokom tretmana uzorka, od samog početka (crvena linija) i dva i po minuta posle početka pražnjenja (crna linija), na pritisku od 100 mTorr i snazi pražnjenja od 100 W.

Evolucija linija NO trake (NO γ)

NO γ linije koje mogu da se vide u spektru prikazanom na slici 3.2.39 pripadaju prelazu $A^2\Sigma^+ \rightarrow X^2\Pi$ a najintenzivnije linije se nalaze na 259,6 nm (prelaz 0-3) i 272,2 nm (prelaz 0-4). Kao što može da se primeti na istoj slici, intenzitet emisije na tim talasnim dužinama je prilično slab. Kako bi njihova evolucija tokom vremena uopšte mogla da se prati, način snimanja i obrade podataka je morao da bude nešto drugačiji nego tokom praćenja N₂ molekularskih linija. Pre svega je bilo potrebno povećati broj akumulacija tokom pravljenja jednog snimka kinetičke serije zbog čega je i vreme akumuliranja povećano sa 15 na 30 s. Time je broj spektara snimljen tokom ukupnog trajanja tretmana tj. u kinetičkoj seriji praktično prepolovljen. Međutim, čak i posle ove promene je emisija na ispitivanim talasnim dužinama ostala takva da nije uvek bilo moguće da se sa sigurnošću odredi intenzitet vrha emisione linije. Zbog toga smo odlučili da se umesto intenziteta linije kao parametar koristi ukupna površina ispod linije. Ona se numerički dobija kao integral intenziteta po talasnim dužinama pri čemu se vodi računa da je pozicija osnovne linije u odnosu na koju se računa površina uvek isto postavljena.

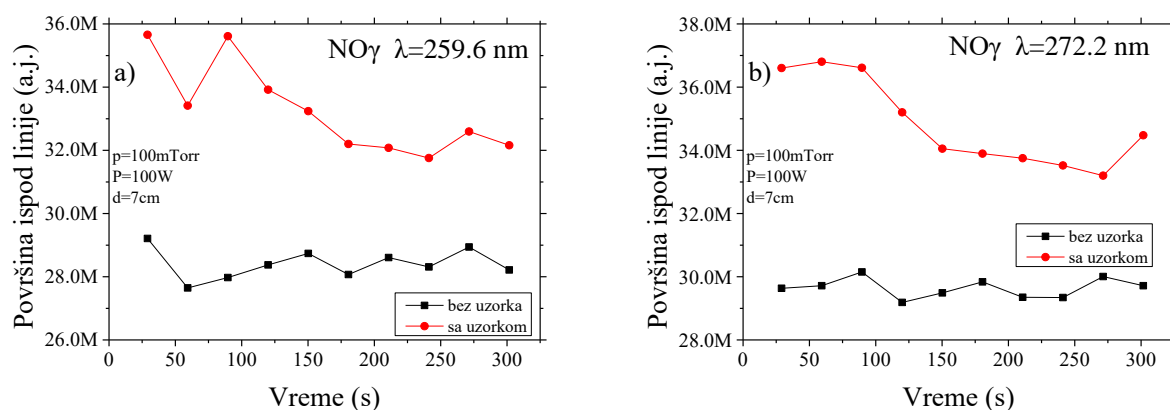

Slika 3.2.36 Evolucija NO γ linija na a) 259,6 nm i b) 272,2 nm snimljene tokom azotnog pražnjenja sa (crvena linija) i bez pamučnog uzorka (crna linija) na pritisku od 100 mTorr, snazi od 100 W i rastojanjem između elektroda od 7 cm.

Primer evolucije emisije dve linije iz NO γ trake je dat na slici 3.2.36. Snimanja su rađena na pritisku od 100 mTorr i snazi od 100 W sa rastojanjem između napajane i uzemljene elektrode od 7 cm. Obe linije evoluiraju na vrlo sličan način. Pad ukupnog intenziteta emisije tokom tretmana pamučnog uzorka je nešto intenzivniji na liniji koja se nalazi na 259,6 nm, slika 3.2.36 a), u odnosu na onu koja se nalazi na 272,2 nm, slika 3.2.36 b). Emisija u komori bez uzorka je praktično konstantna na obe talasne dužine. Ovaj način promene intenziteta linija iz NO γ trake tokom vremena je vrlo sličan onome koji zabeležen za linije molekularskog azota. Zbog veoma slabog intenziteta emisije, detaljna analiza evolucije linija iz NO γ traka će tek biti urađena.

Evolucija jonske linije molekula azota (391,4 nm)

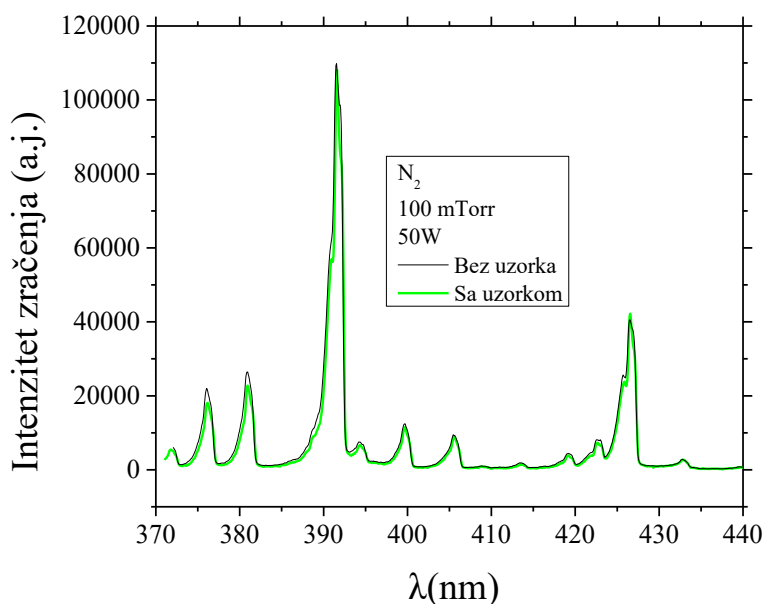

Slika 3.2.37 Intenzitet zračenja iz pražnjenja (100 mTorr, 50 W, N_2) sa i bez pamučnog uzorka u komori, uveličan na oblast između 370 i 440 nm.

Na slici 3.2.37 nalazi jedan deo spektra, između 370 nm i 440 nm koji je snimljen u N_2 pražnjenju snage 50 W na pritisku od 100 mTorr. Crnom linijom su obeleženi podaci dobijeni snimkom plazme bez uzorka dok je zelenom bojom označen spektar iz pražnjenja sa pamučnim uzorkom. U prikazanom delu spektra dominiraju najintenzivniji prelazi Prve negativne trake N_2^+ . U ovom delu spektra su, pored prikazanih linija u skladu sa rezultatima iz literature [191]–[193] mogle da se očekuju i sledeće linije koje na našim snimcima nisu vidljive: CH traka (oko 390 nm i 431 nm), CO traka (412 nm) i $H\gamma$ (434,1 nm). Činjenica da ove linije nisu vidljive može da se objasni time da uslovi pražnjenja nisu bili dovoljno intenzivni da se ove funkcionalne grupe, bombardovanjem aktivnim česticama, odvoje od pamučnog uzorka i da se, u dovoljnoj količini, nađu u plazmi.

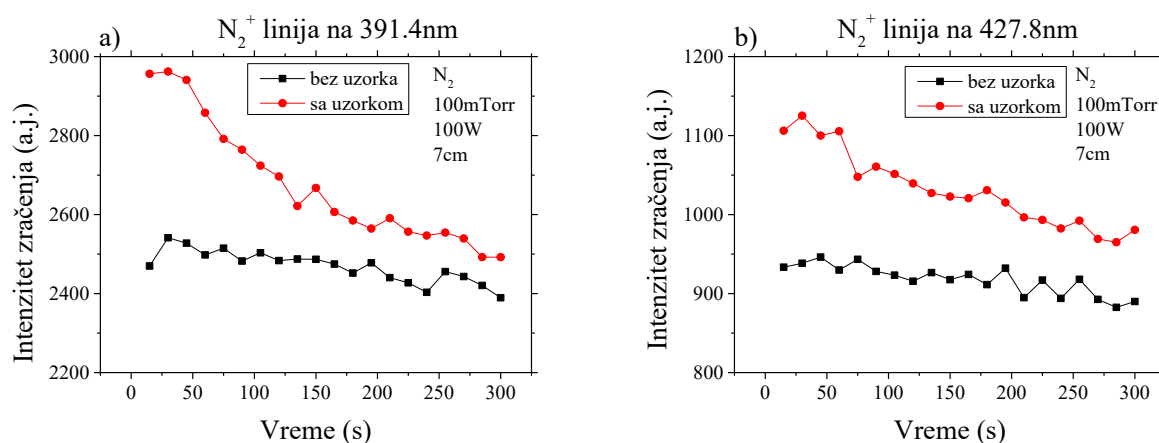

Slika 3.2.38 Evolucija linije N_2^+ jona na a) 391,4 nm i b) 427,8 nm u azotnom pražnjenju sa i bez pamučnog uzorka u komori na pritisku od 100 mTorr, snazi od 100 W i međuelektrodnom rastojanju od 7cm.

Iako im je intenzitet nešto slabiji, bili smo u mogućnosti da ispratimo vremensku evoluciju linija N_2^+ jona. Na slici 3.2.38 a) se nalazi evolucija linije na 391,4 nm a na slici 3.2.38 b) linije na 427,8 nm. Iako njihove promene tokom vremena liče na promene molekulskih linija, određene razlike ipak postoje. Intenzitet linija tokom pražnjenja bez uzorka u komori nije konstantan. Iako je totalni intenzitet slab a promena spora, razlika između minimalne i maksimalne vrednosti tokom pražnjenja u komori u kojoj se ne nalazi uzorak iznosi oko 6 do 7 % za obe praćene linije. Ova razlika je još izraženija tokom tretmana pamučnog uzorka. Razlika između minimalne i maksimalne vrednosti intenziteta emisije na talasnoj dužini od 427,8 nm iznosi 16,6 % dok na talasnoj dužini od 391,4 nm ona iznosi čak 18,9 %. Ovo takođe govori u prilog tome da postavljanjem uzorka, u kome postoji određena količina vode, u pražnjenju nastaje plazma hemija koja pogoduje pobuđivanju molekula azota. Posledično će lakše dolaziti i do jonizacije zbog čega je u prvih nekoliko snimaka kinetičke serija emisija jonskih linija velika. Vremenom, kako je sve manje čestica koje napuštaju zapreminu uzorka, smanjuje se količina interakcija između azota i čestica iz uzorka što dovodi do smanjenja broja pobuđenih molekula azota. Kao posledicu imamo i manje jonizacija pa će biti smanjena i emisija na talasnim dužinama koje odgovaraju N_2^+ jonima.

Da bi se dodatno ispitalo kako postavljanje uzorka utiče na emisiju iz plazme, urađena su spektroskopska snimanja sa još dve vrste uzoraka, PET tkaninom i staklom. Osobine ovih uzoraka poput morfologije površine, poroznosti, strukture, hidrofilnosti, mogućnosti adsorpcije, hemijskog sastava itd. su različite za ove tri vrste uzoraka. Hemijske strukture ispitivanih uzoraka su prikazane na slici 3.2.39. Vlakna pamuka su sačinjena skoro u potpunosti od celuloze na čijim se spoljnim vezama nalaze OH grupe. Celuloza, čija je formula $C_6H_{10}O_5$, je polisaharid koji sačinjen od linearnih lanaca koji sadrže stotine ili hiljade jedinica D-glukoze. Sa spoljne strane ovog lanca se nalaze dvostrukom vezom spojeni kiseonikovi atomi dok OH grupa nema. PET (PoliEtilen-Tereftalat) tkanina je sačinjena od lanca u kome se ponavlja struktura čije je formula $C_{10}H_8O_4$. Staklo spada u grupu amorfnih čvrstih materijala. Osnovna jedinica građe ovog materijala je silikon dioksid, SiO_2 , ali se u njemu nalaze i različiti aditivi poput natrijum oksida, Na_2O , natrijum karbonata, Na_2CO_3 , kalcijum oksida, CaO , magnezijum oksida, MgO , aluminijum oksida, Al_2O_3 , borovog oksida, B_2O_3 , i drugih. Tokom tretmana tri različita tipa uzoraka smo vodili računa o tome da njihove površine budu jednake.

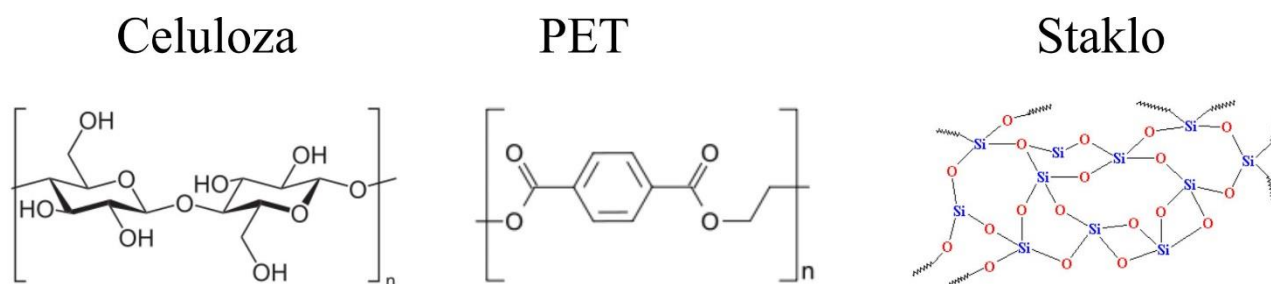

Slika 3.2.39 Hemijska struktura pamuka (celuloza), PET tkanine i stakla

Praćenjem linija azotovih molekula je primećeno da postoji velika razlika kako u njihovim intenzitetima tako i načinu promene tokom vremena zavisno od toga da li se u azotnom pražnjenju nalazio uzorak ili ne. Uopšteno govoreći, izlaganjem bilo kog materijala plazmi se očekuje da će, pod određenim uslovima, bombardovanjem jonima i elektronima biti moguće da se iz njihove površine odvoje određeni strukturni elementi. Prisustvo čestica koje su izbijene sa površine tretiranog uzorka bi, ukoliko ih ima u dovoljnoj koncentraciji i ako nakon pobuđivanja emituju u opsegu talasnih dužina koje su posmatrane, trebalo da bude „vidljivo“ u emisionom spektru. Spektri koji su dobijeni tokom tretmana tri različite vrste uzorka su prikazani na slici 3.2.40. Iz prikazanih struktura pamuka, PET

tkanine i stakla je jasno da je za ove vrste uzoraka najmanje energije potrebno da se iz celuloznog lanca odvoje OH grupe, što je i vidljivo na spektru pamučnog uzorka prikazanom na slici 3.2.40.

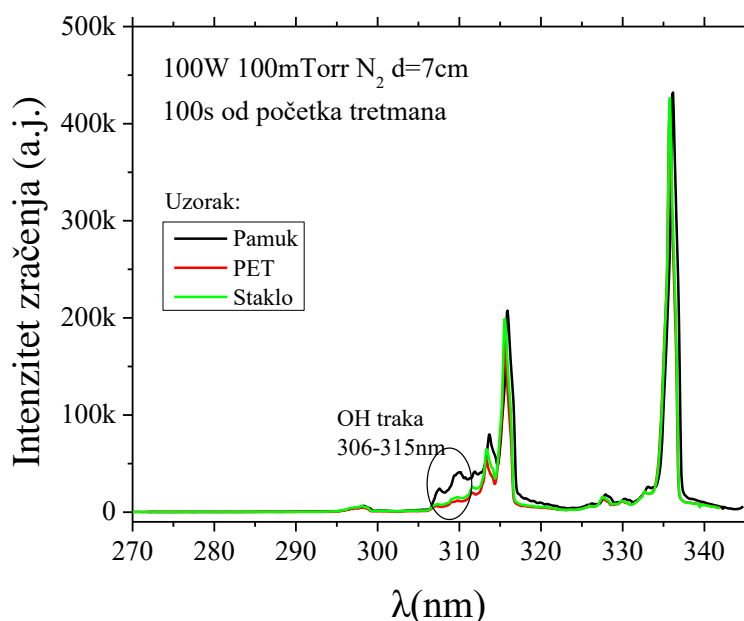

Slika 3.2.40 Poređenje spektara tokom tretmana tri različita uzorka na pritisku od 100 mTorr, snazi od 100 W, međuelektrodnim rastojanjem od 7 cm koji su snimljeni 100 s od početka tretmana. Pamučni uzorka je obeležen crnom linijom, PET crvenom a stakleni zelenom.

Evolucija linije azotovog molekula na 337,1 nm tokom pražnjenja u komori u kojoj nema uzoraka i tokom tretmana PET tkanine i staklenog uzorka je prikazana na slici 3.2.40. Još jedan dokaz da osobine plazme, uključujući i optičku emisiju, zavise od vrste uzorka koji se tretira se vidi iz činjenice da je emisija tokom tretmana PET tkanine i stakla slabija nego kad u komori nema uzoraka. Podsetimo, ovo je potpuno suprotno ponašanje od onog koje je primećeno tokom tretmana pamučnih uzoraka. Sa druge strane, tokom tretmana ove dve vrste uzoraka je, takođe, primećen pad intenziteta emisije koji je postoji i tokom tretiranja pamuka. Ovaj pad emisije iznosi oko 10 % za oba uzorka.

Tretmani tekstilnih uzoraka plazmom su pokazali da se pražnjenjima u azotu postižu manje fizičke promene na površini uzorka nego, recimo, pražnjenjima u kiseoniku ili vazduhu. Odnosno promene osobina poput hidrofilnosti ili morfologije uzorka su ili neprimetne ili značajno manje [194], [195] nego nakon tretmana u drugim gasovima. S obzirom da je u pitanju relativno blaga plazma, vidljive promene u spektru nastale su samo tokom tretmana pamučnog uzorka i to pojavom OH trake. Tokom tretmana stakla i PET tkanine uslovi pražnjenja nisu bili dovoljni da se, u meri u kojoj bi prisustvo radikala moglo da se otkrije optičkom emisijom spektroskopijom, u plazmi nađe dovoljna količina čestica koje potiču sa površine uzorka. Sa druge strane, tretmanom u azotu se postiže značajnija promena hemijske strukture površine koja se vidi kroz pojačano prisustvo funkcionalnih grupa ali i postojanije nanošenje materijala na površinu uzorka [94], [182], [196].

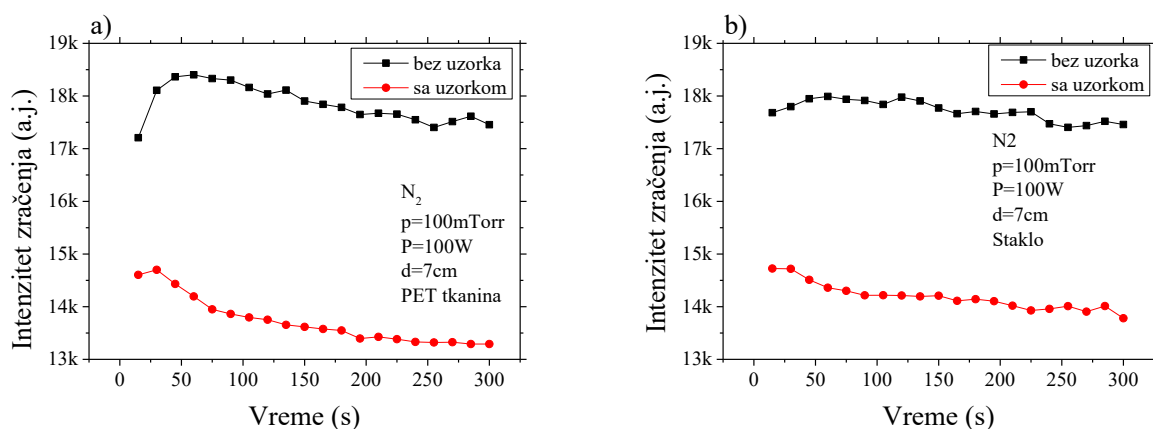

Slika 3.2.40 Evolucija azotove linije na 337,1 nm tokom pražnjenja bez uzorka i tokom tretmana a) PET tkanine i b) stakla na pritisku od 100 mTorr, snazi od 100 W i sa međuelektrodnim rastojanjem od 7 cm.

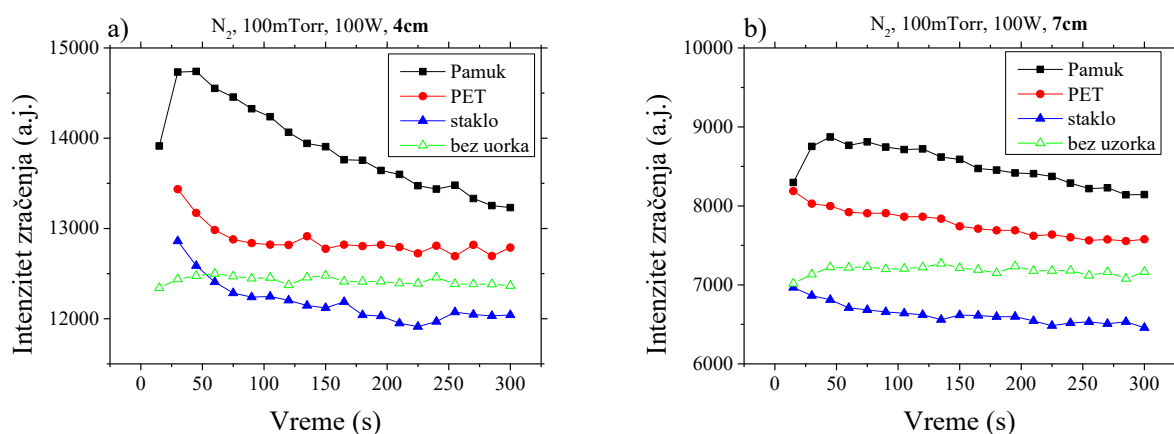

Slika 3.2.41 Evolucija azotove linije na 315,9 nm tokom tretmana pamuka (crna linija), PET tkanine (crvena linija) i stakla (plava linija) na snazi od 100 W i pritisku od 100 mTorr sa rastojanjem između elektroda od a) 4 cm i b) 7 cm.

Poređenje evolucije azotove linije na 315,9 nm tokom tretmana sva tri različita uzorka za dva različita rastojanja između napajane i uzemljene elektrode je prikazano na slici 3.2.41. Ova linija tokom tretmana evoluirala na identičan način kao i linija na 337,1 nm ali su razlike u intenzitetu emisije između različitih uzoraka manje. Najintenzivnija emisija linije 315,9 nm je snimljena tokom tretmana pamučnog uzorka, slabiji intenzitet je izmeren tokom tretmana PET tkanine a najslabiji tokom tretmana stakla.

Ponašanje obe praćene linije (337,1 nm i 315,9 nm) donekle se može objasniti strukturom samih uzoraka. Naime od sva tri materijala koja su korišćena najhidrofilniji je pamuk. To znači da, ukoliko nije čuvan u specijalnim uslovima, u njegovoj zapremini postoji određena količina vode koja će da počne da napušta uzorak kada se on nađe na dovoljno niskom pritisku. Pored toga i hemijska struktura pamuka je takva da je iz njega najlakše izdvojiti funkcionalne grupe, poput OH radikala. Zbog toga može da se očekuje da će tretmanom ovakvog materijala u samoj plazmi da se nađu vrste koje mogu da interaguju sa česticama radnog gasa. Osim što u određenoj meri one mogu da utiču i na ukupnu koncentraciju čestica u komori, pogotovo u prvim trenucima tretmana, njihovo prisustvo može značajno da utiče i na raspodelu ostalih čestica po energijama. Imajući još u vidu da prisustvo uzorka utiče i na protok toplotne energije od napajane ka uzemljenoj elektrodi ali i na način formiranja

prielektrodne oblasti, jasno je da se postavljanjem uzoraka od različitih materijala utiče i na broj emitera (pobuđenih N_2 molekula u našem slučaju) koji ne može da bude isti čak i kad su isti uslovi pražnjenja (poput pritiska, snage i međuelektrodnog rastojanja). S obzirom da ni jedan od odabranih materijala u sebi ne sadrži azot, do promene u intenzitetu emisije linije može da dođe samo zbog promene plazma hemije. Očigledno je da se unošenjem pamučnog uzorka ona menja na taj način da olakšava pobuđivanje N_2 molekula. PET tkanina je značajno hidrofobnija i ima uniformniju strukturu pa je manja šansa da će se u zapremini uzorka od ovog materijala naći čestice koje mogu da utiču na plazma hemiju. Zbog toga je emisija praćene linije nešto manja nego kada je u komori pamučni uzorak ali je i dalje veća nego kada u komori uzorka nije bilo. Najslabiji intenzitet emisije smo dobili iz stakla koje je, iako amorfne prirode, ipak kristal, takođe hidrofoban, iz kog plazma na primenjenim snagama teško može da izbija čestice sa površine.

Dodatna spektroskopska snimanja su urađena sa ciljem dobijanja prostorno razloženih merenja. S obzirom na to da se svetlost prikuplja iz oblasti koja nije precizno definisana, odnosno da je vidno polje konusnog oblika koji se širi sa udaljavanjem od tačke gde se nalazi optički element, merne pozicije su označene samo kao „nivo uzorka“, „centar“ i „napajana elektroda“. Pozicija u nivou uzorka je korišćena tokom svih ostalih merenja, odnosno snimano je tako da je gornja polovina bočnog prozora bila blokirana kako bi se svetlost prikupljala samo iz prostora oko uzemljene elektrode odnosno uzorka. Tokom merenja na poziciji koja je označena kao „centar“ je korišćen isti prozor ali je bila blokirana njegova donja polovina. Na taj način je omogućeno prikupljanje svetlosti iz prostora između elektroda. Za snimanje emisije iz oblasti koja je najbliža napajanoj elektrodi je korišćen je prozor sa prednje strane komore, na njenim vratima, i to tako što je ostao neblokirano samo njegov najviši deo.

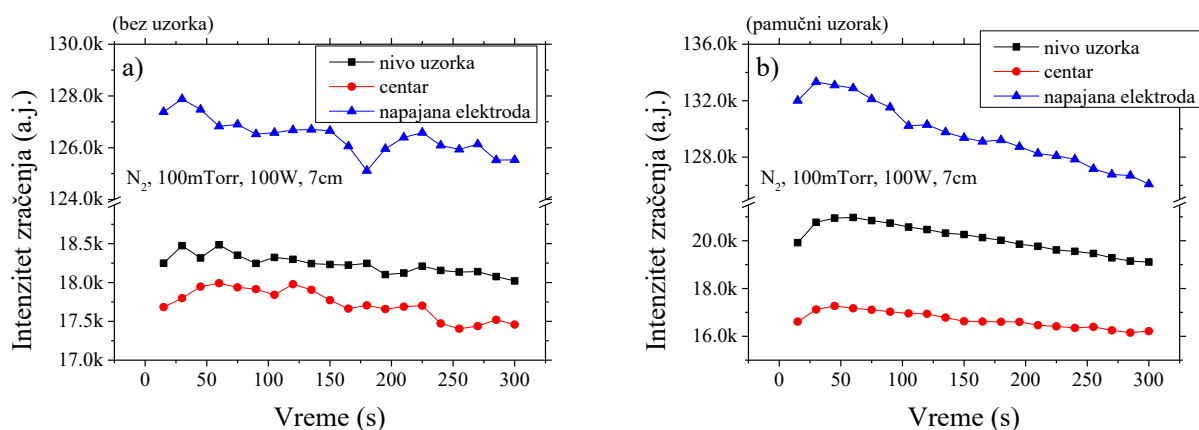

Slika 3.2.42 Poređenje evolucije azotove linije na 337,1 nm snimljene na tri različite pozicije na pritisku od 100 mTorr, snazi od 100 W, međuelektrodnim rastojanjem od 7 cm dok u komori a) nije bilo uzorka i b) dok je tretiran pamučni uzorak

Evolucije N_2 linije na 337,1 nm koje su snimljene, za sve tri pozicije, kada u komori nije bilo uzorka su prikazane na slici 3.2.42 a). Korišćeni su standardni uslovi pražnjenja odnosno pritisak od 100 mTorr, snaga od 100 W i rastojanje između elektroda od 7 cm. Prikazane vrednosti skalirane su tako da omoguće poređenje između različitih pozicija. Može da se primeti da je najslabiji intenzitet linije dobijen snimanjem emisije iz oblasti pražnjenja između elektroda. Ovo je donekle i očekivano jer se i golim okom vidi da je svetljenje oko uzemljene elektrode intenzivnije nego u centralnoj oblasti pražnjenja a da je najintenzivnije u prostoru ispred napajane elektrode. U oblasti oko uzemljene elektrode, gde se formira prielektrodna oblast, će koncentracija neutralnih čestica biti ista kao u

svakoj drugoj tački prostora ali joni i elektroni u toj oblasti imaju veće energije. Zbog toga će do procesa pobuđivanja molekula azota da dolazi nešto lakše, što smo mi i izmerili kao emisiju većeg intenziteta nego iz centralne oblasti plazme. Najveći intenzitet praćene linije je izmeren iz pozicije koju smo označili „napajana elektroda“. Pored toga što takođe dolazi do formiranja prielektrodne oblasti, u tom delu zapremine je najveći pad napona, električno polje, koncentracije i energije aktivnih čestica. Zbog svih ovih faktora je izmerena emisija iz tog dela zapremine je sedam do osam puta veća nego na druge dve pozicije.

Intenzitet emisije linije na 337,1 nm tokom tretmana pamučnog uzorka i njena evolucija tokom vremena su prikazani na slici 3.2.42 b). Najmanji intenzitet je izmeren iz prostora između elektroda, nešto intenzivnija emisija je dobijena iz prostora oko uzemljene elektrode dok je višestruko veći intenzitet linije dobijen iz prostora oko napajane elektrode. Na sve tri pozicije linije evoluiraju na sličan način. Maksimalum intenziteta se postiže na drugom ili trećem snimku kinetičke serije posle čega polako opada do kraja perioda od 300 s. Najmanji ukupni pad intenziteta, od oko 6 %, je zabeležen merenjem na poziciji u blizini napajane elektrode odnosno iz prostora koji je najdalji od uzorka. Nešto veći pad, od 7 %, je izmeren u centralnom delu plazme dok je najveći pad intenziteta linije, u odnosu na maksimalni tokom tretmana uzorka, zabeležen u prostoru neposredno iznad uzorka i iznosi 10 %. Ovo ide u prilog hipotezi da promenu intenziteta emisije uzrokuju čestice koje sa uzorkom ulaze u plazmu. U početku će njihov broj biti veliki pa će i emisija biti velika. Vremenom će se one iscrpeti što će da dovede do slabljenja intenziteta emisije. Tokom pražnjenja bez uzorka u komori je takođe najveća emisija bila u blizini napajane elektrode, zatim značajno manje u nivou uzemljene elektrode dok je najslabija bila u prostoru između njih. Za razliku od pražnjenja tokom tretmana, porast emisije u prvih nekoliko snimaka kinetičke serije je manje izražen. Treba primetiti da tokom pražnjenja, kako sa uzorkom tako i bez njega, intenzitet emisije evoluira na vrlo sličan način, iako su apsolutne vrednosti različite. To može da znači da su u celoj zapremini vidljivi isti procesi ili da je tokom snimanja, zbog ugla „gledanja“, prostor oko uzemljene elektrode bio nedovoljno zaklonjen.

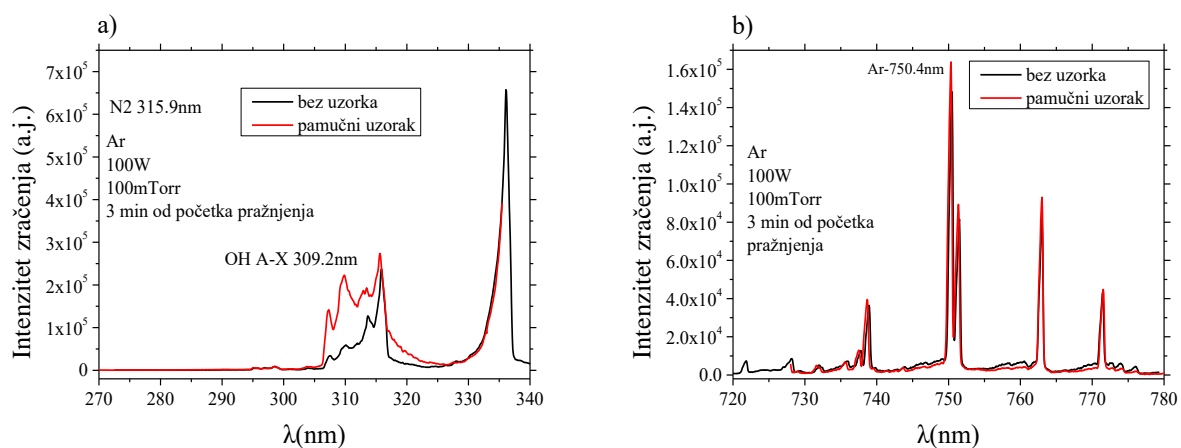

Slika 3.2.43 Spektar zračenja iz a) bliskog UV-a i b) vidljivog dela spektra pražnjenja u argonu koji snimljen 3 min nakon početka pražnjenja na snazi 100 W i pritisku 100 mTorr sa rastojanjem između elektroda od 7 cm.

Kako bi se ispitalo da li interakcija koja proizvodi efekat promene intenziteta azotnih linija pripada fizičkim ili hemijskim procesima indukovanim u plazmi, urađena su merenja emisije iz argonskog pražnjenja iz istog reaktora sa rastojanjem između elektroda od 7 cm. Usled slabe hemijske reaktivnosti i velike molekulske mase argonsko pražnjenja na površini uzorka indukuje fizičke procese interakcije (nagrizanje, raspršivanje) [197], [198]. Na slici 3.2.43 je prikazan spektar

argonske plazme koji dobijen iz komore u kojoj nije bilo uzorka i tokom tretmana pamučnog uzorka. Na slici 3.2.43 a) se nalazi deo spektra između 270 i 340 nm dok je na slici 3.2.43 b) prikazan deo između 720 i 780 nm. Iako je ovom prilikom u komoru upuštan samo argon, u spektru su vidljive i linije azotovog molekula kao posledica prisustva nečistoća tj. vazduha u komori, adsorbovanih N_2 molekula na zidovima komore ili uzorku [199]. Tokom tretmana pamučnih uzoraka se u spektru pojavljuju i linije OH grupe (slika 3.2.43 a)) najverovatnije zbog toga što su delovanjem plazme prekinute veze kojima se ova grupa drži za lanac celuloze. Doprinos OH emisiji usled prisustva vode u pamučnom uzorku je minimalan što se može videti pošto je OH traka gotovo neprimetna u slučaju tretmana uzorka u azotnom pražnjenju (slika 3.2.44). Tokom tretmana je, takođe, bio veći intenzitet i azotovih i argonovih linija.

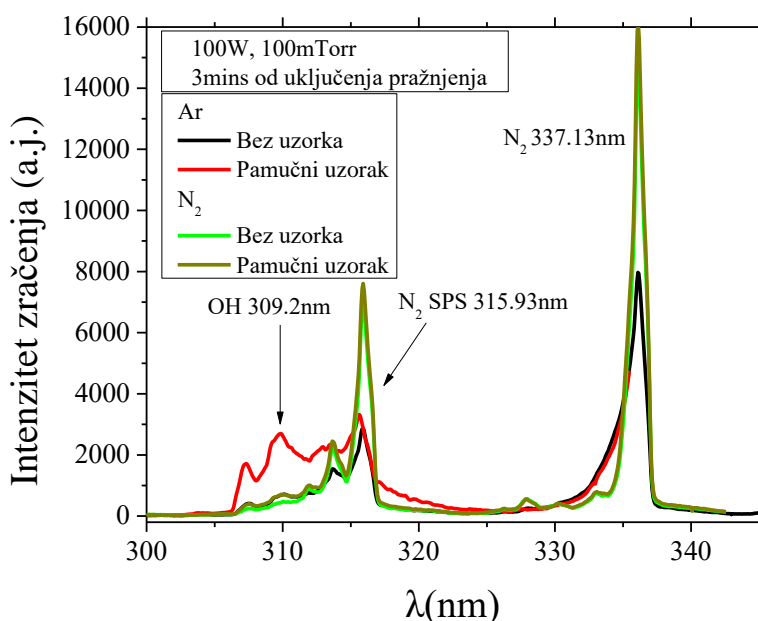

Slika 3.2.44 Poređenje spektara koji su dobijeni u argonskom i azotnom pražnjenju u istim uslovima (100mTorr, 100W 7 cm između uzemljene i napajane elektrode) 3 minuta od uključivanja pražnjenja, sa i bez uzorka u komori. Pre snimanja i upuštanja gasova je pritisak spuštana na 3 mTorr

Poređenje evolucije linija argona i azota tokom tretmana pamučnog uzorka i tokom pražnjenja bez uzorka i sa uzorkom u komori je za dve snage prikazano na slici 3.2.45 i to za snagu od a) 50W i b) 100 W. Praćena je argonova linija na 750 nm i linija iz trake azotovog molekula na 315,9 nm. Kao što je i do sada bio slučaj, tokom pražnjenja bez uzorka u komori je intenzitet linija tokom vremena ostajao približno konstantan. Sa druge strane, intenzitet argonove linije će, tokom tretmana, da evoluiru slično azotovim linijama tokom tretmana pamučnog uzorka u plazmi azota. Maksimum intenziteta se dostiže u prvih 50 s tretmana, posle čega dolazi do pada koji je značajno izraženiji na većoj primenjenoj snazi. Ono što treba primetiti je da se za ovo vreme tretmana i na snazi od samo 100 W već vidi usporavanje pada emisije argonove linije ali i linije azota. Podsetimo da ovo usporeenje nije primetno u plazmi u azotu na pritisku od 100 mTorr i snazi pražnjenja od 100 W.

Plan-paralelno kapacitivno spregnuto pražnjenje

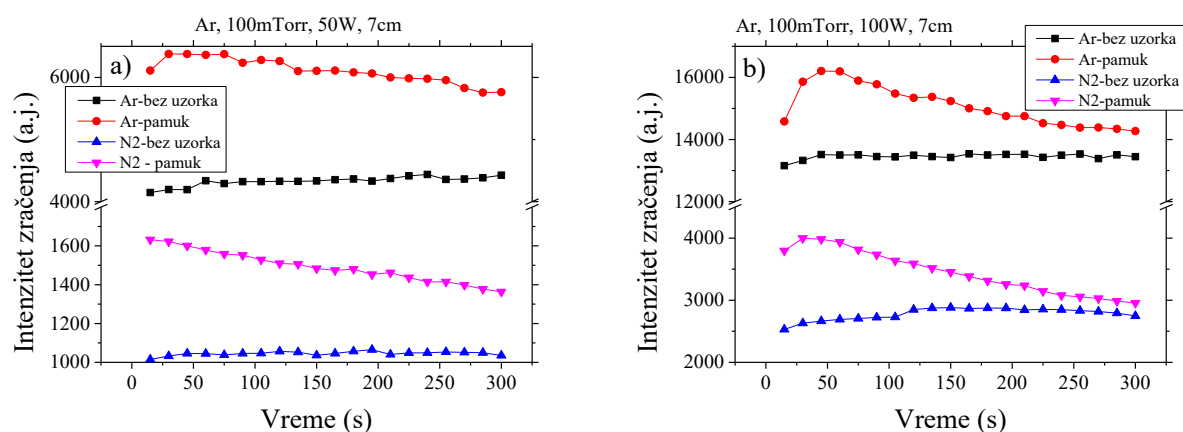

Slika 3.2.45 Evolucije argonove (750 nm) i azotove (315,9 nm) linije tokom pražnjenja u argonu na pritisku od 100 mTorr, međuelektrodnom rastojanju od 7 cm sa primenjenom snagom od a) 50 W i b) 100 W.

Glavni razlog za različitu evoluciju emisija argonske i azotove linije tokom tretmana pamučnih uzoraka u ovim gasovima leži pre svega u tome što oni drugačije interaguju i sa površinom uzorka ali i sa česticama koje iz uzorka ulaze u pražnjenje. Kao što je već rečeno, argon će interagovati nešto intenzivnije, nagrizanjem površine i izbijanjem čestica sa nje. Azot je sa druge strane hemijski reaktivniji i tokom interakcije sa površinom je manje menja u fizičkom smislu. Međutim, sa njom može da reaguje u hemijskom smislu, pogotovo tokom tretmana uzoraka koji su sačinjeni od organskih molekula. Dodatno, i u samom pražnjenju može da dođe do hemijskih reakcija između molekula azota i radikala koji potiču iz uzoraka. Iz navedenog možemo da zaključimo da će sastav uzorka, količina i vrsta primesa u pražnjenju mnogo više da utiče na način pobuđivanja azotnih molekula nego na pobuđivanje hemijski neaktivnog atoma argona. Zbog toga će emisija argona, opadanjem količine primesa u pražnjenju (pre svega vode), brže da dođe u ravnotežno stanje.

Uklanjanje nečistoća iz uzorka i zidova komore

Dodatna ispitivanja su izvršena kako bi se definisao glavni izvor OH radikala u plazmi. S tim ciljem je jedno snimanje spektra obavljeno tek nakon što je uzorak u vakuumu, na najmanjem pritisku koji smo mogli da postignemo, proveo sat vremena. Na taj način bi uzorak na niskom pritisku proveo dovoljno vremena da se iz njegove zapremine ukloni veliki deo isparljivih materija, primarno vode. Time bi dobijeni spektar u najvećoj meri zavisio samo od interakcije plazme sa površinom uzorka dok bi efekat nečistoća koje sa uzorkom ulaze u komoru bio sveden na minimum. Još jedno ispitivanje je rađeno tako što je u komori, pre merenja, uključivana kiseonična plazma kako bi se iz zidova uklonile nečistoće. Na taj način bi se značajno smanjili efekti molekula koji su adsorbovani na zid komore a razlika u intenzitetu emisije bi trebalo da bude najočiglednija snimanjem spektra bez uzorka u komori.

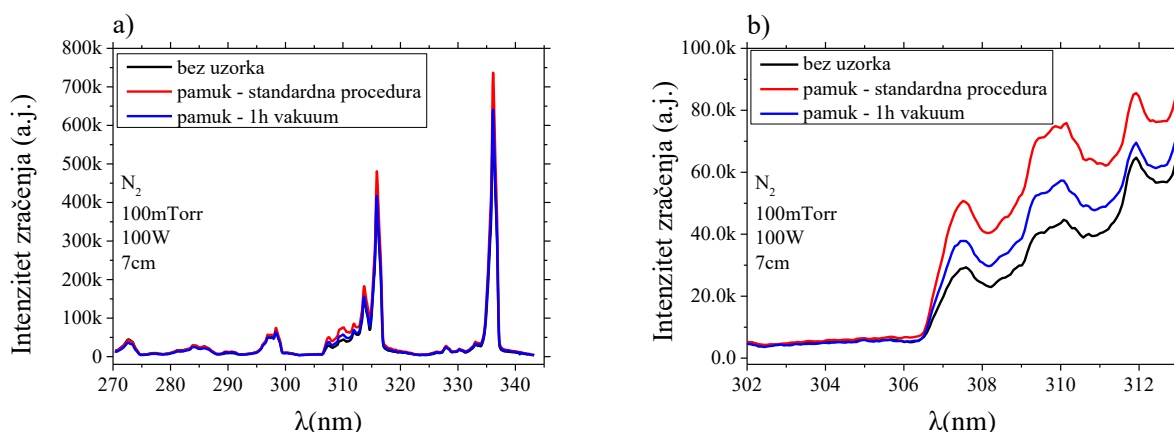

Slika 3.2.46 Poređenje spektara u azotnom pražnjenju a) u bliskom UV-u i b) u oblasti emitovanja OH traka, koji su dobijeni na pritisku od 100 mTorr N_2 , snazi od 100 W i međuelektrodnom rastojanju od 7 cm. Prazna komora (crna linija), standardno tretirani uzorak (crvena linija) i tretman uzorka koji je proveo 1h na pritisku od 10 mTorr (plava linija).

Spektri koji su dobijeni na tri različita načina su prikazani na slici 3.2.46. Bliska UV oblast zračenja je na slici 3.2.46 a) prikazana za merenja koja su obavljena tokom pražnjenja bez uzorka, crnom bojom, tokom standardnog tretmana pamučnog uzorka, crvenom bojom, i tokom tretmana uzorka koji je pre uključivanja plazme proveo sat vremena na pritisku od 10 mTorr. Jasno je vidljivo da je najveći intenzitet azotovih linija na 315,9 nm i 337,1 nm dobijen tokom standardnog tretmana pamučnog uzorka. Na slici 3.2.46 b) je uvećana oblast emisije OH traka, gde su razlike u emisiji između ova tri pražnjenja najizraženije. Najslabiji intenzitet emisije u ovoj oblasti je dobijen za komoru u kojoj se ne nalazi uzorak dok je najjača emisija dobijane tokom standardnog tretmana pamučnog uzorka. Ovo nas navodi na zaključak da je procesom dugotrajnog vakuumiranja smanjen doprinos makar jednog izvora OH grupa. Najverovatnije da je u pitanju voda koja se kao vlaga iz vazduha skupila u pamuku. Preostala emisija najverovatnije potiče od OH čestica koje se delovanjem plazme izdvajaju iz hemijske strukture celuloze.

Na slici 3.2.47 je prikazana evolucija emisije linije molekulskog azota na talasnoj dužini od 337,1 nm koja je snimljena u komori bez uzorka (crna linija) tokom standardnog tretmana pamučnog uzorka (crvena linija) i tokom tretmana uzorka koji je na minimalnom pritisku proveo sat vremena u komori pre početka tretmana (plava linija). Tokom tretmana uzorka ova emisiona linija je imala manji intenzitet za uzorak koji je sat vremena proveo u vakuumu. Razlika među njima se tokom tretmana od 300 s nije značajno promenila. S obzirom da je tretman rađen u azotu, razliku u intenzitetu emisije u ovom slučaju ne treba tražiti u količini raspoloživih molekula azota već u količini čestica koje bi procesima u plazmi mogle da dovedu do pobuđivanja N_2 molekula. Njihov izvor se, očigledno, nalazi i u uzorku a dugotrajnim izlaganjem vakuumu će njihova količina takođe biti smanjena.

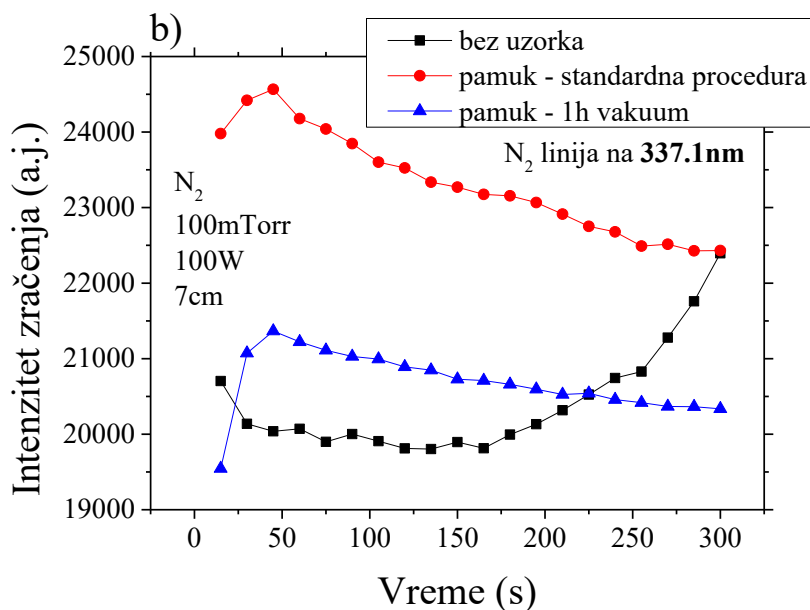

Slika 3.2.47 Evolucija azotove linije na 337.1 nm u azotnom pražnjenju na pritisku od 100 mTorr, snazi od 100 W i međuelektrodnom rastojanju od 7 cm. Prazna komora (crna linija), standardno tretirani uzorak (crvena linija) i tretman uzorka koji je proveo 1h na pritisku od 10 mTorr (plava linija).

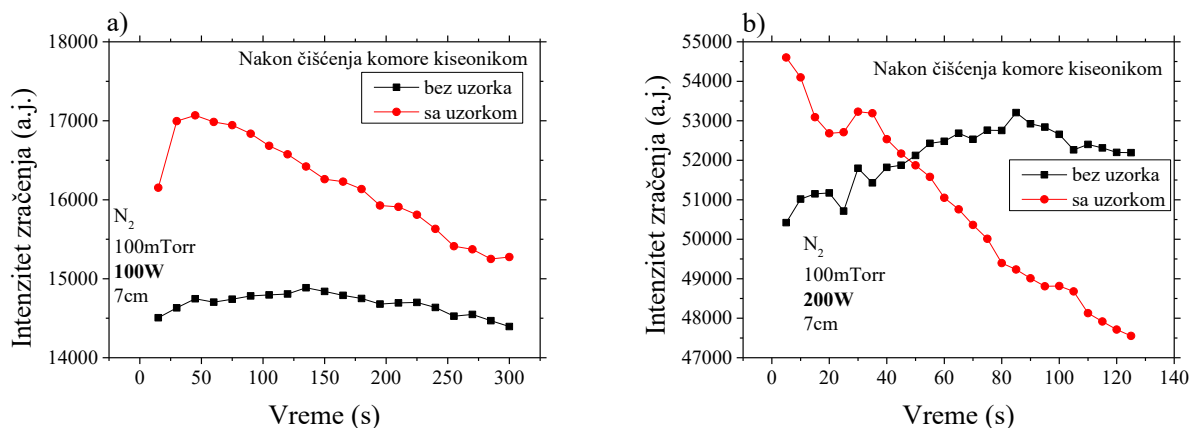

Slika 3.2.48 Evolucija azotove linije na 337.1 nm tokom pražnjenja sa i bez pamučnog uzorka u komori na pritisku od 100 mTorr, međuelektrodnom rastojanju od 7 cm i snazi od a) 100 W i b) 200 W.

Evolucija linije azotovog molekula na 337,1 nm tokom pražnjenja sa i bez pamučnog uzorka u komori ali nakon čišćenja komore kiseonikom je prikazana slici 3.2.48 za dve različite snage i rastojanje između elektroda od 7 cm. Na manjoj snazi evolucija je praćena 300 s (slika 3.2.48 a)) dok je zbog grejanja sistema na snazi od 200 W ona praćena tokom perioda od 130 s (slika 3.2.48 b)). Evolucija emisije tokom pražnjenja bez uzorka u komori ima nešto drugačiji oblik nakon procesa čišćenja, u odnosu na one do sada prikazane. Može da se primeti da će intenzitet linije da raste, do okvirno polovine ukupnog vremena, nakon čega dolazi do postepenog pada. Kada primenjena snaga iznosi 200W, bez uzorka u komori, dolazi do kontinualnog porasta intenziteta linije što najverovatnije ima veze sa porastom temperature. S druge strane, emisija tokom tretmana, nakon procedure čišćenja, ne izgleda suštinski drugačije. Ipak, razlika između maksimalne i minimalne vrednosti intenziteta

linije je pre procedure čišćenja iznosila 8,7 %, dok nakon procesa čišćenja komore kiseonikom taj pad iznosi 12 %.

Već smo ustanovili da će za iste uslove pražnjenja do izjednačavanja intenziteta emisije tokom tretmana i tokom pražnjenja bez uzorka u komori doći ranije ukoliko je snaga pražnjenja veća i ukoliko je rastojanje između elektroda manje. Možemo da uporedimo evoluciju linija za iste uslove pražnjenja (100 mTorr, 200 W, 130 s) ali za različita međuelektrodna rastojanja. Čišćenje komore kiseonikom je rađeno pre snimanja, za rastojanje od 7 cm (slika 3.2.48 b)) dok je za rastojanje od 4 cm snimanje rađeno bez procedure čišćenja (slika 3.2.30 b)). Iako bi bilo poželjno da smo bili u mogućnosti da uporedimo evolucije linije za ista međuelektrodna rastojanja, možemo da primetimo da će intenziteti emisije sa i bez uzorka u komori da se izjednače za duplo kraće vreme kada je snimanje rađeno posle procedure čišćenja.

3.2.3 LANGMIROVA SONDA

Merenja Langmirovom sondom su rađena kako bi se dobile lokalne vrednosti i prostorne raspodele veličina kao što su plazmeni potencijal, energija odnosno temperatura elektrona i koncentracija elektrona. Iz ovakvih merenja možemo proceniti uniformnost pražnjenja, što je važno tokom tretmana, ali se može omogućiti i saznanje kako će na ove parametre da uticati promena pritiska i snage pražnjenja. Iz literature je poznato da na određenim pd vrednostima, povećanjem pritiska, dolazi do promena distribucije elektrona po energijama, odnosno do prelaska sa stohastičkog na sudarno grejanje [200]. U sistemu poput našeg i sa rastojanjem između napajane i uzemljene elektrode od 7 cm do ove tranzicije dolazi na pritisku koji je nešto viši od 70 mTorr [201]. Kako bi moglo da se oceni da li je ova promena vidljiva u našem sistemu i kako ona utiče na pomenute parametre, pritisci na kojima su rađena merenja su odabrani tako da je jedan od njih značajno ispod te granice, 45 mTorr, gde je glavni mehanizam stohastično grejanje, dok je drugi, 200 mTorr, dovoljno iznad te granice tako da je dominantan sudarni mehanizam grejanja.

Prostorna raspodela plazmenog potencijala je prikazana na slici 3.2.49. Rastojanje na graficima se meri od ose cilindra čije osnove su elektrode a isprekidanim linijama je označena ivica cilindra. Merna tačka sa najvećim udaljenjem od centra se nalazi oko 1 cm van prostora koji je ograničen spoljnim ivicama elektroda. Treba napomenuti da greška prilikom određivanja plazmenog potencijala iznosi 10 %. Najveća vrednost ove veličine je dobijena na centralnoj poziciji i opadala je sa udaljenjem od centra. Ova zavisnost, je bila nešto izraženija na pritisku od 200 mTorr na kome su dobijene i nešto više vrednosti plazmenog potencijala. Takođe, U_{pl} je na svim mernim pozicijama i pritiscima bio veći kada je primenjena snaga pražnjenja bila veća.

Plan-paralelno kapacitivno spregnuto pražnjenje

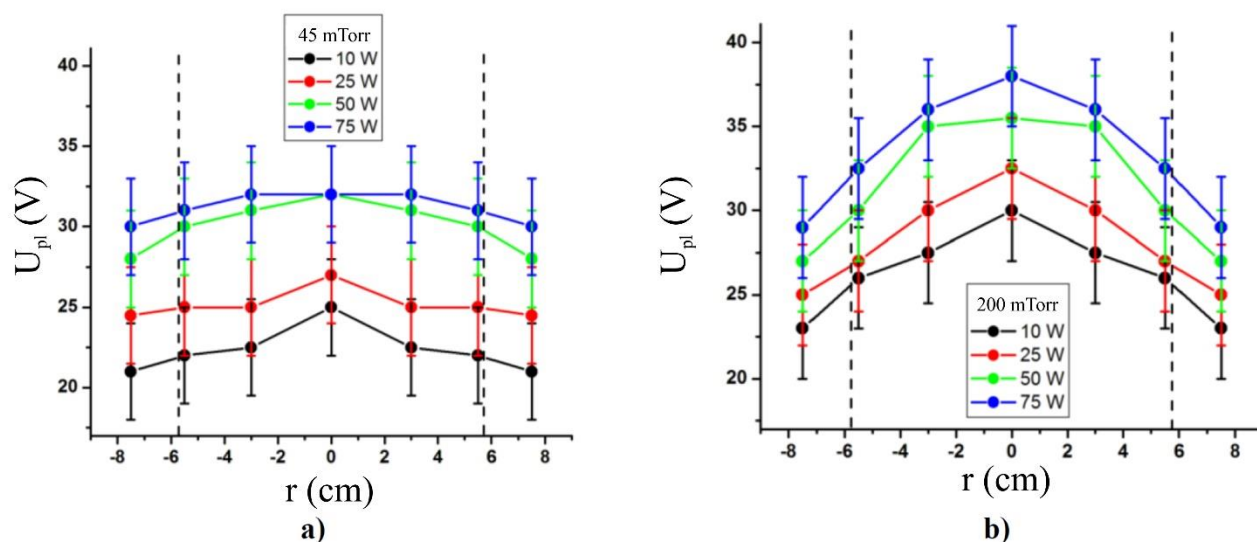

Slika 3.2.49 Prostorna raspodela plazmenog potencijala snimljena Langmirovom sondom na 4 snage pražnjenja (10, 25, 50 i 75 W) i na pritiscima od a) 45 mTorr i b) 200 mTorr [202].

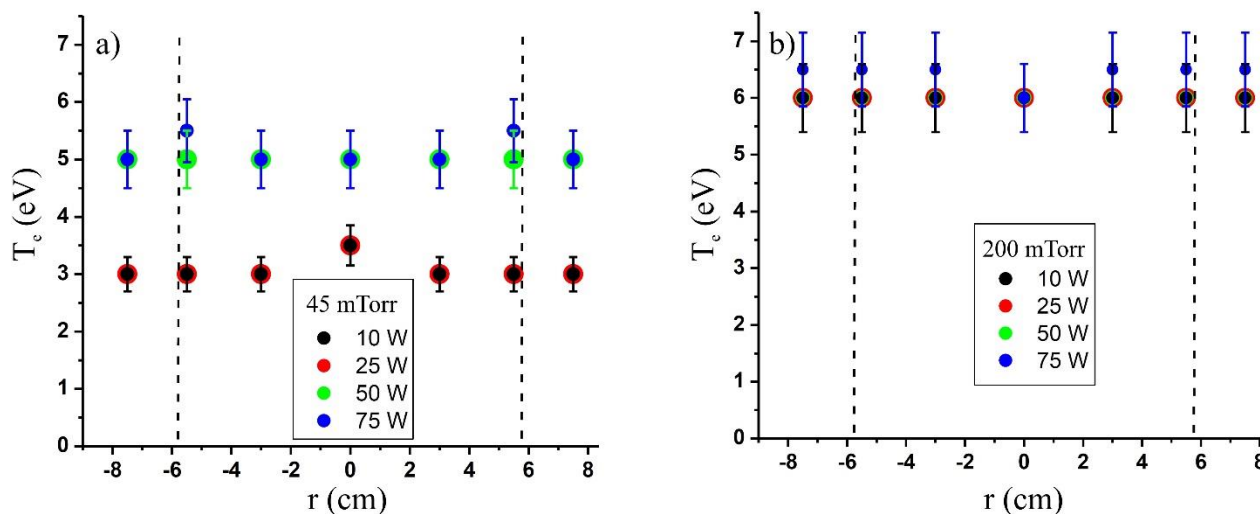

Slika 3.2.50 Prostorna raspodela temperature elektrona, izražena u eV, dobijena za 4 različite snage (10, 25, 50 i 75 W) i na pritiscima od a) 45 mTorr b) 200 mTorr [202].

Temperature elektrona se dobijaju iz njihove raspodele po energijama. Kao što je rečeno, te raspodele su aproksimirane Maksvelovim sve do energije prvog pobuđenog stanja argona. Prostorna raspodela temperature elektrona koja je dobijena ovom procedurom je prikazana na slici 3.2.50 za četiri snage i dva različita pritiska, 45 mTorr i 200 mTorr. Veće temperature elektrona su zabeležene na većem pritisku, ali je dobijeno da ona praktično i ne zavisi od tačke prostora u kojoj je merenje rađeno, odnosno da T_e ima uniformnu prostornu distribuciju. Promena snage dovodi do povećanja T_e samo na najvećim primenjenim snagama a ova zavisnost je uočljivija na manjem pritisku. Na centralnoj poziciji i na pritisku od 200 mTorr je dobijena identična temperatura za sve primenjene snage, tako da možemo da kažemo da u ovakvom tipu reaktora energiju elektrona, u najvećoj meri,

određuje pritisak. Ovaj rezultat je kontra-intuitivan jer se očekuje da energija elektrona bude veća na manjem pritisku. Međutim, kao što je Godijak pokazao [200], na malim pritiscima će tokom pražnjenja u argonu najveći deo elektrona imati energije od svega nekoliko eV. Povećanjem pritiska će vrh raspodele da se širi i da se pomera ka višim energijama što može da utiče na srednju energiju elektrona, odnosno na njihovu temperaturu, tako što će da je poveća.

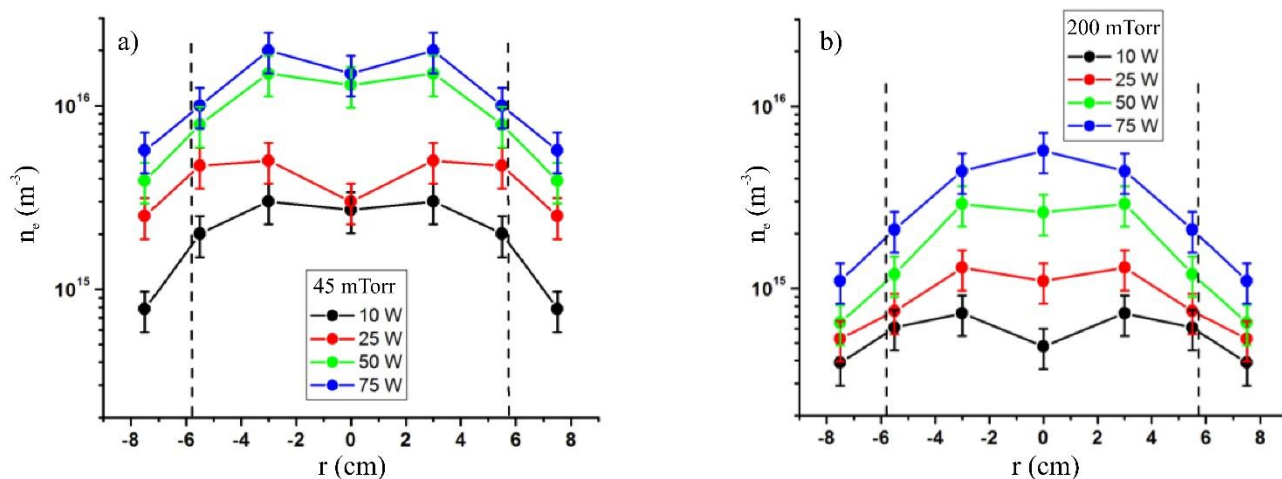

Slika 3.2.51 Prostorna raspodela koncentracije elektrona dobijena za 4 različite snage (10, 25, 50 i 75 W) i na pritiscima od a) 45 mTorr i b) 200 mTorr [202].

Koncentracija elektrona u zavisnosti od centralnog rastojanja je prikazana na slici 3.2.51 za 4 različite snage pražnjenja i dva pritiska. Kao što je i očekivano, koncentracija elektrona će da bude veća kada je primenjena veća snaga pražnjenja. Sa druge strane, srednji slobodni put elektrona će biti veći na manjem pritisku. Odnosno električno polje će na elektron delovati duže između dva sudara, što za posledicu daje veći broj elektrona velike energije. Ovakvi elektroni mogu da imaju dovoljno energije da izvrše nove jonizacije što kao rezultat daje veću koncentraciju elektrona na manjem pritisku.

Na slici 3.2.53 su crnim linijama predstavljene dve funkcije raspodele dobijene direktnim diferenciranjem iz V-I karakteristika koje su izmerene u pražnjenjima u argonu, na istoj primenjenoj snazi ali na različitim pritiscima [202]. Razlog za izobličenje ovih krivi u oblasti između 0 i 10 eV može da leži u nedovoljnom odnosu površina referentne sonde i vrha sonde, koji bi u idealnom slučaju trebalo da iznosi $\sqrt{M/m}$ gde je M masa jona. Kako bi se kompenzovao nedovoljan odnos površina sonde i referentne elektrode, u procesu obrade podataka je korišćena tehnika uvođenja efektivnog otpornika u kolo sonde, R_{eff} . Naglašavamo da otpornici nisu u fizičkom smislu priključivani na aparaturu, već su u kolo „ubačeni“ tokom proračuna. Na levoj strani slike 3.2.53 su crvenom linijom obeležene krive za otpor od 200 Ω a plavom za 500 Ω , na desnoj strani slike crvena boja odgovara otporu od 2 k Ω dok za plavu važi da je $R_{eff}=5$ k Ω . Za niži pritisak se povećanjem vrednosti otpornika raspodela sve više približava idealnoj i za vrednosti između 5 i 11,56 eV je u potpunosti Maksvelova. Na energijama većim od te počinju odstupanja jer je se tu nalazi prvo pobuđeno stanje argona što znači da sudari elektrona i atoma više nisu elastični. Temperatura elektrona u uslovima pražnjenja na desnoj strani slike iznosi 6 eV i jasno je da plava kriva nije odgovarajuća. Za idealna merenja bi, ipak, bilo potrebno da površina referentne elektrode bude veća.

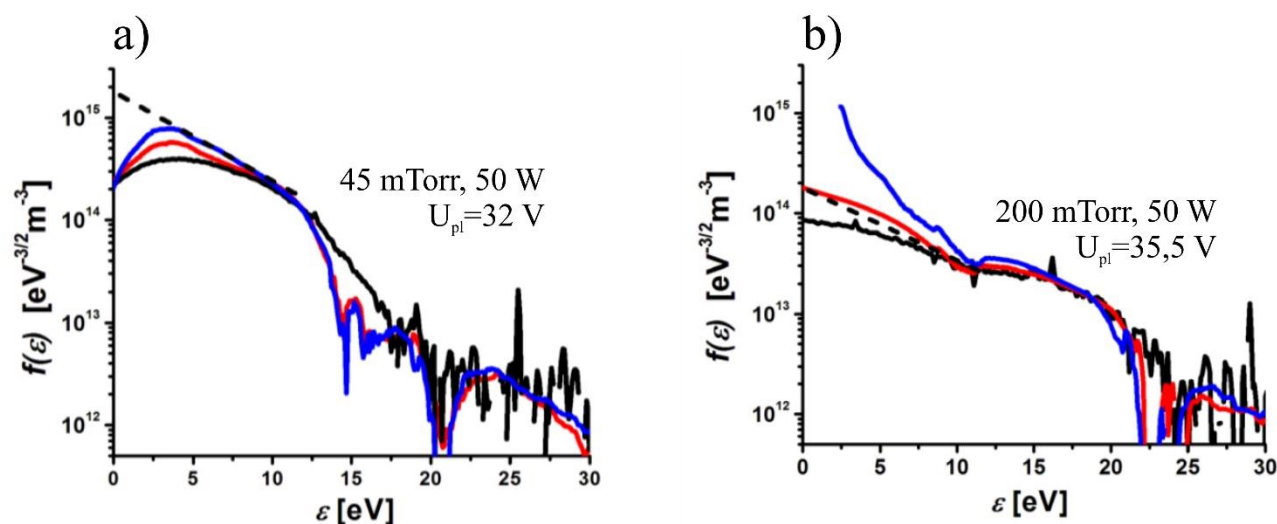

Slika 3.2.53 Funkcije raspodele elektrona po energijama. Crna linija je dobijena direktnom diferencijacijom. Računskom metodom ubacivanja efektivnog otpora u kolo su dobijene raspodele obeležene crvenom i plavom bojom. Vrednosti R_{eff} su bile a) 200 Ω (crvena) i 500 Ω (plava) i b) 2 k Ω (crvena) i 5 k Ω (plava).

3.2.4 ZAKLJUČAK

Treća glava ove disertacije bila je posvećena dijagnostici reaktora plan paralelne geometrije. Sistem je napajan istim izvorom snage kao asimetrični reaktor velike zapremine. Derivativnim sondama su ispitivane električne osobine pražnjenja, metodom optičke emisije spektroskopije je ispitivano na koji način prisustvo tretiranog uzorka utiče na plazmu dok je Langmirovom sondom ispitivana uniformnost pražnjenja u radijalnom smeru.

Derivativnim sondama su ispitivane električne osobine sistema za međuelektrodna rastojanja od 4 cm i 7 cm. Ispitivanja su rađena za pražnjenja u argonu na pritiscima od 45 mTorr i 200 mTorr, za snage između 10 W i 75 W ali i za pražnjenja u azotu na pritisku od 100 mTorr na nominalnim snagama između 25 W i 200 W. Podaci su obrađivani na isti način kao i tokom merenja u asimetričnom reaktoru. Tokom merenja u argonu odstupanje strujnih signala od pravilne sinusoide je, za oba rastojanja između napajane i uzemljene elektrode, bilo vrlo izraženo čak i za najmanje primenjene snage. Odstupanja su bila izraženija na većim nominalnim snagama. Ispitivanjem frekventnog sastava strujnog signala je zaključeno da do pojave nepravilnosti dolazi zbog izraženog drugog harmonika strujnog signala čiji je intenzitet na većini mernih uslova bio uporediv sa osnovnim harmonikom, dok ga je na najvećim snagama čak i premašivao. S druge strane, naponski signali su bili gotovo savršenog sinusoidnog oblika. Na manjem pritisku, RMS vrednosti napona nisu zavisile od rastojanja između elektroda ali su izmerene nešto veće vrednosti struje na rastojanju od 7 cm. Na pritisku od 200 mTorr su na većem rastojanju izmerene nešto veće RMS vrednosti i struje i napona. Posledično je, u najvećem delu mernih parametara, dobijena veća efikasnost sistema za veće rastojanje između elektroda a njena vrednost se kretala između 54 % i 87 %. Tokom merenja u azotu su dobijene vrlo slične zavisnosti struje i napona i napona od vremena, ali i sličan frekventni sastav signala. Efikasnost sistema se kretala između 65 % i 85 % i, takođe, je bila veća za veće rastojanje između elektroda.

Ispitivanje metodom optičke emisije spektroskopije je rađeno praćenjem vremenske evolucije emisionih linija na dva različita rastojanja, 4 cm i 7 cm, za pražnjenja kada u komori nije bilo uzorka i tokom tretmana pamučne tkanine. Intenzitet emisije je veći tokom tretmana nego kad u

komori nije bilo uzorka. Na početku tretmana je primetan porast emisije a nakon određenog vremena, zavisno od uslova tretmana, dolazi do opadanja intenziteta emisije linije sa čela Druge pozitivne trake molekula N₂. Razlog za opadanje intenziteta emisije predstavlja interakcija pobuđenih molekula azota sa površinom usled čega dolazi do efektivnog smanjenja koncentracije emitera u pražnjenju. Efekat je pokazan za sve različite parametre tretmana (snaga i međuelektrodno rastojanje) i njegov intenzitet se menjao u skladu sa jačinom intenziteta tretmana tekstila. Radi provere hipoteze je praćena evolucija iste azotove linije za iste uslove pražnjenja tokom tretmana uzoraka koji su napravljeni od materijala različite površinske strukture: PET tkanina i staklo. Emisija se kako za stakleni tako i za uzorak od PET tkanine nije menjala u toku vremena. Dodatno je, poređenjem spektara tokom tretmana uzorka od ova tri materijala, primećeno da OH emisiona traka postoji samo kada se u komori nalazio pamučni uzorak. Intenzitet zračenja u oblasti emisije OH trake je upoređen za situaciju kada u komori nije bilo uzorka, tokom standardnog tretmana i tokom tretmana uzorka koji u vakuumu proveo sat vremena. Vrlo slične vrednosti su dobijene za praznu komoru i uzorak koji je sat vremena bio vakuumu dok je tokom standardnog tretmana emisija bila intenzivnija. Treba imati na umu da je struktura pamuka takva da se delovanjem plazme na površinu uzorka iz nje mogu izdvojiti OH radikali koji će doprineti tome da emisiona traka bude intenzivnija tokom tretmana pamučnog uzorka nego kada je komora bila prazna.

Tokom merenja Langmirovom sondom je zbog nedovoljno velike razlike površina referentne sonde i samog vrha sonde, tokom obrade, korišćena metoda efektivnog otpora koji se računskim putem uključuje u električno kolo sistema. Ispitivane su osobine pražnjenja kao što su plazmeni potencijal, temperatura i koncentracija elektrona. Njihovi prostorni profili, odnosno zavisnost ovih veličina od udaljenosti od centralne ose kružnih elektroda je merena na dva različita pritiska (45 mTorr i 200 mTorr) i na 4 različite snage (10 W, 25 W, 50 W i 75 W). Plazmeni potencijal je bio praktično uniforman tokom merenja na pritisku od 45 mTorr dok je na pritisku od 200 mTorr njegova vrednost opadala sa udaljavanjem od centralne ose sistema. Temperatura elektrona je praktično nezavisna od pozicije na kojoj se radilo merenje ali je bila veća kada je i pritisak u komori bio veći. Koncentracija elektrona ima nešto komplikovaniju zavisnost od rastojanja od centralne ose sistema ali je za sve uslove primetan njen značajan pad u oblasti na granici prostora koji je definisan spoljnim ivicama elektroda.

3.3 PRIMENE PLAN-PARALELNOG PRAŽNJENJA U TRETMANU TEKSTILA

U ovoj glavi će biti predstavljeni rezultati tretmana pamučne tkanine sa ciljem nanošenja mikrokapsula na njenu površinu. Rezultati će biti analizirani kroz način koji je uobičajen u tekstilnoj industriji, odnosno kroz promenu K/S vrednosti uzorka. Slovom K je obeležen koeficijent apsorpcije, a slovom S koeficijent rasejanja. Ova veličina se još zove i prinos boje, njenom promenom može da se proceni koliko je uzorak uspešno obojen odnosno, u našem slučaju, da li se na njegovoj površini nalazi više ili manje mikrokapsula. Veći intenzitet ove veličine znači da je uzorak uspešnije obojen. Biće prikazane fotografije tretiranih i netretiranih uzoraka koje su napravljene elektronskim mikroskopom a biće predstavljeni i rezultati FTIR analize površine uzoraka.

3.3.1 EKSPERIMENTALNA POSTAVKA

Za vakuumiranje sistema, predaju snage plazmi i spektroskopska snimanja je korišćena ista oprema koja je opisana u poglavlju 3.1. Kao radni gas je u ovim eksperimentima korišćen azot.

Plan-paralelno kapacitivno spregnuto pražnjenje

Uzorci od beljenog pamuka su bili postavljeni na donju, uzemljenu, elektrodu. Njihove dimenzije su iznosile 5X5 cm ili 7x7 cm. Kako bi se obezbedio ravnomeran tretman cele površine uzorka, njihovi krajevi su lepljivom trakom bili dodatno pričvršćeni za podlogu. Nakon postavljanja uzorka, pritisak u komori je prvo obaran do 30 mTorr, posle čega je odgovarajućim protokom azota podešavan na željenu vrednost. Trajanje ove procedure iznosi oko 15 min. Parametri kola za prilagođenje su bili unapred podešeni tako da su uključivanjem pražnjenja poslata i reflektovana snaga već bili u najboljem mogućem odnosu. Takođe je i vrednost nominalne snage bila unapred podešena kako se vreme tretiranja ne bi trošilo na podešavanje električnih parametara pražnjenja, odnosno kako bi tokom tog perioda oni sve vreme bili približno konstantni. Pre vađenja uzorka iz komore, nakon tretmana, je u nju potrebno upustiti vazduh.

3.3.2 REZULTATI TRETMANA

Tokom ovih tretmana su korišćeni isti uslovi pražnjenja kao i tokom eksperimenata koji su opisani u poglavlju 3.2.2. Odnosno, korišćena je azotna plazma na pritisku od 100 mTorr. Primenjena snaga je varirana između 25 i 200 W a rastojanje između napajane i uzemljene elektrode je moglo da se podešava između 4 i 7 cm.

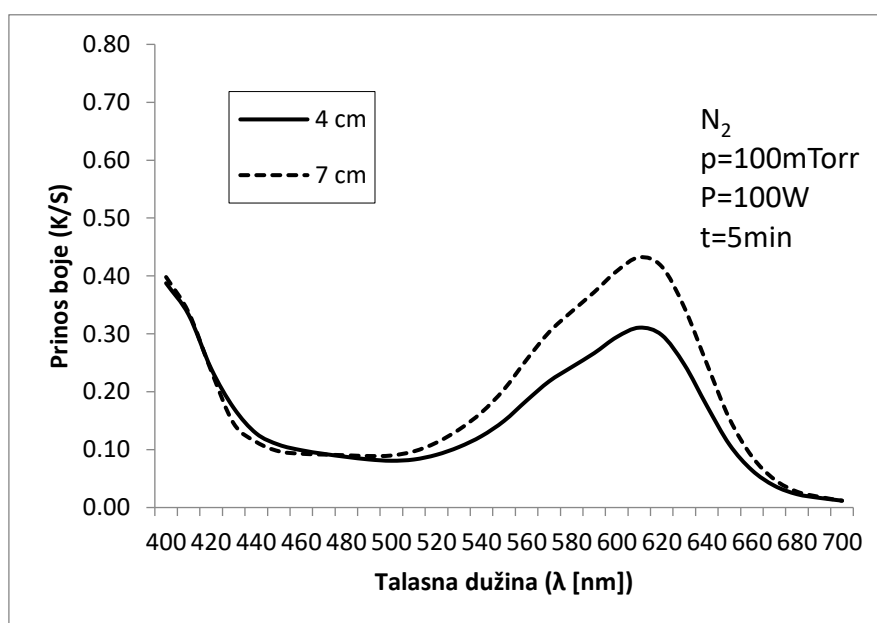

Slika 3.3.1 K/S vrednosti dobijene na pamučnoj tkanini nakon 5 minuta tretmana u azotnoj plazmi na pritisku od 100 mTorr sa primenjenom snagom od 100 W i sa međuelektrodnim rastojanjem od 4 cm i 7 cm.

Poređenje K/S vrednosti koje su izmerene na uzorcima koji su tretirani 5 minuta azotnom plazmom na pritisku od 100 mTorr i sa primenjenom snagom od 100 W, za dva različita rastojanja između napajane i uzemljene elektrode je prikazano na slici 3.3.1. U poglavlju 3.2.2 smo pokazali da je intenzitet zračenja linije azotovog molekula na 337,1 nm bio veći kada je međuelektroдно rastojanje iznosilo 4 cm. Ipak, uzorak koji je tretiran sa rastojanjem između elektroda od 7 cm je apsorbovao veću količinu mikrokapsula. Mogući razlog za ovakav rezultat je da je intenzivnija plazma, koja nastaje smanjenjem rastojanja između elektroda, dovela ili do oštećenja uzorka ili je sa

Plan-paralelno kapacitivno spregnuto pražnjenje

njegove površine, cepanjem hemijskih veza, odvojila previše funkcionalnih grupa za koje bi se vezale mikrokapsule.

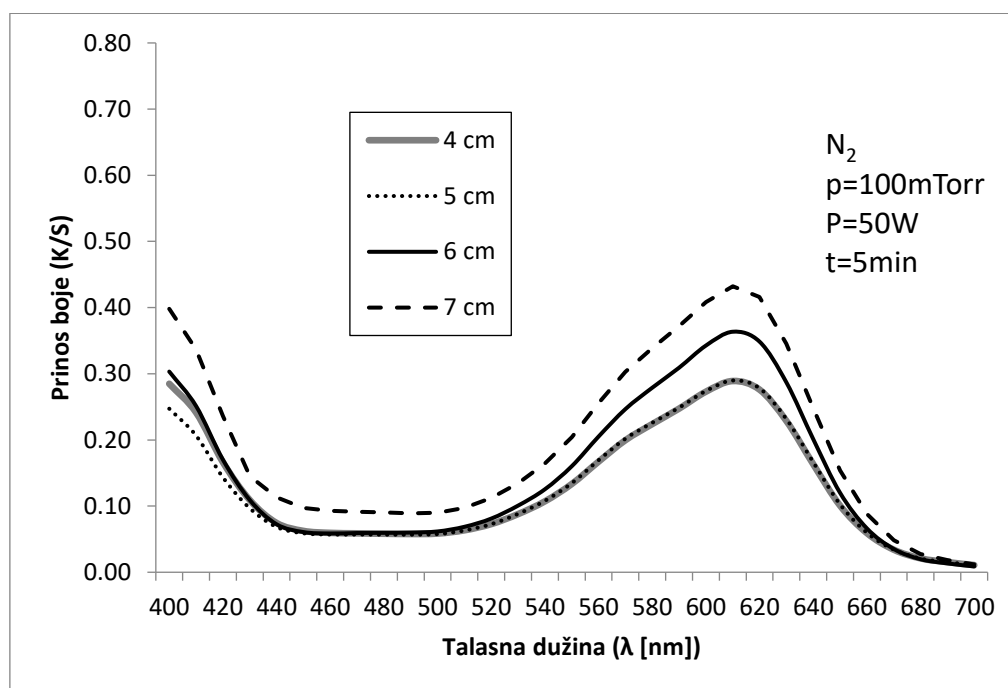

Slika 3.3.2 K/S vrednosti dobijene na pamučnoj tkanini nakon 5 minuta tretmana u pražnjenju u azotu na pritisku od 100 mTorr sa primenjenom snagom od 100 W ali sa različitim međuelektrodnim rastojanjem (4, 5, 6 i 7 cm)

Promene K/S vrednosti u zavisnosti od rastojanja između uzemljene i napajane elektrode tokom petominutnih tretmana azotnom plazmom na pritisku od 100 mTorr i sa snagom pražnjenja od 50 W su predstavljene na slici 3.3.2. Slično kao i tokom pražnjenja na 100 W, uspešnije nanošenje mikrokapsula je zabeleženo za one uzorke koji tretirani sa većim međuelektrodnim rastojanjem. Na većim rastojanjima je, kao što je pokazano u glavi 3.2.2, emisija azota bila manja, što znači da je pamuk toliko osetljiv da već na ovim uslovima (50 W, 5 min), ukoliko je rastojanje između napajane elektrode i uzorka previše malo, plazma može da promeni uzorak na takav način da se mogućnost apsorpcije mikrokapsula smanjuje.

Plan-paralelno kapacitivno spregnuto pražnjenje

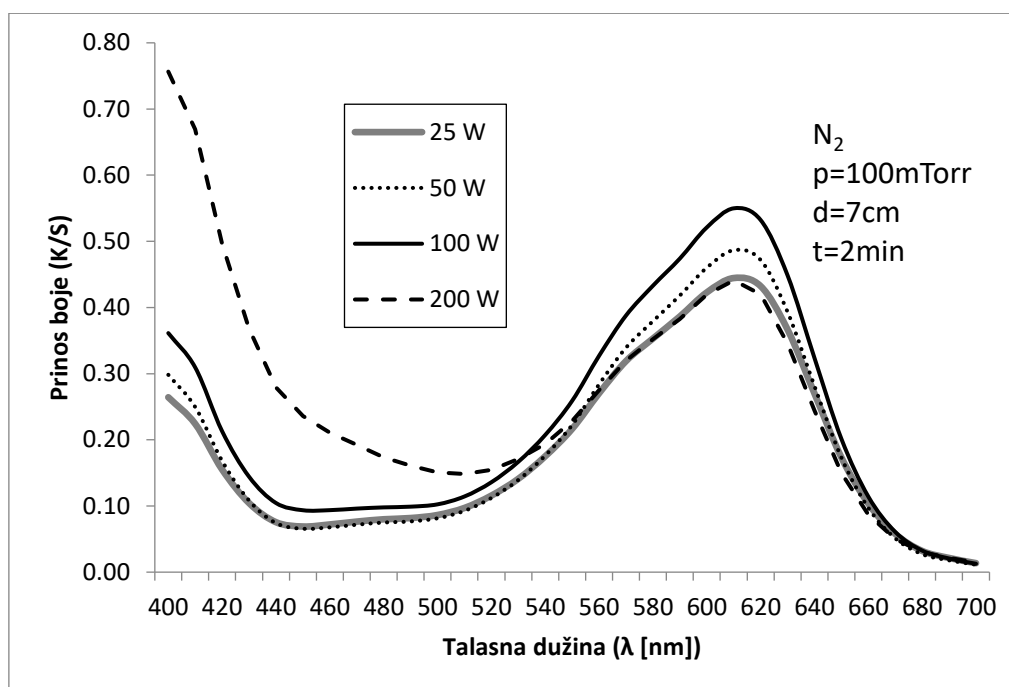

Slika 3.3.3 Poređenje efekata snage tretmana na K/S vrednosti uzoraka. Rastojanje između elektroda je podešeno na 7 cm, pritisak na 100 mTorr a vreme tretmana iznosi 2 min

Efekat primenjene snage tokom tretmana uzoraka na promenu boje je testiran za snage od 25 W, 50 W, 100 W i 200 W. S obzirom da je grejanje opreme na snazi od 200 W bilo veoma izraženo, tretman na toj snazi nije mogao da se radi duže od 2 min. Kako bi rezultati bili međusobno uporedivi, tretman je i na svim ostalim snagama trajao 120 s a rezultat je prikazan na slici 3.3.3. Najveća K/S vrednost je dobijena tokom tretmana na snazi od 100 W. Treba primetiti da je dobijena vrednost veća nego kada je na istoj snazi i na istom pritisku tretman trajao 5 min. Ova činjenica ide u prilog hipotezi da se, zavisno od uslova, sa tretmanom može preterati i da će ukupni efekti biti lošiji. Previše intenzivni uslovi se dobijaju kad do površine uzorka dolazi preveliki broj aktivnih čestica, kada je njihova energija prevelika, što se postiže malim rastojanjem između elektroda ili velikom snagom pražnjenja, i ukoliko je vreme tretmana predugačko. Tokom dvominutnih tretmana je, u odnosu na uzorke koji su tretirani sa 100 W, nešto manje intenzivna boja dobijena posle tretmana na snazi od 50 W. Najmanja K/S vrednost je zabeležena za uzorke koji su tretirani na snazi od 25 W, koja nije dovoljna da se njihova površina aktivira na odgovarajući način, i za one koji tretirani na snazi od 200 W. Takođe, uzorak koji tretiran na najvećoj snazi je i pre nanošenja mikrokapsula imao vidljivo promenjenu boju, požuteo je, što znači da je došlo do oštećenja i da je ova snaga prejaka za tretman pamučnih uzoraka.

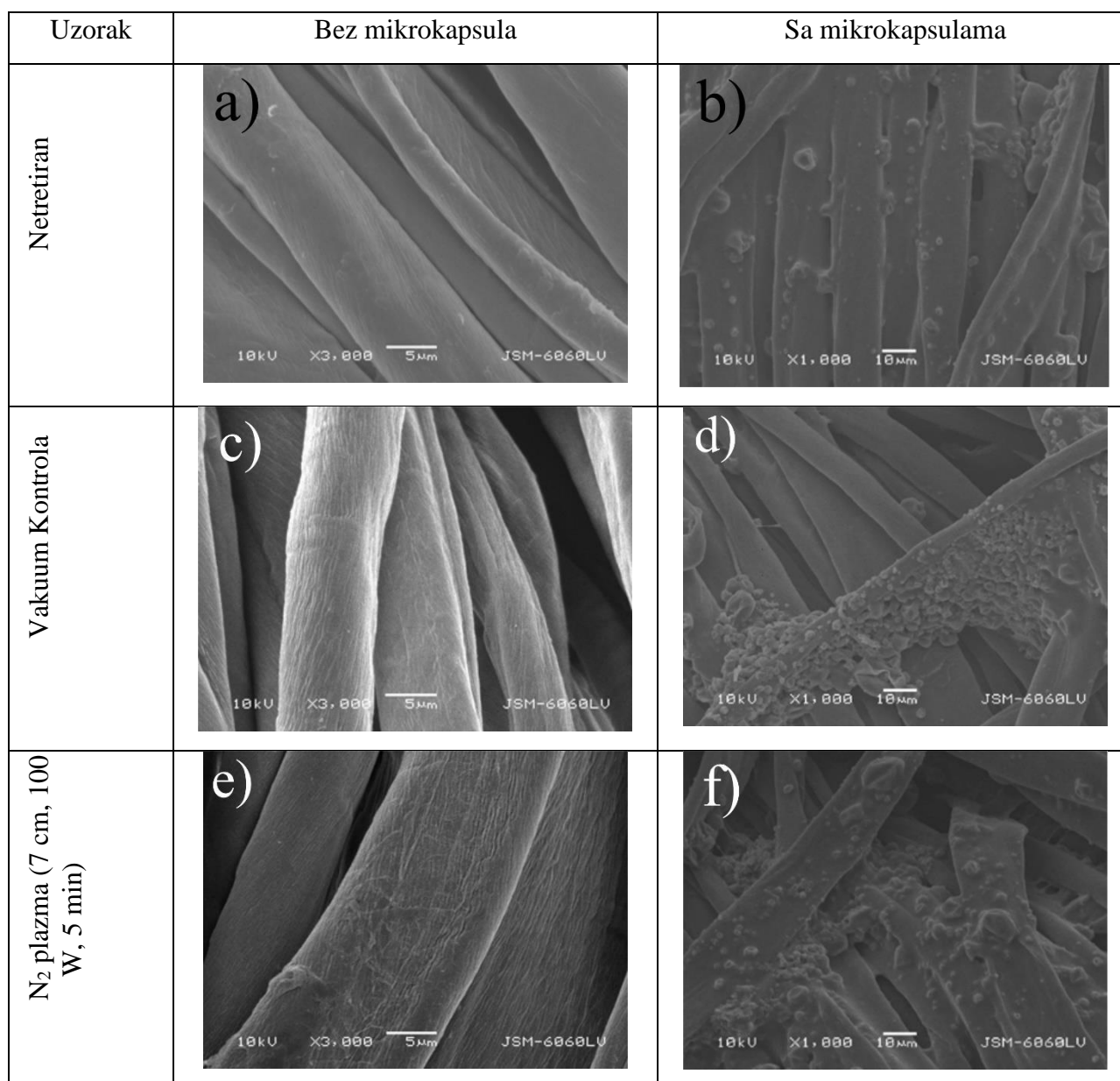

Slika 3.3.4 Fotografije, napravljene elektronskim mikroskopom (SEM), uzoraka pre (a, c i e) i posle (b, d i f) nanošenja mikrokapsula. Prikazana je struktura uzoraka koji nisu uopšte tretirani (a i b), onih koji su bili samo u vakuumu (c i d) i onih koji su tretirani u plazmi (e i f).

Na slici 3.3.4 nalaze se fotografije uzoraka koje su napravljene elektronskim mikroskopom. Uporedno su prikazani uzorci pre i posle procesa nanošenja mikrokapsula za tri specifična slučaja. Netretirani uzorci se nalaze na gornjem delu slike, uzorci koji su „tretirani“ samo tako što su u vakuumu proveli određeno vreme se nalaze u centralnom delu slike dok se na dnu slike nalaze snimci uzoraka koji su tretirani u azotnoj plazmi 5 min na pritisku od 100 mTorr i sa primenjenom snagom od 100 W. Rastojanje između elektroda, tokom tretmana ovih uzoraka, je iznosilo 7 cm. Vlakna uzoraka koja nisu tretirana i onih koji su bili u vakuumu bez uključivanja plazme izgledaju praktično identično. Nešto je drugačiji uzorak koji je prošao tretman. Uzdužne brazde su vidljivo dublje, primetno je postojanje i poprečnih brazdi dok celokupna površina ima nepravilniju morfologiju. Nakon procedure nanošenja mikrokapsula, na netretiranom i uzorku koji je samo vakuumiran se nalazi malo mikrokapsula koje su, takođe, i vrlo neravnomerno raspoređene. Sa druge strane, na tretiranom uzorku se nalazi znatno više, ravnomerno raspoređenih, mikrokapsula.

Plan-paralelno kapacitivno spregnuto pražnjenje

Za azotnu plazmu se zna da u površinu pamučnih uzoraka, tokom tretmana, može da ugradi grupe kao što su amin, amid ili imid [203], [204]. Na slici 3.3.5 je prikazan FTIR spektar koji je dobijen sa tri različita uzorka. Jedan je kontrolni, odnosno netretiran, dok su druga dva tretirana u azotnoj plazmi po pet minuta na pritisku od 100 mTorr, primenjenoj snazi od 100 W sa rastojanjem između napajane i uzemljene elektrode od 4 i 7 cm. Linija koja se u spektru apsorbanse pojavljuje na 1545 cm^{-1} se pripisuje deformaciji N-H grupe [205]. Dodatno, apsorpcioni pojas koji se pojavljuje na 1725 cm^{-1} odgovara asimetričnim vibracijama karbonilne grupe [206]. Sa slike 3.3.5 se vidi da se nakon tretmana na većem rastojanju između elektroda u spektru pojavljuju dve linije, na 1739 i 1714 cm^{-1} umesto jedne, na 1725 cm^{-1} .

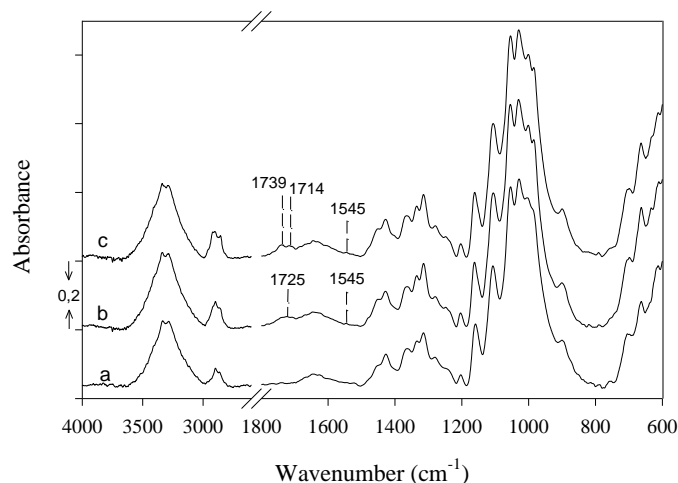

Slika 3.3.5 FTIR spektar uzoraka koji a) nisu tretirani, b) koji su tretirani azotnom plazmom sa rastojanjem između elektroda od 4 cm i c) sa međuelektrodnim rastojanjem od 7 cm

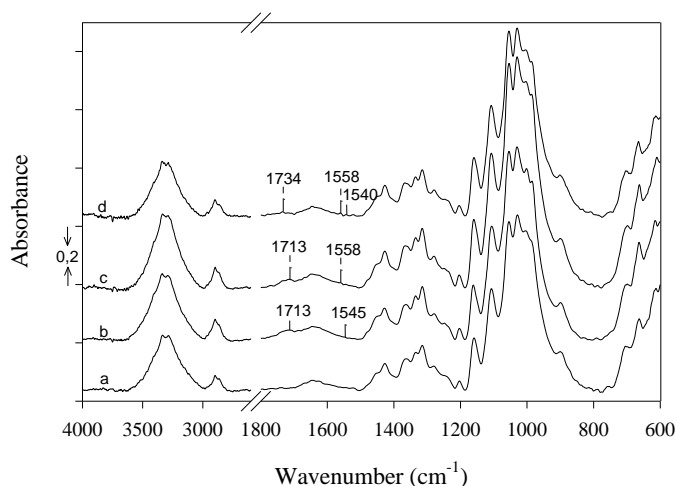

Slika 3.3.6 FTIR spektar uzoraka koji a) nisu tretirani i koji su tretirani u azotnoj plazmi na snagama od b) 200 W, c) 100 W i d) 25 W.

Poređenje FTIR spektara koji su dobijeni sa uzoraka tretiranih na različitim snagama (25, 100 i 200 W) se nalazi na slici 3.3.6. Dužina tretmana je za sve uzorke iznosila 2 min dok je pritisak bio podešen na 100 mTorr. Apsorpcione linije koje se u ovim spektrima pojavljuju na 1540, 1545 i 1558 cm^{-1} odgovaraju deformacijama N-H grupe (amin II) dok linije koje se primećuju na 1713 i 1734 cm^{-1} pripadaju apsorpcionoj traci koja nastaje asimetričnim istežanjem karbonilne grupe. Sa

povećanjem snage na kojoj su tretirani uzorci dolazi i do povećanja intenziteta linije 1713 cm^{-1} ali i do opadanja one koja se nalazi na 1558 cm^{-1} . Na najmanjoj snazi, od 25 W , primećuje se i dodatna linija na 1545 cm^{-1} .

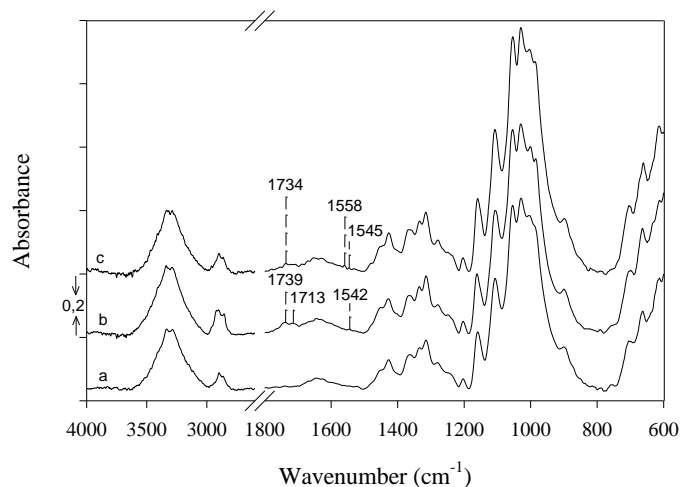

Slika 3.3.7 FTIR spektar uzoraka koji a) nisu tretirani i koji su tretirani u azotnoj plazmi na pritisku od b) 100 mTorr i c) 200 mTorr.

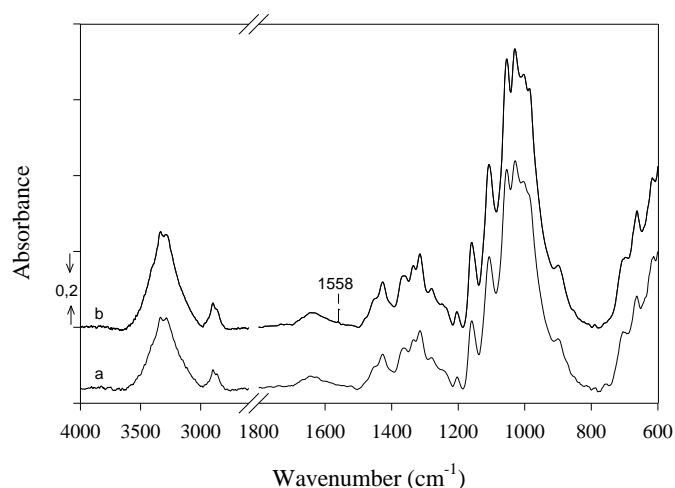

Slika 3.3.8 FTIR spektar uzoraka koji a) nisu tretirani i b) koji su bili izloženi samo vakuumu.

Efekat pritiska na kome je rađen tretman uzoraka na FTIR spektar dobijen sa njihove površine je prikazan na slici 3.3.7. Tretman je trajao 5 min sa primenjenom snagom od 100 W . Linije koje odgovaraju N-H deformacijama se na uzorku koji je tretiran na 100 mTorr vide na 1542 cm^{-1} dok se kod uzorka koji je tretiran na višem pritisku, od 200 mTorr, one vide na 1558 i 1545 cm^{-1} . Prisustvo karbonilnih grupa na površini uzoraka se vidi kao postojanje linija na 1739 i 1713 cm^{-1} za onaj koji je tretiran na 100 mTorr i na 1734 cm^{-1} za onaj koji je tretiran na 200 mTorr.

Poređenje FTIR spektara koji su dobijeni sa netretiranog uzorka i uzorka koji je na pritisku od 100 mTorr proveo 10 min je prikazano na slici 3.3.8. Jedina uočena razlika je pojava linije na 1558 cm^{-1} koja označava prisustvo N-H grupe u uzorku. U ovim uzorcima, koji nisu bili u pražnjenju, nije uočena pojava linija koja bi označila prisustvo karbonilnih grupa, što znači da je za njihovo nastajanje na pamuku neophodno da uzorci budu izloženi delovanju plazme.

3.3.3 Zaključak

Tretman tekstila sa ciljem nanošenja mikrokapsula je rađen u pražnjenju u azotu na pritisku od 100 mTorr na snagama između 25 W i 200 W. Rastojanje između napajane i uzemljene elektrode je bilo menjano između 4 cm i 7 cm. K/S testom je pokazano da će za iste uslove pražnjenja, vreme i snagu tretmana, tretmani biti uspješniji ukoliko je razmak između elektroda veći. Istim testom je pokazano da će, za isto rastojanje između elektroda i jednako vreme tretmana, uzorak apsorbovati više mikrokapsula ukoliko je tretman rađen sa većom primenjenom snagom. Međutim, treba voditi računa o tome da sa prevelikom snagom pražnjenja može da dođe do oštećenja uzorka što značajno smanjuje kvalitet tretmana. U našim eksperimentalnim uslovima je do oštećenja tkanine došlo kada je primenjena snaga iznosila 200 W. Dodatno poređenje uzoraka je rađeno snimanjem njihovih površina, elektronskim mikroskopom SEM tipa. Snimci su napravljeni pre i posle postupka nanošenja mikrokapsula za uzorke koji nisu bili tretirani, za uzorke koji su na niskom pritisku u azotu proveli određeno vreme i za uzorke koji su tretirani azotnom plazmom. Uzorak koji nije tretiran i uzorak koji je bio samo u vakumu su imali veoma sličnu morfologiju površine i količinu apsorbovanih mikrokapsula. Na površini tretiranog tekstila je vidljiva promena, povećan je broj i dubina brazdi. Takođe, apsorbovano je više mikrokapsula. Površina je analizirana još i primenom FTIR metode. Pokazano je da nakon tretmana dolazi do povećanja linija koje odgovaraju karbonilnim i N-H grupama. Upoređeni su FTIR spektri uzoraka koji nisu tretirani, koji su na niskom pritisku u azotu proveli određeno vreme i koji su tretirani plazmom. Linije karbonilnih grupa su primećene samo u uzorcima koji su tretirani plazmom. Zanimljivo je da su N-H grupe nastale i na površini uzoraka koji su tretirani i na površini tekstila koji je bez uključivanja plazme proveo određeno vreme na niskom pritisku u azotu.

3.4 ZAKLJUČAK

U ovoj glavi su prikazani rezultati dijagnostike pražnjenja u reaktoru plan paralelne geometrije i prikazani su rezultati tretmana pamučnih uzoraka. Električne osobine reaktora su ispitane derivativnim sondama. Merenjima derivativnim sondama je pokazano da strujni signal ima vrlo nepravilan oblik zbog izraženog drugog harmonika u frekventnom sastavu dok je naponski signal pravilnog sinusoidnog oblika. Takođe smo pokazali da RMS vrednosti struje i napona slabo zavise od rastojanja između napajane i uzemljene elektrode ali da se nešto veća efikasnost predaje snage plazmi postiže na većem rastojanju između elektroda. Primenom optičke emisije spektroskopije je ustanovljeno da tokom tretmana uzoraka od hidrofилnih materijala značajan efekat na plazmu ima vlaga koja je sadržana u uzorku ali i da uzorak utiče na protok toplotne energije od napajane ka uzemljenoj elektrodi. Takođe, pokazano je da otvaranjem komore radi postavljanja uzorka dolazi do adsorpcije molekula azota na njene zidove. Uključivanjem pražnjenja dolazi do desorpcije ali će njihova količina u plazmi vremenom opadati. Uniformnost pražnjenja je ispitana Langmirovom sondom i zaključeno je da je temperatura elektrona, za iste vrednosti snage i pritiska, uniformna u celoj ispitanoj zapremini ali da će plazmeni potencijal opadati sa udaljavanjem od centralne ose sistema.

U ovom reaktoru je rađen tretman pamučnih uzoraka azotnom plazmom sa ciljem nanošenja mikrokapsula na njihovu površinu. Kontrola uspešnosti tretmana je rađena poređenjem sa netretiranim uzorkom i uzorkom koji je na pritisku od 100 mTorr proveo deset minuta bez uključivanja plazme. Poređenjem K/S vrednosti, odnosno obojenosti uzoraka, za dve različite snage, od 50 i 100 W, je zaključeno da je u ovakvom reaktoru apsorpcija mikrokapsula veća ukoliko se

Plan-paralelno kapacitivno spregnuto pražnjenje

tretman radi na većem rastojanju između uzemljene i napajane elektrode. Istim testom je zaključeno da, u određenim granicama, povećanje snage pražnjenja tokom tretmana takođe dovodi do povećane apsorpcije. Međutim, na snazi od 200 W je došlo do oštećenja uzorka i apsorpcija je bila mala a sam uzorak je promenio boju, požuteo je. Analizom FTIR spektara tretiranih uzoraka je pokazano da tokom tretmana dolazi do stvaranja karbonilnih grupa na površni uzoraka dok se N-H grupa pojavljuje i nakon plazma tretmana ali i u uzorku koji nije bio tretiran plazmom, već je bio samo na niskom pritisku (u azotu). Uspešnija apsorpcija mikrokapsula na tretiranim uzorcima u odnosu na uzorke koji nisu izlagani plazmi je potvrđena i snimcima koji su napravljeni elektronskim mikroskopom SEM tipa.

4 MIKROTALASNO PRAŽNENJE

Reaktor za mikrotalasna pražnjenja u kome su dobijeni rezultati predstavljani u četvrtoj glavi ove disertacije nalazi se u Institutu Jožef Štefan u Ljubljani i merenja su urađena u saradnji sa Laboratorijom za tehnologije površina instituta Jožef Štefan. Merenja vezana za dijagnostiku plazme u reaktoru rađena su sa idejom da se detaljno opišu osobine plazme koje su od interesa za primenu u tretmanu tekstila, a zatim su urađeni i tretmani tekstilnih uzoraka. Sva merenja i tretmani predstavljani u ovoj glavi su urađeni u prostoru reaktora koji je daleko od same plazme, u kojem nema jona ali u kome je broj pobuđenih čestica i dalje velik, odnosno u takozvanom afterglow režimu (*eng* afterglow).

4.1 EKSPERIMENTALNA POSTAVKA

4.1.1 PLAZMA REAKTOR ZA MIKROTALASNA PRAŽNENJA

Šematski prikaz eksperimenta je dat na slici 4.1.1. Komora je cilindričnog oblika a njeni zidovi su napravljeni od borosilikatnog stakla. Ovaj materijal je izabran jer koeficijent rekombinacije za atome kiseonika i azota na njegovoj površini izuzetno mali. Gornja i donja strana komore su napravljene od nerđajućeg čelika. Unutrašnja strana reaktora je visoka 41 cm dok prečnik iznosi 30 cm.

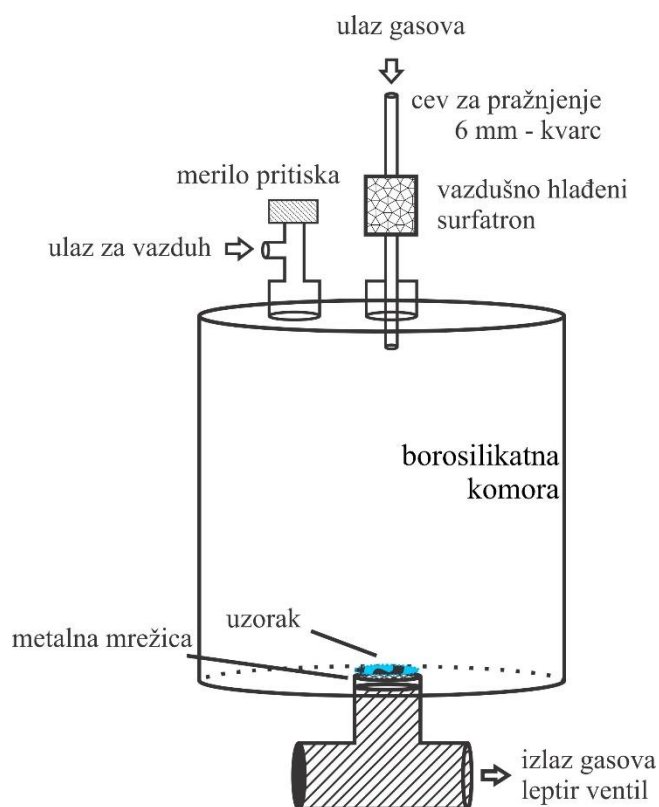

Slika 4.1.1 Šematski prikaz reaktora za mikrotalasna pražnjenja

Na sredini donje strane komore nalazi se centralno pozicioniran otvor kroz koji se ispumpavaju gasovi. Njegov dijametar iznosi 8 cm i pokriven je mrežicom od nerđajućeg čelika. Iako se mrežica nalazi u nivou dna komore, visina nosača na kome ona stoji iznosi 8 mm. Ispumpavanje gasova se obavlja mehaničkom pumpom preko ventila koji se elektronski kontroliše. Brzina pumpanja se može podešavati tako što se za propusnost ventila bira vrednost između 0 %, kada je on potpuno zatvoren, i 100 %, kada je on potpuno otvoren. U svim merenjima i tretmanima je ova vrednost bila podešena na 30 %. Gasovi u reaktor ulaze sa njegove gornje strane kroz cev od kvarca. Merilo pritiska se nalazi takođe na gornjoj strani komore a pritisak je, kao i u ostalim eksperimentima, kontrolisan protokom gasova. Ulaz za katalitičku sondu, koja je korišćena za merenje koncentracije atomskog kiseonika, se takođe nalazi na gornjoj strani reaktora i ona u komoru ulazi pod uglom. Ulazi za gasove i katalitičku sondu nisu centralno simetrični a njihove pozicije su šematski prikazane na horizontalnim poprečnim presecima komore na slici 4.1.2.

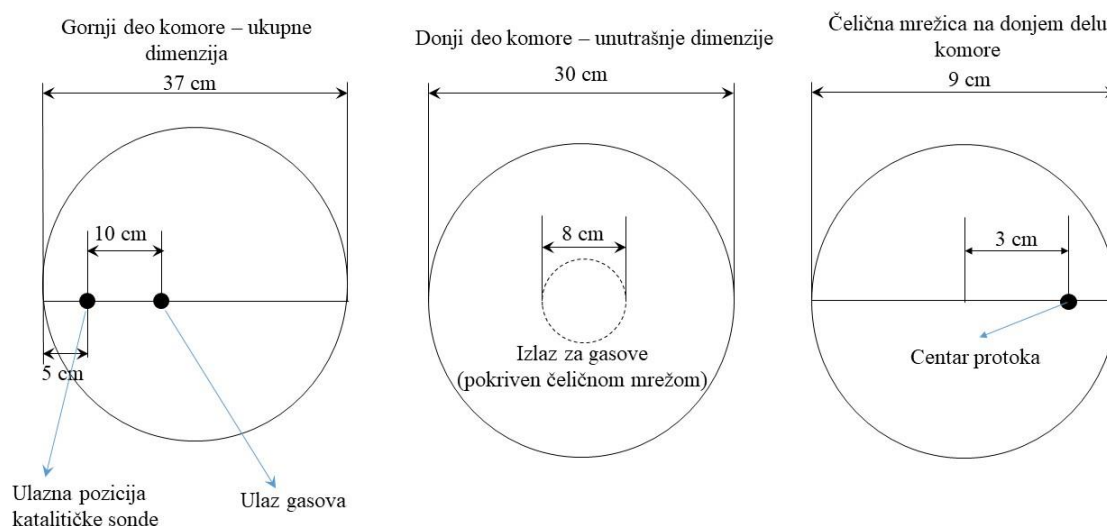

Slika 4.1.2 Šematski prikaz horizontalnog poprečnog preseka gornjeg dela komore (levo), donjeg dela komore (sredina) i pozicija ulaza za gasove na gornjem delu komore u odnosu na poziciju čelične mreže na izlazu za gasove na dnu komore (desno)

Za formiranje plazme u cevi kroz koju dolaze gasovi je korišćen GMP 03 mikrotalasni izvor snage koji radi na frekvenciji od 2450 MHz. Sva merenja su rađena na 300 W a predaja snage plazmi se obavlja vazdušno hlađenim surfatronom, koji se nalazi 6,5 cm iznad gornje ploče reaktora. Debljina ploče iznosi 2 cm.

Cevi za uvod gasova

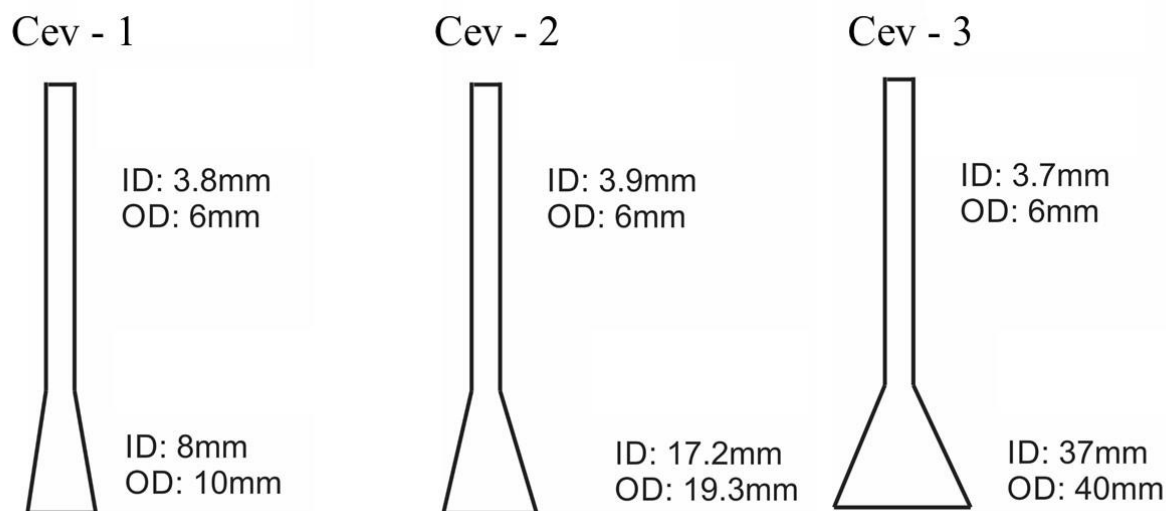

Slika 4.1.3 Tri cevi koje su korišćene za uvod gasova sa naznačenim unutrašnjim (ID) i spoljašnjim (OD) prečnikom

U našim eksperimentima su korišćene tri cevi za uvod gasova. Pravljene su tako da budu identičnih dužina ali da se na njihovim krajevima nalaze konusi različitih dimenzija. Veličine spoljašnjeg prečnika, u najširem delu cevi, se kreću između 10 i 40 mm a detaljne dimenzije za svaku cev su predstavljene na slici 4.1.3.

4.1.2 KATALITIČKA SONDA

Katalitička sonda je jedna od najjednostavnijih dijagnostičkih metoda za merenje koncentracije atomskog kiseonika. Iako postoje i posebne, fiber optičke, izvedbe [207] ona se najčešće konstruiše kao termopar na čijem se toplijem kraju nalazi vrh sonde [208], [209] kao što je prikazano na slici 4.1.4. Materijal vrha sonde mora da bude takav da omogućava rekombinaciju atomskog kiseonika na njegovoj površini. Najčešće se koristi nikl [207], [208] ali su upotrebi i sonde od gvožđa [210] i drugih materijala.

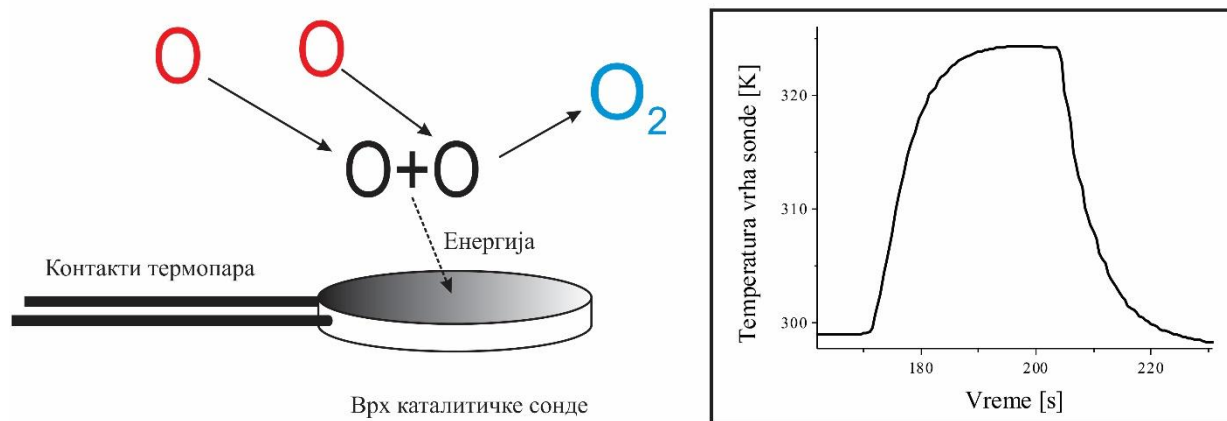

Slika 4.1.4 Princip rada katalitičke sonde (levo) i promena temperature na njoj tokom merenja (desno)

Princip rada katalitičke sonde se zasniva na rekombinaciji atoma kiseonika na površini. U tom procesu će nastati molekuli kiseonika a razlika energije će se predati površini u vidu toplote. Na desnoj strani slike 4.1.4 je prikazana promena temperature katalitičke sonde tokom vremena. Sa dolaskom sve većeg broja atoma do njene površine, temperatura će u početku da raste relativno brzo. Sonda će, međutim, određenu količinu toplote da gubi predajući je električnim kontaktima i gasu u komori dok će se jedan njen deo izgubiti i kroz zračenje. Temperatura će prestati da se menja kada se izjednače toplotni gubici sa energijom koja se sondi predaje zbog rekombinacija na njenoj površini. Tada se pražnjenje gasi a iz brzine opadanja temperature može da se dobije ukupna „snaga“ hlađenja. S obzirom na to da je pre isključenja plazme ona bila identična sa snagom grejanja, iz tog podatka može da se proceni broj rekombinacija na sondi u jedinici vremena odnosno koncentracija atomskog kiseonika u toj tački prostora.

Ukoliko se merenja ovakvim sondama obavljaju u centralnom delu plazme, njima se mogu dobiti rezultati koji će u izvesnoj meri da precene koncentraciju atoma kiseonika. Ovo se događa zato što će grejanju sonde doprinositi i apsorpcija fotona iz aktivne zone pražnjenja ali i joni koji dolaze na njenu površinu [211]. U našim eksperimentima prikazanim u ovom poglavlju merenja su rađena u oblasti pražnjenja u kojima ova dva mehanizma grejanja imaju zanemarljiv doprinos.

Jedan par atoma će prilikom procesa rekombinacije sonde da preda energiju od 5,12 eV [209]. Fluks neutralnih čestica koje se u gasu kreću ka određenoj površini može da se dobije iz formule:

$$j = \frac{1}{4} nv. \quad (4.1)$$

Ovde je sa n obeležena koncentracija čestica, u našem slučaju O atoma, a sa v njihova srednja termalna brzina koja ima poznati oblik:

$$v = \sqrt{\frac{8kT}{\pi m}}. \quad (4.2)$$

Ukupna snaga koja se sondi predaje se dobija tako što se fluks čestica pomnoži sa površinom sonde S , kako bi se dobio broj atoma koji do nje dolazi. Dobijenu vrednost treba pomnožiti sa koeficijentom rekombinacije γ , koji zavisi od upotrebljenog materijala, i sa energijom koja se predaje jednom rekombinacijom W_D . Dobijena snaga grejanja sonde usled rekombinacije atoma na kraju iznosi:

$$P_g = j\gamma S \frac{W_D}{2} = \frac{1}{8} nvSW_a. \quad (4.3)$$

Mikrotalasno pražnjenje

Faktor $\frac{1}{2}$ u prethodnoj jednačini se pojavljuje zato što se molekuli kiseonika sastoje od dva atoma.

Kao što je rečeno, postoji više mehanizama hlađenja sonde. Iako bi bilo poželjno da se zna precizan doprinos svakog njih to, međutim, nije neophodno. Svaki od njih će pojedinačno da doprinese hlađenju sonde ali ukupna promena temperature, odnosno dT/dt , zapravo predstavlja njihov kumulativan efekat. Ukoliko se izmeri brzina promene temperature, može da se izračuna i ukupna energija koja sondu napušta u jedinici vremena odnosno ukupna snaga hlađenja. Ovu veličinu možemo da predstavimo kao:

$$P_h = Mc_p \frac{dT}{dt}, \quad (4.4)$$

gde je M masa sonde a c_p njen specifični toplotni kapacitet.

Konačno, koncentraciju atoma kiseonika možemo da izračunamo tako što se izjednače jednačine za snagu grejanja i hlađenja odakle se dobija:

$$n = \frac{8Mc_p}{\gamma v S W_D} \frac{dT}{dt}. \quad (4.5)$$

U našim merenjima je korišćena sonda od kobalta, pravougaonog oblika. Dužine je 4,8 mm i širine 1,75 mm dok joj debljina iznosi svega 30 μm .

Merenja su obavljena na tri pozicije koje su ilustrovane na slici 4.1.5. Izbor mernih pozicija je bio ograničen konstrukcijom komore jer je sondu moguće pomerati samo po jednoj dimenziji a u komoru ulazi pod uglom. Lokacija koju smo nazvali donja pozicija je odabrana tako da se vrh sonde nalazi što je bliže moguće samom dnu komore a da se pri tom ne ugrozi telo sonde koje je napravljeno od kvarcnog stakla. Lokaciju koju smo odabrali tako da sonda bude najbliža centralnom toku gasova smo nazvali središnja pozicija. Poslednja merna tačka nalazi se u nivou najnižeg dela konusa cevi kroz koju ulaze gasovi i nju smo nazvali gornja pozicija.

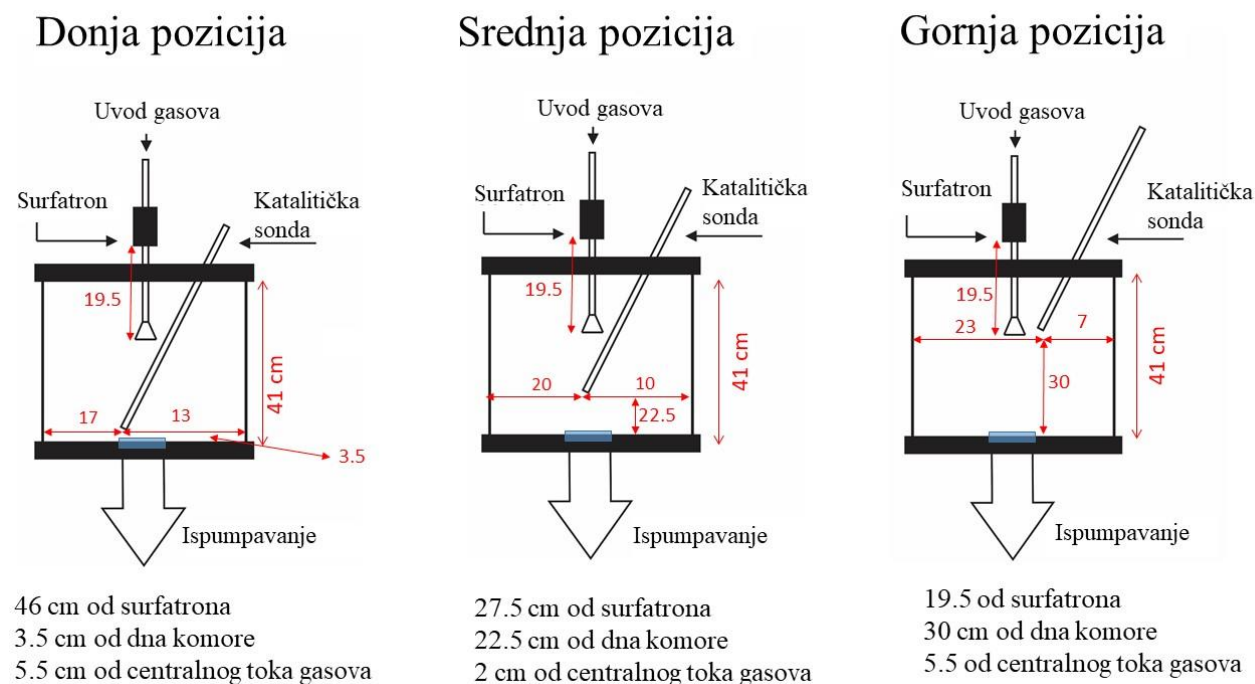

Slika 4.1.5 Prostorne pozicije katalitičke sonde tokom merenja sa rastojanjima. Donja – najbliža dnu komore, Središnja – najbliža centralnom toku gasova, Gornja – u nivou cevi za uvod gasova.

4.2 REZULTATI MERENJA I DISKUSIJA

4.2.1 KATALITIČKA SONDA

S obzirom na to da je kontrola pritiska u komori vršena jedino kontrolom protoka radnog gasa, bilo je potrebno da se proveriti da li će za sve tri cevi koje su korišćene isti protok odgovarati istom pritisku. Rezultat ovog testa je prikazan na slici 4.2.1 na kojoj su upotrebljene cevi obeležene, redom od one sa najužim konusom do one sa najširim, , kao na slici 4.1.3 crnom, crvenom i zelenom bojom a pozicije vrha sonde, počev najniže, krugom, kvadratom i trouglom.. U najvećem delu opsega protoka i pritisaka su ostvarene skoro identične vrednosti. Određene razlike postoje samo na najmanjim vrednostima i tada je za postizanje identičnog pritiska bio potreban najmanji protok za cev sa najširim konusom na kraju, dok je najveći protok bio potreban za cev sa najužim konusom na svom kraju. Ovo je i očekivano jer se pritisak meri na gornjoj strani komore. Uska cev će gasove da usmerava praktično direktno ka otvoru za ispušavanje dok će kod cevi sa širokim konusom na kraju gasovi nešto lakše ispunjavati celu zapreminu reaktora. Ipak, kako povećanjem protoka ove razlike vrlo brzo postaju zanemarljive, a nisu velike čak ni na malim pritiscima, možemo da kažemo da će, nevezano za to koja je cev bila upotrebljena i protok, pri istom pritisku, u komoru ulaziti skoro isti broj atoma.

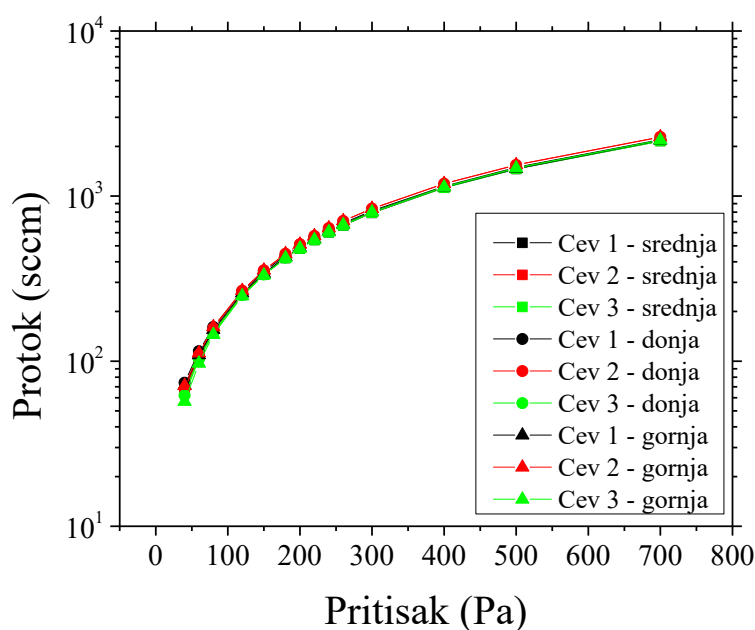

Slika 4.2.1 Protoci kojima su ostvareni željeni pritisci za sve tri različite cevi: Cev-1 (crna boja), Cev-2 (crvena) i Cev-3 (zeleno) i sve tri merne pozicije katalitičke sonde: srednja (kvadrat), donja (krug) i gornja (trougao).

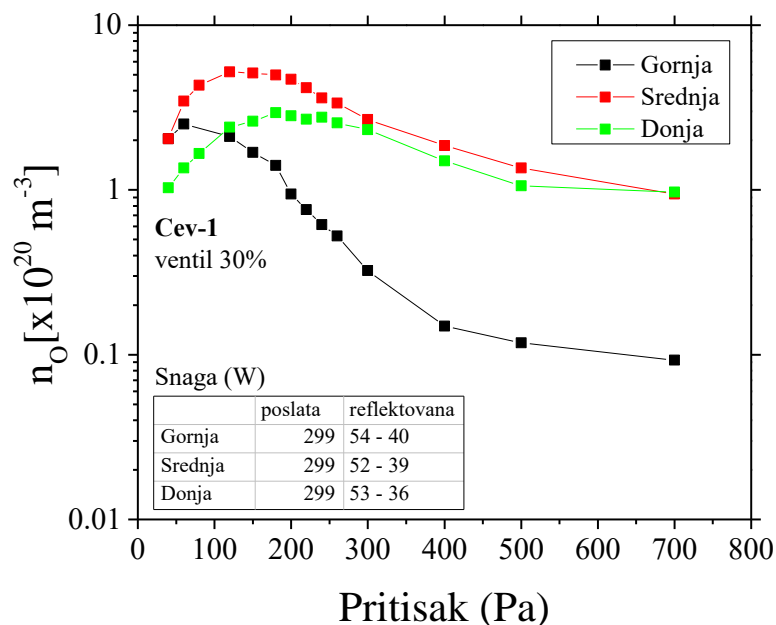

Slika 4.2.2 Koncentracija atomskog kiseonika izmerena korišćenjem cevi sa najužim konusom na kraju (Cev-1) na sve tri merne pozicije i na različitim pritiscima, sa naznačenom poslatom i reflektovanom snagom surfatrona tokom merenja.

Koncentracija atomskog kiseonika na sve tri različite pozicije, koja je izmerena kada je korišćena Cev-1, u zavisnosti od pritiska je prikazana na slici 4.2.2. Da podsetimo, u pitanju je najuža cev koja ima unutrašnji prečnik konusa, na najširem delu, svega 8 mm. Najveća koncentracija, od oko $5 \times 10^{20} \text{ m}^{-3}$ je zabeležena tokom merenja na srednjoj poziciji. S obzirom da se ona nalazi svega 2 cm od centralnog protoka gasa, ovo je bio i očekivan rezultat. Sa druge strane, na srednjoj i donjoj poziciji su, na malim pritiscima, izmerene iste koncentracije O atoma, od oko $3 \times 10^{20} \text{ m}^{-3}$. Na najmanjem pritisku je srednji slobodni put čestica veliki i to su uslovi u kojima će atomi, difuzijom, najlakše da dođu do sonde na gornjoj poziciji. Maksimum koncentracije, na toj poziciji, je upravo i dobijen na svega 60 Pa. Povećanjem pritiska se srednji slobodni put čestica značajno smanjuje pa će ova pozicija postati praktično nedostupna za atome kiseonika, odnosno njihova koncentracija će biti vrlo mala, što pokazuju i izmerene vrednosti. Na donjoj poziciji će, na malim pritiscima, koncentracije biti male zbog gubitka atomskog kiseonika usled rekombinacije na donjoj ploči reaktora. Povećanjem pritiska i protoka, ovi gubici postaju sve manje značajni što praktično dovodi do izjednačavanja izmerenih koncentracija na donjoj i srednjoj poziciji.

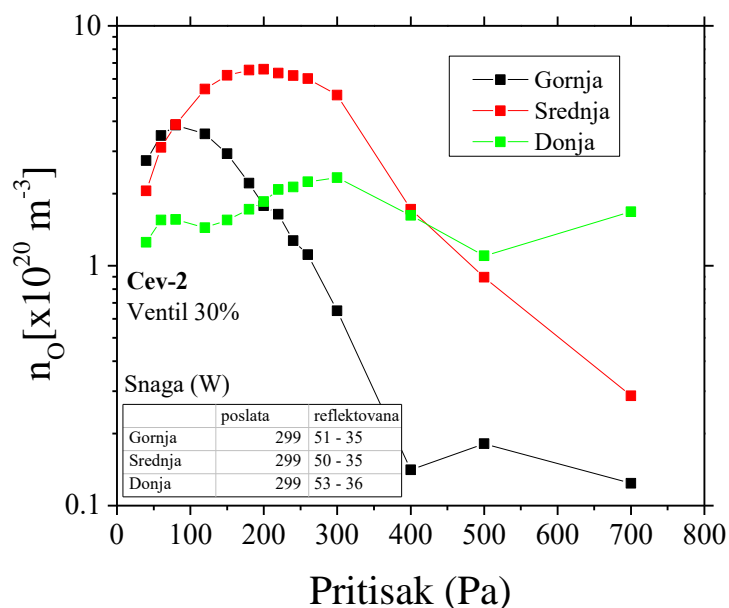

Slika 4.2.3 Koncentracija atomskog kiseonika izmerena korišćenjem cevi sa prečnikom konusa na najširem delu od 17,2 mm (Cev-2) na sve tri merne pozicije i na različitim pritiscima, sa naznačenom poslatom i reflektovanom snagom surfatrona tokom merenja.

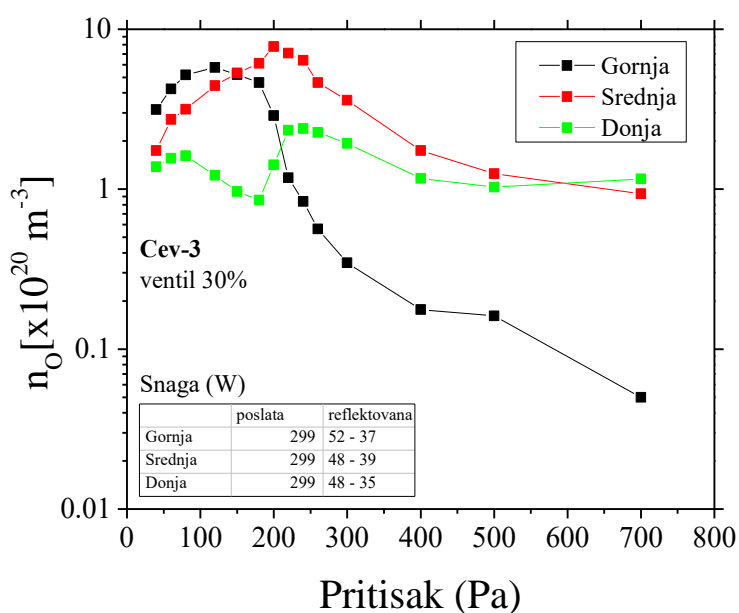

Slika 4.2.4 Koncentracija atomskog kiseonika izmerena korišćenjem cevi sa najširim konusom na kraju (Cev-3) na sve tri merne pozicije i na različitim pritiscima, sa naznačenom poslatom i reflektovanom snagom surfatrona tokom merenja.

Kada su korišćene cevi 2 (slika 4.2.3) i 3 (4.2.4) čiji su najširi delovi konusa, respektivno, 17,2 i 37 mm, maksimumi koncentracija su bili nešto viši za gornju i srednju poziciju. Takođe, na obe pozicije su maksimumi postignuti na višim pritiscima nego kada je korišćena cev najužeg konusa. Ovi rezultati se slaži sa tvrdnjom da do gornje pozicije atomi kiseonika mogu da dođu samo

difuzijom. Širenjem konusa na kraju cevi za uvod gasova će radijalna difuzija da bude veća pa će i atomi lakše da dođu do nje, odnosno biće im izmerena veća koncentracija. Sa druge strane, rezultati koji su dobijeni na srednjoj poziciji mogu da se objasne samo ukoliko pretpostavimo da je protok u tom delu reaktora definisan samo najužim delom cevi i da širina konusa tu ne igra veliku ulogu.

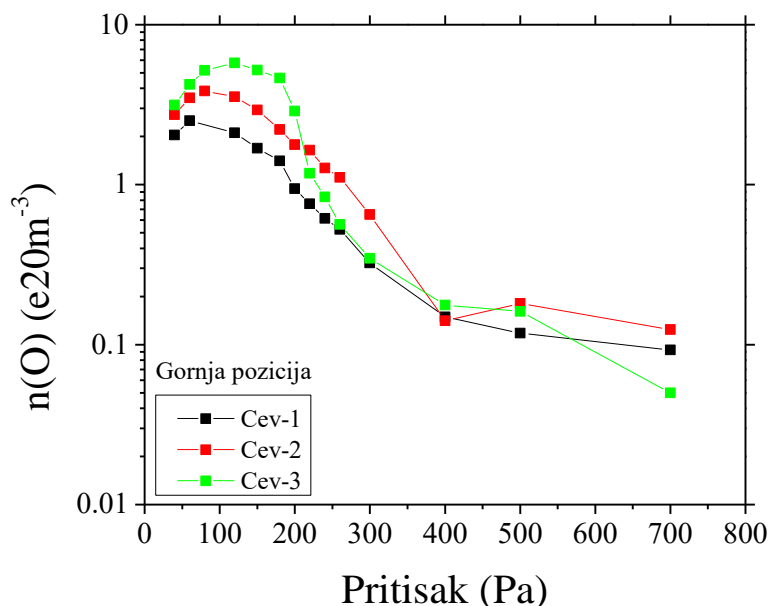

Slika 4.2.5 Koncentracija atomskog kiseonika izmerena na gornjoj poziciji sonde korišćenjem cevi sa tri različita konusa: Cev-1 (crna), Cev-2 (crvena) i Cev-3 (zeleno)

Malo drugačije poređenje može da se dobije ukoliko se pogledaju koncentracije atomskog kiseonika koje su dobijene na istoj mernoj poziciji sa cevima različitih konusa. Na slici 4.2.5 se nalazi poređenje za gornju poziciju. Odavde se još jasnije vidi da se širenjem otvora konusa na cevi olakšava difuzija O atoma ka gornjem delu reaktora. Na nižim pritiscima, sa povećanjem prečnika konusa, koncentracija će da bude veća. Takođe, do maksimuma koncentracije dolazi na nešto većim pritiscima ukoliko je korišćena cev sa konusom većeg poluprečnika. Na pritiscima preko 300 Pa pritisak postaje dovoljno veliki da O atomi sve teže mogu da dođu gornje pozicije, što se vidi i kroz pad izmerene koncentracije i kroz činjenicu da na pritiscima višim od 400 Pa koncentracija više ne zavisi od širine konusa i da je praktično ista za sve tri cevi.

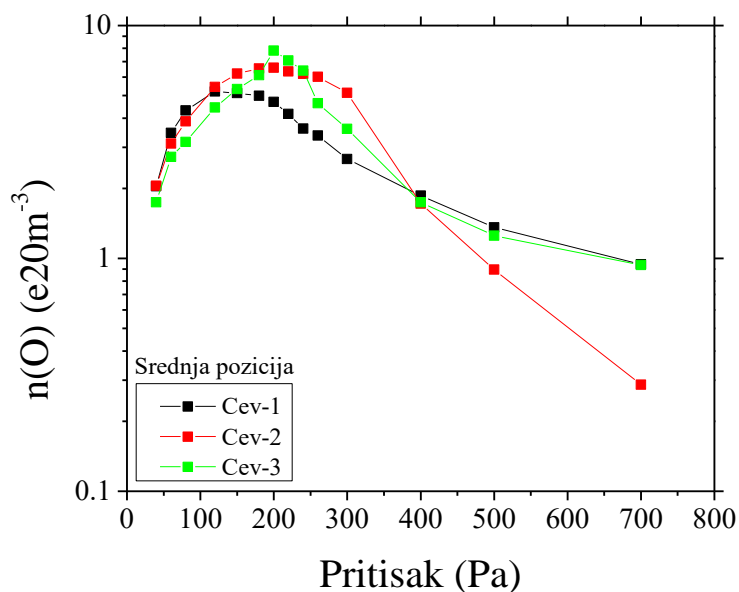

Slika 4.2.6 Koncentracija atomskog kiseonika izmerena na srednjoj poziciji sonde korišćenjem cevi sa tri različita konusa: Cev-1 (crna), Cev-2 (crvena) i Cev-3 (zeleno)

Koncentracije kiseonika koje su dobijene na srednjoj poziciji upotrebom različitih cevi, upoređene su na slici 4.2.6. Maksimumi koncentracija su, u poređenju sa gornjom pozicijom, nešto veći ali su i postignuti na većim pritiscima. Podsetimo, ovo je pozicija koja je najbliža oblasti sa intenzivnim protokom gasova. Iako se koncentracije koje su dobijene upotrebom različitih cevi ne razlikuju značajno, može da se primeti da će vrednosti maksimuma biti nešto veće ukoliko je korišćena cev sa konusom većeg prečnika. Na ovoj udaljenosti od surfatrona širina konusa očigledno ne utiče značajno na broj O atoma ali je i dno komore dovoljno daleko da se još uvek ne vide ni efekti blizine otvora za ispušavanje gasova.

Situacija je nešto specifičnija kada se uporede koncentracije koje su sa cevima različitih konusa izmerene na donjoj poziciji, slika 4.2.7, neposredno iznad otvora za ispušavanje gasova. Koncentracije su niže u poređenju sa onim dobijenim na prethodne dve pozicije. Međutim, najupečatljivija karakteristika zavisnosti koncentracije od pritiska je pojava dvostrukog maksimuma i jednog lokalnog minimuma. Ovaj karakterističan pad koncentracije je vidljiv na sve tri upotrebene cevi. Najizraženiji je na cevi sa najširim konusom na kraju dok je najmanje primetan na cevi sa najužim konusom. Razlozi za pojavu ovog lokalnog minimuma mogu da leže u načinu na koji protok zavisi od srednjeg slobodnog puta čestica koji, sa druge strane, takođe zavisi od pritiska. S obzirom da se pritisak kontroliše protokom a da je brzina ispušavanja konstantna, sa povećanjem protoka dolazi do akumulacije atoma u donjim delovima reaktora. Dodatno, metalna ploča na donjoj strani komore, kao treće telo, postaje mesto na kome dolazi do spajanja atoma u molekule, odnosno ona se praktično ponaša kao ponor za atome. Do lokalnog minimuma može da dođe i zbog toga što povećanje koncentracije atoma u donjim delovima komore i brzina njihovog nestajanja na donjoj ploči ne zavise na isti način od pritiska/protoka. Odnosno, do lokalnog minimuma može da dođe na onim uslovima na kojima poniranje atoma smanjuje njihov broj brže nego što on raste zbog nagomilavanja usled protoka. Podsetimo, otvor ventila je za sve uslove merenja bio fiksiran na 30 %.

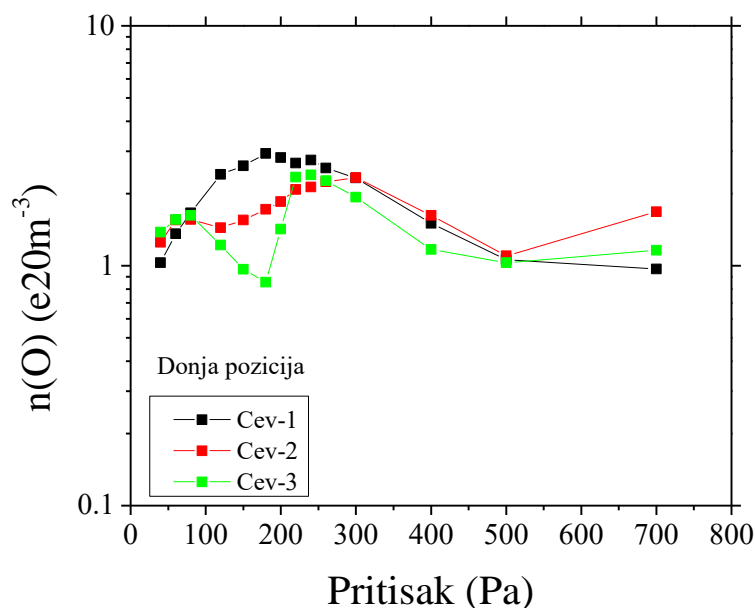

Slika 4.2.7 Koncentracija atomskog kiseonika izmerena na donjoj poziciji sonde korišćenjem cevi sa tri različita konusa: Cev-1 (crna), Cev-2 (crvena) i Cev-3 (zeleno)

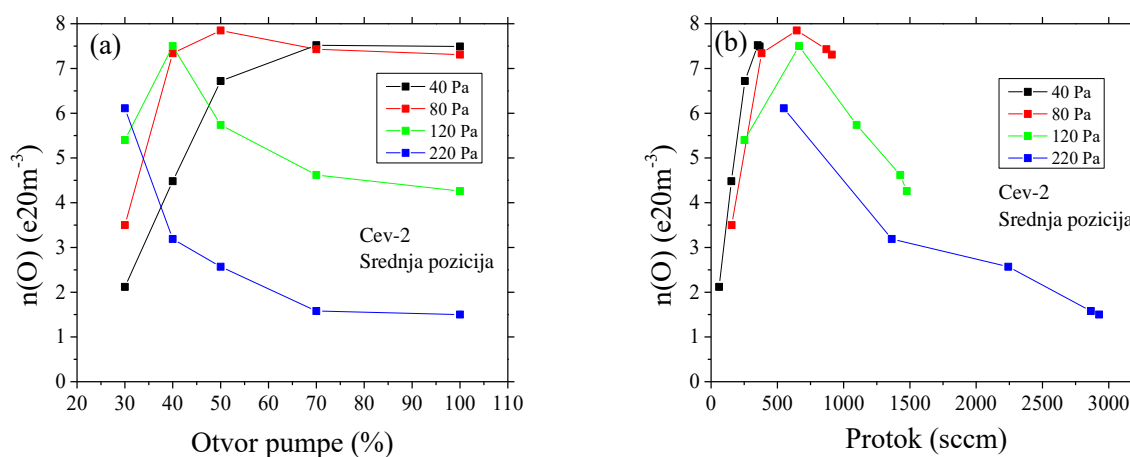

Slika 4.2.8 Koncentracija atomskog kiseonika dobijena na srednjoj poziciji korišćenjem cevi-2 za 4 različita fiksna pritiska u zavisnosti od a) otvora pumpe i b) protoka O₂.

Iz prethodnih rezultata se nameće pitanje važnosti protoka gasa kao krucijalnog parametra za kontrolu koncentracije atomskog kiseonika. Na slici 4.2.8 je prikazana zavisnost koncentracije kao funkcija procenta otvorenosti ventila pumpe (4.2.8 a) i kao funkcija protoka gasa (4.2.8 b)) za četiri različita pritiska, pri čemu su isti rezultati predstavljeni na dva različita načina. Vidimo da za pritiske koji su manji od 100 Pa otvaranje ventila dovodi direktno do povećanja koncentracije atoma. Sa druge strane, na visokim pritiscima povećanje otvorenosti ventila dovodi do pada koncentracije O atoma. Iako ovo može da izgleda neočekivano, ovi rezultati se u najvećoj meri slažu sa razmatranjem uticaja smanjenja srednjeg slobodnog puta na mogućnost čestica da dopru do svih delova reaktora. Ovo je jasnije vidljivo na slici 4.2.8 b). Za male pritiske su ostvareni maksimumi protoka od 250 sccm (40 Pa) i 1000 sccm (80 Pa). Daljim povećanjem protoka nije mogao da se ostvari stabilan balans između snabdevanja reaktora gasom i brzine pumpanja kako bi pritisak ostao na željenoj vrednosti.

Već na pritisku od 80 Pa može da se vidi da, povećanjem protoka, dolazi do pojave maksimuma koncentracije, posle kojeg dolazi do opadanja. Ovakav maksimum je vidljiv i na pritisku od 120 Pa. Na pritisku od 220 Pa on nije vidljiv jer dodatnim spuštanjem protoka nije bilo moguće održati pritisak.

4.2.2 ZAKLJUČAK

U ovoj glavi smo predstavili rezultate merenja koncentracije atomskog kiseonika katalitičkom sondom u oblasti pražnjenja koja je daleko od izvora jona ali u kojoj postoji veliki broj aktivnih vrsta. Za uvod gasova su korišćene cevi koje na svojim krajevima imaju konuse različitih dimenzija, što neminovno utiče na način kako se gas kreće kroz reaktor. Koncentracije su merene na tri karakteristične pozicije sonde: u visini cevi za uvod gasova, najbliže centru toka gasova i najbliže otvoru za ispušavanje. Na većini mernih uslova (širina konusa, pozicija sonde) sa povećanjem pritiska će koncentracija da raste do određenog maksimuma nakon čega opada zbog skraćivanja srednjeg slobodnog puta atoma koji sve teže mogu da dođu do površine sonde. Međutim, na najnižoj poziciji se, za sva tri različita konusa, pojavljuje izražen lokalni minimum na određenim vrednostima protoka/pritiska. Naša pretpostavka je da do toga dolazi jer u blizini najniže pozicije sonde, na donjoj ploči reaktora, u tim uslovima dolazi do intenzivne rekombinacije atoma kiseonika u molekule. Povećanjem protoka će koncentracija nastaviti da raste. Ovaj fenomen je najizraženiji kada je korišćena cev sa najširim konusom na kraju. Korišćenjem užih konusa se gasovi usmeravaju praktično direktno ka otvoru za ispušavanje pa efekat blizine donje ploče dolazi manje do izražaja. Za ostale dve pozicije koncentracija je manja kada je korišćena cev užeg konusa jer su atomi, sužavanjem konusa, sve više skoncentrisani u centralnom toku gasova i zbog delovanja pumpe teže mogu da dođu u sve delove reaktora. Za sve tri različite cevi je koncentracija atoma bila najveća na srednjoj poziciji koja je najbliža centralnom protoku gasa. Iz priloženih rezultata može da se zaključi da je, u ovakvom tipu reaktora, koncentracija atomskog kiseonika gotovo jednoznačno određena protokom gasa.

4.3 PRIMENE MIKROTALASNOG PRAŽNJENJA U TRETMANU TEKSTILA

U ovom poglavlju ćemo pokazati da se i režim pražnjenja koji je korišćen u našim eksperimentima, daleko od samog izvora jonizacije (afterglow), može uspešno koristiti za tretman tekstila sa ciljem nanošenja mikrokapsula. Glavni motiv je bio da se napravi tkanina koja bi na prisustvo ultraljubičastog zračenja reagovala promenom boje. Na taj način bi se praktično dobio savitljiv UV detektor. U tu svrhu se najčešće koriste već postojeći fotosenzitivni materijali koji na prisustvo UV zračenja zaista i reaguju tako što im se boja promeni. Kada se izvor zračenja ukloni, oni se vraćaju u početno stanje. Međutim, takvi materijali i boje brzo degradiraju ukoliko su izloženi kiseoniku, ekstremnim pH vrednostima, jakom svetlu ili previsokoj temperaturi. Upravo zbog toga ih je poželjno koristiti u obliku mikrokapsula [212], [213]. Obećavajući materijal, koji bi mogao da se koristi kao nosač, je PET tkanina. Otporna je na različite hemikalije, vremenske uslove i UV zračenje a odlikuje je i velika zatezna čvrstoća [214]. Njena negativna osobina je izrazita hidrofobnost, što znači da je takav tekstil jako teško obojiti ili naneti na njega mikrokapsule. Taj problem je rešiv upotrebom neravnotežnih plazmi ali uspešnost rešenja zavisi u velikoj meri i od odabira gasova u kojima će tretman tekstila biti obavljen. Poznato je da se tretmanom u kiseoničnoj plazmi utiče na povećanje hidrofilitnosti PET tkanine [215], [216]. Sa druge strane, da bi se boje uspešno nanele potrebno je da na površini tekstila postoje funkcionalne grupe koje sadrže amine, što se može postići tretmanom u NH_3 pražnjenjima [217], [218]. Zbog toga smo se u našem pristupu odlučili da se tretman obavlja u dve etape. Uzorci će prvo biti izloženi kiseoničnoj plazmi kako bi se njihova

površina aktivirala i fizički tretirala za bojenje a onda će biti dodatno tretirani u NH₃ pražnjenju kako bi se kroz hemijske reakcije pripremili za nanošenje boja koje u sebi sadrže mikrokapsule.

4.3.1 EKSPERIMENTALNA POSTAVKA

Za vakuumiranje sistema, održavanje pritiska i napajanje eksperimenta je korišćena ista oprema koja je opisana u glavi 4.1. Uzorci se pre tretmana postavljaju preko mrežice na otvoru za izlaz gasova iz komore. Reaktor se zatim vakuumira do minimalnog pritiska koji je moguće postići, što je u našim eksperimentima iznosilo 3 Pa. Tokom svih tretmana je pritisak, upuštanjem gasova, održavan na vrednosti od 40 Pa. Kako bi se to postiglo, kiseonik čistoće 99,99 % je bilo potrebno upuštati sa protokom od 220 sccm. Protok amonijaka, iste čistoće, nismo bili u mogućnosti da direktno merimo ali ga je pomoću preciznog igličastog ventila bilo moguće podesiti tako da pritisak ostane fiksiran na vrednosti od 40 Pa. Kada su tretmani rađeni i u kiseoniku i amonijaku, nakon tretmana kiseonikom je dotok zatvaran dok pritisak ne padne 3 Pa pa je zatim upuštan amonijak. Primenjena, nominalna, snaga pražnjenja iznosila je 150 W za oba radna gasa.

Pored aktivnih kiseonikovih vrsta, uzorci su na ovaj način, kada je u komori bio amonijak, bili izloženi i NH_x radikalima kao i atomskom vodoniku u svom osnovnom stanju.

S obzirom na to da mikrokapsule ne mogu direktno da se vežu na PET tkaninu, napravljen je rastvor koji u sebi sadrži 50 g/l UV osetljivih mikrokapsula ali i 50 g/l posebnog veziva. Uzorci se potapaju u ovaj rastvor a nakon vađenja se prvo ocede pa se zatim suše u dve etape. U prvom koraku se 5 min suše na temperaturi od 100 °C dok se u sledećem ostavljaju 3 min na temperaturi od 150 °C. Apsorbovana masa mikrokapsula se računa po sledećoj formuli:

$$\Delta m(\%) = \frac{m_2 - m_1}{m_1} * 100. \quad (4.6)$$

Ovde je sa m_1 obeležena masa uzorka pre nanošenja mikrokapsula a sa m_2 nakon opisanog procesa.

Za analizu površine uzoraka je korišćena FTIR (*eng* Fourier Transform Infrared Spectroscopy) metoda. Spektri su dobijeni korišćenjem Bruker IFS 66/S spektrometra rezolucije 4 cm⁻¹. Tokom analize uzorci su bili pripijeni na cilindar od germanijuma.

Za analizu sastava površine uzorka je korišćena XPS metoda (*eng* X-ray Photoelectron Spectroscopy). U komori uređaja (TFA Physical Electronics XPS) postiže se vakuum od 6*10⁻⁸ Pa. Uzorci su pobuđivani monohromatskim snopom (Al K_{α1,2}) energije 1486,6 eV dok su foto-elektroni detektovani polusfernim analizatorom pod uglom od 45° u odnosu na površinu uzorka.

Hidrofilnost uzoraka je ispitivana standardizovanim AATCC 39-1980 testom (*eng* American Association of Textile Chemists and Colorists). On podrazumeva da se kapljica vode pažljivo nanosi na površinu uzorka a meri se vreme koje protekne između trenutka u kome kapljica dodirne tkaninu do trenutka u kome je ona potpuno apsorbovana uzorkom. Uzorak je hidrofilniji ukoliko je vreme apsorpcije kraće.

Za proveru osetljivosti tretiranih uzoraka na UV zračenje korišćen je model spektrofotometra koji meri refleksiju SF 600 PLUS-CT (Datacolor, Švajcarska). Njihov odziv je meren kao promena boje posle izlaganja ultraljubičastoj svetlosti za šta su korišćene dve Philips UVA lampe od 18 W. Osvetljavanje je trajalo 1 min sa udaljenosti od 15 cm. Za ocenu boje je korišćen CIELAB sistem koji je dizajniran tako da približno odgovara načinu na koji ljudi percipiraju boje. Tako opisane boje imaju tri koordinate. Svetlina se obično obeležava oznakom L* a vrednost 0 označava crnu boju dok vrednost 100 označava difuzno belu. Druge dve koordinate se označavaju sa a* i b* i njima se opisuje pozicija boje između crvene i zelene (a*) i između žute i plave (b*). Ukupna promena boje uzoraka ΔE*_{ab} pre i posle osvetljavanja UV lampom se dobija po formuli:

Mikrotalasno pražnjenje

$$\Delta E_{ab}^* = \sqrt{\Delta E^{*2} + \Delta a^{*2} + \Delta b^{*2}}. \quad (4.7)$$

Tokom ovih merenja, uzorci su presavijani po dva puta da bi se dobio četverostruki sloj.

Jačina boje osvetljenih uzoraka je dobijena preko reflektanse, R, korišćenjem standardne formule za dobijanje K/S vrednosti:

$$\frac{K}{S} = \frac{(1-R)^2}{2R}. \quad (4.8)$$

Ovde je sa K obeležen koeficijent apsorpcije a sa S koeficijent rasejanja. Ukoliko indeksom 1 označimo netretirane uzorke a sa indeksom 2 tretirane, promena u jačini boje može da se dobije kao:

$$I(\%) = \frac{K/S_2 - K/S_1}{K/S_1}. \quad (4.9)$$

Vazдушna permeabilnost uzoraka (mm/s) je testirana po ISO 9237:1999 standardu korišćenjem AirTronic 3240A (MESDAN) testera uz pad pritiska od 100 Pa.

4.3.2 REZULTATI TRETMANA

Uzorci su tretirani kiseoničnom plazmom u trajanju od 100 ili 200 s i zatim NH₃ plazmom u trajanju 3, 81 i 243 s. Radi provere efekata koje daje kombinovani tretman, urađeni su i posebni tretmani samo u kiseoničnoj i samo u NH₃ plazmi.

Tabela 4.3.1 Površinski sastav netretiranih i tretiranih uzoraka dobijen XPS analizom površine. Rezultati su izraženi u % ukupnog atomskog sastava.

Tretman	C	N	O	O/C	N/C
Netretiran	76,3	0	23,7	0,31	-
100s O ₂	62,8	0	37,2	0,59	-
100s NH ₃	73,6	0,8	25,6	0,36	0,01
100s O ₂ + 3sNH ₃	61,1	2,5	36,4	0,60	0,04
100s O ₂ + 81s NH ₃	60,4	3,4	36,4	0,60	0,05
100s O ₂ +243s NH ₃	59,2	4,6	36,3	0,61	0,08
200s O ₂ +243s NH ₃	58,7	5,0	36,3	0,62	0,09

U tabeli 4.3.1 je prikazan atomski sastav površine uzoraka dobijen XPS metodom. Kao što je i očekivano, u netretiranim uzorcima se nalazi velika količina ugljenika a odnos kiseonika prema ugljeniku iznosi 0,31. Nakon tretmana samo u NH₃ plazmi ne dolazi do značajne promene u količini ugljenika ali je došlo do blagog povećanja količine kiseonika. Razlog za ovaj čudan rezultat može da leži ili u eksperimentalnoj grešci ili u činjenici da raspoloživom opremom nije bilo moguće postići visok vakuum već je pritisak spuštano do minimalne vrednosti od 3 Pa. Veliki deo rezidualnih gasova čini voda, koja izlaganjem mikrotalasnoj plazmi stvara OH radikale koji mogu da se veži za površinu uzorka. Ono što je posebno važno primetiti je da NH₃ tretman, bez kiseonične pripreme uzorka, ne dovodi do značajne adsorpcije azota na površini, svega 0,8 %. Tretmanom samo u kiseoničnoj plazmi dolazi do pada u površinskoj koncentraciji ugljenika ali do porasta u koncentraciji kiseonika tako da se dobija O/C odnos od 0,59. Korišćenje prvo kiseonične pa zatim NH₃ plazme dovodi do značajne adsorpcije azota na površinu uzorka. Nakon što je uzorak proveo samo tri sekunde u plazmi amonijaka, količina azota na njegovoj površini iznosi 2,5 %. Produžavanjem tretmana je u našim eksperimentima postignut maksimum od 5 % azota. S obzirom na to da se produžavanjem tretmana smanjuje količina C atoma na površini a povećava količina N atoma, N/C odnos će da raste i moguće

je dobiti maksimum od 0,09. Zanimljivo je da se količina kiseonika na površini praktično ne menja sa promenom dužine tretmana i iznosi oko 36 % za sve uzorke, osim netretiranog i onog koji je tretiran samo u amonijaku.

S obzirom na to da XPS analizom ne može da se dobije podatak o vrstama funkcionalnih grupa, već samo o atomskom sastavu površine, urađena je dodatna FTIR analiza a rezultati su prikazani na slici 4.3.1. Pet najintenzivnijih apsorpcionih linija predstavljaju standardan spektar same PET tkanine. Apsorpcione linije malog intenziteta koje se pojavljuju između 2988 cm^{-1} i 2935 cm^{-1} pripadaju C-H sp³ vibracijama. Povećano prisustvo kiseonikovih grupa nakon tretmana može da se primeti u rastu intenziteta širenju linija na 1717 cm^{-1} (C=O), 1094 cm^{-1} (O=C-O-C) i 724 cm^{-1} (C=O). Linija koja se vidi na 3421 cm^{-1} pripada međumolekularnoj vezi između O-H i C=O grupe u poliesterskom lancu. Iako je taj pik mali, vidljiva je razlika između tretiranih i netretiranih uzoraka. U dobijenim spektrima ne postoje naznake prisustva amino grupa.

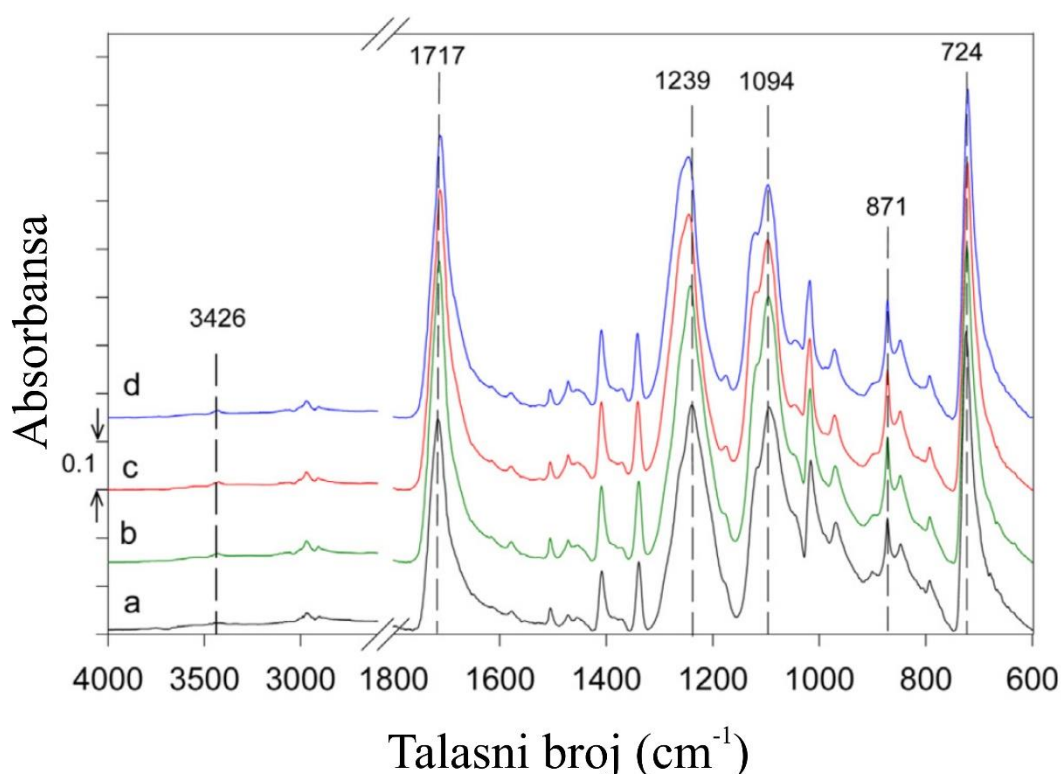

Slika 4.3.1 FTIR analiza tekstilnih uzoraka: a) netretirani uzorak, b) uzorak tretiran samo u kiseoničnoj plazmi, c) uzorak tretiran samo u plazmi amonijaka i d) uzorak tretiran prvo u kiseoničnoj a zatim u NH₃ plazmi.

Tabela 4.3.2 Test hidrofilitnosti uzoraka meren kao vreme potrebno za potpunu apsorpciju jedne kapljice vode

Tretman	Vreme apsorpcije (s)
Netretiran	54,5
100s O ₂	0,35
100s O ₂ + 100s NH ₃	0,95
100s NH ₃	28,13

Vremena apsorpcije kapljice vode, kao test hidrofilnosti, prikazana su za 4 karakteristična tretmana u tabeli 4.3.2. Poliesterska tkanina spada u red umereno hidrofobnih, za potpunu apsorpciju izmereno je vreme od 54,5 s. Nakon tretmana od 100 s samo u kiseoničnoj plazmi, hidrofilnost uzorka se značajno povećala pa je za apsorpciju jedne kapljice vode potrebno samo 0,35 s što je za dva reda veličine bolje u odnosu na netretiranu tkaninu. Ukoliko se uzorak izloži samo plazmi amonijaka, u trajanju od 100 s, hidrofilnost će biti bolja u odnosu na uzorak koji nije tretiran ali će vreme apsorpcije biti mnogo veće nego nakon tretmana u kiseoniku. Ovim je potvrđeno očekivanje rasta hidrofilnosti nakon tretmana u kiseoniku, što se događa kako zbog fizičkog nagrivanja uzorka tako i zbog implementacije polarnih kiseonikovih grupa na površinu tkanine. Kao što se vidi iz tabele 4.3.1, visok sadržaj kiseonika na površini uzorka se održava čak i posle funkcionalizacije površine u plazmi amonijaka. Izlaganje uzorka prvo kiseoničnoj pa zatim NH_3 plazmi dovodi do određenog pada u hidrofilnosti jer je vreme apsorpcije od 0,95 s skoro tri puta veće u odnosu na uzorak koji bio tretiran samo kiseonikom ali je i dalje značajno manje od netretiranog uzorka. Iz rezultata koji su prikazani u tabelama 4.3.1 i 4.3.2 može da se zaključi da će tkanine koje su prošle prvo kroz tretman u kiseoničnoj plazmi pa zatim kroz funkcionalizaciju u plazmi amonijaka imati površinu koja je izrazito hidrofilna a na kojoj se takođe nalazi i azot. Ovakva kombinacija osobina bi trebalo da olakšava adsorpciju mikrokapsula.

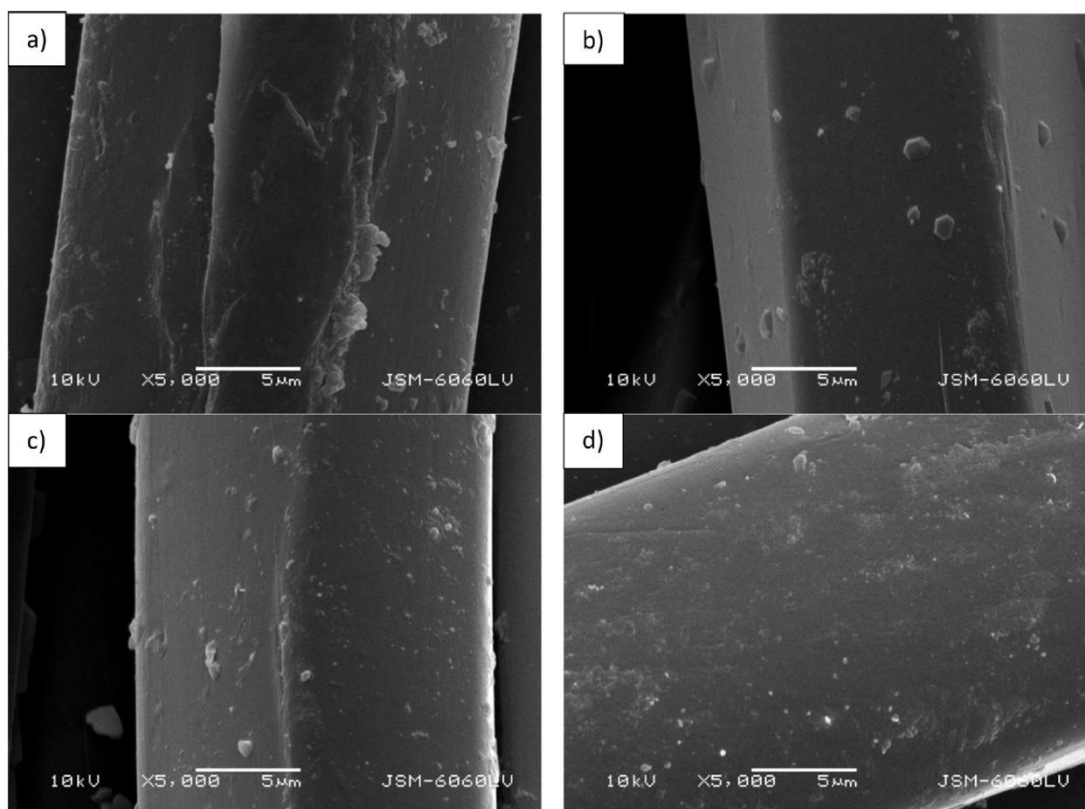

Slika 4.3.2 Snimci uzoraka napravljeni elektronskim mikroskopom (SEM) i to a) netretirani uzorci, b) tretirani 100 s u O_2 a zatim 3 s u NH_3 , c) 100 s O_2 i 243 s NH_3 i d) 200 s O_2 i 243 s NH_3 .

Snimci uzoraka koji su napravljeni elektronskim mikroskopom (SEM) su prikazani na slici 4.3.2. U gornjem levom delu slike (4.3.2 a)) je prikazan netretirani uzorak. Zanimljivo je da su na površini vlakna PET tkanine vidljive nečistoće. Na slikama 4.3.2 b) i c) su prikazani snimci uzoraka koji su tretirani 100 s u kiseoniku a potom 3 odnosno 243 s u amonijaku. Može da se primeti da je tretmanom postignuto čišćenje uzoraka i da je ono bilo uspešnije nakon dužeg tretmana. Morfološke

Mikrotalasno pražnjenje

promene površine uzoraka, kao posledica nagrivanja, su jasno vidljive tek na uzorcima koji su kiseoniku proveli 200 s u kiseoniku i još 243 s u amonijaku i one su predstavljene na slici 4.3.2 d).

Uzorci su snimljeni elektronskim mikroskopom i nakon što su na njih nanete mikrokapsule a rezultat je prikazan na slici 4.3.3. Predstavljani su netretirani uzorak (na slici 4.3.3 a)), uzorak koji je tretiran 100 s u kiseoniku i zatim 243 s u amonijaku (4.3.3 b)) i uzorak koji je tretiran 200 s u kiseoniku i zatim 234 s u amonijaku. Omotač mikrokapsula sa površinom PET tkanine može da interaguje samo ukoliko se na njegovoj površini nalaze reaktivne grupe koje bi se kovalentnom vezom spojile sa funkcionalnim grupama na površini uzorka. Zbog toga nije iznenađenje što je najmanje mikrokapsula adsorbovano na netretiranom uzorku (4.3.3 a)). S obzirom na to da se nakon tretmana povećava količina funkcionalnih grupa na površini vlakana ali i da sam uzorak postaje znatno hidrofilniji, što olakšava svaku vrstu bojenja, na tretiranim uzorcima će broj mikrokapsula biti znatno veći. Na slici 4.3.3 može da se primeti da je uzorak koji je kiseonikom tretiran 200 s adsorbovao nešto više mikrokapsula od uzorka koji mu je bio izložen samo 100 s.

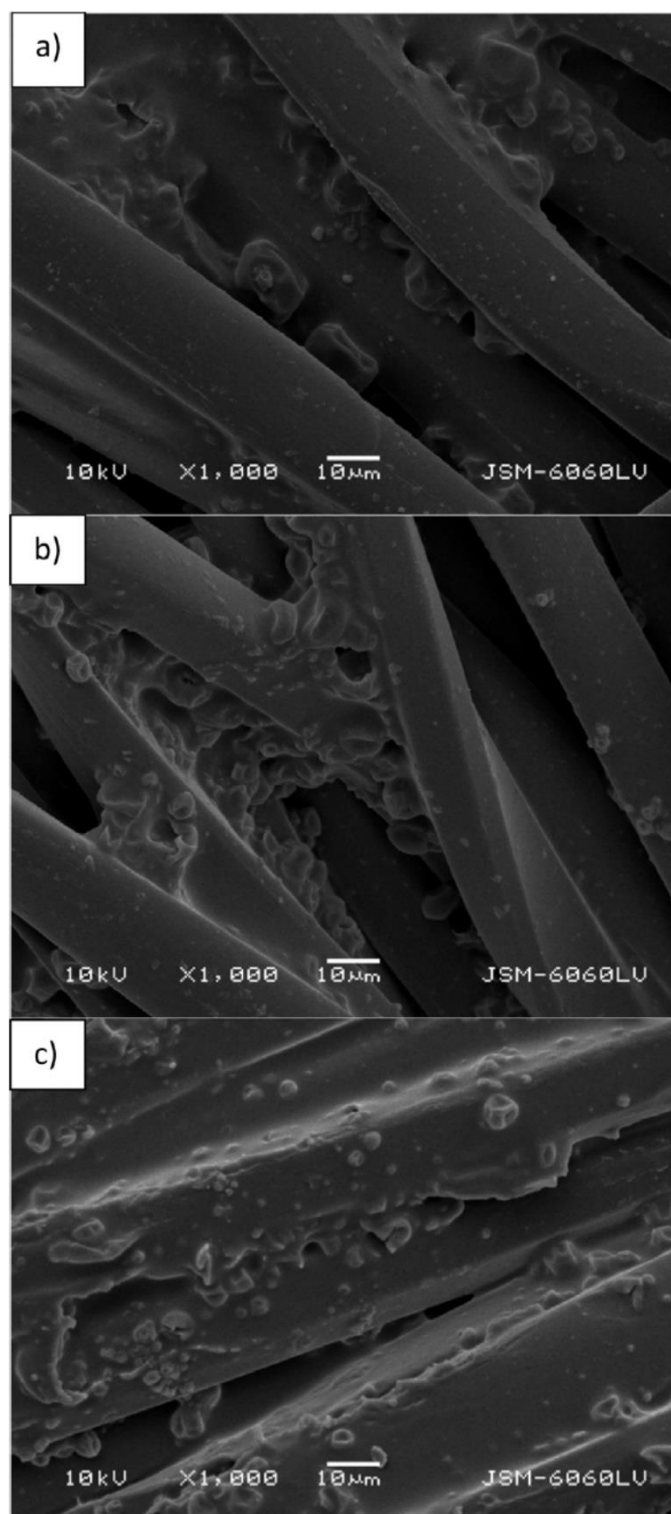

Slika 4.3.3 Snimci uzoraka napravljeni elektronskim mikroskopom (SEM) nakon procedure nanošenja mikrokapsula: a) netretirani uzorak, b) 100 s O₂ i 243 s NH₃ i c) 200 s O₂ i 243 s NH₃.

Sposobnost uzoraka da propuste vazduh, odnosno vazдушna permeabilnost je prikazana na slici 4.3.4. Najpropusniji je bio uzorak koji nije bio tretiran (UN). Posle tretmana samo u kiseoniku permeabilnost je opala za 2,13 % dok je nakon tretmana u amonijaku taj pad iznosio 3,21 %. Vazдушna permeabilnost je značajnije opala nakon kombinovanog tretmana u oba gasa i bila je najmanja, 9,56 % manja od početne, posle 200 s kiseoničnog i 243 s NH₃ tretmana. Ovi rezultati su očekivani ukoliko se pogleda povećanje mase uzorka nakon nanošenja mikrokapsula koje je, u

Mikrotalasno pražnjenje

zavisnosti od vrste tretmana, prikazano na slici 4.3.5. Netretirani uzorak je svoju masu povećao za svega 1,31 % dok je uzorak koji je tretiran 200 s u kiseoniku pa zatim 243 s u amonijaku povećao masu za skoro 11 %. Više dodate mase znači da se na uzorku nalazi veći broj mikrokapsula koje mogu da popune sitne otvore u strukturi tkanine i time blokiraju protok vazduha kroz nju, što je i pokazano na slici 4.3.4.

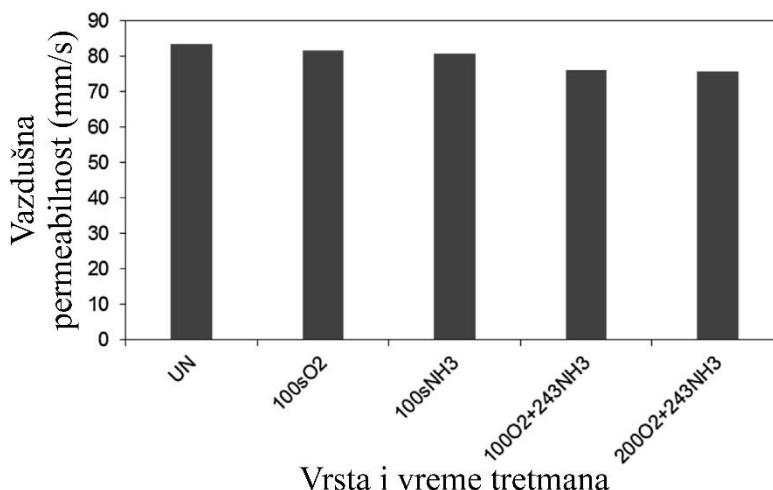

Slika 4.3.4 Vazдушna permeabilnost uzoraka testirana sa padom pritiska od 100 Pa za uzorke koji su tretirani po 100 s samo u kiseoniku ili samo amonijaku i one koji su tretirani po 243 s u amonijaku nakon tretmana od 100 ili 200 s u kiseoniku. UN – uzorak netretiran.

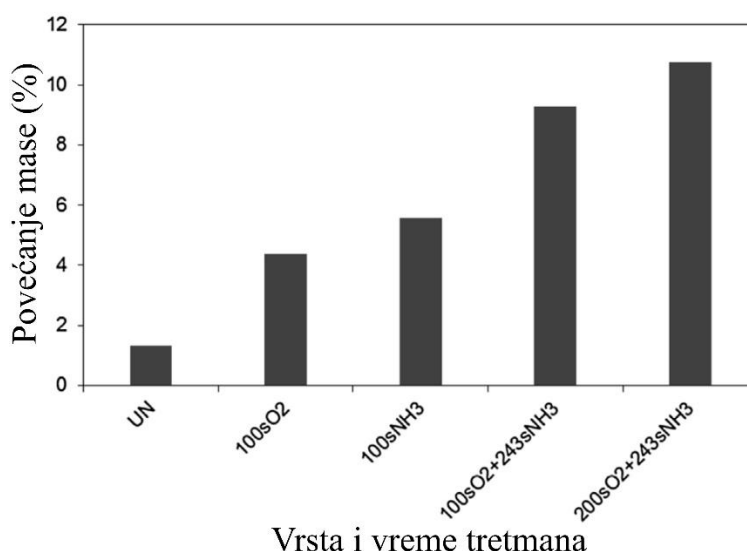

Slika 4.3.5 Povećanje mase tkanine nakon adsorpcije mikrokapsule za uzorke koji su tretirani po 100 s samo u kiseoniku ili samo amonijaku i one koji su tretirani po 243 s u amonijaku nakon tretmana od 100 ili 200 s u kiseoniku. UN – uzorak netretiran.

Uspešnost tretmana, odnosno kvalitet adsorpcije mikrokapsula, može da se proceni i preko promene boje uzoraka. U odnosu na netretiran uzorak, svi oni koji su tretirani će imati boju koja se prema CIELAB sistemu opisuje kao tamnija (L^* vrednost), malo više zelena (a^* - osa) i nešto žuća (b^* - osa). Međutim, najverodostojniji test uspešnosti tretmana UV-osetljivim mikrokapsulama se dobija ako se izmeri promena boje tkanine, ΔE_{ab}^* , pre i posle izlaganja ultraljubičastoj svetlosti. Na

ovaj način se proveravaju i fotokromne performanse samih mikrokapsula. Ukoliko je ova promena veća to znači da fotokromna boja ima veću sposobnost da, nakon izlaganja UV zračenju, re-aranžiranjem veza među atomima, promeni boju bezbojnom molekulu, odnosno, u našem slučaju, da je količina mikrokapsula na uzorku veća. Na slici 4.3.6 je prikazana promena boje tretiranih uzoraka u odnosu na netretirani. Najmanja razlika se uočava na uzorcima koji su tretirani samo u kiseoničnoj plazmi. Skoro dvostruko veća razlika je vidljiva na tkanini koja je tretirana samo u amonijaku dok se najveća razlika u boji vidi na uzorcima koji su posle 200 s tretmana u kiseoniku tretirani još 243 s u amonijaku. U tim uzorcima je, kao što je prikazano u tabeli 4.3.1, i najveća koncentracija azota na površini. S obzirom na to da se ΔE_{ab}^* nalazi u opsegu od 2 do 7, ove promene u boji su vidljive i ljudskom oku.

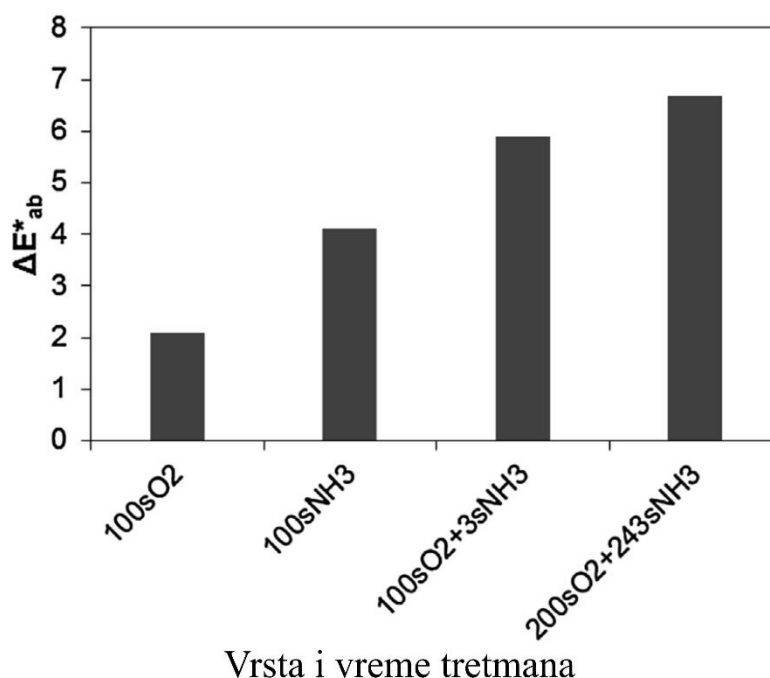

Slika 4.3.6 Promena boje ΔE_{ab}^* tretiranih uzoraka u odnosu na netretirane, prema CIELAB sistemu, nakon izlaganja UV zračenju.

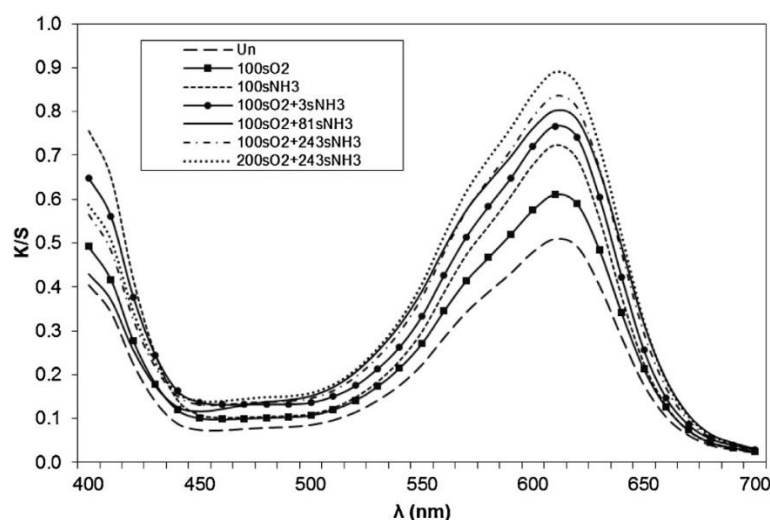

Slika 4.3.7 K/S vrednosti, odnosno jačina boje, tretiranih i netretiranih uzoraka nakon izlaganja UV zračenju.

Iako se iz predstavljenih rezultata jasno vidi da je postupak nanošenja mikrokapsula uspešan, radi kompletnosti predstavljamo i poređenja K/S vrednosti tretiranih i netretiranih uzoraka, slika 4.3.7 i promenu dubine boje tretiranih uzoraka u odnosu na netretirani, slika 4.3.8. Jačinom boje, odnosno K/S vrednošću, se opisuje sposobnost uzoraka da svetlost apsorbuju ili reflektuju. Ukoliko je ova vrednost veća to znači da se na njemu nalazi više sredstva za bojenje, odnosno u našem slučaju mikrokapsula. U predstavljenim rezultatima, za uzorke koji su izloženi UV zračenju, se skok K/S vrednosti pojavljuje na talasnoj dužini od 610 nm, jer boja koja se nalazi u kapsulama (ITOFINISH UV) ima jaku apsorpciju upravo na ovoj talasnoj dužini. Kao što je i očekivano, najmanji intenzitet ovog lokalnog maksimuma imaju uzorci koji nisu tretirani. Sledeći po intenzitetu su uzorci koji su tretirani samo u kiseoniku dok je za uzorke koji su tretirani samo u amonijaku ova vrednost značajno veća. Kod uzoraka koji su tretirani u oba gasa će vrednost maksimuma K/S vrednosti biti veća ukoliko je tretman u amonijaku bio duži. Najviša vrednost je, ipak, zabeležena za uzorke koji su bili tretirani 200 s u kiseoniku i posle toga još 243 s u amonijaku.

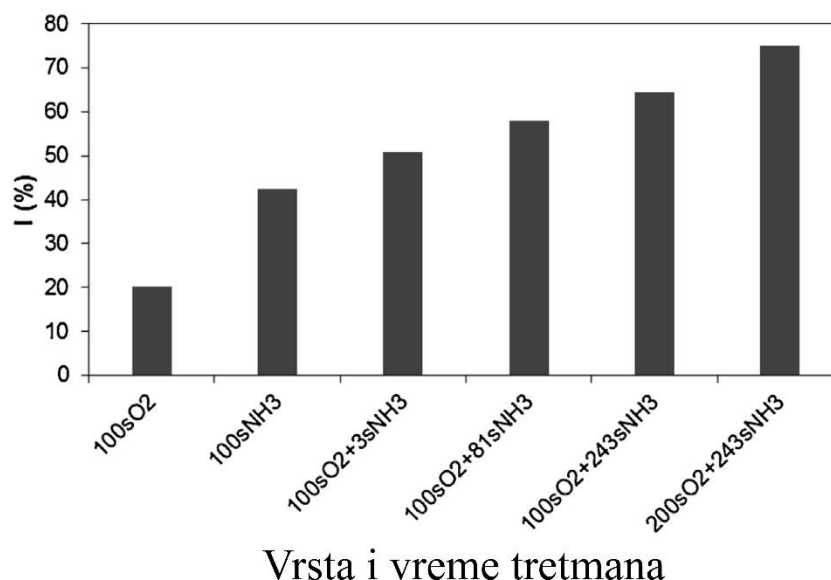

Slika 4.3.8 Promena dubina boje, I, tretiranih uzoraka u odnosu na netretirani izražena u procentima.

Promena dubina boje tretiranih uzoraka u odnosu na netretirani, slika 4.3.8, iznosi 20 % već nakon tretmana od 100 s samo u kiseoniku dok nakon tretmana samo u amonijaku ona iznosi oko 40 %. Iz ovih rezultata se, takođe, može videti da se najveća razlika postiže ukoliko se tretman obavi prvo u kiseoniku pa zatim u azotu. Ukoliko se posle O₂ tretmana uzorak tretira samo tri sekunde u amonijaku, poboljšanje iznosi već oko 50 što je više nego dupla razlika u odnosu na tretman samo u kiseoniku. Ova razlika će biti sve veća ukoliko je uzorak bio duže tretiran u amonijaku i dostiže maksimalnih 75 % za tretman od 200 s O₂ + 243 s NH₃.

4.3.3 ZAKLJUČAK

U ovom poglavlju smo predstavili metod za poboljšanje apsorpcije UV responsivnih mikrokapsula na površinu veštačke PET tkanine. Iz literature je poznato da se posle tretmana u kiseoničnoj plazmi bilo kakvo bojenje tkanina obavlja uspešnije zbog povećanja hidrofilitnosti površine i zbog postojanja polarnih kiseonikovih grupa. Takođe, nanošenje mikrokapsula je uspešnije

na površini na kojoj se nalaze funkcionalne azotove grupe. Kako bi objedinili ove faktore pretpostavili smo da bi se apsorpcija povećala ukoliko se tkanina tretira prvo u kiseoniku a zatim i u amonijaku. Merenjem vremena potrebnog za apsorpciju vode smo potvrdili povećanje hidrofilitnosti samo nakon tretmana u kiseoniku. Merenjem promene mase uzoraka, njihove vazdušne permeabilnosti ali i snimcima elektronskim mikroskopom (SEM) ustanovili smo da do najveće apsorpcije mikrokapsula dolazi nakon najdužih tretmana, odnosno nakon 200 s izlaganja kiseoniku koje je praćeno sa još 243 s tretmana u amonijaku. Ovi rezultati su potvrđeni testovima promene boje nakon izlaganja tkanine UV zračenju. Promene dubine boje, K/S vrednosti i ΔE_{ab}^* su takođe bili najintenzivniji nakon pomenutih uslova tretmana. Bitno je naglasiti da se veće razlike primećuju povećanjem NH_3 tretmana nego dupliranjem vremena izlaganja kiseoniku.

4.4 ZAKLJUČAK

Četvrta glava disertacije bila je posvećena reaktoru koji je konstruisan tako da se izvor aktivnih čestica ne nalazi u njegovoj zapremini. Koncentracija atomskog kiseonika je merena na tri različite pozicije a ispitano je i kako ona zavisi od širine konusa na kraju cevi kojom se gasovi uvode u komoru. Tokom ovih merenja je kao radni gas korišćen čist kiseonik. Dodatno, predstavljen je i metod za poboljšanje apsorpcije mirisnih mikrokapsula na površinu tekstilnih uzoraka.

Pokazano da je koncentracija O atoma neravnomerna u unutrašnjosti reaktora i da u najvećoj meri zavisi od protoka radnog gasa. Najviše atoma je detektovano na poziciji koja je najbliža centralnom toku gasova. Manja koncentracija je izmerena na poziciji koja se nalazi u nivou otvora za uvod gasova jer, zbog geometrije reaktora, atomi ne mogu lako da stignu do nje. Odnosno treba da pređu veliki put tokom kog dožive i veliki broj sudara. U određenom broju sudara dolazi do rekombinacije kojom se broj atoma smanjuje. Najmanja koncentracija je izmerena na najnižoj poziciji jer se ona nalazi u blizini donje, metalne, ploče reaktora koja se ponaša kao ponor za atome.

U dogovoru sa kolegama sa Tehnološkog fakulteta iz Ljubljane tretman tkanine je rađen prvo u kiseoniku a zatim, bez otvaranja komore i vađena uzorka, u amonijaku. Kombinovanim tretmanom su postignuti značajno bolji rezultati nego pojedinačnim tretmanima u kiseoniku ili amonijaku. Došlo je do poboljšanja fizičkih osobina materijala i uspešnije apsorpcije mikrokapsula a promene su bile utoliko veće ukoliko je tretman duže trajao. Poređenjem efekata koji na uzorke ostavlja tretman kiseonikom i amonijakom je zaključeno da do značajnijih promena dolazi ukoliko se produži vreme izlaganja amonijaku.

5 ZAKLJUČAK

Istraživanja čiji su rezultati predstavljani u ovoj disertaciji imala su za cilj, pre svega, produblјivanje znanja o fundamentalnim procesima u pražnjenjima na niskom pritisku. Akcenat je bio na električnim osobinama sistema i interakciji plazme sa površinama. Dodatno je ispitan efekat koji ovakva pražnjenja imaju na termalno osetljive uzorke poput semena biljaka i tekstila, a imajući u vidu veliki potencijal za primenu u industriji, ispitivani su uslovi u kojima se željeni efekti tretmana postižu sa najmanjim utroškom vremena i energije. Eksperimenti su rađeni u tri različita tipa reaktora i svakome od njih je bila posvećena jedna glava disertacije.

Asimetričnom reaktoru velike zapremine i cilindrične simetrije je bila posvećena druga glava. Istraživanja su rađena za dve različite dimenzije uzemljenih elektroda čime je omogućeno da se ispita efekat odnosa površine uzemljene i napajane elektrode na osobine pražnjenja. Dvodimenzionalnom simulacijom je ustanovljeno da prisustvo dodatne elektrode, manjeg poluprečnika, neće značajno da utiče na količinu i brzinu gasova u centralnom delu reaktora. Merenjem električnih osobina je pokazano da smanјivanje prečnika uzemljene elektrode dovodi do smanјivanja RMS vrednosti napona i efikasnosti predaje snage plazmi ali da će RMS vrednosti struje biti veće. Takođe, dolazi do porasta drugog harmonika strujnog signala. Zaključili smo još da u uslovima velikog pritiska i male primenjene snage, kada je aktivna oblast plazme skoncentrisana oko napajane elektrode, ulogu uzemljene elektrode preuzima neutralni gas. Pored toga što je promenjena površina uzemljene elektrode, na merenja masenim spektrometrom značajno utiče i relativna pozicija otvora za uzorkovanje. Tokom merenja sa uzemljenom elektrodom velikog poluprečnika otvor se nalazio u aktivnoj zoni pražnjenja dok je u drugom slučaju on bio u nivou površine uzemljene elektrode. Primenom metode masene spektrometrije praga za jonizaciju je pokazano da se u aktivnom delu pražnjenja nalazi veliki broj pobuđenih molekula kiseonika i nešto manji broj pobuđenih atoma. Međutim, u blizini uzemljenog zida komore je broj pobuđenih molekula značajno manji dok pobuđeni atomi nisu ni detektovani. Time je pokazano da je tokom tretmana, u kojima se zahteva prisustvo pobuđenih čestica, uzorke potrebno postaviti na provodno postolje čime bi se približili aktivnoj oblasti pražnjenja. Koncentracija atomskog kiseonika i stepen disocijacije su procenjeni primenom metode optičke aktinometrije, analizom spektara koji su snimljeni kako sa prednje tako i sa boče strane komore. Ovom metodom je izmeren veći stepen disocijacije nego primenom masene spektrometrije. Razlika postoji zbog suštinski drugačijeg načina merenja. Masena spektrometrija je lokalna metoda, merenje se obavlja u samoj plazmi, dok je aktinometrija beskontaktna, optička metoda, a rezultat predstavlja usrednjenu i vremenski integrisanu vrednost duž vidnog polja.

U asimetričnom reaktoru je tretirano seme caričinog drveta kako bi se procenio efekat plazme na aktivnost enzima katalaze u ranim fazama klijanja. Odvojeno su mereni koncentracija i aktivnost enzima tokom 4 dana klijanja. Pokazano je da tokom prva tri dana dolazi do velikih fluktuacija ali da će nakon četvrtog, poslednjeg dana klijanja, kako aktivnost katalaze tako i njena koncentracija biti veća u onim mladicama čije je seme duže tretirano. Pored vremena izlaganja plazmi važno je i na kom je pritisku tretman rađan. Pokazano je da se tretmanom semena caričinog drveta na višem pritisku postiže veća aktivnost i koncentracija katalaze poslednjeg dana klijanja. Pored pomenutog, tretirano je i seme komercijalnih vrsta biljaka sa ciljem povećanja klijavosti i uklanjanja patogena. Pokazano je da se pažljivim odabirom pritiska, snage i vremena tretmana može postići poboljšanje i kod industrijskog semena koje već ima visok stepen klijavosti. Takođe, u određenom opsegu parametara tretmana, moguće je i značajno smanјiti stepen infekcije. Međutim, ukoliko su uslovi previše intenzivni ili je vreme tretiranja predugačko, dolazi do oštećenja površine semena što može da dovede do pada klijavosti i do povećanja stepena infekcije. U ovakvom reaktoru su tretirani i uzorci pamučne tkanine sa ciljem nanošenja mirisnih mikrokapsula. Upoređeni su efekti koje na pamučnu tkaninu imaju kiseonična i azotna plazma. Na većinu fizičkih osobina uzoraka su oba radna gasa imala veoma sličan efekat, a razlike u odnosu na netretirane uzorke su bile velike. Veće promene

Zaključak

u morfologiji uzoraka su primećene nakon tretmana kiseoničnom plazmom dok je nanošenje mikrokapsula bilo uspješnije na onim uzorcima koji su tretirani u azotu.

Treća glava ove disertacije je bila posvećena analizi pražnjenja i tretmanima u reaktoru plan paralelne geometrije u kome je moguće podešavati rastojanje između uzemljene i napajane elektrode. Električne osobine su, takođe, ispitivane derivativnim sondama. U svim uslovima pražnjenja je strujni signal imao oblik koji je u velikoj meri odstupao od oblika pravilne sinusoide. Analizom frekventnog sastava strujnog signala je ustanovljeno da do toga dolazi zbog intenziteta drugog harmonika koji je bio jednak ili veći od intenziteta harmonika na osnovnoj frekvenciji. Podsetimo se da je smanjenjem površine uzemljene elektrode u asimetričnom reaktoru takođe došlo do „izobličavanja“ strujnog signala zbog porasta intenziteta drugog harmonika. Imajući ovo u vidu, nameće se zaključak da intenzitet drugog harmonika zavisi od odnosa površina uzemljene i napajane elektrode, odnosno da će on biti veći ukoliko je pomenuti odnos manji. U ovakvoj vrsti reaktora, RMS vrednosti struje i napona ne zavise mnogo od rastojanja između elektroda. Efikasnost predaje snage plazmi je, ipak, za najveći opseg parametara nešto veća kada je rastojanje između elektroda bilo veće. Ovakav sistem je, po tom pitanju, manje efikasan od asimetričnog reaktora.

Ispitivanje plan paralelnog reaktora metodom optičke emisije spektroskopije je rađeno kako bi se procenilo u kojoj meri tretirani uzorak može da utiče na osobine plazme. Poređenjem evolucije emisije azotovih linija tokom pražnjenja sa i bez pamučnog uzorka u azotnoj plazmi je primećeno da se intenzitet emisije ne menja ili, zbog grejanja, polako raste kada u komori nema uzorka. Ukoliko je u komori bio uzorak, emisija je bila intenzivnija. Takođe je bio primetan nagli porast u prvim trenucima tretmana koji je, nakon dostignutog maksimuma, bio praćen postepenim padom emisije. Poređenjem emisije tokom tretmana uzoraka od materijala koji su znatno manje hidrofilni, PET tkanine i stakla, pretpostavljeno je da uzrok specifične evolucije azotove linije tokom tretmana pamučnog uzorka leži u količini vode koji uzorak unese u komoru a koja na plazma hemiju utiče tako što olakšava pobuđivanje N_2 molekula. Pretpostavka je delom potvrđena jer je emisiona traka OH radikala primetna samo tokom tretmana pamuka. Emisija ovog radikala je upoređena tokom pražnjenja bez uzorka, tokom tretmana uzorka koji je u vakuumu ostao sat vremena i tokom standardnog tretmana uzorka. Emisija OH trake je bila manja tokom tretmana uzorka koji je proveo sat vremena u vakuumu ali je i tada bila veća nego kada u komori nije bilo uzorka. Treba imati u vidu da u hemijskoj strukturi pamuka postoje OH grupe koje je delovanjem plazme moguće odvojiti od površine materijala. Promene u spektru tokom pražnjenja sa i bez uzorka su značajno manje u argonskoj plazmi. Međutim i tokom pražnjenja u argonu je detektovano prisustvo molekula azota koji u plazmu ulaze desorpcijom sa zidova reaktora. Uniformnost pražnjenja je ispitana Langmirovom sondom merenjima na različitim udaljenostima od centralne ose sistema. Pokazano je da temperatura elektrona zavisi samo od snage i pritiska a da je praktično nezavisna od rastojanja od centralne ose. Međutim, koncentracija elektrona i plazmeni potencijal su u oblasti između ivica elektroda bili mnogo manji nego u centralnom delu reaktora.

Tretman pamučnih uzoraka je rađen u plan paralelnom reaktoru i sa ciljem nanošenja mikrokapsula na njegovu površinu. Tretman je rađen u azotu a rezultati su poređeni sa uzorcima koji nisu uopšte tretirani i sa uzorcima koji su bez uključivanja plazme bili izloženi niskom pritisku u azotu. Efikasnost nanošenja mikrokapsula je bila veća tokom tretmana sa većim rastojanjem između elektroda, što su i uslovi u kojima je predaja snage plazmi bila efikasnija. Pokazano je, kao i tokom tretmana semena u asimetričnom reaktoru, da prevelika snaga može da dovede do oštećenja uzoraka. Na velikoj snazi, tekstilni uzorak je požuteo. FTIR analizom uzoraka je pokazano da tretmanom u azotnoj plazmi dolazi do pojave karbonilnih i N-H grupa na tretiranoj površini. Međutim, N-H grupe su se pojavile i u onim uzorcima koji nisu bili u plazmi ali su proveli određeno vreme na niskom pritisku u azotu. Elektronskim mikroskopom je potvrđen veći broj mikrokapsula u tretiranim uzorcima u odnosu na netretirane.

U poslednjem reaktoru koji je analiziran tokom izrade ove disertacije gasovi se pobuđuju mikrotalasnim surfatronom a u komoru se uvode pomoću staklene cevi. Ovom reaktoru je posvećena

Zaključak

četvrta glava disertacije. Katalitičkom sondom je merena koncentracija atomskog kiseonika na tri specifične pozicije dok su za uvod gasova korišćene cevi koje na svom kraju imaju konuse različitih dimenzija. Pokazano je da je koncentracija O atoma vrlo neravnomerna u zapremini reaktora i da, za fiksirane pozicije, u najvećoj meri zavisi od protoka gasa a u nešto manjoj meri i od dimenzija konusa na kraju cevi za uvod gasova. Na dve od tri pozicije se povećanjem protoka, za fiksnu snagu, postiže porast koncentracije O atoma do određene vrednosti nakon koje ona polako opada. Međutim, na poziciji koja je najbliža donjoj, aluminijumskoj, ploči reaktora zavisnost od protoka ima dvostruki maksimum a ukupne koncentracije su najmanje. Mala količina O atoma je na ovoj poziciji izmerena zbog toga što se površina aluminijuma, zbog rekombinacije, ponaša kao ponor za atome.

Tretmanima tekstila, takođe sa ciljem nanošenja mikrokapsula, u ovom reaktoru je pokazano da se najbolji rezultati postižu ukoliko se uzorci prvo izlože kiseoniku kako bi se površina aktivirala a zatim amonijaku kako bi se na nju ugradile funkcionalne grupe azota. Iako je do porasta hidrofilitnosti dolazilo samo nakon tretmana u kiseoniku, veća efikasnost nanošenja mikro kapsula se postiže dužim vremena tretmana u amonijaku nego produžavanjem kiseoničnog tretmana.

Zaključak

6 LITERATURA

- [1] D. Mihailović *et al.*, “Improved properties of oxygen and argon RF plasma-activated polyester fabrics loaded with TiO₂ nanoparticles,” *ACS Appl. Mater. Interfaces*, vol. 2, no. 6, pp. 1700–1706, Jun. 2010, doi: 10.1021/am100209n.
- [2] I. Filatova, V. Azharonok, V. Lushkevich, A. Zhukovsky, G. Gadzhieva, and K. Spasi, “Plasma seeds treatment as a promising technique for seed germination improvement,” *31st ICPIG*, pp. 4–7, 2013.
- [3] T. Makabe and Z. Petrović, *Plasma electronics: Applications in microelectronic device fabrication*. Taylor & Francis Group, LLC, 2006.
- [4] F. Chen and J. Chang, *Lecture notes on principles of plasma processing*. Springer Science & Business Media, 2012.
- [5] A. Fridman, *Plasma Chemistry*. Cambridge University Press, 2008.
- [6] M. Lieberman, A. and A. Lichtenberg, J., *Principles of Plasma Discharges and Materials Processing*. John Wiley & Sons, Inc.
- [7] Z. Donko, P. Hartmann, and G. J. Kalman, “Strongly Coupled Plasma Liquids,” pp. 1–10, Oct. 2007, [Online]. Available: <http://arxiv.org/abs/0710.5229>.
- [8] K. Chaudhary, S. Z. H. Rizvi, and J. Ali, “Laser-Induced Plasma and its Applications,” *Plasma Sci. Technol. - Prog. Phys. States Chem. React.*, 2016, doi: 10.5772/61784.
- [9] Y. P. Raizer, *Gas Discharge Physics*. New York: Springer-Verlag, 1991.
- [10] N. Škoro, D. Marić, G. Malović, W. G. Graham, and Z. L. Petrović, “Electrical breakdown in water vapor,” *Phys. Rev. E - Stat. Nonlinear, Soft Matter Phys.*, vol. 84, no. 5, pp. 1–4, 2011, doi: 10.1103/PhysRevE.84.055401.
- [11] T. Lafleur, P. Chabert, and J. P. Booth, “Electron heating in capacitively coupled plasmas revisited,” *Plasma Sources Sci. Technol.*, vol. 23, no. 3, 2014, doi: 10.1088/0963-0252/23/3/035010.
- [12] O. A. Popov and V. A. Godyak, “Power dissipated in low-pressure radio-frequency discharge plasmas,” *J. Appl. Phys.*, vol. 57, no. 1, pp. 53–58, 1985, doi: 10.1063/1.335395.
- [13] B. G. Heil, R. P. Brinkmann, and U. Czarnetzki, “The gain and loss of energy by electrons in the RF-CCP sheath,” *J. Phys. D. Appl. Phys.*, vol. 42, no. 8, 2009, doi: 10.1088/0022-3727/42/8/085205.
- [14] D. O’Connell, T. Gans, D. Vender, U. Czarnetzki, and R. Boswell, “Plasma ionization through wave-particle interaction in a capacitively coupled radio-frequency discharge,” *Phys. Plasmas*, vol. 14, no. 3, 2007, doi: 10.1063/1.2717889.
- [15] T. Mussenbrock, R. P. Brinkmann, M. A. Lieberman, A. J. Lichtenberg, and E. Kawamura, “Enhancement of ohmic and stochastic heating by resonance effects in capacitive radio frequency discharges: A theoretical approach,” *Phys. Rev. Lett.*, vol. 101, no. 8, pp. 1–4, 2008, doi: 10.1103/PhysRevLett.101.085004.
- [16] J. K. Olthoff and K. E. Greenberg, “The Gaseous Electronics Conference RF Reference Cell - An Introduction,” *J. Res. Natl. Inst. Stand. Technol.*, vol. 100, no. 4, p. 327, 1995, doi: 10.6028/jres.100.025.
- [17] P. J. Hargis *et al.*, “The Gaseous Electronics Conference radio-frequency reference cell: A defined parallel-plate radio-frequency system for experimental and theoretical studies of

- plasma-processing discharges,” *Rev. Sci. Instrum.*, vol. 65, no. 1, pp. 140–154, 1994, doi: 10.1063/1.1144770.
- [18] J. Griffiths, “A brief history of mass spectrometry,” *Anal. Chem.*, vol. 80, no. 15, pp. 5678–5683, 2008, doi: 10.1021/ac8013065.
- [19] J. Benedikt, A. Hecimovic, D. Ellerweg, and A. Von Keudell, “Quadrupole mass spectrometry of reactive plasmas,” *J. Phys. D. Appl. Phys.*, vol. 45, no. 40, 2012, doi: 10.1088/0022-3727/45/40/403001.
- [20] E. de Hoffmann, “Mass Spectrometry,” in *Kirk-Othmer Encyclopedia of Chemical Technology*, vol. 1040, no. 2, Hoboken, NJ, USA: John Wiley & Sons, Inc., 2005, pp. 1–4.
- [21] G. L. Glish and R. W. Vachet, “The basics of mass spectrometry in the twenty-first century,” *Nat. Rev. Drug Discov.*, vol. 2, no. 2, pp. 140–150, 2003, doi: 10.1038/nrd1011.
- [22] J. B. Fenn, M. Menn, N. C. K. Meng, S. F. Wong, and C. M. Witehouse, “ChemInform Abstract: Electrospray Ionization for Mass Spectrometry of Large Biomolecules,” *ChemInform*, vol. 21, no. 5, Jan. 1990, doi: 10.1002/chin.199005359.
- [23] M. Karas and F. Hillenkamp, “Laser Desorption Ionization of Proteins with Molecular Masses Exceeding 10 000 Daltons,” *Anal. Chem.*, vol. 60, no. 20, pp. 2299–2301, 1988, doi: 10.1021/ac00171a028.
- [24] R. D. Smith, X. Cheng, J. E. Brace, S. A. Hofstadler, and G. A. Anderson, “Trapping, detection and reaction of very large single molecular ions by mass spectrometry,” *Nature*, vol. 369, no. 6476, pp. 137–139, 1994, doi: 10.1038/369137a0.
- [25] R. Chen *et al.*, “Trapping, Detection, and Mass Determination of Coliphage T4 DNA Ions of 108 DA by Electrospray Ionization Fourier Transform Ion Cyclotron Resonance Mass Spectrometry,” *Anal. Chem.*, vol. 67, no. 7, pp. 1159–1163, 1995, doi: 10.1021/ac00103a004.
- [26] W. Henderson and J. Scott McIndoe, *Mass Spectrometry of Inorganic and Organometallic Compounds*. John Wiley & Sons, Inc., 2005.
- [27] S. Barber *et al.*, “Increased Sensitivity in Proton Transfer Reaction Mass Spectrometry by Incorporation of a Radio Frequency Ion Funnel,” *Anal. Chem.*, vol. 84, no. 12, pp. 5387–5391, Jun. 2012, doi: 10.1021/ac300894t.
- [28] K. Tanaka *et al.*, “Protein and polymer analyses up to m/z 100 000 by laser ionization time-of-flight mass spectrometry,” *Rapid Commun. Mass Spectrom.*, vol. 2, no. 8, pp. 151–153, Aug. 1988, doi: 10.1002/rcm.1290020802.
- [29] M. Yamashita and J. B. Fenn, “Negative ion production with the electrospray ion source,” *J. Phys. Chem.*, vol. 88, no. 20, pp. 4671–4675, 1984, doi: 10.1021/j150664a046.
- [30] S. N. Foner and R. L. Hudson, “Mass Spectrometric Studies of Metastable Nitrogen Atoms and Molecules in Active Nitrogen,” *J. Chem. Phys.*, vol. 37, no. 8, pp. 1662–1667, Oct. 1962, doi: 10.1063/1.1733356.
- [31] D. W. Kang, H. L. Kim, and C. H. Kwon, “Determination of the accurate ionization energy and cationic structure of cyanopyrazine by one-photon mass-analyzed threshold ionization spectroscopy,” *Int. J. Mass Spectrom.*, vol. 397–398, pp. 52–57, 2016, doi: 10.1016/j.ijms.2016.02.002.
- [32] R. E. Fox, W. M. Hickam, D. J. Grove, and T. Kjeldaas, “Ionization in a mass spectrometer by monoenergetic electrons,” *Rev. Sci. Instrum.*, vol. 26, no. 12, pp. 1101–1107, 1955, doi: 10.1063/1.1715198.

- [33] J. Pulpytel, F. Arefi-Khonsari, and W. Morscheidt, "Threshold ionization mass spectrometry study of singlet molecular oxygen in the deposition of SnO₂ by PACVD," *J. Phys. D. Appl. Phys.*, vol. 38, no. 9, pp. 1390–1395, 2005, doi: 10.1088/0022-3727/38/9/010.
- [34] S. Agarwal, B. Hoex, M. C. M. Van De Sanden, D. Maroudas, and E. S. Aydil, "Absolute densities of N and excited N₂ in a N₂ plasma," *Appl. Phys. Lett.*, vol. 83, no. 24, pp. 4918–4920, 2003, doi: 10.1063/1.1630843.
- [35] S. Agarwal, G. W. W. Quax, M. C. M. van de Sanden, D. Maroudas, and E. S. Aydil, "Measurement of absolute radical densities in a plasma using modulated-beam line-of-sight threshold ionization mass spectrometry," *J. Vac. Sci. Technol. A Vacuum, Surfaces, Film.*, vol. 22, no. 1, pp. 71–81, 2004, doi: 10.1116/1.1627767.
- [36] G. Willems, J. Benedikt, and A. Von Keudell, "Absolutely calibrated mass spectrometry measurement of reactive and stable plasma chemistry products in the effluent of a He/H₂O atmospheric plasma," *J. Phys. D. Appl. Phys.*, vol. 50, no. 33, 2017, doi: 10.1088/1361-6463/aa77ca.
- [37] J. Benedikt, S. Agarwal, D. Eijkman, W. Vandamme, M. Creatore, and M. C. M. van de Sanden, "Threshold ionization mass spectrometry of reactive species in remote Ar/C₂H₂ expanding thermal plasma," *J. Vac. Sci. Technol. A Vacuum, Surfaces, Film.*, vol. 23, no. 5, pp. 1400–1412, 2005, doi: 10.1116/1.2006138.
- [38] S. A. Carl, M. Van Poppel, and J. Peeters, "Identification of the CH + O₂ → OH(A) + CO Reaction as the Source of OH(A-X) Chemiluminescence in C₂H₂/O₂ Atomic Flames and Determination of Its Absolute Rate Constant over the Range T = 296 to 511 K," *J. Phys. Chem. A*, vol. 107, no. 50, pp. 11001–11007, Dec. 2003, doi: 10.1021/jp035568j.
- [39] S. Davies, J. A. Rees, and D. L. Seymour, "Threshold ionisation mass spectrometry (TIMS): A complementary quantitative technique to conventional mass resolved mass spectrometry," *Vacuum*, vol. 101, pp. 416–422, 2014, doi: 10.1016/j.vacuum.2013.06.004.
- [40] M. Sode, T. Schwarz-Selinger, W. Jacob, and H. Kersten, "Wall loss of atomic nitrogen determined by ionization threshold mass spectrometry," *J. Appl. Phys.*, vol. 116, no. 19, pp. 1–14, 2014, doi: 10.1063/1.4902063.
- [41] M. A. Sobolewski, "Electrical Characteristics of Argon Radio Frequency Glow Discharges in an Asymmetric Cell," *IEEE Trans. Plasma Sci.*, vol. 23, no. 6, pp. 1006–1022, 1995, doi: 10.1109/27.476490.
- [42] M. A. Sobolewski, "Electrical characterization of radio-frequency discharges in the Gaseous Electronics Conference Reference Cell," *J. Vac. Sci. Technol. A Vacuum, Surfaces, Film.*, vol. 10, no. 6, pp. 3550–3562, 1992, doi: 10.1116/1.577783.
- [43] P. A. Miller, H. Anderson, and M. P. Splichal, "Electrical isolation of radio-frequency plasma discharges," *J. Appl. Phys.*, vol. 71, no. 3, pp. 1171–1176, 1992, doi: 10.1063/1.351283.
- [44] P. A. Miller, "Electrical characterization of rf plasmas," in *Process Module Metrology, Control and Clustering*, Jan. 1992, vol. 1594, pp. 179–188, doi: 10.1117/12.56631.
- [45] N. Puač, Z. L. Petrović, M. Radetić, and A. Djordjević, "Low Pressure RF Capacitively Coupled Plasma Reactor for Modification of Seeds, Polymers and Textile Fabrics," *Mater. Sci. Forum*, vol. 494, pp. 291–296, Sep. 2005, doi: 10.4028/www.scientific.net/MSF.494.291.
- [46] N. Puač *et al.*, "Measurements of voltage–current characteristics of a plasma needle and its effect on plant cells," *J. Phys. D. Appl. Phys.*, vol. 39, no. 16, pp. 3514–3519, Aug. 2006,

doi: 10.1088/0022-3727/39/16/S09.

- [47] V. N. Volynets *et al.*, “Experimental study of spatial nonuniformities in 100MHz capacitively coupled plasma using optical probe,” *J. Vac. Sci. Technol. A Vacuum, Surfaces, Film.*, vol. 26, no. 3, pp. 406–415, 2008, doi: 10.1116/1.2899413.
- [48] W. Pietsch, A. Petit, and A. Briand, “Isotope ratio determination of uranium by optical emission spectroscopy on a laser-produced plasma - basic investigations and analytical results,” *Spectrochim. acta, Part B At. Spectrosc.*, vol. 53, no. 5, pp. 751–761, 1998, doi: 10.1016/S0584-8547(97)00123-7.
- [49] Y. Liou and Y. R. Ma, “Diamond formation in the carbon-hydrogen-oxygen system,” *Diam. Relat. Mater.*, vol. 3, no. 4–6, pp. 573–576, 1994, doi: 10.1016/0925-9635(94)90227-5.
- [50] T. T. Chau, “Optical emission spectra of microwave oxygen plasmas and fabrication of SiO₂ films,” *J. Vac. Sci. Technol. B Microelectron. Nanom. Struct.*, vol. 14, no. 1, p. 527, 1996, doi: 10.1116/1.588424.
- [51] H. Lee, Y.-S. Kang, P. S. Lee, and J.-Y. Lee, “Hydrogen plasma treatment on catalytic layer and effect of oxygen additions on plasma enhanced chemical vapor deposition of carbon nanotube,” *J. Alloys Compd.*, vol. 330–332, pp. 569–573, Jan. 2002, doi: 10.1016/S0925-8388(01)01599-7.
- [52] Y. Zhang, Y. Li, Y. Li, S. Yu, H. Li, and J. Zhang, “A novel approach to the pacemaker infection with non-thermal atmospheric pressure plasma,” *Eur. Phys. J. Spec. Top.*, vol. 226, no. 13, pp. 2901–2910, 2017, doi: 10.1140/epjst/e2016-60331-4.
- [53] A. Granier, C. Vallée, A. Goulet, K. Aumaille, and G. Turban, “Experimental investigation of the respective roles of oxygen atoms and electrons in the deposition of SiO₂ in O₂/TEOS helicon plasmas,” *J. Vac. Sci. Technol. A Vacuum, Surfaces, Film.*, vol. 17, no. 5, pp. 2470–2474, 1999, doi: 10.1116/1.581985.
- [54] L. Mochalov *et al.*, “Optical emission spectroscopy of lead sulfide films plasma deposition,” *Spectrochim. Acta - Part A Mol. Biomol. Spectrosc.*, vol. 241, 2020, doi: 10.1016/j.saa.2020.118629.
- [55] V. M. Donnelly *et al.*, “Optical plasma emission spectroscopy of etching plasmas used in Si-based semiconductor processing,” *Plasma Sources Sci. Technol.*, vol. 11, no. 3 A, 2002, doi: 10.1088/0963-0252/11/3A/303.
- [56] D. L. Crintea, U. Czarnetzki, S. Iordanova, I. Koleva, and D. Luggenhölscher, “Plasma diagnostics by optical emission spectroscopy on argon and comparison with Thomson scattering,” *J. Phys. D. Appl. Phys.*, vol. 42, no. 4, 2009, doi: 10.1088/0022-3727/42/4/045208.
- [57] Z. Chen, V. M. Donnelly, D. J. Economou, L. Chen, M. Funk, and R. Sundararajan, “Measurement of electron temperatures and electron energy distribution functions in dual frequency capacitively coupled CF₄/O₂ plasmas using trace rare gases optical emission spectroscopy,” *J. Vac. Sci. Technol. A Vacuum, Surfaces, Film.*, vol. 27, no. 5, pp. 1159–1165, 2009, doi: 10.1116/1.3179162.
- [58] N. Bibinov, H. Halfmann, and P. Awakowicz, “Determination of the electron energy distribution function via optical emission spectroscopy and a Langmuir probe in an ICP,” *Plasma Sources Sci. Technol.*, vol. 17, no. 3, 2008, doi: 10.1088/0963-0252/17/3/035004.
- [59] J. W. Coburn and M. Chen, “Optical emission spectroscopy of reactive plasmas: A method for correlating emission intensities to reactive particle density,” *J. Appl. Phys.*, vol. 51, no. 6, pp. 3134–3136, 1980, doi: 10.1063/1.328060.

- [60] W. G. Wang, Y. Xu, Z. C. Geng, Z. W. Liu, and A. M. Zhu, "Determination of atomic hydrogen density in non-thermal hydrogen plasmas via emission actinometry," *J. Phys. D. Appl. Phys.*, vol. 40, no. 14, pp. 4185–4191, 2007, doi: 10.1088/0022-3727/40/14/013.
- [61] Z. C. Geng, Y. Xu, X. F. Yang, W. G. Wang, and A. M. Zhu, "Atomic hydrogen determination in medium-pressure microwave discharge hydrogen plasmas via emission actinometry," *Plasma Sources Sci. Technol.*, vol. 14, no. 1, pp. 76–82, 2005, doi: 10.1088/0963-0252/14/1/010.
- [62] S. Saloum, M. Naddaf, and B. Alkhaled, "Active species characterization in RF remote oxygen plasma using actinometry OES and electrical probes," *Vacuum*, vol. 85, no. 3, pp. 439–442, 2010, doi: 10.1016/j.vacuum.2010.08.007.
- [63] Z. Liu, S. Li, Q. Chen, L. Yang, and Z. Wang, "Measurement of the O₂ dissociation fraction in RF Low pressure O₂/Ar plasma using optical emission spectrometry," *Plasma Sci. Technol.*, vol. 13, no. 4, pp. 458–461, 2011, doi: 10.1088/1009-0630/13/4/14.
- [64] Y. W. Lee, H. L. Lee, and T. H. Chung, "Dissociation fraction in low-pressure inductively coupled N₂-Ar and O₂-Ar plasmas," *Curr. Appl. Phys.*, vol. 11, no. 5 SUPPL., pp. S187–S191, 2011, doi: 10.1016/j.cap.2011.03.037.
- [65] N. C. M. Fuller, M. V. Malyshev, V. M. Donnelly, and I. P. Herman, "Characterization of transformer coupled oxygen plasmas by trace rare gases-optical emission spectroscopy and Langmuir probe analysis," *Plasma Sources Sci. Technol.*, vol. 9, no. 2, pp. 116–127, May 2000, doi: 10.1088/0963-0252/9/2/304.
- [66] M. V. Malyshev and V. M. Donnelly, "Diagnostics of inductively coupled chlorine plasmas: Measurement of electron and total positive ion densities," *J. Appl. Phys.*, vol. 90, no. 3, pp. 1130–1137, 2001, doi: 10.1063/1.1381044.
- [67] D. Voloshin, A. Kovalev, Y. Mankelevich, O. Proshina, T. Rakhimova, and A. Vasilieva, "Evaluation of plasma density in RF CCP discharges from ion current to Langmuir probe: Experiment and numerical simulation," *Eur. Phys. J. D*, vol. 69, no. 1, 2015, doi: 10.1140/epjd/e2014-50313-2.
- [68] M. Fiebrandt, M. Oberberg, and P. Awakowicz, "Comparison of Langmuir probe and multipole resonance probe measurements in argon, hydrogen, nitrogen, and oxygen mixtures in a double ICP discharge," *J. Appl. Phys.*, vol. 122, no. 1, 2017, doi: 10.1063/1.4991493.
- [69] C. Küllig, T. Wegner, and J. Meichsner, "Spatially resolved Langmuir probe diagnostics in a capacitively coupled radio frequency argon and oxygen plasma," *Plasma Sources Sci. Technol.*, vol. 24, no. 1, 2015, doi: 10.1088/0963-0252/24/1/015027.
- [70] S. Kechkar, P. Swift, S. Kelly, S. Kumar, S. Daniels, and M. Turner, "Investigation of the electron kinetics in O₂ capacitively coupled plasma with the use of a Langmuir probe," *Plasma Sources Sci. Technol.*, vol. 26, no. 6, 2017, doi: 10.1088/1361-6595/aa6c90.
- [71] N. Bilik, R. Anthony, B. A. Merritt, E. S. Aydil, and U. R. Kortshagen, "Langmuir probe measurements of electron energy probability functions in dusty plasmas," *J. Phys. D. Appl. Phys.*, vol. 48, no. 10, 2015, doi: 10.1088/0022-3727/48/10/105204.
- [72] A. Agarwal and M. J. Kushner, "Plasma atomic layer etching using conventional plasma equipment," *J. Vac. Sci. Technol. A Vacuum, Surfaces, Film.*, vol. 27, no. 1, pp. 37–50, 2009, doi: 10.1116/1.3021361.
- [73] E. Vogli, D. Metzler, and G. S. Oehrlein, "Feasibility of atomic layer etching of polymer material based on sequential O₂ exposure and Ar low-pressure plasma-etching," *Appl. Phys. Lett.*, vol. 102, no. 25, pp. 2–6, 2013, doi: 10.1063/1.4812750.

- [74] M. Nitschke *et al.*, “Low pressure plasma-based approaches to fluorocarbon polymer surface modification,” *J. Appl. Polym. Sci.*, vol. 103, no. 1, pp. 100–109, 2007, doi: 10.1002/app.24717.
- [75] N. Anagreh, L. Dorn, and C. Bilke-Krause, “Low-pressure plasma pretreatment of polyphenylene sulfide (PPS) surfaces for adhesive bonding,” *Int. J. Adhes. Adhes.*, vol. 28, no. 1–2, pp. 16–22, 2008, doi: 10.1016/j.ijadhadh.2007.03.003.
- [76] H. Yasuda and Y. Matsuzawa, “Economical advantages of low-pressure plasma polymerization coating,” *Plasma Process. Polym.*, vol. 2, no. 6, pp. 507–512, 2005, doi: 10.1002/ppap.200500002.
- [77] W. Petasch, B. Kegel, H. Schmid, K. Lendenmann, and H. U. Keller, “Low-pressure plasma cleaning: A process for precision cleaning applications,” *Surf. Coatings Technol.*, vol. 97, no. 1–3, pp. 176–181, 1997, doi: 10.1016/S0257-8972(97)00143-6.
- [78] A. S. Korhonen and E. H. Sirvio, “A new low pressure plasma nitriding method,” *Thin Solid Films*, vol. 96, no. 1, pp. 103–108, Oct. 1982, doi: 10.1016/0040-6090(82)90218-8.
- [79] S. Vepřek, J. Patscheider, and J. Elmer, “Restoration and conservation of ancient artifacts: A new area of application of plasma chemistry,” *Plasma Chem. Plasma Process.*, vol. 5, no. 2, pp. 201–209, 1985, doi: 10.1007/BF00566215.
- [80] S. Vepřek, C. Eckmann, and J. T. Elmer, “Recent progress in the restoration of archeological metallic artifacts by means of low-pressure plasma treatment,” *Plasma Chem. Plasma Process.*, vol. 8, no. 4, pp. 445–466, Dec. 1988, doi: 10.1007/BF01016059.
- [81] K. Schmidt-Ott and V. Boissonnas, “Low-Pressure Hydrogen Plasma: an Assessment of its Application On Archaeological Iron,” *Stud. Conserv.*, vol. 47, no. 2, pp. 81–87, Jan. 2002, doi: 10.1179/sic.2002.47.2.81.
- [82] F. Rossi, O. Kylián, H. Rauscher, M. Hasiwa, and D. Gilliland, “Low pressure plasma discharges for the sterilization and decontamination of surfaces,” *New J. Phys.*, vol. 11, 2009, doi: 10.1088/1367-2630/11/11/115017.
- [83] O. Kylián and F. Rossi, “Sterilization and decontamination of medical instruments by low-pressure plasma discharges: Application of Ar/O₂/N₂ ternary mixture,” *J. Phys. D. Appl. Phys.*, vol. 42, no. 8, 2009, doi: 10.1088/0022-3727/42/8/085207.
- [84] X. Liu and P. X. Ma, “Polymeric Scaffolds for Bone Tissue Engineering,” *Ann. Biomed. Eng.*, vol. 32, no. 3, pp. 477–486, Mar. 2004, doi: 10.1023/B:ABME.0000017544.36001.8e.
- [85] M. Nitschke, G. Schmack, A. Janke, F. Simon, D. Pleul, and C. Werner, “Low pressure plasma treatment of poly(3-hydroxybutyrate): Toward tailored polymer surfaces for tissue engineering scaffolds,” *J. Biomed. Mater. Res.*, vol. 59, no. 4, pp. 632–638, 2002, doi: 10.1002/jbm.1274.
- [86] N. V Bhat and G. S. Nadiger, “Nitrogen Morphology Properties,” pp. 685–691, 2015.
- [87] A. . Wróbel, M. Kryszewski, W. Rakowski, M. Okoniewski, and Z. Kubacki, “Effect of plasma treatment on surface structure and properties of polyester fabric,” *Polymer (Guildf).*, vol. 19, no. 8, pp. 908–912, Aug. 1978, doi: 10.1016/0032-3861(78)90197-0.
- [88] M. M. Hossain, A. S. Herrmann, and D. Hegemann, “Plasma hydrophilization effect on different textile structures,” *Plasma Process. Polym.*, vol. 3, no. 3, pp. 299–307, 2006, doi: 10.1002/ppap.200500152.
- [89] T. H. C. Costa, M. C. Feitor, C. Alves, P. B. Freire, and C. M. De Bezerra, “Effects of gas composition during plasma modification of polyester fabrics,” *J. Mater. Process. Technol.*,

vol. 173, no. 1, pp. 40–43, 2006, doi: 10.1016/j.jmatprotec.2005.11.008.

- [90] M. Radetic, P. Jovancic, N. Puac, and Z. L. Petrovic, “Environmental impact of plasma application to textiles,” *J. Phys. Conf. Ser.*, vol. 71, no. 1, 2007, doi: 10.1088/1742-6596/71/1/012017.
- [91] C. Riccardi *et al.*, “A SF 6 RF plasma reactor for research on,” *Plasma Sources Sci. Technol.*, vol. 10, pp. 92–98, 2001.
- [92] P. Chaivan, N. Pasaja, D. Boonyawan, P. Suanpoot, and T. Vilaithong, “Low-temperature plasma treatment for hydrophobicity improvement of silk,” *Surf. Coatings Technol.*, vol. 193, no. 1-3 SPEC. ISS., pp. 356–360, 2005, doi: 10.1016/j.surfcoat.2004.08.144.
- [93] Y. Jayasinghe, C. Jayaweera, R. Botheju, M. Ariyasinghe, U. Gunasekera, and N. Wanasekara, “Flame Retardant Synthetic Fabrics by Low Pressure Plasma Technology,” *MERCon 2019 - Proceedings, 5th Int. Multidiscip. Moratuwa Eng. Res. Conf.*, pp. 727–731, 2019, doi: 10.1109/MERCon.2019.8818949.
- [94] S. Shahidi and M. Ghoranneviss, “Comparison between oxygen and nitrogen plasma treatment on adhesion properties and antibacterial activity of metal coated polypropylene fabrics,” *Fibers Polym.*, vol. 13, no. 8, pp. 971–978, 2012, doi: 10.1007/s12221-012-0971-5.
- [95] Y. A. Timoshina, E. F. Voznesensky, E. S. Tskhay, V. A. Sysoev, I. V. Krasina, and G. N. Kulevtsov, “Modification of surface of textile materials with silver nanoparticles in the radio-frequency induction plasma discharge of low pressure,” *J. Phys. Conf. Ser.*, vol. 1328, no. 1, 2019, doi: 10.1088/1742-6596/1328/1/012083.
- [96] T. Yuranova *et al.*, “Antibacterial textiles prepared by RF-plasma and vacuum-UV mediated deposition of silver,” *J. Photochem. Photobiol. A Chem.*, vol. 161, no. 1, pp. 27–34, 2003, doi: 10.1016/S1010-6030(03)00204-1.
- [97] Y. A. Timoshina, A. V. Trofimov, I. S. Miftakhov, and E. F. Voznesenskii, “Modification of Textile Materials with Nanoparticles Using Low-Pressure High-Frequency Plasma,” *Nanotechnologies Russ.*, vol. 13, no. 11–12, pp. 561–564, 2018, doi: 10.1134/S1995078018060101.
- [98] M. Gorjanc, V. Bukošek, M. Gorenšek, and A. Vesel, “The Influence of Water Vapor Plasma Treatment on Specific Properties of Bleached and Mercerized Cotton Fabric,” *Text. Res. J.*, vol. 80, no. 6, pp. 557–567, 2010, doi: 10.1177/0040517509348330.
- [99] F. Guo, Z. Z. Zhang, W. M. Liu, F. H. Su, and H. J. Zhang, “Effect of plasma treatment of Kevlar fabric on the tribological behavior of Kevlar fabric/phenolic composites,” *Tribol. Int.*, vol. 42, no. 2, pp. 243–249, 2009, doi: 10.1016/j.triboint.2008.06.004.
- [100] K. K. Wong, X. M. Tao, C. W. M. Yuen, and K. W. Yeung, “Low Temperature Plasma Treatment of Linen,” *Text. Res. J.*, vol. 69, no. 11, pp. 846–855, 1999, doi: 10.1177/004051759906901108.
- [101] J. Yip, K. Chan, K. M. Sin, and K. S. Lau, “Low temperature plasma-treated nylon fabrics,” *J. Mater. Process. Technol.*, vol. 123, no. 1, pp. 5–12, 2002, doi: 10.1016/S0924-0136(02)00024-9.
- [102] P. Erra, R. Molina, D. Jovic, M. R. Julia, A. Cuesta, and J. M. D. Tascon, “Shrinkage Properties of Wool Treated with Low Temperature Plasma and Chitosan Biopolymer,” *Text. Res. J.*, vol. 69, no. 11, pp. 811–815, Nov. 1999, doi: 10.1177/004051759906901103.
- [103] M. Radetić, P. Jovančić, N. Puač, Z. L. Petrović, and Z. Šaponjić, “Plasma-induced Decolorization of Indigo-dyed Denim Fabrics Related to Mechanical Properties and Fiber

Surface Morphology,” *Text. Res. J.*, vol. 79, no. 6, pp. 558–565, 2009, doi: 10.1177/0040517508095612.

- [104] J. C. Volin, F. S. Denes, R. A. Young, and S. M. T. Park, “Modification of seed germination performance through cold plasma chemistry technology,” *Crop Sci.*, vol. 40, no. 6, pp. 1706–1718, 2000, doi: 10.2135/cropsci2000.4061706x.
- [105] V. Mildaziene *et al.*, “Response of perennial woody plants to seed treatment by electromagnetic field and low-temperature plasma,” *Bioelectromagnetics*, vol. 37, no. 8, pp. 536–548, 2016, doi: 10.1002/bem.22003.
- [106] E. Bormashenko, R. Grynyov, Y. Bormashenko, and E. Drori, “Cold radiofrequency plasma treatment modifies wettability and germination speed of plant seeds,” *Sci. Rep.*, vol. 2, pp. 3–10, 2012, doi: 10.1038/srep00741.
- [107] M. Selcuk, L. Oksuz, and P. Basaran, “Decontamination of grains and legumes infected with *Aspergillus* spp. and *Penicillium* spp. by cold plasma treatment,” *Bioresour. Technol.*, vol. 99, no. 11, pp. 5104–5109, 2008, doi: 10.1016/j.biortech.2007.09.076.
- [108] I. Filatova, V. Lyushkevich, S. Goncharik, A. Zhukovsky, N. Krupenko, and J. Kalatskaja, “The effect of low-pressure plasma treatment of seeds on the plant resistance to pathogens and crop yields,” *J. Phys. D: Appl. Phys.*, vol. 53, no. 24, 2020, doi: 10.1088/1361-6463/ab7960.
- [109] N. Puač *et al.*, “Activity of catalase enzyme in *Paulownia tomentosa* seeds during the process of germination after treatments with low pressure plasma and plasma activated water,” *Plasma Process. Polym.*, vol. 15, no. 2, p. 1700082, Feb. 2018, doi: 10.1002/ppap.201700082.
- [110] J. Jiang *et al.*, “Effect of cold plasma treatment on seed germination and growth of wheat,” *Plasma Sci. Technol.*, vol. 16, no. 1, pp. 54–58, 2014, doi: 10.1088/1009-0630/16/1/12.
- [111] B. Šerá, I. Gajdová, M. Šerý, and P. Špatenka, “New physicochemical treatment method of poppy seeds for agriculture and food industries,” *Plasma Sci. Technol.*, vol. 15, no. 9, pp. 935–938, 2013, doi: 10.1088/1009-0630/15/9/19.
- [112] B. Šerá *et al.*, “How various plasma sources may affect seed germination and growth,” *Proc. Int. Conf. Optim. Electr. Electron. Equipment, OPTIM*, pp. 1365–1370, 2012, doi: 10.1109/OPTIM.2012.6231880.
- [113] P. Basaran, N. Basaran-Akgul, and L. Oksuz, “Elimination of *Aspergillus parasiticus* from nut surface with low pressure cold plasma (LPCP) treatment,” *Food Microbiol.*, vol. 25, no. 4, pp. 626–632, 2008, doi: 10.1016/j.fm.2007.12.005.
- [114] I. I. Filatova, V. V. Azharonok, S. V. Goncharik, V. A. Lushkevich, A. G. Zhukovsky, and G. I. Gadzhieva, “Effect of rf Plasma Treatment on the Germination and Phytosanitary State of Seeds,” *J. Appl. Spectrosc.*, vol. 81, no. 2, pp. 250–256, 2014, doi: 10.1007/s10812-014-9918-5.
- [115] B. Šerá, P. Špatenka, M. Šerý, N. Vrchotová, and I. Hrušková, “Influence of plasma treatment on wheat and oat germination and early growth,” *IEEE Trans. Plasma Sci.*, vol. 38, no. 10 PART 2, pp. 2963–2968, 2010, doi: 10.1109/TPS.2010.2060728.
- [116] R. Lonlua and S. Sarapirom, “The effect of low-pressure plasma treatment on sunflower seed germination and sprouts growth rate,” *J. Phys. Conf. Ser.*, vol. 1380, no. 1, 2019, doi: 10.1088/1742-6596/1380/1/012157.
- [117] M. Laroussi, “Sterilization of contaminated matter with an atmospheric pressure plasma,”

IEEE Trans. Plasma Sci., vol. 24, no. 3, pp. 1188–1191, 1996, doi: 10.1109/27.533129.

- [118] L. Marsili, S. Espie, J. G. Anderson, and S. J. MacGregor, “Plasma inactivation of food-related microorganisms in liquids,” *Radiat. Phys. Chem.*, vol. 65, no. 4–5, pp. 507–513, 2002, doi: 10.1016/S0969-806X(02)00367-5.
- [119] N. Ulbin-Figlewicz, A. Jarmoluk, and K. Marycz, “Antimicrobial activity of low-pressure plasma treatment against selected foodborne bacteria and meat microbiota,” *Ann. Microbiol.*, vol. 65, no. 3, pp. 1537–1546, 2015, doi: 10.1007/s13213-014-0992-y.
- [120] E. Janić Hajnal *et al.*, “Effect of Atmospheric Cold Plasma Treatments on Reduction of *Alternaria* Toxins Content in Wheat Flour,” *Toxins (Basel)*, vol. 11, no. 12, p. 704, Dec. 2019, doi: 10.3390/toxins11120704.
- [121] U. Schnabel *et al.*, “Decontamination of microbiologically contaminated specimen by direct and indirect plasma treatment,” *Plasma Process. Polym.*, vol. 9, no. 6, pp. 569–575, 2012, doi: 10.1002/ppap.201100088.
- [122] U. Schnabel, R. Niquet, O. Schlüter, H. Gniffke, and J. Ehlbeck, “Decontamination and Sensory Properties of Microbiologically Contaminated Fresh Fruits and Vegetables by Microwave Plasma Processed Air (PPA),” *J. Food Process. Preserv.*, vol. 39, no. 6, pp. 653–662, 2015, doi: 10.1111/jfpp.12273.
- [123] D. Magni, C. Deschenaux, C. Hollenstein, A. Creatore, and P. Fayet, “Oxygen diluted hexamethyldisiloxane plasmas investigated by means of in situ infrared absorption spectroscopy and mass spectrometry,” *J. Phys. D. Appl. Phys.*, vol. 34, no. 1, pp. 87–94, 2001, doi: 10.1088/0022-3727/34/1/315.
- [124] D. Maletić *et al.*, “Detection of atomic oxygen and nitrogen created in a radio-frequency-driven micro-scale atmospheric pressure plasma jet using mass spectrometry,” *Plasma Phys. Control. Fusion*, vol. 54, no. 12, p. 124046, Dec. 2012, doi: 10.1088/0741-3335/54/12/124046.
- [125] L. A. McDonnell and R. M. A. Heeren, “Imaging mass spectrometry,” *Mass Spectrom. Rev.*, vol. 26, no. 4, pp. 606–643, Jul. 2007, doi: 10.1002/mas.20124.
- [126] D. Touboul *et al.*, “Tissue Molecular Ion Imaging by Gold Cluster Ion Bombardment,” *Anal. Chem.*, vol. 76, no. 6, pp. 1550–1559, Mar. 2004, doi: 10.1021/ac035243z.
- [127] M. Farber, R. D. Srivastava, and J. W. Moyer, “Mass-spectrometric determination of the thermodynamics of potassium hydroxide and minor potassium-containing species required in magnetohydrodynamic power systems,” *J. Chem. Thermodyn.*, vol. 14, no. 12, pp. 1103–1113, 1982, doi: 10.1016/0021-9614(82)90032-5.
- [128] M. Gomez, C. Chatillon, and M. Allibert, “Thermodynamics of gaseous and condensed indium oxides by mass spectrometry with controlled oxygen pressure,” *J. Chem. Thermodyn.*, vol. 14, no. 5, pp. 447–459, 1982, doi: 10.1016/0021-9614(82)90137-9.
- [129] Y. Itikawa, “Cross sections for electron collisions with oxygen molecules,” *J. Phys. Chem. Ref. Data*, vol. 38, no. 1, pp. 1–20, 2009, doi: 10.1063/1.3025886.
- [130] S. Banon, C. Chatillon, and M. Allibert, “High Temperature Mass Spectrometric Study of Ionization and Fragmentation of TiO and TiO₂ Gas Under Electron Impact,” *High Temp. Sci.*, vol. 15, no. 1, pp. 17–40, 1982.
- [131] R. C. Paule, “Mass Spectrometric Studies of Alumina Vaporization Processes,” *High Temp. Sci.*, 1976.
- [132] H. W. M., M. R., and R. . Lide David, *Handbook of Chemistry and Physics, 94th Edition*

[Online]. 2010.

- [133] Y. Itikawa and A. Ichimura, “Cross Sections for Collisions of Electrons and Photons with Atomic Oxygen,” *J. Phys. Chem. Ref. Data*, vol. 19, no. 3, pp. 637–651, 1990, doi: 10.1063/1.555857.
- [134] R. R. Laher and F. R. Gilmore, “Updated Excitation and Ionization Cross Sections for Electron Impact on Atomic Oxygen,” *J. Phys. Chem. Ref. Data*, vol. 19, no. 1, pp. 277–305, Jan. 1990, doi: 10.1063/1.555872.
- [135] M. B. Schulman, F. A. Sharpton, S. Chung, C. C. Lin, and L. W. Anderson, “Emission from oxygen atoms produced by electron-impact dissociative excitation of oxygen molecules,” *Phys. Rev. A*, vol. 32, no. 4, pp. 2100–2116, Oct. 1985, doi: 10.1103/PhysRevA.32.2100.
- [136] J. E. Chilton, J. B. Boffard, R. S. Schappe, and C. C. Lin, “Measurement of electron-impact excitation into the 3p54p levels of argon using Fourier-transform spectroscopy,” *Phys. Rev. A*, vol. 57, no. 1, pp. 267–277, Jan. 1998, doi: 10.1103/PhysRevA.57.267.
- [137] N. Puač, “Razvoj i dijagnostika radio-frekventne plazme za poboljšanje klijanja semena,” Univerzitet u Beogradu, 2003.
- [138] B. Bora, H. Bhuyan, M. Favre, E. Wyndham, H. Chuaqui, and M. Kakati, “Measurements of time average series resonance effect in capacitively coupled radio frequency discharge plasma,” *Phys. Plasmas*, vol. 18, no. 10, pp. 1–7, 2011, doi: 10.1063/1.3646317.
- [139] A. Rawat, A. Ganguli, R. Narayanan, and R. D. Tarey, “A novel ex situ diagnostic technique for characterizing harmonics in radio frequency discharges,” *Rev. Sci. Instrum.*, vol. 91, no. 9, 2020, doi: 10.1063/5.0009015.
- [140] T. M. Minea, J. Bretagne, D. Pagnon, and M. Touzeau, “Electrical characterization of an rf planar magnetron in inert gases,” *J. Phys. D. Appl. Phys.*, vol. 33, no. 15, pp. 1884–1893, 2000, doi: 10.1088/0022-3727/33/15/319.
- [141] A. I. Moktadir Alam, “CFD Analysis for Rigid Moving Body at the High Tidal Environment of Sea-bed,” Pekan, Pahang, Malaysia, 2014.
- [142] M. Simka and P. Latacz, “Numerical modeling of blood flow in the internal jugular vein with the use of computational fluid mechanics software,” *Phlebol. J. Venous Dis.*, vol. 36, no. 7, pp. 541–548, Aug. 2021, doi: 10.1177/0268355521996087.
- [143] F. Gauvin, V. Caprai, Q. L. Yu, and H. J. H. Brouwers, “Effect of the morphology and pore structure of porous building materials on photocatalytic oxidation of air pollutants,” *Appl. Catal. B Environ.*, vol. 227, no. December 2017, pp. 123–131, 2018, doi: 10.1016/j.apcatb.2018.01.029.
- [144] K. Carpenter, “Hydraulic modeling and computational fluid dynamics of bone burial in a sandy river channel,” *Geol. Intermt. West*, vol. 7, pp. 97–120, Apr. 2020, doi: 10.31711/giw.v7.pp97-120.
- [145] Y. Minamoto, “Flowsquare 4.0: Theory and Computation,” no. December, 2013.
- [146] D. Štular *et al.*, “Influence of non-thermal plasma treatment on the adsorption of a stimuli-responsive nanogel onto polyethylene terephthalate fabric,” *Prog. Org. Coatings*, vol. 120, no. March, pp. 198–207, 2018, doi: 10.1016/j.porgcoat.2018.03.023.
- [147] F. Rombaldoni *et al.*, “Adhesion enhancement of electrospun nanofiber mats to polypropylene nonwoven fabric by low-temperature oxygen plasma treatment,” *Surf. Coatings Technol.*, vol. 216, pp. 178–184, 2013, doi: 10.1016/j.surfcoat.2012.11.056.

- [148] D. Sun and G. K. Stylios, “Effect of Low Temperature Plasma Treatment on the Scouring and Dyeing of Natural Fabrics,” *Text. Res. J.*, vol. 74, no. 9, pp. 751–756, 2004, doi: 10.1177/004051750407400901.
- [149] K. Narushima, N. Yamashita, M. Fukuoka, N. Inagaki, Y. Isono, and M. R. Islam, “Surface modifications of polyester films by ammonia plasma,” *Japanese J. Appl. Physics, Part 1 Regul. Pap. Short Notes Rev. Pap.*, vol. 46, no. 7 A, pp. 4238–4245, 2007, doi: 10.1143/JJAP.46.4238.
- [150] A. Calvimontes, P. Mauersberger, M. Nitschke, V. Dutschk, and F. Simon, “Effects of oxygen plasma on cellulose surface,” *Cellulose*, vol. 18, no. 3, pp. 803–809, 2011, doi: 10.1007/s10570-011-9511-5.
- [151] J. T. Gudmundsson and H. Hannesdóttir, “On the role of metastable states in low pressure oxygen discharges,” *AIP Conf. Proc.*, vol. 1811, 2017, doi: 10.1063/1.4975734.
- [152] S. N. Foner and R. L. Hudson, “Metastable oxygen molecules produced by electrical discharges,” *J. Chem. Phys.*, vol. 25, no. 3, pp. 601–602, 1956, doi: 10.1063/1.1743000.
- [153] B. V. Zhdanov, D. K. Neumann, R. J. Knize, and M. P. Murdough, “Direct measurement of the deactivation rate of excited singlet sigma and singlet delta molecular oxygen by oxygen,” in *Technical Digest. Summaries of papers presented at the Quantum Electronics and Laser Science Conference. Postconference Technical Digest (IEEE Cat. No.01CH37172)*, 2001, pp. 182–183, doi: 10.1109/QELS.2001.962040.
- [154] M. B. Knickelbein, K. L. Marsh, O. E. Ulrich, and G. E. Busch, “Energy transfer kinetics of singlet molecular oxygen: The deactivation channel for O₂(b 1Σ_g⁺) [1],” *J. Chem. Phys.*, vol. 87, no. 4, pp. 2392–2393, 1987, doi: 10.1063/1.453120.
- [155] S. Bowman, I. V. Adamovich, and W. R. Lempert, “Effect of singlet delta oxygen production on the kinetics of low temperature repetitively pulsed nonequilibrium plasmas,” *49th AIAA Aerosp. Sci. Meet. Incl. New Horizons Forum Aerosp. Expo.*, vol. 2, no. 2, 2011, doi: 10.2514/6.2011-968.
- [156] J. T. Gudmundsson, “Recombination and detachment in oxygen discharges: The role of metastable oxygen molecules,” *J. Phys. D. Appl. Phys.*, vol. 37, no. 15, pp. 2073–2081, 2004, doi: 10.1088/0022-3727/37/15/005.
- [157] A. Proto and J. T. Gudmundsson, “The role of surface quenching of the singlet delta molecule in a capacitively coupled oxygen discharge,” *Plasma Sources Sci. Technol.*, vol. 27, no. 7, 2018, doi: 10.1088/1361-6595/aaca06.
- [158] B. B. Fischer, É. Hideg, and A. Krieger-Liszkay, “Production, detection, and signaling of singlet oxygen in photosynthetic organisms,” *Antioxidants Redox Signal.*, vol. 18, no. 16, pp. 2145–2162, 2013, doi: 10.1089/ars.2012.5124.
- [159] A. Danon, O. Miersch, G. Felix, R. G. L. Op Den Camp, and K. Apel, “Concurrent activation of cell death-regulating signaling pathways by singlet oxygen in *Arabidopsis thaliana*,” *Plant J.*, vol. 41, no. 1, pp. 68–80, 2005, doi: 10.1111/j.1365-313X.2004.02276.x.
- [160] F. Ramel, S. Birtic, C. Ginies, L. Soubigou-Taconnat, C. Triantaphylidès, and M. Havaux, “Carotenoid oxidation products are stress signals that mediate gene responses to singlet oxygen in plants,” *Proc. Natl. Acad. Sci. U. S. A.*, vol. 109, no. 14, pp. 5535–5540, 2012, doi: 10.1073/pnas.1115982109.
- [161] T. P. A. Devasagayam and J. P. Kamat, “Biological significance of singlet oxygen,” *Indian J. Exp. Biol.*, vol. 40, no. 6, pp. 680–692, 2002.

- [162] H. K. Ledford, B. L. Chin, and K. K. Niyogi, "Acclimation to singlet oxygen stress in *Chlamydomonas reinhardtii*," *Eukaryot. Cell*, vol. 6, no. 6, pp. 919–930, 2007, doi: 10.1128/EC.00207-06.
- [163] U. Leisinger *et al.*, "The glutathione peroxidase homologous gene from *Chlamydomonas reinhardtii* is transcriptionally up-regulated by singlet oxygen," *Plant Mol. Biol.*, vol. 46, no. 4, pp. 395–408, 2001, doi: 10.1023/A:1010601424452.
- [164] B. B. Fischer *et al.*, "Function and regulation of the glutathione peroxidase homologous gene GPXH/GPX5 in *Chlamydomonas reinhardtii*," *Plant Mol. Biol.*, vol. 71, no. 6, pp. 569–583, 2009, doi: 10.1007/s11103-009-9540-8.
- [165] D. B. Graves, "The emerging role of reactive oxygen and nitrogen species in redox biology and some implications for plasma applications to medicine and biology," *J. Phys. D. Appl. Phys.*, vol. 45, no. 26, p. 263001, Jul. 2012, doi: 10.1088/0022-3727/45/26/263001.
- [166] H. Singh, J. W. Coburn, and D. B. Graves, "Appearance potential mass spectrometry: Discrimination of dissociative ionization products," *J. Vac. Sci. Technol. A Vacuum, Surfaces, Film.*, vol. 18, no. 2, pp. 299–305, Mar. 2000, doi: 10.1116/1.582183.
- [167] H. U. Poll, C. Winkler, D. Margreiter, V. Grill, and T. D. Märk, "Discrimination effects for ions with high initial kinetic energy in a Nier-type ion source and partial and total electron ionization cross-sections of CF₄," *Int. J. Mass Spectrom. Ion Process.*, vol. 112, no. 1, pp. 1–17, Jan. 1992, doi: 10.1016/0168-1176(92)87029-E.
- [168] R. J. Van Brunt, G. M. Lawrence, L. J. Kieffer, and J. M. Slater, "Electron energy dependence of the kinetic energy and angular distributions of O⁺ from dissociative ionization of O₂," *J. Chem. Phys.*, vol. 61, no. 5, pp. 2032–2037, Sep. 1974, doi: 10.1063/1.1682207.
- [169] S. Lazović *et al.*, "Plasma properties in a large-volume, cylindrical and asymmetric radio-frequency capacitively coupled industrial-prototype reactor," *J. Phys. D. Appl. Phys.*, vol. 46, no. 7, p. 075201, Feb. 2013, doi: 10.1088/0022-3727/46/7/075201.
- [170] S. Živković, N. Puač, Z. Giba, D. Grubišić, and Z. L. Petrović, "The stimulatory effect of non-equilibrium (low temperature) air plasma pretreatment on light-induced germination of *Paulownia tomentosa* seeds," *Seed Sci. Technol.*, vol. 32, no. 3, pp. 693–701, 2004, doi: 10.15258/sst.2004.32.3.05.
- [171] N. Puač, Z. L. Petrović, S. Živković, Z. Giba, D. Grubišić, and A. R. Đorđević, "Low-Temperature Plasma Treatment of Dry Empress-Tree Seeds," in *Plasma Processes and Polymers*, Weinheim, FRG: Wiley-VCH Verlag GmbH & Co. KGaA, 2005, pp. 193–203.
- [172] C. Bailly, H. El-Maarouf-Bouteau, and F. Corbineau, "From intracellular signaling networks to cell death: the dual role of reactive oxygen species in seed physiology," *Comptes Rendus - Biol.*, vol. 331, no. 10, pp. 806–814, 2008, doi: 10.1016/j.crv.2008.07.022.
- [173] L. Rajjou and I. Debeaujon, "Seed longevity: Survival and maintenance of high germination ability of dry seeds," *Comptes Rendus - Biol.*, vol. 331, no. 10, pp. 796–805, 2008, doi: 10.1016/j.crv.2008.07.021.
- [174] J. G. Scandalios, G. Lingqiang, and A. N. Polidoros, *Catalases in plants: gene structure, properties, regulation, and expression*. Cold Spring Harbor Laboratory Press, 1997.
- [175] A. Cerempei, "Aromatherapeutic Textiles," in *Active Ingredients from Aromatic and Medicinal Plants*, vol. 853, InTech, 2017, pp. 439–446.
- [176] D. Grubišić, M. Nešković, and R. Konjević, "Changes in light sensitivity of *Paulownia*

tomentosa and *P. fortunei* seeds,” *Plant Sci.*, vol. 39, no. 1, pp. 13–16, May 1985, doi: 10.1016/0168-9452(85)90185-2.

- [177] D. Grubišić, Z. Giba, and R. Konjević, “The Effect of Organic Nitrates in Phytochrome-Controlled Germination of *Paulownia tomentosa* Seeds,” *Photochem. Photobiol.*, vol. 56, no. 5, pp. 629–632, Nov. 1992, doi: 10.1111/j.1751-1097.1992.tb02213.x.
- [178] H. Nonogaki, G. W. Bassel, and J. D. Bewley, “Germination—still a mystery,” *Plant Sci.*, vol. 179, no. 6, pp. 574–581, 2010, doi: 10.1016/j.plantsci.2010.02.010.
- [179] J. D. Bewley, K. J. Bradford, H. W. M. Hilhorst, and H. Nonogaki, *Seeds*, vol. 9781461446. New York, NY: Springer New York, 2013.
- [180] K. Apel and H. Hirt, “Reactive Oxygen Species: Metabolism, Oxidative Stress, and Signal Transduction,” *Annu. Rev. Plant Biol.*, vol. 55, no. 1, pp. 373–399, Jun. 2004, doi: 10.1146/annurev.arplant.55.031903.141701.
- [181] C. Bailly, A. Benamar, F. Corbineau, and D. Côme, “Free radical scavenging as affected by accelerated ageing and subsequent priming in sunflower seeds,” *Physiol. Plant.*, vol. 104, no. 4, pp. 646–652, Dec. 1998, doi: 10.1034/j.1399-3054.1998.1040418.x.
- [182] A. Vesel, I. Junkar, U. Cvelbar, J. Kovac, and M. Mozetic, “Surface modification of polyester by oxygen- and nitrogen-plasma treatment,” *Surf. Interface Anal.*, vol. 40, no. 11, pp. 1444–1453, Nov. 2008, doi: 10.1002/sia.2923.
- [183] S. Li, H. Boyter, and L. Qian, “UV curing for encapsulated aroma finish on cotton,” *J. Text. Inst.*, vol. 96, no. 6, pp. 407–411, Dec. 2005, doi: 10.1533/joti.2005.0116.
- [184] B. Golja, B. Šumiga, and P. Forte Tavčer, “Fragrant finishing of cotton with microcapsules: comparison between printing and impregnation,” *Color. Technol.*, vol. 129, no. 5, pp. 338–346, Oct. 2013, doi: 10.1111/cote.12044.
- [185] J. R. Roberts, J. K. Olthoff, R. J. Van Brunt, and J. R. Whetstone, “Measurements on the NIST GEC Reference Cell,” in *Advanced Techniques for Integrated Circuit Processing*, Mar. 1991, vol. 1392, pp. 428–436, doi: 10.1117/12.48936.
- [186] M. A. Sobolewski and J. R. Whetstone, “Electrical measurements for monitoring and control of ifplasma processing M. A. Sobolewski and J.R. Whetstone National,” Apr. 1993, vol. 1803, pp. 309–320, doi: 10.1117/12.142926.
- [187] P. Belenguer, P. Guillot, and L. Therese, “Electrical characterization of radiofrequency glow discharge used for optical emission spectroscopy,” *Surf. Interface Anal.*, vol. 35, no. 7, pp. 604–610, 2003, doi: 10.1002/sia.1581.
- [188] R. W. Pearse and A. G. Gaydon, *The Identification of Molecular Spectra*, Fourth ed. London: Chapman and Hall Ltd, 1976.
- [189] A. Lofthus and P. H. Krupenie, “The spectrum of molecular nitrogen,” *J. Phys. Chem. Ref. Data*, vol. 6, no. 1, pp. 113–307, Jan. 1977, doi: 10.1063/1.555546.
- [190] Y. Deslandes, G. Pleizier, E. Poire, S. Sapiha, M. R. Wertheimer, and E. Sacher, “The Surface Modification of Pure Cellulose Paper Induced by Low-Pressure Nitrogen Plasma Treatment,” 1998.
- [191] M. Gorjanc *et al.*, “Plasma treated polyethylene terephthalate for increased embedment of UV-responsive microcapsules,” *Appl. Surf. Sci.*, vol. 419, pp. 224–234, 2017, doi: 10.1016/j.apsusc.2017.04.177.
- [192] T. Vatuša, P. Špatenka, J. Píchal, J. Koller, L. Aubrecht, and J. Wiener, “PES fabric plasma

modification,” *Czechoslov. J. Phys.*, vol. 54, no. S3, pp. C475–C482, Mar. 2004, doi: 10.1007/BF03166441.

- [193] M. D. Teli, K. K. Samanta, P. Pandit, S. Basak, and S. K. Chattopadhyay, “Low-temperature dyeing of silk fabric using atmospheric pressure helium/nitrogen plasma,” *Fibers Polym.*, vol. 16, no. 11, pp. 2375–2383, Nov. 2015, doi: 10.1007/s12221-015-5166-4.
- [194] A. Vesel, M. Mozetic, S. Strnad, Z. Peršin, K. Stana-Kleinschek, and N. Hauptman, “Plasma modification of viscose textile,” *Vacuum*, vol. 84, no. 1, pp. 79–82, 2009, doi: 10.1016/j.vacuum.2009.04.028.
- [195] R. Molina, P. Jovančić, F. Comelles, E. Bertran, and P. Erra, “Shrink-resistance and wetting properties of keratin fibres treated by glow discharge,” *J. Adhes. Sci. Technol.*, vol. 16, no. 11, pp. 1469–1485, Jan. 2002, doi: 10.1163/156856102320252903.
- [196] S. Shahidi, N. Aslan, M. Ghoranneviss, and M. Korachi, “Effect of thymol on the antibacterial efficiency of plasma-treated cotton fabric,” *Cellulose*, vol. 21, no. 3, pp. 1933–1943, 2014, doi: 10.1007/s10570-014-0250-2.
- [197] D. B. Graves and D. Humbird, “Surface chemistry associated with plasma etching processes,” *Appl. Surf. Sci.*, vol. 192, no. 1–4, pp. 72–87, May 2002, doi: 10.1016/S0169-4332(02)00021-1.
- [198] V. Krishnamurthy and I. L. Kamel, “Argon plasma treatment of glass surfaces,” *J. Mater. Sci.*, vol. 24, no. 9, pp. 3345–3352, Sep. 1989, doi: 10.1007/BF01139063.
- [199] R. Barni, C. Riccardi, and M. Fontanesi, “Experimental study of outgassing from textile materials,” *J. Vac. Sci. Technol. A Vacuum, Surfaces, Film.*, vol. 21, no. 3, pp. 683–689, 2003, doi: 10.1116/1.1568347.
- [200] V. A. Godyak and R. B. Piejak, “Abnormally low electron energy and heating-mode transition in a low-pressure argon rf discharge at 13.56 MHz,” *Phys. Rev. Lett.*, vol. 65, no. 8, pp. 996–999, Aug. 1990, doi: 10.1103/PhysRevLett.65.996.
- [201] V. A. Godyak, R. B. Piejak, and B. M. Alexandrovich, “Measurement of electron energy distribution in low-pressure RF discharges,” *Plasma Sources Sci. Technol.*, vol. 1, no. 1, pp. 36–58, Mar. 1992, doi: 10.1088/0963-0252/1/1/006.
- [202] M. Dimitrova *et al.*, “Radial profile of the electron energy distribution function in RF capacitive gas-discharge plasma,” *J. Phys. Conf. Ser.*, vol. 700, no. 1, p. 012007, Mar. 2016, doi: 10.1088/1742-6596/700/1/012007.
- [203] C.-E. Zhou and C. Kan, “Plasma-assisted regenerable chitosan antimicrobial finishing for cotton,” *Cellulose*, vol. 21, no. 4, pp. 2951–2962, Aug. 2014, doi: 10.1007/s10570-014-0266-7.
- [204] C.-W. Kan, “Using Plasma Treatment for Enhancing the Coating for Rechargeable Antimicrobial Finishing of Cotton Fabric,” *Int. J. Chem. Eng. Appl.*, vol. 6, no. 6, pp. 432–435, Dec. 2015, doi: 10.7763/IJCEA.2015.V6.524.
- [205] A. Rashidi, S. Shahidi, M. Ghoranneviss, S. Dalalsharifi, and J. Wiener, “Effect of Plasma on the Zeta Potential of Cotton Fabrics,” *Plasma Sci. Technol.*, vol. 15, no. 5, pp. 455–458, May 2013, doi: 10.1088/1009-0630/15/5/12.
- [206] N. Abidi and E. Hequet, “Cotton fabric graft copolymerization using microwave plasma. I. Universal attenuated total reflectance-FTIR study,” *J. Appl. Polym. Sci.*, vol. 93, no. 1, pp. 145–154, Jul. 2004, doi: 10.1002/app.20442.
- [207] U. Cvelbar, M. Mozetič, and A. Ricard, “Characterization of oxygen plasma with a fiber

optic catalytic probe and determination of recombination coefficients,” *IEEE Trans. Plasma Sci.*, vol. 33, no. 2 II, pp. 834–837, 2005, doi: 10.1109/TPS.2005.845286.

- [208] A. Kamenetskikh, N. Gavrilov, S. Krivoshapko, and P. Tretnikov, “Application of the catalytic probe method for measuring the concentration of oxygen atoms in Ar/O₂ plasma of a low-pressure arc,” *Plasma Sources Sci. Technol.*, vol. 30, no. 1, 2021, doi: 10.1088/1361-6595/abd0df.
- [209] I. Šorli and R. Ročak, “Determination of atomic oxygen density with a nickel catalytic probe,” *J. Vac. Sci. Technol. A Vacuum, Surfaces, Film.*, vol. 18, no. 2, pp. 338–342, 2000, doi: 10.1116/1.582189.
- [210] M. Mozetic, A. Vesel, U. Cvelbar, and A. Ricard, “An iron catalytic probe for determination of the o-atom density in an Ar/O₂ afterglow,” *Plasma Chemistry and Plasma Processing*, vol. 26, no. 2, pp. 103–117, 2006, doi: 10.1007/s11090-006-9004-8.
- [211] M. Mozetič, A. Vesel, M. Gaillard, and A. Ricard, “Atomic oxygen concentration in a flowing post-discharge reactor,” *Plasmas Polym.*, vol. 6, no. 1–2, pp. 71–79, 2001, doi: 10.1023/A:1011305020613.
- [212] N. Vázquez-Mera, C. Roscini, J. Hernando, and D. Ruiz-Molina, “Liquid-Filled Capsules as Fast Responsive Photochromic Materials,” *Adv. Opt. Mater.*, vol. 1, no. 9, pp. 631–636, Sep. 2013, doi: 10.1002/adom.201300121.
- [213] Y. Zhou, Y. Yan, Y. Du, J. Chen, X. Hou, and J. Meng, “Preparation and application of melamine-formaldehyde photochromic microcapsules,” *Sensors Actuators, B Chem.*, vol. 188, pp. 502–512, 2013, doi: 10.1016/j.snb.2013.07.049.
- [214] R. Alagirusamy, B. Gupta, B. Deopura, and M. Joshi, Eds., *Polyesters and polyamides*. Boca Raton: CRC Press, 2008.
- [215] J. Lv, Q. Zhou, T. Zhi, D. Gao, and C. Wang, “Environmentally friendly surface modification of polyethylene terephthalate (PET) fabric by low-temperature oxygen plasma and carboxymethyl chitosan,” *J. Clean. Prod.*, vol. 118, pp. 187–196, Apr. 2016, doi: 10.1016/j.jclepro.2016.01.058.
- [216] I. Junkar, M. Modic, and M. Mozeti, “Modification of PET surface properties using extremely non-equilibrium oxygen plasma,” *Open Chem.*, vol. 13, no. 1, pp. 490–496, Jan. 2014, doi: 10.1515/chem-2015-0061.
- [217] T. Salem, D. Pleul, M. Nitschke, M. Müller, and F. Simon, “Different plasma-based strategies to improve the interaction of anionic dyes with polyester fabrics surface,” *Appl. Surf. Sci.*, vol. 264, pp. 286–296, Jan. 2013, doi: 10.1016/j.apsusc.2012.10.014.
- [218] J. Casimiro *et al.*, “Introduction of Primary Amino Groups on Poly(ethylene terephthalate) Surfaces by Ammonia and a Mix of Nitrogen and Hydrogen Plasma,” *Plasma Chem. Plasma Process.*, vol. 32, no. 2, pp. 305–323, Apr. 2012, doi: 10.1007/s11090-011-9345-9.

PRILOZI

Биографија аутора

Коста Спасић је рођен 11.08.1984. године у Београду. Основне академске студије, смер Примењена физика и информатика, завршио је 2010. године на Физичком факултету Универзитета у Београду са просечном оценом 8,26. Дипломски рад под називом „Активација Лангмуирове сонде и мерење концентрације електрона и јона у нискотемпературним плазмама у аргону“ урадио је у лабораторији за Гасну електронику (данас је њено име Лабораторија за неравнотежне процесе и примену плазме) Института за физику у Београду под менторством Др Невене Пуач.

Докторске студије уписао је 2011. године на Физичком факултету Универзитета у Београду, смер – Физика јонизованог гаса и плазме. Положио је све изборне испите са просечном оценом 10.00. Тему докторске дисертације под називом „Дијагностика асиметричног и план паралелног радио-фреквентног система у циљу дефинисања плазма хемијских процеса током третмана узорака органског и неорганског порекла“ одбранио је пред колегијумом на седници Наставно-научног већа Физичког факултета на седници која је одржана 24.10.2018. године. Извештај комисије за оцену испуњености услова и оправданост предложене теме је усвојен на седници Наставно-научног већа Физичког факултета која је одржана 27.3.2019. године и том приликом је прихваћен и предлог да се за ментора који ће да руководи израдом дисертације постави Др Невена Пуач.

Од 1. јануара 2011. године је запослен у Институту за физику у Београду у оквиру Лабораторије за неравнотежне процесе и примену плазми. До децембра 2019. године је учествовао на иновационом пројекту Министарства за просвету, науку и технолошки развој Републике Србије „Примене нискотемпературних плазми у биомедицини, заштити човекове околине и нанотехнологијама“ (ИИИ41011) као и на пројекту основних истраживања „Фундаментални процеси и примене транспорта честица у неравнотежним плазмама, траповима и наноструктурама“ (ОН171037). Од 2020. године на институту је ангажован институционално. Учествовао је и на неколико билатералних пројеката а резултати ових сарадњи су представљени и у оквиру докторске дисертације.

Његова област истраживања је плазма физика. Према SCOPUS бази података, резултате свог рада је приказао у 8 радова, који су према истој бази цитирани 63 пута. Био је коаутор на неколико међународних предавања по позиву а своје резултате је представио и на већем броју конференција.

Изјава о ауторству

Име и презиме аутора _____ Коста Спасић _____

Број индекса _____ 8022/2018 _____

Изјављујем

да је докторска дисертација под насловом

Дијагностика асиметричног и план паралелног радио-фреквентног система у циљу дефинисања плазма хемијских процеса током третмана узорака органског и неорганског порекла

- резултат сопственог истраживачког рада;
- да дисертација у целини ни у деловима није била предложена за стицање друге дипломе према студијским програмима других високошколских установа;
- да су резултати коректно наведени и
- да нисам кршио/ла ауторска права и користио/ла интелектуалну својину других лица.

Потпис аутора

У Београду, _____

Изјава о истоветности штампане и електронске верзије докторског рада

Име и презиме аутора Коста Спасић

Број индекса 8022/2018

Студијски програм Физика јонизованог гаса и плазме

Наслов рада Дијагностика асиметричног и план паралелног радио-
фреквентног система у циљу дефинисања плазма хемијских процеса током третмана узорака
органиског и неорганиског порекла

Ментор др Невена Пуач

Изјављујем да је штампана верзија мог докторског рада истоветна електронској верзији коју сам предао/ла ради похрањивања у **Дигиталном репозиторијуму Универзитета у Београду**.

Дозвољавам да се објаве моји лични подаци везани за добијање академског назива доктора наука, као што су име и презиме, година и место рођења и датум одбране рада.

Ови лични подаци могу се објавити на мрежним страницама дигиталне библиотеке, у електронском каталогу и у публикацијама Универзитета у Београду.

Потпис аутора

У Београду, _____

Изјава о коришћењу

Овлашћујем Универзитетску библиотеку „Светозар Марковић“ да у Дигитални репозиторијум Универзитета у Београду унесе моју докторску дисертацију под насловом:

„Дијагностика асиметричног и план паралелног радио-фреквентног система у циљу дефинисања плазма хемијских процеса током третмана узорака органског и неорганског порекла“ која је моје ауторско дело.

Дисертацију са свим прилозима предао/ла сам у електронском формату погодном за трајно архивирање.

Моју докторску дисертацију похрањену у Дигиталном репозиторијуму Универзитета у Београду и доступну у отвореном приступу могу да користе сви који поштују одредбе садржане у одабраном типу лиценце Креативне заједнице (Creative Commons) за коју сам се одлучио/ла.

1. Ауторство (CC BY)
2. Ауторство – некомерцијално (CC BY-NC)
3. Ауторство – некомерцијално – без прерада (CC BY-NC-ND)
4. Ауторство – некомерцијално – делити под истим условима (CC BY-NC-SA)
5. Ауторство – без прерада (CC BY-ND)
6. Ауторство – делити под истим условима (CC BY-SA)

(Молимо да заокружите само једну од шест понуђених лиценци.
Кратак опис лиценци је саставни део ове изјаве).

Потпис аутора

У Београду, _____

1. **Ауторство.** Дозвољаваате умножавање, дистрибуцију и јавно саопштавање дела, и прераде, ако се наведе име аутора на начин одређен од стране аутора или даваоца лиценце, чак и у комерцијалне сврхе. Ово је најслободнија од свих лиценци.
2. **Ауторство – некомерцијално.** Дозвољаваате умножавање, дистрибуцију и јавно саопштавање дела, и прераде, ако се наведе име аутора на начин одређен од стране аутора или даваоца лиценце. Ова лиценца не дозвољава комерцијалну употребу дела.
3. **Ауторство – некомерцијално – без прерада.** Дозвољаваате умножавање, дистрибуцију и јавно саопштавање дела, без промена, преобликовања или употребе дела у свом делу, ако се наведе име аутора на начин одређен од стране аутора или даваоца лиценце. Ова лиценца не дозвољава комерцијалну употребу дела. У односу на све остале лиценце, овом лиценцом се ограничава највећи обим права коришћења дела.
4. **Ауторство – некомерцијално – делити под истим условима.** Дозвољаваате умножавање, дистрибуцију и јавно саопштавање дела, и прераде, ако се наведе име аутора на начин одређен од стране аутора или даваоца лиценце и ако се прерада дистрибуира под истом или сличном лиценцом. Ова лиценца не дозвољава комерцијалну употребу дела и прерада.
5. **Ауторство – без прерада.** Дозвољаваате умножавање, дистрибуцију и јавно саопштавање дела, без промена, преобликовања или употребе дела у свом делу, ако се наведе име аутора на начин одређен од стране аутора или даваоца лиценце. Ова лиценца дозвољава комерцијалну употребу дела.
6. **Ауторство – делити под истим условима.** Дозвољаваате умножавање, дистрибуцију и јавно саопштавање дела, и прераде, ако се наведе име аутора на начин одређен од стране аутора или даваоца лиценце и ако се прерада дистрибуира под истом или сличном лиценцом. Ова лиценца дозвољава комерцијалну употребу дела и прерада.

Слична је софтверским лиценцама, односно лиценцама отвореног кода.



УНИВЕРЗИТЕТ У БЕОГРАДУ
ФИЗИЧКИ ФАКУЛТЕТ

Бр. 4111
7. 6. 2022
БЕОГРАД СТУДЕНТСКИ ТРГ 12-9
ФИ ФАК 04

На основу члана 29 Закона о општем управном поступку («Службени гласник РС» број 18/2016 и 95/2018), и члана 149 Статута Универзитета у Београду - Физичког факултета, по захтеву КОСТЕ СПАСИЋА, мастер физичара, издаје се следеће

У В Е Р Е Њ Е

КОСТА СПАСИЋ, мастер физичар, дана 3. јуна 2022. године, одбранио је докторску дисертацију под називом

„ДИЈАГНОСТИКА АСИМЕТРИЧНОГ И ПЛАН ПАРАЛЕЛНОГ РАДИО-ФРЕКВЕНТНОГ ПЛАЗМА СИСТЕМА У ЦИЉУ ДЕФИНИСАЊА ПЛАЗМА ХЕМИЈСКИХ ПРОЦЕСА ТОКОМ ТРЕТМАНА УЗОРАКА ОРГАНСКОГ И НЕОРГАНСКОГ ПОРЕКЛА“

пред Комисијом Универзитета у Београду - Физичког факултета и тиме испунио све услове за промоцију у ДОКТОРА НАУКА – ФИЗИЧКЕ НАУКЕ.

Уверење се издаје на лични захтев, а служи ради регулисања права из радног односа и важи до промоције, односно добијања докторске дипломе.

Уверење је ослобођено плаћања таксе.



ДЕКАН ФИЗИЧКОГ ФАКУЛТЕТА

Проф. др Иван Белча