

ИНСТИТУТ ЗА ФИЗИКУ

НАУЧНОМ ВЕЋУ
ИНСТИТУТА ЗА ФИЗИКУ
У БЕОГРАДУ

ПРИМЉЕНО:			
Рад.јед.	б р о ј	Арх.шифра	Прилог

Предмет: Молба за покретање поступка за избор у звање виши научни сарадник

МОЛБА

С обзиром да испуњавам критеријуме прописане од Министарства просвете, науке и технолошког развоја за избор у звање виши научни сарадник, молим Научно веће Института за физику у Београду да покрене поступак за мој избор у наведено звање.

У прилогу достављам:

1. Мишљење руководиоца пројекта са предлогом чланова комисије за избор у звање;
2. Стручну биографију;
3. Преглед научне активности;
4. Елементе за квалитативну оцену научног доприноса;
5. Елементе за квантитативну оцену научног доприноса;
6. Списак објављених научних радова и фотокопије радова објављених након претходног избора у звање;
7. Податке о цитираности;
8. Решење о претходном избору у звање.
9. Доказе о испуњености наведених квалитативних услова

У Београду,

19.04.2022.

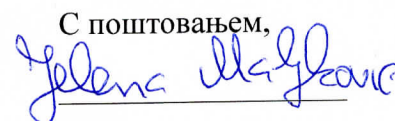
С поштовањем,

Јелена Маљковић

ИНСТИТУТ ЗА ФИЗИКУ

ПРИМЉЕНО:		19. 04. 2022	
Рад.јед.	б р о ј	Арх.шифра	Прилог
ФФФ	441/2		

НАУЧНОМ ВЕЋУ
ИНСТИТУТА ЗА ФИЗИКУ
У БЕОГРАДУ

Предмет: Мишљење руководиоца за избор др Јелене Маљковић у звање виши научни сарадник

Др Јелена Маљковић запослена је у Лабораторији за атомске сударне процесе Института за физику у Београду. У претходном периоду била је ангажована на пројектима основних истраживања Министарства просвете, науке и технолошког развоја као и на неколико међународних пројеката у оквиру којих је учествовала у експерименталним истраживањима интеракције електрона са биомолекулима, анестетицима, органометалицима као и интеракцији електрона са нанокапикларима.

С обзиром да испуњава све критеријуме прописане Правилником о поступку, начину вредновања и квантитативном исказивању научноистраживачких резултата Министарства просвете, науке и технолошког развоја, сагласан сам са покретањем поступка за избор др Јелене Маљковић у звање виши научни сарадник.

Предлажем да комисију за избор др Јелене Маљковић у звање виши научни сарадник чине:

1. др Ненад Симоновић, научни саветник, Институт за физику у Београду,
2. др Владимир Срећковић, научни саветник, Институт за физику у Београду,
3. др Братислав Маринковић, научни саветник у пензији, Институт за физику у Београду и
4. проф. др Горан Попарић, редовни професор, Физички факултет, Универзитет у Београду

У Београду,
19. 04. 2022

Руководилац лабораторије,
N. Simonović

Др Ненад Симоновић

научни саветник

Институт за физику у Београду

1. Биографски подаци

Јелена (Божидара) Маљковић је рођена у Травнику (Босна и Херцеговина) 24.04.1977. године. Физички факултет, смер Теоријска и експериментална физика, је завршила 2006. године на Универзитету у Београду са средњом оценом 8.82. Мастер студије је уписала 2006. године на Физичком факултету универзитета у Београду и завршила 2007. године са просечном оценом 10.00. Докторске студије је уписала 2007. године на Физичком факултету Универзитета у Београду – смер Експериментална физика атома и молекула и завршила са средњом оценом 10.00.

Јелена Маљковић је добитник Норвешке стипендије 2001. године. У радном односу на Институту за физику Универзитета у Београду је од јуна 2008. године.

Учешће на националним пројектима:

2011-2019 "Физика судара и фотопроцеса у атомским, (био)молекулским и нанодимензионим системима" **No OI 171020**

2006 - 2010 "Electron and laser spectrometry and collisional cross sections for atoms, ions, molecules, metastables and biomolecules" Министарство Науке и Технолошког Развоја, Република Србија, **No.141011;**

Учешће на билатералним пројектима:

2016 - 2018 Република Србија – Италија, Research projects of particular relevance (Grande Rilevanza) selected within the frame of the executive programme of scientific and technological cooperation between Italian Republic and Republic of Serbia – Research area: Mathematics, Physics, Chemistry and Biology: "A nanoview of radiation-biomatter interaction"

2013 - 2015 Билатерална сарања, Српска Академија Наука и Уметности и Мађарска Академија Наука: "Interactions of charge particles with single insulating capillaries"

2012 - 2013 “Photon and electron spectroscopy of pure and nano-solvated biomolecules isolated in gas phase” Република Србија - Француска, Програм “Павле Савић” # 680-00-132/2012-09/06

2010 - 2012 “Excitation and fragmentation of small biomolecules”, Република Србија – Словачка, Билатерална сарадња No. SKSRB-0011-09.

2008 - 2009 “Electron induced fragmentation of organic molecules and small hydrocarbons”, Република Србија–Словенија, Билатерална сарадња

У оквиру ових пројеката Јелена Маљковић је значајно проширила своје знање и искуство током научних посета Институту Јожеф Штефан у Љубљани, Comenius Универзитета у Братислави, SOLEIL синхротрону поред Париза, Института Атомки у Мађарској.

Учешће на интернационалним пројектима:

- Јелена Маљковић је била члан менаџмент комитета COST акције CM1301 “Chemistry for Electron-Induced Nanofabrication (CELINA)” CSO Start of Action: 23/10/2013, End of Action: 23/10/2017.
- Кандидаткиња је учесник COST акције CA18212 “Molecular Dynamics in the GAS phase”, Start of Action - 12/11/2019 End of Action - 11/11/2023
- Кандидаткиња је учесник COST акције CA20129 “Multiscale Irradiation and Chemistry Driven Processes and Related Technologies” Start of Action - 04/10/2021 End of Action - 03/10/2025

У оквиру националног пројекта ОИ171020, Физика судара и фотопроцеса у атомским, (био)молекулским и нанодимензионим системима, др Јелена Маљковић је руководилац пројектним задатком: Проучавање електронске интеракције са биомолекулима, анестетицима и наночестицама.

Јелена Маљковић је била руководилац мастер рада Јелене Вуковић а сад је руководилац докторске тезе кандидаткиње.

2. Преглед научне активности др Јелене Маљковић

Научна активност др Јелене Маљковић везана је за област атомске, молекулске и хемијске физике. Експериментална истраживања кандидаткиње се могу поделити у следеће подтеме:

- 1) мерење апсолутних диференцијалних пресека за еластично расејање електрона средњих енергија (40-300eV) на: биомолекулима, анестетицима и племенитим гасовима
- 2) трансмисију електрона средњих енергија кроз металне капиларе.
- 3) процесе дисоцијативног електронског захвата и дисоцијативне јонизације на органометалицима.

Напомена: Звездицом () су означени радови објављени након предходног избора у звање.*

2.1 Мерење апсолутних диференцијалних пресека

Истраживање интеракција електрона са молекулима под добро дефинисаним експерименталним условима има за циљ да се прошири знање о молекулским процесима (разумевање структуре и динамике молекулских система) како би се исти могли карактеризовати у теоријским прорачунима. Налажење вероватноће, тј. диференцијалног пресека је од пресудног значаја за опис сударног процеса и у експерименталним и у теоријским истраживањима. Експериментално одређивање диференцијалног пресека заснива се на мерењу интензитета, тј. броја расејаних електрона у функцији угла или енергије при чему између мереног сигнала и траженог пресека постоји директна зависност. У оквиру истраживања електронских сударних процеса били су одређивани релативни и апсолутни диференцијални пресеци за еластично расејање електрона средњих енергија, од 40-300eV на биомолекулима (аналогним неким деловима ДНК), анестетицима, метану и аргону. Сва мерења су извршена у режиму бинарних судара техником укрштених млазева – електронског млаза произведеног у електронском топу и млаза молекула. Од 2007 године кандидаткиња се бавила проучавањем интеракције електрона средњих енергија са биомолекулима аналогним неким деловима ДНК. Наставак на предходно мерене молекуле који су аналогни неким деловима молекула релевантним за грађу биолошких макромолекула: фуран, 3-хидроксиететрахидрофуран (аналогни дезоксирибози у ДНК), пиримидин (аналоган пиримидинским базама), формаид и н-метилформаид (молекули који садрже пептидну везу), је било мерење релативних и апсолутних диференцијалних пресека за еластично расејање електрона на триетил фосфату (C₂H₅)₃PO₄ који је аналоган фосфатној групи у ДНК. Теоријске прорачуне је радио професор Tökési из Мађарске. Резултати истраживања расејања електрона на молекулима аналогним неким деловима ДНК приказани су у следећим радовима:

(M23*) Jelena B. Maljković, Jelena Vuković, Károly Tökési, Branko Predojević, and Bratislav P. Marinković,

“Elastic electron scattering cross sections for triethyl phosphate molecule at intermediate electron energies from 50 to 250 eV”,

Eur. Phys. J.D **73**, 27 (2019). [5pp] (on-line 5 Feb 2019)

[doi: 10.1140/epjd/e2019-90631-1](https://doi.org/10.1140/epjd/e2019-90631-1)

(M21) J. B. Maljković, F. Blanco, R. Čurik, G. García, B. P. Marinković, and A. R. Milosavljević,

“Absolute cross sections for electron scattering from furan”,

J. Phys. Chem. **137** 064312 (2012) [10 pages].

<http://link.aip.org/link/?JCP/137/064312>

[doi: 10.1063/1.4742759](https://doi.org/10.1063/1.4742759)

(M21) J. B. Maljković, F. Blanco, G. García, B. P. Marinković, and A. R. Milosavljević,

“Absolute cross sections for elastic electron scattering from methylformamide”,

Physical Review A **85**, 042723 (2012) [8 pages].

<http://link.aps.org/doi/10.1103/PhysRevA.85.042723>

[DOI: 10.1103/PhysRevA.85.042723](https://doi.org/10.1103/PhysRevA.85.042723)

(M21) J. B. Maljković, A. R. Milosavljević, F. Blanco, D. Šević, G. García, and B. P. Marinković,

“Absolute differential cross sections for elastic scattering of electrons from pyrimidine”,

Phys. Rev. A **79**, 052706 (2009) [7 pages].

<http://link.aps.org/doi/10.1103/PhysRevA.79.052706>

[doi: 10.1103/PhysRevA.79.052706](https://doi.org/10.1103/PhysRevA.79.052706)

(M22) J. B. Maljković, F. Blanco, G. García, B. P. Marinković, and A. R. Milosavljević,

“Elastic electron scattering from formamide molecule”,

Nucl. Instrum. Meth. B. **279** 124-127 (2012).

[doi:10.1016/j.nimb.2011.10.029](https://doi.org/10.1016/j.nimb.2011.10.029)

(M23) A. R. Milosavljević, F. Blanco, J. B. Maljković, D. Šević, G. García, and B. P. Marinković,

“Absolute cross sections for elastic electron scattering from 3-hydroxytetrahydrofuran”,

New J. Phys. **10** 103005 (2008) [19 pages].

[doi: 10.1088/1367-2630/10/10/103005](https://doi.org/10.1088/1367-2630/10/10/103005)

(M23) B. P. Marinković, A. R. Milosavljević, J. B. Maljković, D. Šević, B. A. Petruševski, D. Pavlović, D. M. Filipović, M. Terzić and V. Pejčev,

“Optical and Electron Spectrometry of Molecules of Biological Interest”,

Acta Physica Polonica A **112**(5) 1143-1148 (2007).

Апсолутни диференцијални пресеци мерени су и на halogenim inhalacionim анестетицима халотену ($C_2HBrClF_3$) и севофлурану ($C_4H_7F_7O$). Фокусирање на упознавање молекулске структуре и хемијских особина халогених анестетика може помоћи у разумевању њихових реактивности и унапређењу у клиничкој употреби. Севофлуран се користи од 1990г а сад је један од најкоришћенијих анестетика у различитим типовима операција као и у дечијој хирургији. Такође, халогени анестетици су битни због њихове улоге у атмосферској хемији, заједно са улогом хлорофлуорокарбона у оштећењу озонског омотача у стратосфери. Инхалациони анестетици се врло мало метаболички мењају при клиничкој употреби, тако да молекули анестетика са дугим временом живота могу стићи у стратосферу у великој количини. Теоријски прорачуни за ова мерења су рађени од стране групе из Шпаније и јако добро имамо слагање експеримента и теорије. Резултати за халотен су приказани на неколико саопштења на међународним конференцијама а публикација рада је току.

Резултати истраживања расејања електрона на молекулима анестетика приказани су у следећим раду и саопштењу са конференције:

(M21*) Jelena Vukalović, Jelena B. Maljković, Francisco Blanco, Gustavo García, Branko Predojević, Bratislav P. Marinković

“Absolute differential cross-sections for elastic electron scattering from sevoflurane molecule in the energy range from 50-300 eV”,

Int. J. Molec. Sci. **23(1)** 21 (2022) [11pp].

[doi: 10.3390/ijms23010021](https://doi.org/10.3390/ijms23010021)

ISSN: 1422-0067

(M33) Jelena B. Maljković, Aleksandar R. Milosavljević, Zoran Pešić, F. Blanco, G. García, Dragutin Šević and Bratislav P. Marinković

“Absolute differential cross section for elastic electron scattering from halothane at 100eV

Proc. 25th Summer School and International Symposium on Physics of Ionized Gases SPIG, 30th Publ. Astron. Obs. Belgrade No. 89, July (2010),

ISSN: 0373-3742 pp. 33 – 36.

Кандидаткиња се бавила и проучавањем метана (CH_4), гаса који у великој мери, доприноси ефекту "стаклене баште". Овај ефекат је око 8 пута већи од CH_4 него од CO_2 . Метан је проучаван:

а) одређивањем апсолутних диференцијалних пресека за еластично расејање електрона на молекулима метана на електронском спектрометру УГРА на Институту за физику у Београду

б) одређивањем енергија појављивања продуката дисоцијације услед ексцитације електронима, приликом посете Comenius факултету у Братислави у оквиру билатералне сарадње.

Резултати истраживања расејања електрона на молекулима метана приказани су у следећим радовима:

(M21*) Jelena Vukalović, Jelena B. Maljković, Karoly Tökési, Branko Predojević, Bratislav P. Marinković,

“Elastic electron scattering from methane molecule in the energy range from 50-300 eV”,

Int. J. Molec. Sci. **22**(2) 647 (2021) [14pp].

Special Issue "Electron and Photon Interactions with Bio(Related) Molecules"

[doi: 10.3390/ijms22020647](https://doi.org/10.3390/ijms22020647)

ISSN: 1422-0067

(M21) M Danko, J Orszagh, M Durian, J Kočiček, M Daxner, S Zöttl, J B Maljković, J Fedor, P Scheier, S Denifl and Š Matejčik

“Electron impact excitation of methane: determination of appearance energies for dissociation products”

J. Phys. B: At. Mol. Opt. Phys **46** 045203 (2013)

[doi: 10.1088/0953-4075/46/4/045203](https://doi.org/10.1088/0953-4075/46/4/045203)

Апсолутни диференцијални пресеци (DCS) за еластично расејање електрона на аргону су такође мерени на електронском спектрометру УГРА. За референтни гас у методи Релативних протока (Relative flow) коришћен је хелијум. Овим резултатима смо добили један конзистентан скуп апсолутних диференцијалних пресека за еластично расејање електрона на аргону за средњи распон уданих енергија (40-300eV) које смо користили као референтне пресеке за мерења апсолутних DCS свих наредних мета.

Из овог мерења публикован је рад:

(M23*) Milos Lj. Rankovic, Jelena B. Maljkovic, Karoly Tokesi, and Bratislav P. Marinkovic,

Elastic electron differential cross sections for argon atom in the intermediate energy range from 40 eV to 300 eV

Eur. Phys. J.D **72**, 30 (2018) [9pp],

[doi: 10.1140/epjd/e2017-80677-4](https://doi.org/10.1140/epjd/e2017-80677-4)

ISSN: 1434-6060

У циљу добијања поузданих вредности пресека било је потребно развити методологију мерења и унапредити низ експерименталних техника у електронској спектрометрији. У оквиру ове тематике Јелена Маљковић је радила на:

- унапређењу гасног система апаратуре УГРА у циљу омогућавања мерења апсолутних диференцијалних пресека, *Relative flow method*. Суштина овог метода је упоредно мерење сигнала расејаних електрона за непознатом и такозваном

референтном гасу, уз додатно мерење брзине протока сваког гаса и пажљиво подешавање апсолутних притисака.

- калибрацији и тестирању експерименталног уређаја;
- методологији мерења релативних пресека и добијању апсолутних вредности диференцијалних пресека.

Енергијски разложене структуре у спектрима губитака енергије директно описује процесе ексцитације молекула. Разумевање ових структура и свеукупне интеракције електрона са органским молекулима, обезбеђује основу за разумевање како структуре тако и динамике ових система. Иако је поставка апаратуре на којој су рађена истраживања пре свега оптимизована за мерење релативних и апсолутних диференцијалних пресека за еластично расејање електрона и не дозвољава мерење спектра губитака енергије са веома високом енергијском резолуцијом, добијени спектри су од значаја за проверу чистоће мете, као и за подршку оптичким спектрима при анализи података добијених мерењима на синхротрону са ултра-високом резолуцијом.

Резултати до којих је дошла кандидаткиња у оквиру ове тематике упоређени су са теоријским прорачунима, што је омогућило тестирање и унапређење теоријских модела и метода за одређивање апсолутних пресека за еластично расејање електрона средњих енергија на релативно великим молекулима. Добијени су вредни резултати како за фундаментално разумевање процеса интеракције елементарних честица са комплексним молекулским системима, тако и за мултидисциплинарна истраживања која могу имати важну примену у биомедицинским наукама.

2.2 Интеракција електрона са металним капиларама

Разумевање и интерпретација спектра електрона расејаних на чврстим површинама је битно за многе техничке апликације. За карактеризацију површина и дијагностику којом се избегава оштећење материјала и модификација површине као и разумевању самих процеса расејања. На експерименту УГРА кандидаткиња се бавила проучавањем трансмисије електрона кроз макроскопске металне капиларе, након вишеструких судара са зидовима мете. Јасно је да је експериментално немогуће одредити разлику између трансмитованих примарних и секундарних електрона генерисаних у нееластичним сударима са зидовима капиларе и захтева додатне симулације трансмисије.

У колаборацији са колегама из Мађарске и Винче, који су били задужени за симулације, кандидаткиња је објавила два рада.:

(M22) J.B. Maljković, D. Borka, M. Lj. Ranković, B.P. Marinković,
A.R. Milosavljević, C. Lemell, and K. Tőkési*

“Electron transmission through a steel capillary”, *Nucl. Instrum. Meth. B*, **423**, 87–91 (2018).

[doi: 10.1016/j.nimb.2018.03.020](https://doi.org/10.1016/j.nimb.2018.03.020)

(M21*) *A. R. Milosavljević, M. Lj. Ranković, D. Borka, J. B. Maljković, R. J. Berezsky, B. P. Marinković and K. Tőkési*

“Study of electron transmission through a platinum tube”,
Nucl. Instrum. Meth. B **354**, 86-89 (2015). [on-line 15 Dec 2014]
[doi: 10.1016/j.nimb.2014.11.087](https://doi.org/10.1016/j.nimb.2014.11.087)
ISSN: 0168-583X

2.3 Интеракција електрона са органометалицима

FEBID (Focused Electron Beam Induced Deposition) је врло обећавајућа техника депозиције за нанофабрикацију, која производи 3Д структуре од суб-10nm димензија. Велики број органометалика произведених специјално за CVD (Chemical Vapour Deposition), FEBID користи за своје прекурсоре, за производњу 3Д металних наноструктура. FEBID је техника у којој се високоенергијски фокусирани сноп усмери на перкурсор доводећи до дисоцијације и у идеалном случају водећи ка стварању депозита.. Наиме, високоенергијски сноп ствара мноштво секундарних електрона са енергијом испод 100 eV који доводе до фрагментације прекурсора коз различите процесе декомпозиције, као што су дисоцијативна јонизација, диполарна дисоцијација, неутрална дисоцијација и процес дисоцијативног електронског захвата (DEA). У оквиру ове тематике, а у сарадњи са колегама из Словачке и Пољске, кандидаткиња је проучавала процесе дисоцијативне јонизације за tetraethyl ortosilicate (TEOS) као и процес дисоцијативног електронског захвата за TEOS и benzene chromium tricarbonyl molekule. Обе мете се могу сматрати потенцијалним FEBID прекурсорима. Мерења на TEOS молекулу су извођена на две независне експерименталне поставке на, Cross Beam (CBA) и Cluster Aparateus (CA), на Comenius факултету у Братислави. Обе експерименталне поставке поседују Trohoidal Electron Monochromator (TEM) и Quadropol Mass Analyzer (QMA). Обе апаратуре користе метод укрштених млазева, млаз електрона се у интеракционој запремини под углом од 90° судара са млазом молекула мете. Након што се у интеракционој запремини формирају позитивни јони, они се масено анализирају у QMA и детектују. Након налажења масеног спектра за TEOS молекул прагови енергије за стварање сваког позивног фрагмента су мерени. Током кандидаткињиног боравка у Пољској процес дисоцијативног електронског захвата на benzene chromium tricarbonyl молекулу је проучаван. Овај ораганометалик је такође потенцијални FEBID прекурсор. Такође експеримент је базиран на методи укрштених млазева, са TEM-ом, QMA и детектором, смештеним у вакумску комору. Мерења су рађена у функцији енергије упадних електрона од 0-12e V. У овом енергијском распону процес дисоцијативног електронског захвата је заслужан за фрагментацију молекула. Молекул је показао врло богато формирање анјона. У оквиру потенцијалне улоге хромијумивих јединјена у FEBID-у, показано је да је DEA процесима могуће уклонити и бензен и све CO групе и формирати [Cr]⁻. Кандидаткиња је током боравка од три недеље у Пољској, у

оквиру научне посете COST акције CELINA, radila на мерењима везаним за DEA процесе на овом молекулу.

Ове резултате кандидаткиња је представила на CELINA састанцима у Братислави и Кракову и објављен је рад :

(M21*) *Janina Kopyra, Paulina Maciejewska and Jelena Maljković*

“Dissociative electron attachment to coordination complexes of chromium: chromium(0) hexacarbonyl and benzene-chromium(0) tricarbonyl”,
Beilstein J. Nanotechnol. **8**, 2257–2263 (2017).

[doi: 10.3762/bjnano.8.225](https://doi.org/10.3762/bjnano.8.225)

ISSN: 2190-4286

(M32*) *Jelena Maljković, Paulina Maciejewska and Janina Kopyra,*

“Dissociative electron attachment to benzene chromium tricarbonyl”
Proc. The 3rd CELINA Meeting, Kraków, May 18-20, 2016, Eds. Petra Swiderek and Janina Kopyra, p.20

<http://celina.uni-bremen.de/celina/celina2016/index.php?id=start&lang=en>

(M32*) *Jelena Maljković, Peter Papp, Michal Lacko, Michal Stano, Aleksandar Milosavljević, Stefan Matejčík*

“Electron impact dissociative ionization of tetraethyl orthosilicate”,
Proc. 2nd Annual Meeting of COST Action CM 1301, CELINA - Chemistry for Electron-Induced Nanofabrication, May 6-9, 2015, Bratislava, Slovakia, Book of Abstracts, Eds. Peter Papp and Petra Swiderek, (COST Action CM 1301, Comenius University, Bratislava, Slovakia), STSM Report, WG1, p.29.

<http://neon.dpp.fmph.uniba.sk/celina2015/>

Acknowledgements: grants – Slovak Research and Development Agency under Contract No. APVV-0733-11; MESTD RS OI #171020; COST Action CM1301 (CELINA).

ISBN: / (The Comenius University, Bratislava, Slovakia)

3. ЕЛЕМЕНТИ ЗА КВАЛИТАТИВНУ ОЦЕНУ НАУЧНОГ ДОПРИНОСА

КАНДИДАТА

3.1 Квалитет научних резултата

3.1.1 Научни ниво и значај резултата, утицај научних радова

Јелена Маљковић је у свом досадашњем научном раду објавила укупно 14 радова у међународним часописима, једно предавање по позиву са међународног скупа штампано у целини, 5 предавања по позиву са међународних скупова штампана у изводу, 5 саопштења са међународних скупова штампана у целини, 14 саопштења са међународних скупова штампана у изводу, 2 предавање по позиву са скупа националног значаја штампана у целини, 1 саопштења са скупа националног значаја штампана у целини и 2 саопштења са скупа националног значаја штампана у изводу.

Кандидаткиња је након претходног избора у звање научни сарадник објавила 7 радова у међународним часописима са ISI листе. **Четири рада су категорије M21** (врхунски међународни часописи), **један у категорији M22**, **два у категорији M23**. Поред тога, објавила је **1 рад категорије M31** (предавање по позиву са међународног скупа штампано у целини), **4 рада категорије M32** (предавање по позиву са међународног скупа штампано у изводу), **2 категорије M33** (саопштење са међународног скупа штампано у целини) и **9 радова категорије M34** (саопштење са међународног скупа штампано у изводу).

Као пет најзначајнијих радова др Јелене Маљковић могуће је издвојити:

1. (M21) Jelena Vukalović, **Jelena B. Maljković**, Francisco Blanco, Gustavo García, Branko Predojević, Bratislav P. Marinković,

“Absolute differential cross-sections for elastic electron scattering from sevoflurane molecule in the energy range from 50-300 eV”,

Int. J. Molec. Sci. 23(1) 21 (2022). M21=8, ИФ=5.924, цитиран 0 пута (рад је тек изашао)

2. Janina Kopyra, Paulina Maciejewska and **Jelena Maljković**,

“Dissociative electron attachment to coordination complexes of chromium: chromium(0) hexacarbonyl and benzene-chromium(0) tricarbonyl”,

Beilstein J. Nanotechnol. **8**, 2257–2263 (2017), M21=8; ИФ=3.127, цитиран 5 пута

3. J. B. Maljković, A. R. Milosavljević, F. Blanco, D. Šević, G. García, and B. P. Marinković,

“Absolute differential cross sections for elastic scattering of electrons from pyrimidine”,

Phys. Rev. A **79**, 052706 (2009), M21=8; ИФ =2.908, цитиран 53 пута

4. J. B. Maljković, F. Blanco, R. Čurik, G. García, B. P. Marinković, and A. R. Milosavljević,

“Absolute cross sections for electron scattering from furan”,

J. Chem. Phys. **137** 064312 (2012), M21=8, ИФ=3.164, цитиран 10 пута

5. Jelena Vukalović, Jelena B. Maljković, Karoly Tökési, Branko Predojević, Bratislav P. Marinković,

“Elastic electron scattering from methane molecule in the energy range from 50-300 eV”,

Int. J. Molec. Sci. **22**(2) 647 (2021) . M21=8, ИФ=5.924, цитиран 1 пут

У првом раду објављеном у *International Journal of Molecular Sciences* **23**(1) 21 (2022) су приказани теоријски и експериментални апсолутни диференцијални пресеци за еластично расејање електрона на молекулима севофлурана, једног од најчешће коришћених халогених анестетика. Интересовање за проучавање анестетика у последње време је порасла и са чињеницом да халогени анестетици су битни због њихове улоге у атмосферској хемији, заједно са улогом хлорофлуорокарбона у оштећењу озонског омотача у стратосфери. Инхалациони анестетици се врло мало метаболички мењају при клиничкој употреби, тако да молекули анестетика са дугим временом живота могу стићи у стратосферу у великој количини. Експериментални и теоријски резултати се јако добро слажу на апсолутној скали, што говори о поузданости наше експерименталне методе.

У другом раду објављеном у *Beilstein J. Nanotechnol.* **8**, 2257–2263 (2017), смо разматрали на примеру молекула $\text{Cr}(\text{CO})_6$ и $(\eta^6\text{-C}_6\text{H}_6)\text{Cr}(\text{CO})_3$ како замена три CO групе са C_6H_6 има утицаја у случају интеракције ових молекула са електронима. Кандидаткиња је овај рад објавила током научне посете Пољској у оквиру COST акције CELINA. У оквиру потенцијалне улоге хромјум једињења у FEBID апликацијама утврдили смо да “откидање” C_6H_6 и свих CO лиганата и формирање чистог $[\text{Cr}]^-$ је могуће путем процеса дисоцијативног електронског захвата.

У трећем раду објављеном у *Phys. Rev. A* **79**, 052706 (2009) смо приказали теоријска и експериментална истраживања еластичног расејања електрона на пиримидину, молекулу који је аналоган пиримидинским базама. Мерења су рађена на упадним енергија 50-300 eV и упадним угловима 20°-110°. Релативни диференцијални пресеци су мерени у функцији угла и упадне енергије електрона и нормирани су на апсолутну скалу на основу тачака добијених Relative flow методом. Теоријски прорачуни су базирани на коригованој форми метода независних атома (Independent Atom Method- IAM).

У четвртном раду објављеном у *J. Chem. Phys.* **137** 064312 (2012), приказани су резултати за фуран молекул, апсолутни пресеци у функцији угла за енергије 50-300 eV, 20°-110°, табеларно и графички. Ови апсолутни пресеци у функцији угла су упоређени са SCARND и UFBA теоријом, као и са ранијим експерименталним резултатима. На примеру молекула фурана, у сарадњи са колегом Р. Чуриком из Прага, разматран је утицај вибрационих стања која се не могу у експерименту раздвојити од еластичног

расејања на средњим енергијама. Дат је такође график ротационо сумираних вибрационих нееластичних апсолутних пресека и односа суме вибрационих нееластичних апсолутних пресека према еластичним. На крају су представљени, графички и табеларно, интегрални и тотални пресеци и упоређени са ранијим резултатима.

У петом раду објављеном у *International Journal of Molecular Sciences* **22**(2) 647 (2021) су презентовани експериментално добијени диференцијални пресеци за еластично расејање електрона на метану (CH₄), гасу који у великој мери, доприноси ефекту "стаклене баште". Експериментални резултати су упоређени са два сета теоријских података једним добијеним обичном сумом индивидуалних атома а другим добијеним узимајући и ефекте молекула у обзир. Експериментални и теоријски резултати се добро слажу на апсолутној скали и са предходно добијеним резултатима других аутора, што говори и о поузданости наше експерименталне методе и теоријског метода.

3.1.2 Позитивна цитираност научних радова кандидата

Према бази Web of Science, радови др Јелене Маљковић укупно су цитирани 154 пута, док је број цитата без ауоцитата 132. Хиршов индекс је $h=7$.

Прилог: подаци о цитираности радова из интернет базе Web of Science

3.1.3 Параметри квалитета радова и часописа

Као битан елемент за процену квалитета научних радова служи и импакт-фактор часописа у којима су радови објављени.

Од предходног избора у звање кандидаткиња је објављивала радове у часописима категорија M21, M22 и M23 :

Категорија M21:

2 рада у *International Journal of Molecular Sciences*, Impact Factor (5.924)

1 рада у *Nucl. Instrum. Meth. B*, Impact Factor (1.389)

1 рад у *Beilstein J. Nanotechnol*, Impact Factor (3.127)

Категорија M22:

1 рад у *Nucl. Instrum. Meth. B*, Impact Factor (1.210)

Категорија M23:

1 рад у *Eur.Phys.J.D.*, Impact factor (1.288)

1 рад у *Eur. Phys. J.D* , Impact Factor (1,288)

Укупан импакт фактор ових радова је **20.15**.

Часописи у којима објављује др Јелена Маљковић су цењени по свом угледу и водећи у његовим областима рада. Додатни библиометријски показатељи према упутству о начину писања извештаја о изборима у звања које је усвојио Матични научни одбор за физику приказани су у следећој табели:

	ИФ	М	СНИП
Укупно	20,15	43	6.947
Усредњено по чланку	2.88	6.14	0.992
Усредњено по аутору	3.964	8.53	1.353

3.1.4 Степен самосталности и степен учешћа у реализацији радова у научним центрима у земљи и иностранству

Од 14 објављених радова, др Јелена Маљковић је први аутор на 7 радова. На радовима који су објављени у периоду након одлуке Научног већа Института за физику о предлогу за стицање претходног научног звања, кандидаткиња је објавила 7 радова и први је аутор на 2 рада.

При изради поменутих публикација кандидаткиња је учествовала у осмишљавању мета коришћених за истраживање, експерименталним мерењима, на обради и анализи добијених резултата и писању радова.

Током докторских студија, под менторством др Александра Милосављевића с Института за физику у Београду, др Јелена Маљковић је започела истраживање у области радијационог оштећења живе материје, под утицајем електрона средњих енергија (40-300 eV). У том контексту, проширено је експериментално истраживање интеракције електрона средњих енергија са молекулима који су аналогни неким деловима ДНК. Започет је развој методе за мерење апсолутних диференцијалних пресека (Relative flow метод) за еластично расејање електрона на биомолекулима, аналогним неким деловима молекула релавантним за грађу биолошких макромолекула. Након завршеног доктората, кандидаткиња је наставила да се бави проблемом интеракције електрона средњих енергија са биомолекулима и започела је рад на интеракцији електрона средњих енергија са анестетицима, метану и металним капиларама. У оквиру националног пројекта ОI 171020 Физика судара и фотопроеца у атомским, (био)молекулским и нано система, руководилац је пројектног задатка:

Проучавање електронске интерације са (био)молекулима, анестетичима и наночестицама. Поред ових тема, у сарадњи са колегама из Словачке и Пољске, кандидаткиња се бавила проучавањем процеса дисоцијативне јонизације и дисоцијативног електронског захвата на органометалицима који су потенцијални FEBID прекурсори. У оквиру COST акције CELINA кандидаткиња је у више наврата боравила у Словачкој и Пољској, где је остварила научну сарадњу са проф др Штефаном Матејчиком, др Петром Пап и проф др Јанином Копиром . Из ове сарадње објављена су два рада и одржана два предавања на међународним конференцијама.

3.1.5. Елементи примењивости научних резултата

Резултати радова са биомолекулима су значајни у циљу изучавања директног оштећења биолошког материјала услед дејства јонизујућег зрачења. Експерименти у којима се истражује процес интеракције електрона са молекулима који су аналогни градивним деловима ДНК и протеина су зато јако битни. Спектроскопски подаци и апсолутни диференцијални пресеци за интеракцију електрона са ДНК су потребни као почетни параметри у моделовању процеса оштећења и разумевању реакција. Добијање диференцијалних ефикасних пресека за расејање електрона на биомолекулима је важно за тестирање теоријских модела који се примењују за прорачун сударних процеса. Такође поуздано измерени диференцијални пресеци представљају важне улазне параметре за Monte Carlo симулације депозиције енергије у живој материји услед дејства јонизујућег зрачења. Треба истаћи да је поуздан прорачун радијационог оштећења произведеног високоенергијским честицама битан део истраживања повезаног са канцер терапијом.

Резултати радова са органометалицима имају значајне примене како су органометалици велика група једињења са бројним апликацијама у фармацеутској индустрији и нанотехнологији. Велики број органометалика су препознати као обећавајући прекурсори за Focused Electron Beam Induced Deposition (FEBID), процесе за фабриковање три-димензионалних металних наноструктура.

3.2 Ангажованост у формирању научних кадрова

Кандидаткиња је била ментор на изради мастер рада Јелене Вуковић (сад Вукаловић), одбрањеног 2018-те године. Др Јелена Маљковић је тренутно ментор на докторским студијама Јелене Вуковић (Вукаловић),

Прилог: потврда о менторству на мастер и докторским студијама

3.3 Нормирање броја коауторских радова, патената и техничких решења

Сви радови кандидаткиње објављени након одлуке Научног већа Института за физику о предлогу за стицање претходног научног звања укључују резултате експерименталног истраживања интеракције електрона са биомолекулима, анестетицима, метану, металним капиларама и органометалицима. Од тога, сви радови имају мање или 7 коатора, тако да улазе пуном тежином. Укупан број поена М поена др Јелене Маљковић у релевантном периоду, од предходног избора у звање, износи 59 што је изнад захтеваног броја бодова за избор у звање виши научни сарадник..

3.4 Руковођење пројектима, потпројектима и пројектним задацима

У оквиру националног пројекта ОИ171020 , Физика судара и фотопроеца у атомским, (био)молекулским и нанодимензионим системима, др Јелена Маљковић је руководилац пројектним задатком: Проучавање електронске интеракције са биомолекулским, анестетицима и наночестицама.

Прилог: потврда вође пројекта о руковођењу наведеним пројектним задатком.

3.5 Активност у научним и научно-стручним друштвима

- Др Јелена Маљковић је члан Одељења Друштва физичара Србије за научна истраживања и високо образовање у Одсеку за атомску и молекулску физику.
- Кандидаткиња је била члан менаџмент комитета COST акције CM1301 “Chemistry for Electron-Induced Nanofabrication (CELINA). Approval date: 16/05/2013, End of Action: 15/05/2017.
Прилог: записник са седнице Научног већа, позив CELINA акције за чланство у менаџмент комитету акције.
- Кандидаткиња је заменик члана менаџмент комитета COST акције CA18212 “Molecular Dynamics in the GAS phase”, Start of Action - 12/11/2019 End of Action - 11/11/2023
Прилог : позив MD COST акције за заменика члана менаџмент комитета
- Кандидаткиња је учесник COST акције CA20129 “Multiscale Irradiation and Chemistry Driven Processes and Related Technologies” Start of Action - 04/10/2021 End of Action - 03/10/2025
Прилог : позив акције CA20129 “Multiscale Irradiation and Chemistry Driven Processes and Related Technologies” за чланство

3.6 Утицајност научних резултата

Утицај научних радова кандидаткиње детаљно је приказан у одељку 3.1 овог документа **Квалитет научних резултата.**

3.7 Конкретан допринос кандидата у реализацији радова у земљи и иностранству

Др Јелена Маљковић је значајно допринела сваком раду у чијој припреми је учествовала. Од 7 радова објављених у периоду након одлуке Научног већа Института за физику о предлогу за стицање претходног научног звања, сви радови су урађени у сарадњи с колегама из земље и иностранства. Кандидаткиња је у овим радовима имала кључни допринос: на 2 рада је први аутор, а на 3 рада је наведена као други аутор а на једном као последњи. Током израде ових публикација, она је радила на осмишљавању мета интересантних за истраживања, експерименталним мерењима, обради и анализи резултата и писању радова. Знања и искуства које је стекла у експерименталном раду и обради података добијених у експерименталним истраживањима кандидаткиња преноси млађим сарадницима у Лабораторији за атомске сударне процесе.

3.8 Уводна предавања на конференцијама и друга предавања

Након претходног избора у звање, др Јелена Маљковић је одржала следећа предавања по позиву:

1. 6th Conference on Elementary Processes in Atomic Systems – CEPAS 2014, 9th - 12th July 2014, Bratislava, Slovakia.
2. 27th Summer School and International Symposium on the Physics of Ionized Gases – SPIG 2014, 26-29 August 2014, Belgrade, Serbia.
3. 2nd Annual Meeting of COST Action CM 1301, CELINA - Chemistry for ELelectron-Induced Nanofabrication, May 6-9, 2015, Bratislava, Slovakia.
4. 3rd Annual Meeting of COST Action CM 1301, CELINA - Chemistry for ELelectron-Induced Nanofabrication, May 18-20, 2016, Kraków, Poland
5. Атомско-молекуларне базе података, Тренинг, 23.11.2017, Универзитет у Бањој Луци ОЈ Природно-математички факултет
6. 7th International Conference on Many Particle Spectroscopy of Atoms, Molecules, Clusters and Surfaces – MPS2018, 21-24 August 2018, Budapest, Hungary,
7. 1st General Meeting of the COST Action: MD-GAS (Molecular Dynamics in the GAS-phase). February 18-21, 2020. Caen, France

Прилог: позиви за предавања, позив за предавање на првом MD GAS конференцији, MPS конференцији, распоред предавача са CELINA састанка у Братислави, позив за предавање у Бања Луци

Елементи за квантитативну анализу научног доприноса

Остварени М-бодови кандидата по категоријама публикација:

Категорија	М бодова по раду	Број радова	Укупно М бодова	Нормализовано М бодова
M21	8	4	32	32
M22	5	1	5	5
M23	3	2	6	6
M31	3.5	1	3.5	3.5
M32	1.5	4	6	6
M33	1	2	2	2
M34	0.5	9	4.5	4.5

Поређење оствареног броја М-бодова са минималним условима потребним за избор у звање виши научни сарадник:

Минималан број М бодова		Остварено	Остварено (нормализовано)
Укупно	50	59	59
M10+M20+M31+M32+M33+M41+M42	40	54.5	54.5
M11+M12+M21+M22+M23	30	43	43

УКУПАН СПИСАК НАУЧНИХ РАДОВА

МОНОГРАФИЈЕ, МОНОГРАФСКЕ СТУДИЈЕ, ТЕМАТСКИ ЗБОРНИЦИ, ЛЕКСИКОГРАФСКЕ И КАРТОГРАФСКЕ ПУБЛИКАЦИЈЕ МЕЂУНАРОДНОГ ЗНАЧАЈА

M14

1. Cross section data for electron collisions in plasma physics

B. P. Marinković, V. Pejčev, D. M. Filipović, D. Šević, A. R. Milosavljević, S. Milisavljević, M. S. Rabasović, D. Pavlović and J. B. Maljković

Journal of Physics: Conference Series, **86**, 012006 (2007).

РАДОВИ ОБЈАВЉЕНИ У НАУЧНИМ ЧАСОПИСИМА МЕЂУНАРОДНОГ ЗНАЧАЈА

Напомена: Звездицом () су означени радови објављени након предходног избора у звање.*

M 21

1.* Jelena Vukalović, Jelena B. Maljković, Francisco Blanco, Gustavo García, Branko Predojević, Bratislav P. Marinković,

“Absolute differential cross-sections for elastic electron scattering from sevoflurane molecule in the energy range from 50-300 eV”,

Int. J. Molec. Sci. 23(1) 21 (2022) [11pp].

Special Issue "Electron and Photon Interactions with Bio(Related) Molecules"

[doi: 10.3390/ijms23010021](https://doi.org/10.3390/ijms23010021)

ISSN: 1422-0067

2.* Jelena Vukalović, Jelena B. Maljković, Karoly Tökési, Branko Predojević, Bratislav P. Marinković,

“Elastic electron scattering from methane molecule in the energy range from 50-300 eV”,

Int. J. Molec. Sci. 22(2) 647 (2021) [14pp].

Special Issue "[Electron and Photon Interactions with Bio\(Related\) Molecules](#)"

[doi: 10.3390/ijms22020647](https://doi.org/10.3390/ijms22020647)

ISSN: 1422-0067

3.* Janina Kopyra, Paulina Maciejewska and Jelena Maljković,

“Dissociative electron attachment to coordination complexes of chromium: chromium(0) hexacarbonyl and benzene-chromium(0) tricarbonyl”,

Beilstein J. Nanotechnol. **8**, 2257–2263 (2017).

[doi: 10.3762/bjnano.8.225](https://doi.org/10.3762/bjnano.8.225)

ISSN: 2190-4286

4.* A. R. Milosavljević, M. Lj. Ranković, D. Borka, J. B. Maljković, R. J. Berezky, B. P. Marinković and K. Tőkési,

“Study of electron transmission through a platinum tube”,

Nucl. Instrum. Meth. B **354**, 86-89 (2015). [on-line 15 Dec 2014]

Original Research Article 26th International Conference on Atomic Collisions in Solids, Edited by Károly Tőkési, Réka Judit Berezky, István Rajta and Iván Valastyán.

[DOI: 10.1016/j.nimb.2014.11.087](https://doi.org/10.1016/j.nimb.2014.11.087)

5. M Danko, J Orszagh, M Durian, J Kočišek, M Daxner, S Zöttl, J B Maljković, J Fedor, P Scheier, S Denifl and Š Matejčik,

“Electron impact excitation of methane: determination of appearance energies for dissociation products”

J. Phys. B: At. Mol. Opt. Phys **46** 045203 (2013)

[DOI: 10.1088/0953-4075/46/4/045203](https://doi.org/10.1088/0953-4075/46/4/045203)

6. J. B. Maljković, F. Blanco, R. Čurik, G. García, B. P. Marinković, and A. R. Milosavljević, *“Absolute cross sections for electron scattering from furan”*,

J. Phys. Chem. **137** 064312 (2012) [10 pages].

<http://link.aip.org/link/?JCP/137/064312>

[DOI: 10.1063/1.4742759](https://doi.org/10.1063/1.4742759)

7. J. B. Maljković, F. Blanco, G. García, B. P. Marinković, and A. R. Milosavljević,

“Absolute cross sections for elastic electron scattering from methylformamide”,

Physical Review A **85**, 042723 (2012) [8 pages].

<http://link.aps.org/doi/10.1103/PhysRevA.85.042723>

[DOI: 10.1103/PhysRevA.85.042723](https://doi.org/10.1103/PhysRevA.85.042723)

8. J. B. Maljković, A. R. Milosavljević, F. Blanco, D. Šević, G. García, and B. P. Marinković,

“Absolute differential cross sections for elastic scattering of electrons from pyrimidine”,

Phys. Rev. A **79**, 052706 (2009) [7 pages].

<http://link.aps.org/doi/10.1103/PhysRevA.79.052706>

[DOI: 10.1103/PhysRevA.79.052706](https://doi.org/10.1103/PhysRevA.79.052706)

M 22

1.* J.B. Maljković, D. Borka, M. Lj. Ranković, B.P. Marinković, A.R. Milosavljević, C. Lemell, and K. Tőkési,

“Electron transmission through a steel capillary”,

Nucl. Instrum. Meth. B, **423**, 87–91 (2018).

[DOI: 10.1016/j.nimb.2018.03.020](https://doi.org/10.1016/j.nimb.2018.03.020)

2. J. B. Maljković, F. Blanco, G. García, B. P. Marinković, and A. R. Milosavljević,

“*Elastic electron scattering from formamide molecule*”,

Nucl. Instrum. Meth. B. **279** 124-127 (2012).

Special issue: Proceedings of the *Fifth International Conference on Elementary Processes in Atomic Systems*, Belgrade, Serbia, 21-25 June 2011, Edited by Bratislav Marinković and Károly Tökési.

[doi:10.1016/j.nimb.2011.10.029](https://doi.org/10.1016/j.nimb.2011.10.029)

M 23

1. *Jelena B. Maljković, Jelena Vuković, Károly Tökési, Branko Predojević, and Bratislav P. Marinković,

“*Elastic electron scattering cross sections for triethyl phosphate molecule at intermediate electron energies from 50 to 250 eV*”,

Eur. Phys. J.D **73**, 27 (2019). [5pp] (on-line 5 Feb 2019)

Part of the topical issue: Many Particle Spectroscopy of Atoms, Molecules, Clusters and Surfaces

[DOI: 10.1140/epjd/e2019-90631-1](https://doi.org/10.1140/epjd/e2019-90631-1)

ISSN: 1434-6060

2. * Miloš Lj. Ranković, Jelena B. Maljković, Károly Tökési, and Bratislav P. Marinković, #

“*Elastic electron differential cross sections for argon atom in the intermediate energy range from 40 eV to 300 eV*”,

Eur. Phys. J.D **72**, 30 (2018) [9pp]

Part of the topical issue: Physics of Ionized Gases (SPIG 2016)

[DOI: 10.1140/epjd/e2017-80677-4](https://doi.org/10.1140/epjd/e2017-80677-4)

3. A. R. Milosavljević, F. Blanco, J. B. Maljković, D. Šević, G. García, and B. P. Marinković,

“*Absolute cross sections for elastic electron scattering from 3-hydroxytetrahydrofuran*”,

New J. Phys. **10** 103005 (2008) [19 pages].

[doi: 10.1088/1367-2630/10/10/103005](https://doi.org/10.1088/1367-2630/10/10/103005)

4. B. P. Marinković, A. R. Milosavljević, J. B. Maljković, D. Šević, B. A. Petruševski, D. Pavlović, D. M. Filipović, M. Terzić and V. Pejčev,

“*Optical and Electron Spectrometry of Molecules of Biological Interest*”,

Acta Physica Polonica A **112**(5) 1143-1148 (2007).

Proceedings of the International School and Conference on Optics and Optical Materials, ISCOM07, September 3-7, 2007, Belgrade, Serbia.

ISSN: 0001-673X

ЗБОРНИЦИ СА МЕЂУНАРОДНИХ НАУЧНИХ СКУПОВА

M31

1. *J. B. Maljković

“Absolute differential cross sections for elastic electron scattering from small biomolecules”,
Proc. 27th Summer School and Int. Symp. on Physics of Ionized Gases – SPIG 2014, 26th -
29th August 2014, Belgrade, Serbia, Contributed Papers & Abstracts of Invited Lectures,
Topical Invited Lectures, Progress Reports and Workshop Lectures, Editors: Dragana Marić,
Aleksandar R. Milosavljević and Zoran Mijatović, (IOP Belgrade and SASA, Belgrade,
Serbia), Progress Report, p.18.

<http://www.spig2014.ipb.ac.rs/>

ISBN: 978-86-7762-600-6.

Also: *J. Phys. Conf. Ser.* **565** 012005 (2014) [6pp]

[doi:10.1088/1742-6596/565/1/012005](https://doi.org/10.1088/1742-6596/565/1/012005)

M32

1. *J. Vuković, B. P. Marinković, B. Predojević, K. Tökési, J. Maljković,

“Elastic electron scattering by triethyl phosphate molecule – experimental and theoretical study”,
Proc. 7th International Conference on Many Particle Spectroscopy of Atoms, Molecules, Clusters and Surfaces (MPS2018), 21-24 August 2018, Budapest, Hungary,
Károly Tökési (Chair), Programme and Book of Abstracts, Editors: K. Tökési, B. Paripás, G.
Pszota, Invited Lecture I14, p.25.

ISBN 978-615-00-2859-0

2. *Jelena Maljković, Paulina Maciejewska and Janina Kopyra,

“Dissociative electron attachment to benzene chromium tricarbonyl”

Proc. The 3rd CELINA Meeting, Kraków, May 18-20, 2016, Eds. Petra Swiderek and
Janina Kopyra, p.20

Organized by “Siedlice University of Natural Sciences and Humanities” and “Academic
Centre for Materials and Nanotechnology of the AGH University of Science and Technology
in Kraków”

3. *Jelena Maljković, Peter Papp, Michal Lacko, Michal Stano, Aleksandar Milosavljević, Stefan Matejcik

“Electron impact dissociative ionization of tetraethyl orthosilicate”,

Proc. 2nd Annual Meeting of COST Action CM 1301, CELINA - Chemistry for Electron-Induced Nanofabrication, May 6-9, 2015, Bratislava, Slovakia, Book of Abstracts, Eds. Peter Papp and Petra Swiderek, (COST Action CM 1301, Comenius University, Bratislava, Slovakia), STSM Report, WG1, p.29.

4. *J. B. Maljković, F. Blanco, G. García, B. P. Marinković and A. R. Milosavljević, “*Absolute Cross Sections for Elastic Electron Scattering from Furan and THF Molecules*”, *Proc. 6th Conference on Elementary Processes in Atomic Systems – CEPAS 2014*, 9th - 12th July 2014, Bratislava, Slovakia, Contributed Papers, Editors: Štefan Matejčík, Peter Papp and Ondrej Bogár, (Comenius University, Faculty of mathematics physics and informatics, Bratislava, Slovakia), pp.133-135.
ISBN: 987-80-8147-021-9.

5 A. R. Milosavljević, F. Blanco, J. B. Maljković, G. García, B. P. Marinković, “*Absolute differential cross sections for electron scattering from building blocks of biopolymers*”, *Proc. 5th Conference on Elementary Processes in Atomic Systems (CEPAS2011) and the 2nd National Conference on Electronic, Atomic, Molecular and Photonic Physics (CEAMPP2011)*, 21st – 25th June 2011, Belgrade, Serbia, Contributed Papers & Abstracts of Invited Lectures, Editors: Aleksandar R. Milosavljević, Saša Dujko and Bratislav P. Marinković, Abstract of Invited Topical Lecture, p.28.
ISBN: 978-86-82441-32-8
Acknowledgements: MES Serbia (# 171020), Spanish MCIP (#FIS2009-10245), COST ECCL and COST nano-IBCT.

.M 33

1. *Jelena Maljković, Paulina Maciejewska and Janina Kopyra, “*Dissociative Electron Attachment to Benzene Chromium Tricarbonyl*”, *Proc. 28th Summer School and Int. Symp. on Physics of Ionized Gases – SPIG 2016*, August 29th –Sept. 2nd 2016, Belgrade, Serbia, Contributed Papers & Abstracts of Invited Lectures, Topical Invited Lectures, Progress Reports and Workshop Lectures, ISBN: 978-86-84539-14-6.
Acknowledgements: grants – MESTD RS OI #171020, Polish Ministry of Science and Higher Education (Project No. 277/S/11), and COST Action CM1301 (CELINA

2. *A. R. Milosavljević, M. Lj. Ranković, J. B. Maljković, R. J. Bereczky, B. P. Marinković and K. Tökési, “*Kinetic Energy Distribution of Electrons Scattered Inside a Platinum Tube at the Incident Energy of 200 eV*”,

Proc. 27th Summer School and Int. Symp. on Physics of Ionized Gases – SPIG 2014, 26th - 29th August 2014, Belgrade, Serbia, Contributed Papers & Abstracts of Invited Lectures, Topical Invited Lectures, Progress Reports and Workshop Lectures, Editors: Dragana Marić, Aleksandar R. Milosavljević and Zoran Mijatović, (IOP Belgrade and SASA, Belgrade, Serbia), Poster Presentation 2.11, pp.210-213.

<http://www.spig2014.ipb.ac.rs/>

ISBN: 978-86-7762-600-6.

Acknowledgements: projects – MESTD RS (OI #171020); Hungarian SRF OTKA #NN 103279; bilateral program SASA-HAS and COST Action CM1301 (CELINA).

3. Aleksandar R. Milosavljević, Jelena B. Maljković, Dragutin Šević, Iztok Čadež and Bratislav P. Marinković,

“Measurement of kinetic energy distribution of positive ions from electron induced dissociation of pyrimidine molecule”,

Proc. 25th Summer School and International Symposium on Physics of Ionized Gases SPIG, 30th Aug – 4th Sept. 2010, Donji Milanovac, Serbia, Book of Contributed Papers and Abstracts of Invited Lectures, Topical Invited Lectures and Progress Reports, editors: L. Č. Popović and M. M. Kuraica, ISBN 978-86-80019-37-6,

Publ. Astron. Obs. Belgrade No. 89, July 2010, ISSN: 0373-3742 pp. 37 – 40.

4. Jelena B. Maljković, Aleksandar R. Milosavljević, Zoran Pešić, F. Blanco, G. García, Dragutin Šević and Bratislav P. Marinković,

“Absolute differential cross section for elastic electron scattering from halothane at 100eV

Proc. 25th Summer School and International Symposium on Physics of Ionized Gases SPIG, 30th Aug – 4th Sept. 2010, Donji Milanovac, Serbia, Book of Contributed Papers and Abstracts of Invited Lectures, Topical Invited Lectures and Progress Reports, editors: L. Č. Popović and M. M. Kuraica, ISBN 978-86-80019-37-6,

Publ. Astron. Obs. Belgrade No. 89, July 2010, ISSN: 0373-3742 pp. 33 – 36.

5. A. R. Milosavljević, F. Canon, J. B. Maljković, L. Nahon and A. Giuliani,
“Photodissociation of pure and nanosolvated protonated leucineenkephalin peptide”,
Proc. 26th Summer School and International Symposium on Physics of Ionized Gases SPIG, 27th – 30th Aug. 2012, Zrenjanin, Serbia, Book of Contributed Papers & Abstracts of Invited Lectures and Progress Reports, editors: M. Kuraica and Z. Mijatović, ISBN 978-86-7031-242-5(print) and 978-86-7031-244-9(e-book), *Contributed Paper*, pp.55 – 58.

<http://spig2012.pmf.uns.ac.rs/>

M 34

1. *J B Maljković, J Vuković, K Tökési, B Predojević and B P Marinković,
“Integral cross sections for elastic electron scattering by methane molecule”,

Proc. The 31st International Conference on Photonic, Electronic and Atomic Collisions (XXXI ICPEAC), 23 July – 30 July 2019, Deauville, France, *Book of Abstracts Special Reports and Posters*, Eds. H. Bachau, R. Brédy, O. Dulieu, E. Lamour, F. Penent, C. Prigent, M. Trassinelli, D. Vernhet, (INSP, Paris, 2019), Poster FR-117, p.541.

Journal of Physics: Conference Series 1412, 182012 (2020).

[doi: 10.1088/1742-6596/1412/18/182012](https://doi.org/10.1088/1742-6596/1412/18/182012)

2. *J. Vuković, J. B. Maljković, B. Predojević and B. P. Marinković, “Absolute Differential Cross Sections for Electron Scattering from Anaesthetic Molecules”, *Proc. XX International Workshop on Low-Energy Positron and Positronium Physics, XXI International Symposium on Electron-Molecule Collisions and Swarms and V Workshop on Non-Equilibrium Processes – POSMOL2019*, 18 - 20 July 2019 Belgrade, Serbia, Book of Abstracts, eds. D. Cassidy, M.J. Brunger, Z.Lj. Petrović, S. Dujko, B.P. Marinković, D. Marić and S. Tošić (Serbian Academy of Sciences and Arts and Institute of Physics Belgrade, Serbia, 2019) Poster EMS 43, p.125.
ISBN 978-86-7025-819-8

3. * J.B. Maljković, J. Vuković, K. Tökési, B. Predojević, B.P. Marinković, “Elastic electron scattering from methane molecule in the energy range from 50-300 eV”, *Proc. 13th European Conference on Atoms Molecules and Photons (ECAMP13)*, April 8-12, 2019, Florence, Italy, *Abstract Book*, Eds. G.M. Tino et al., P3.37 Poster presentation, p.319. (The Atomic, Molecular and Optical Physics Division - AMOPD of the European Physical Society EPS, University of Florence, 2019).

4. *B.P. Marinkovic, M.Lj. Rankovic, J.B. Maljkovic, A.R. Milosavljevic, D. Borcka, C. Lemell, K. Tökési, “Electron transmission through steel capillary”, *Proc. 7th Conference on Elementary Processes in Atomic Systems (CEPAS 2017)*, 3rd – 6th September 2017, Průhonice, Czech Republic, Editors: M. Tarana, R. Čurík (J. Heyrovský Institute of Physical Chemistry, Prague, 2017), Abstracts of Posters, p.47.
ISBN: 978-80-87351-46-8

5. * Jelena Maljković, Sylwia Mazuryk, and Janina Kopyra, “Dissociative electron attachment to cyclopentadienylmanganese(I) tricarbonyl”, *Proc. 4th CELINA Annual Meeting: Chemistry for Electron-Induced Nanofabrication (CELINA) COST Action CM1301*, Porto, Portugal, 13-16 September, 2017. Book of Abstracts, Eds. Filipe Ferreira da Silva and GonçaloMagalhães-Mota (Universidade Nova de Lisboa, Lisboa, 2017) Poster Abstracts P-12, p.48.

6. *M. Lacko, J. Maljković, P. Papp, A. Milosavljević, Š. Matejčík,

“Electron ionization of Tetraethyl orthosilicate molecule as a FEBID precursor”
ICPEAC 2015, 22–28 July 2015, Toledo, Spain

7. *A.R. Milosavljević, M.L. Ranković, D. Borka, J. Maljković, R. Bereczky, B. Marinković, K. Tőkési,

“Study of electron transmission through a metallic capillary”

XXIX International Conference on Photonic, Electronic, and Atomic Collisions (ICPEAC2015), 22–28 July 2015, Toledo, Spain, Abstracts, TU-106.

Journal of Physics: Conference Series **635**, 062011 (2015).

[doi:10.1088/1742-6596/635/6/062011](https://doi.org/10.1088/1742-6596/635/6/062011)

ISSN: 1742-6588 (IOP Publishers, UK)

8. *J. B. Maljković, M. Lj Ranković, R. J. Bereczky, B. P. Marinković, K. Tőkési, A. R. Milosavljević,

“Electron transmission through a metallic capillary”,

Proc. 26th International Conference on Atomic Collisions in Solids (ICACS-26), 13th – 18th July 2014, Debrecen, Hungary, Book of Abstracts, Editor: Attila Csík, Poster presentation P23, p.59.

ISBN: 978-963-08-9865-2, (ATOMKI, Institute for Nuclear Research, Hungarian Academy of Sciences, Debrecen, Hungary).

9. *Aleksandar R. Milosavljević, Jelena B. Maljković, Réka J. Bereczky, Miloš Lj. Ranković, Bratislav P. Marinković and Károly Tőkési,

“Transport of electrons through a long metallic microcapillary: characterization of the outgoing low-energy electron beam”,

Proc. The First Annual Meeting of COST Action CM1301 (CELINA), 19th - 22nd March 2014, Erlangen, Germany,

10. A. R. Milosavljević, J. B. Maljković, D. Šević and B. P. Marinković,

“Electron interaction with biologically relevant molecules in gaseous phase”,

Research Conference, ESF-FWF Conference in Partnership with LFUI, *“Chemical Control with Electrons and Photons”*, Chairs: P. Swiderek and N. J. Mason, 22-27 November, 2008, Obergurgl, Austria, Poster Abstracts 30.

11. J. Maljković, A. R. Milosavljević, D. Šević and B. P. Marinković,

“Relative angle-differential cross sections for elastic electron scattering from pyrimidine”,

Proc. 24th Symposium on Physics of Ionized Gases – SPIG’2008, Contributed Papers and Abstracts of Invited Lectures, Topical Invited Lectures and Progress Reports, 25 – 29 August 2008, Novi Sad, Serbia, Eds. G. Malović, L. Č. Popović and M. S. Dimitrijević (Belgrade, Astronomical Observatory) Publ. Astron. Obs. Belgrade, No. 84, July 2008, Contributed Paper, pp. 45 – 48.

12 A. R. Milosavljević, F. Blanco, J. B. Maljković, G. García, B. P. Marinković,
“Absolute cross sections for electron interaction with molecules representing sub-units of
biopolymers”,

The 1st Nano-IBCT Conference on Radiation damage of biomolecular systems: Nano-scale
insights into Ion Beam Cancer Therapy, 2 - 6 Oct. 2011, Caen, France, Poster presentation

13 J. B. Maljković, F. Blanco, G. García, B. P. Marinković, A. R. Milosavljević,
“Elastic electron scattering from formamide molecule”,
Proc. 5th *Conference on Elementary Processes in Atomic Systems* (CEPAS2011) and the 2nd
National Conference on Electronic, Atomic, Molecular and Photonic Physics
(CEAMPP2011), 21st – 25th June 2011, Belgrade, Serbia, Contributed Papers & Abstracts of
Invited Lectures, Editors: Aleksandar R. Milosavljević, Saša Dujko and Bratislav P.
Marinković, Abstract of Poster Contributions p.69.

ISBN: 978-86-82441-32-8

Acknowledgements: MES Serbia (# 171020), Spanish MCIP (#FIS2009-10245), COST
ECCL and COST nano-IBCT.

14 J. B. Maljković, F. Blanco, G. García, B. P. Marinković and A. R. Milosavljević,
“Relative differential cross sections for elastic electron scattering by furan”,
Proc. XXI European Conf. on the Atomic and Molecular Physics of Ionized Gases (XXI
ESCAMPIG), 10 – 14 July 2012, Viana do Castelo, Portugal, European Conference Abstracts
Vol. 36A Editors: P.G.C. Almeida, L. L. Alves and Vasco Guerra, Poster contribution P2.1.4.
ISBN: 2-914771-74-6

ЗБОРНИЦИ СКУПОВА НАЦИОНАЛНОГ ЗНАЧАЈА

M 61

1. J. B. Maljković, A. R. Milosavljević, D. Šević and B. P. Marinković,
“Merenje apsolutnih diferencijalnih preseka za elastično rasejanje elektrona na malim
biomolekulima”,

Zbornik radova “*Fizika 2010 BL*”, Banja Luka, Republika Srpska, BiH, 22-24 septembar
2010. Urednik: B. Predojević, (PMF, Studijki program fizika, Banja Luka, 2011), Sekcijsko
predavanje *Sudari elektrona sa atomima i molekulima*, str. 201 – 210.

“Measurements of differential cross sections for elastic electron scattering by small
biomolecules”, (in Serbian)

Proceedings “*Physics 2010 BL*”, Banja Luka, Republic of Srpska, BiH, 22-24 September
2010. Ed. B. Predojević, Oral presentation within the section *Electron Scattering by Atoms
and Molecules*, pp.201 – 210.

Acknowledgements: grant 141011 as well as EU/ESF COST CM0601 “Electron Controlled Chemical Lithography” (ECCL) and MP1002 “Nano-scale Insights in Ion Beam Cancer Therapy (Nano-IBCT). Personal acknowledgements to F. Blanco and G. García.

ISBN: 978-99955-21-21-9

<http://www.fizika.rs.ba/Physics2010BL/sr/index.html>

M63

1. A. R. Milosavljević, J. B. Maljković, D. Šević, I. Čadež, and B. P. Marinković, “Kinetic energy distribution of positive ions from electron induced dissociative ionization of pyrimidine molecule”

Proc. The First Physics Congress of Bosnia and Herzegovina, 20 – 22. Dec. 2008, Teslić, Republic of Srpska, B&H, Book of Abstracts, Eds. D. Mirjanić, D. Milosević, and B. Predojević, Contributed Papers, Section 2 – Atomic, Molecular and Optical Physics, p.32.

2. J. B. Maljković, A. R. Milosavljević, F. Blanco, D. Šević, G. García and B. P. Marinković, “Relative Angle-Differential Cross Sections for Elastic Scattering of Electrons from 3-hydroxy-tetrahydrofuran Molecule”,

Proc. 1st National Conference on Electronic, Atomic, Molecular and Photonic Physics, 15-18 May 2008, Zaječar, Serbia, Book of Contributed Papers and Abstracts of Invited Lectures and Progress Reports, Eds. A. R. Milosavljević, D. Šević and B. P. Marinković, (Institute of Physics, Belgrade 2008) ISBN: 978-86-82441-22-9, Contributed Paper, pp.37-41.

<http://uranus.phy.bg.ac.rs/~ceampp/>

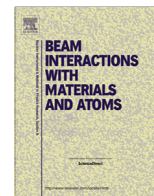

Study of electron transmission through a platinum tube



A.R. Milosavljević^{a,*}, M.Lj. Ranković^a, D. Borka^b, J.B. Maljković^a, R.J. Berezcky^c, B.P. Marinković^a, K. Tőkési^c

^a Institute of Physics Belgrade, University of Belgrade, Pregrevica 118, 11080 Belgrade, Serbia

^b Vinča Institute of Nuclear Sciences, University of Belgrade, P.O. Box 522, 11001 Belgrade, Serbia

^c Institute for Nuclear Research, Hungarian Academy of Sciences, H-4001 Debrecen, Hungary

ARTICLE INFO

Article history:

Received 18 July 2014

Received in revised form 21 November 2014

Accepted 26 November 2014

Available online 15 December 2014

Keywords:

Electrons

Transmission

Platinum capillary

ABSTRACT

We have measured 200 eV electron transmission through a single platinum tube of a diameter of 3.3 mm. We find that the transmission of electrons can be detected even at large tilt angles, where the tube is not transparent geometrically. The transmission drops down exponentially with increasing the tilt angle. The energy spectrum of detected electrons behind the tube contain contributions at lower energies due to both inelastic scattering and secondary electron emission. The spectrum is qualitatively in good agreement with the calculations performed for the flat Pt surface in order to understand and model the electron interaction processes that define the transmission and the energy spectrum at the exit.

© 2014 Elsevier B.V. All rights reserved.

1. Introduction

There has been a large interest in recent years to investigate transmission of low-energy electrons (up to 1 keV) through nano(-micro) capillaries made of insulating materials. This investigation was triggered by the highly charge ions (HCI) *guiding* phenomenon, which was first discovered by Stolterfoht and coauthors in 2002 [1]. The HCI guiding is well explained presently and is based on the fact that the beam of charged particles dynamically deposits charge on the inner capillary surface, thus forming a Coulomb field that deflects the forthcoming particles (preventing close interaction with the surface) and efficiently guides them towards the capillary exit. A large number of papers have been published so far on this phenomenon, which offers possibilities both to study fundamental particle–surface interaction processes and to develop interesting applications such as HCI beam for nanometer-scale fabrication and MeV proton microbeams for irradiating single cells [2,3]. A comprehensive review on the subject can be found in the recent paper by Lemell et al. [4].

The first studies on electron guiding through insulating capillaries have been reported in 2007 [5,6], and followed by more detailed investigations [7–9]. The electron transmission through the capillaries appears to be fundamentally different from the simple picture of HCI guiding governed solely by Coulomb deflection

[8,9]. Beside the Coulomb interaction that can also exist (although not necessary repulsive, but rather attractive due to the secondary electron emission [9]), electrons can be both elastically and inelastically scattered upon close interaction with the surface (primary projectiles) and can produce secondary electrons. Note also that electrons cannot change their charge state (in contrast to HCI), therefore it is impossible to distinguish between original and scattered projectiles. Moreover, since the dominant process upon electron transmission may be elastic electron–surface scattering, it has been suggested that even metallic (conductive) capillaries may be used for the electron guiding [8]. Following this idea, we have recently started an investigation on electron transmission through single metallic capillaries. The aim of the research is to learn about fundamental properties of both the electron guiding by metallic capillaries and the processes of electron–surface interaction that define guiding properties, as well as to investigate possible applications.

In the present paper, we report the study on the transmission of 200 eV incident electrons through a single Pt macrocapillary (3.3 mm diameter and 40.8 mm length – the aspect ratio of about 12.4). A large-diameter tube has been used, therefore the obtained results can be tested and analyzed according to the calculations made for the electron scattering by a flat Pt surface (which is more trivial), whereas the tube aspect ratio is large enough to test electron transmission at large tilt angles. The intensity of the outgoing electron current has been measured as a function of both the incident beam angle with respect to the capillary axis (the tilt angle) and the kinetic energy of outgoing electrons.

* Corresponding author.

E-mail address: vraz@ipb.ac.rs (A.R. Milosavljević).

2. Experiment

The experiment has been performed at the Institute of Physics Belgrade. The experimental system has been already described in detail elsewhere [5,7]. Additional small modifications have been made for the present study. A schematic view of the experimental setup is given in Fig. 1(a).

The system consists of an electron gun, a Pt tube attached to a 4-electrode electrostatic lens, a double cylindrical mirror analyzer (DCMA) followed by a single channel multiplier (channel-tron) and a Faraday cup. Fig. 1(b) shows the realistic model of the Pt tube fitted in the 4-electrode lens, as well as electric field distributions for typically used electrode voltages, made in SIMION program [10]. Note that a penetration of the electric field inside the Pt tube, thus possible influence to electron transmission, is negligible.

The electron gun produces a well collimated electron beam with an energy spread of about 0.5 eV, which is directed into a Pt tube of 3.3 mm diameter and 40.8 mm length (the aspect ratio of about 12.4). The angle between the incident electron beam direction and the tube axis, referred as the tilt angle, can be adjusted by rotating the electron gun. At the tilt angle of 90°, the electron beam is directed into the Faraday cup, which is attached to an

X–Y manipulator allowing the measuring of both the incident electron current intensity and the beam profile. The characteristic parameters of the electron beam – the diameter and the pencil angle (divergence) – are retrieved according to the simulated profile (for the identical geometry) where these parameters are adjusted to have the best fit to the experimental points. Fig. 1(c) shows a typical beam profile measured at 200 eV and the corresponding simulated curve obtained with a diameter of 0.9 mm and a divergence of 0.3°. Therefore, the incident electron beam is very well collimated and enters the Pt tube without losses.

The energy of electrons escaping the backside of the tube was analyzed using the DCMA working in a constant pass-energy mode – therefore, the count rates were recorded as a function of the retarding potential (V_R in Fig. 1(a)). It should be noted that this mode of operation provides a constant overall energy resolution, which was about 1 eV (full width at half maximum-FWHM), as measured in the elastic peak. However, the transmission of the entrance 4-electrode lens depends on the retarding potential. Therefore, the recorded kinetic electron energy distributions were corrected according to the transmission function estimated by electron ray-tracing simulations made in SIMION program [10]. The base pressure in the experimental chamber was about 7×10^{-7} mbar.

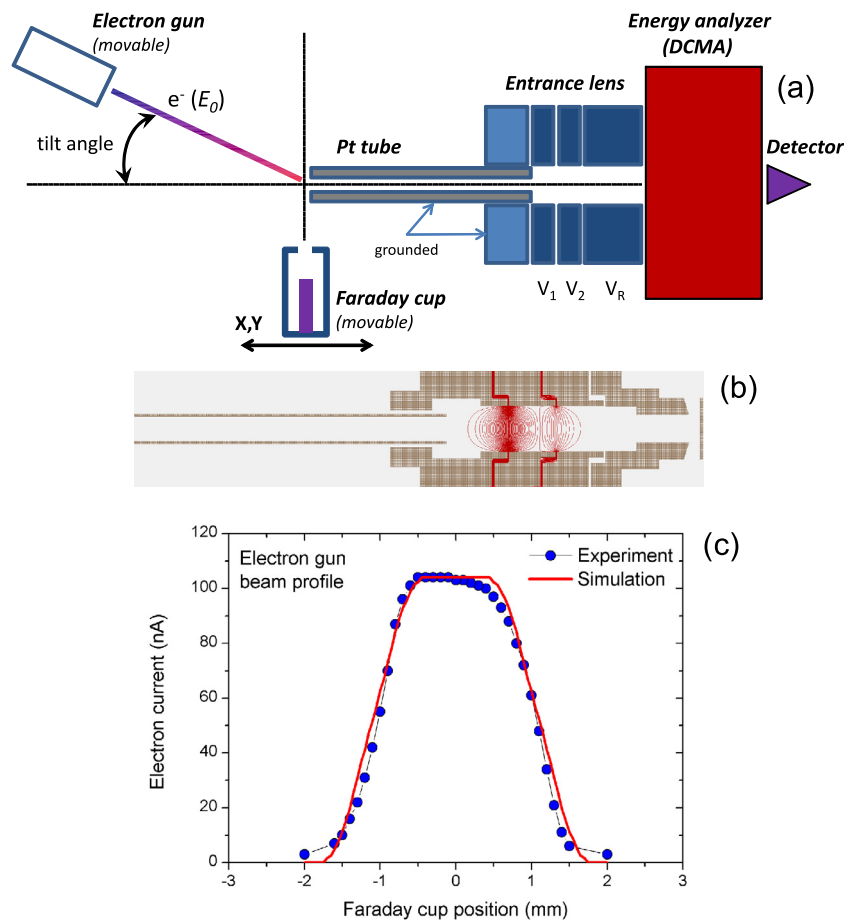

Fig. 1. (a) Experimental setup used in the present work. Electrons produced by the rotatable electron gun are directed into a Pt tube. Electrons escaping the tube are energy-analyzed. The intensity of the incident electron current and the electron beam profile are measured by using a movable Faraday cup with an entrance hole of 2 mm. (b) The realistic model of the Pt tube fitted in the 4-electrode lens made in SIMION program. The distribution of the electric field for electrode potentials typically used in the experiment are shown by red lines. (c) The 200 eV electron beam profile measured by the Faraday cup (blue circles) and the corresponding SIMION simulation (red line) obtained with the parameters: diameter = 0.9 mm; pencil angle = 0.3°. (For interpretation of the references to color in this figure legend, the reader is referred to the web version of this article.)

3. Electron–surface scattering calculations

We also present calculated kinetic energy spectra of 200 eV electrons scattered from a flat Pt surface. Calculation is performed using Monte Carlo Simulation (MCS) of low energy electrons backscattered from platinum (Pt) surface [11]. In this simulation we take into account both elastic and inelastic collisions. For elastic collisions of electrons by Pt atoms, we use static field approximation with non-relativistic Schrödinger partial wave analysis [12].

For the case of inelastic scattering we use a dielectric response formalism [13–16]. According to the dielectric theory, a dielectric function $\epsilon(q, \omega)$ describes the response of a medium, as an assembly of interacting electrons and atoms, to the disturbance from an external point charge. The dielectric function $\epsilon(q, \omega)$ is the momentum (q) and energy (ω) dependent. The energy loss function $Im(-1/\epsilon(q, \omega))$, determines the probability of such an event. For the case of bulk material the energy loss function is given by the relation $Im(-1/\epsilon(q, \omega))$ and in the case of a surface it is given by the relation $Im(-1/(\epsilon(q, \omega) + 1))$. For low energies, like in the present case, it is more convenient to use the surface energy loss function. The dielectric function for Pt is obtained from Refs [17,18].

We have performed MCS and calculated the backscattered electron energy loss distributions for primary and secondary electrons. Details about calculation can be found in papers [11,19] and in references there in.

4. Results and discussion

Fig. 2(a) presents a typical dependence of the detected count rate of the electrons escaping the Pt tube without an energy loss on the tilt angle. In order to avoid a saturation of the channeltron at small tilt angles, the incident current intensity was reduced to below 1 nA (such low electron currents were not measurable with the present setup). The measurements show a very narrow angular distribution of the detected electron current, which practically corresponds to the primary electron beam. Note that the aspect ratio of the Pt tube defines the maximum acceptance angle of 4.6° . Therefore, the measured angular distribution presented in Fig. 2(a) is also influenced by the electrostatic field (i.e. the focal properties of the lens – in the present case, the focus was on the elastic channel), as well as the transmission of the whole analyzer system, including the 4-element entrance lens, the double cylindrical mirror analyzer and a 3-element lens placed at the exit (see [20] for details).

Clearly, at low incident electron currents only the direct beam is detected, therefore the scattered (guided) electrons cannot be measured and studied. Still the measurements presented in Fig. 2(a) are important for the adjustment of the incident electron beam profile and the calibration of the angular scale.

In order to test a possibility of electrons being directed along the capillary axis due to the close interaction with the inner walls, as well as to measure the kinetic energy distribution of scattered electrons, the electron gun was positioned at large tilt angles and the incident electron current was increased to about 100 nA (as measured in the Faraday cup – see Fig. 1(b)). Fig. 2(b) presents a kinetic energy distribution of electrons escaping the tube at the incident energies or with small energy losses (up to about 8 eV). Clearly, the elastic peak can be detected even at very large tilt angles above the maximum value of 4.6° as defined by the tube aspect ratio. As expected, the intensity of the transmitted (guided) electron current strongly decreases with increasing the tilt angle; the dependence is practically exponential (see the inset in Fig. 2(b)). Since the incident beam direction is far from the capillary acceptance angle, the measured signal of electrons escaping the capillary at incident energies (200 eV) must be due to the elastic

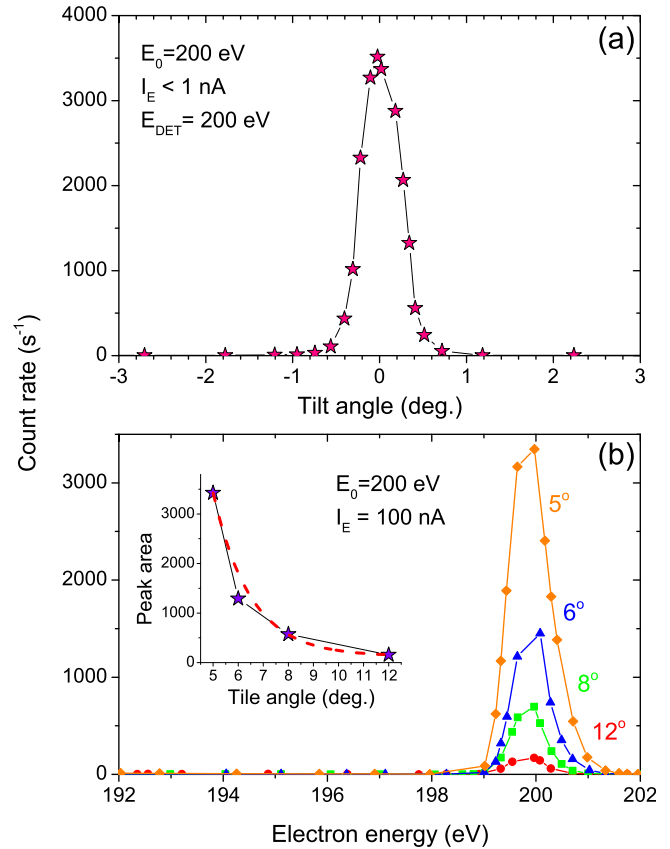

Fig. 2. (a) The intensity of the electron current escaping the Pt tube at the energy of 200 eV, as a function of the tilt angle, for the incident electron energy of 200 eV and the incident electron current intensity lower than 1 nA. (b) Experimentally obtained kinetic energy spectra of electrons escaping the Pt tube, for the incident electron energy of 200 eV, the incident electron current intensity of 100 nA and the tilt angles of 5 (diamonds), 6 (triangles), 8 (squares) and 12 (circles) degrees. The inset shows the area of the peaks presented in (b), in the energy domain from 198 to 202 eV, as a function of the tilt angle. The red curve represents the exponential decay fit to the experimental points. (For interpretation of the references to color in this figure legend, the reader is referred to the web version of this article.)

electron scattering from the Pt capillary surface, thus enabling the transmission along the axis.

The close electron interaction with the inner Pt surface should also lead to both inelastic scattering and secondary electrons emission. Therefore, in contrast to the HCI guiding by insulating capillaries provided by Columbic mirror, a very broad kinetic energy distribution of escaping electrons is expected. A typical distribution obtained at the tilt angle of 6° and with the incident electron energy of 200 eV, is presented in Fig. 3(a), in a broad energy domain down to 50 eV. Apart from the sharp elastic peak that corresponds to the dominant fraction of the transmitted electrons, there is a large number of electrons at lower energies.

Fig. 3(b) shows the calculated kinetic energy distribution of electrons upon scattering of 200 eV incident electron beam from a plane Pt surface at an angle of 6° (it should be noted that the calculated distribution is not strongly dependent on the incident beam angle). The theoretical curves also separately present the yield of both the primary (due to elastic and inelastic scattering) and the secondary electrons, down to the energy of 80 eV. The experimental results are compared with the calculations by normalizing the measured curve at the energy of 185 eV. There is a good qualitative agreement between the theory and the experiment, particularly in the energy domain down to about 170 eV. Moreover, the constant increase of the secondary electrons yield as their energy decreases is also in agreement with the trend found

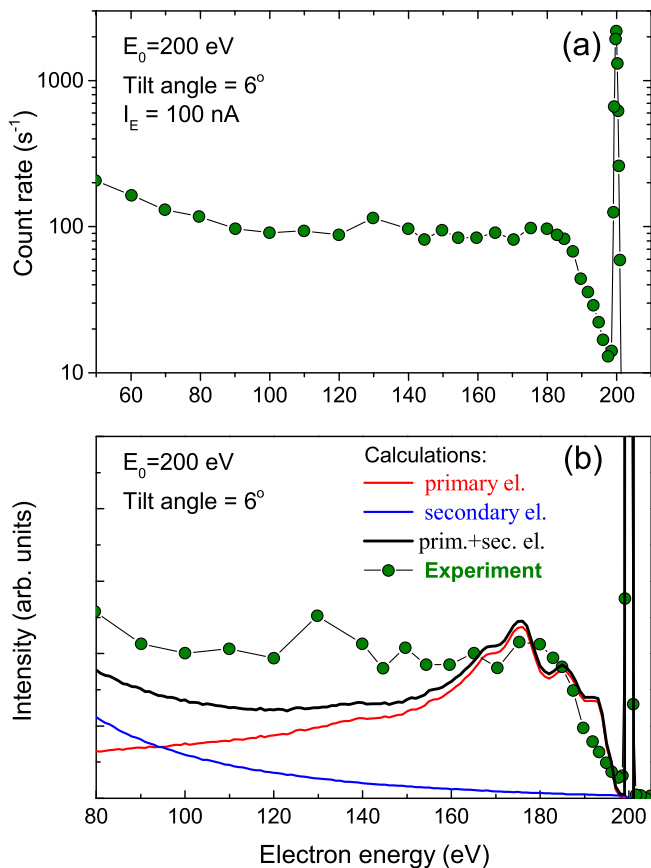

Fig. 3. (a) Experimentally obtained kinetic energy spectrum of electrons escaping the Pt tube, for the incident electron energy of 200 eV, the incident electron current intensity of 100 nA and the tilt angle 6°. (b) Calculated kinetic energy spectra of electrons scattered from a flat Pt surface, for the incident electron energy of 200 eV and the scattering angle of 6°. The experimentally obtained kinetic energy spectrum of electrons escaping the Pt tube, for the incident electron energy of 200 eV is normalized at 185 eV.

in the experiment. However, the calculated curve appears to be more structured, with pronounced shoulders, which cannot be resolved in the measured electron energy spectrum. Also, although both energy distributions are characterized by a pronounced elastic peak, the inelastic/elastic ratios are different.

The disagreement between the calculated and the measured spectra can be due to several reasons. The calculations were performed for a flat surface (to the best of our knowledge, there are no experimental results for a flat Pt surface), while in the experiment the electrons interact with the capillary surface and can suffer multiple scattering events before reaching the capillary exit and being detected. Therefore, this multiple scattering (including inelastic scattering of inelastically scattered projectiles) can smear out the respective structures seen in the theoretical spectrum. Furthermore, although the experimental spectrum has been corrected for the transmission function, the real transmission may be somewhat different from the calculated one that is based on an ideal uniform beam leaving the Pt tube and takes into account only the entrance electrostatic lens. It should be also taken into account that, in contrast to the theoretical case, the Pt surface in the experiment may be polluted from the adsorbed residual gas in the vacuum chamber. Finally, there is also an uncertainty of the calculated spectrum, dominantly because we have used a dielectric function for Pt that has been obtained by fitting the experimental results. It has been found in the present work that the calculated energy spectra were sensitive to the applied dielectric functions. However, overall, there is a good accordance between the experiment and

the calculations, suggesting that the theory can be used to predict and select good candidates as materials to be used for electron transport by metallic capillaries.

5. Conclusion

In summary, we have presented a joint experimental and theoretical study on 200 eV electron transmission through a single platinum tube. We find that the transmission of electrons at their incident energies can be detected even at large tilt angles, where the tube is not transparent geometrically. The transmission drops down exponentially with increasing the tilt angle. The energy spectrum of detected electrons behind the tube contain contributions at lower energies due to both inelastic scattering and secondary electron emission. The spectrum is qualitatively in good agreement with the calculations performed for the flat Pt surface in order to understand and model the electron interaction process that define the transmission and the energy spectrum at the exit.

Although more studies with micro and nano capillaries should be performed, the present results suggest a possibility of using metallic capillaries to investigate fundamental properties of a conductive material inside a high aspect ratio pores, by use of the electron spectroscopy under ultra-high vacuum conditions. Moreover, there are potentials for interesting applications, such as the use of nano and micro high-aspect ratio metallic capillaries as a robust, spatially well-determined low-energy electron source/transporter. This could be applied, for example, to study electron driven molecular processes under different environmental conditions.

Acknowledgments

The work was supported by the Ministry of education, science and technological development of Republic of Serbia under the Grants OI 171020 and 45005, by the Hungarian SRF OTKA No. NN 103279, and by the Bilateral Cooperation Program between the Hungarian and Serbian Academies. This work was conducted within the framework of the COST Action CM1301 (CELINA).

References

- [1] N. Stolterfoht, J.-H. Bremer, V. Hoffmann, R. Hellhammer, D. Fink, A. Petrov, B. Sulik, *Phys. Rev. Lett.* 88 (2002) 133201.
- [2] T. Ikeda, Y. Kanai, T.M. Kojima, Y. Iwai, T. Kambara, Y. Yamazaki, M. Hoshino, T. Nebiki, T. Narusawa, *Appl. Phys. Lett.* 89 (2006) 163502.
- [3] T. Ikeda, T.M. Kojima, T. Kobayashi, W. Meissl, V. Mckel, Y. Kanai, Y. Yamazaki, *J. Phys. Conf. Ser.* 399 (2012) 012007.
- [4] C. Lemell, J. Burgdörfer, F. Aumayr, *Prog. Surf. Sci.* 88 (2013) 237.
- [5] A.R. Milosavljević, Gy. Víkor, Z.D. Pešić, P. Kolarž, D. Šević, B.P. Marinković, S. Mátéfi-Tempfli, M. Mátéfi-Tempfli, L. Piraux, *Phys. Rev. A* 75 (2007) 030901(R).
- [6] S. Das, B.S. Dassanayake, M. Winkworth, J.L. Baran, N. Stolterfoht, J.A. Tanis, *Phys. Rev. A* 76 (2007) 042716.
- [7] A.R. Milosavljević, J. Jureta, Gy. Víkor, Z.D. Pešić, D. Šević, M. Mátéfi-Tempfli, S. Mátéfi-Tempfli, B.P. Marinković, *Europhys. Lett.* 86 (2009) 23001.
- [8] K. Schiessl, K. Tókési, B. Solleder, C. Lemell, J. Burgdörfer, *Phys. Rev. Lett.* 102 (2009) 163201.
- [9] A.R. Milosavljević, K. Schiessl, C. Lemell, K. Tokési, M. Mátéfi-Tempfli, S. Mátéfi-Tempfli, B.P. Marinković, J. Burgdörfer, *Nucl. Instr. Meth. B* 279 (2012) 190.
- [10] D.J. Manura, D.A. Dahl, SIMION Version 8.0, User Manual, Scientific Instruments Services, Inc., 2007.
- [11] Z.-J. Ding, R. Shimizu, *Surf. Sci.* 222 (1989) 313.
- [12] F. Salvat, R. Mayol, *Comput. Phys. Commun.* 74 (1993) 358.
- [13] D. Pines, *Elementary Excitations in Solids*, Benjamin, New York, 1964. p. 127.
- [14] H. Ritchie, *Phys. Rev.* 106 (5) (1957) 874.
- [15] H. Ritchie, A.L. Marusak, *Surf. Sci.* 4 (1966) 234.
- [16] F. Salvat-Pujol, W.S.M. Werner, *Surf. Interface Anal.* 45 (2013) 873.
- [17] W.S.M. Werner, K. Glantschnig, C. Ambrosch-Draxl, *J. Phys. Chem. Ref. Data* 38 (4) (2009).
- [18] W.S.M. Werner, private communications.
- [19] Z.-J. Ding (Ph.D. thesis), Osaka University, 1990.
- [20] A.R. Milosavljević, S. Madžunkov, D. Šević, I. Čadež, B.P. Marinković, *J. Phys. B: At. Mol. Opt. Phys.* 39 (2006) 609.

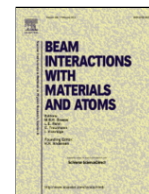

Electron transmission through a steel capillary

J.B. Maljković^a, D. Borka^b, M. Lj. Ranković^a, B.P. Marinković^{a,*}, A.R. Milosavljević^c, C. Lemell^d, K. Tőkési^e

^a Institute of Physics Belgrade, University of Belgrade, Pregrevica 118, 11080 Belgrade, Serbia

^b Atomic Physics Laboratory (040), Vinča Institute of Nuclear Sciences, University of Belgrade, P.O. Box 522, 11001 Belgrade, Serbia

^c Synchrotron SOLEIL, L'orme des Merisiers, Saint-Aubin – BP48, 91192 GIF-sur-Yvette Cedex, France

^d Institute for Theoretical Physics, Vienna University of Technology, Wiedner Hauptstraße 8-10, A-1040 Vienna, Austria

^e Institute for Nuclear Research, Hungarian Academy of Sciences (ATOMKI), H-4026 Debrecen, 4026 Debrecen Bem tér 18/c, Hungary

ARTICLE INFO

Keywords:

Electron scattering from surfaces
Capillary transmission
Metallic capillary
Energy loss

ABSTRACT

The transmission of low-energy electrons through a macroscopic steel capillary has been investigated both experimentally and theoretically. The length of the steel capillary was $L = 19.5$ mm and the inner diameter was $d = 0.9$ mm. The kinetic energy distribution of electrons transmitted through the steel capillary was recorded for a tilt angle of $\psi = 2.6^\circ$ of the incident electron beam with respect to the capillary axis. Accompanying simulations based on classical transport theory reproduce the experimental data to a high degree of agreement. Transmission for other tilt angles has also been simulated to investigate the influence of the tilt angle on the guiding efficiency.

1. Introduction

The understanding and interpretation of electron spectra backscattered from solid surfaces is important for many technical applications, e.g., for surface characterization and diagnostics to assess material damage and surface modification [1–4]. Additionally, analysis of particles scattered off solid surfaces allows for studying the scattering process itself.

With the advent of capillary targets [5,6] the change of the internal state of the (ionic) projectiles due to the close interaction with the inner capillary wall have become topics of research, since 2002 the redirection of charged particles by nanocapillary targets (see [7,8] and references therein) was investigated in detail.

In our experiment we study electrons escaping macroscopic metallic capillaries after (multiple) impact on the inner wall of the target. Deflection of incident electrons along the capillary axis is accompanied by both elastic and inelastic scattering events and the production of secondary electrons with considerable energy loss of the projectile [9–12]. Clearly, an experimental distinction between transmitted primary particles and secondary electrons generated in inelastic scattering events remains impossible and requires extensive simulations of the transmission process [13–15].

In this work we study the transmission of 150 eV electrons through a macroscopic steel capillary and model the experiment based on classical transport theory [16–19]. The theoretical spectra are presented in the energy range between 60 eV and 150 eV. For smaller electron energies calculated cross sections become unreliable.

2. Experiment

The experiment was performed on the electron spectrometer UGRA (Institute of Physics Belgrade) which has been modified to allow for mounting of a capillary target [12] instead of a gas needle. The experimental set-up is shown in Fig. 1.

The system consists of a rotatable electron gun, steel capillary, 4-electrode lens, double cylindrical mirror energy analyzer (DCMA), 3-electrode lens, channeltron as a detector and a Faraday cup for obtaining the incident electron beam profile. All components are electrically shielded and enclosed in a vacuum chamber which is magnetically shielded with two layers of μ metal. The working pressure in the experimental chamber during the measurements was about 7×10^{-7} mbar. The electron energy resolution of the system is about 0.7 eV at full width half maximum. The electron gun produces a well collimated electron beam which is directed on the capillary target.

* Corresponding author.

Email address: bratislav.marinkovic@ipb.ac.rs (B.P. Marinković)

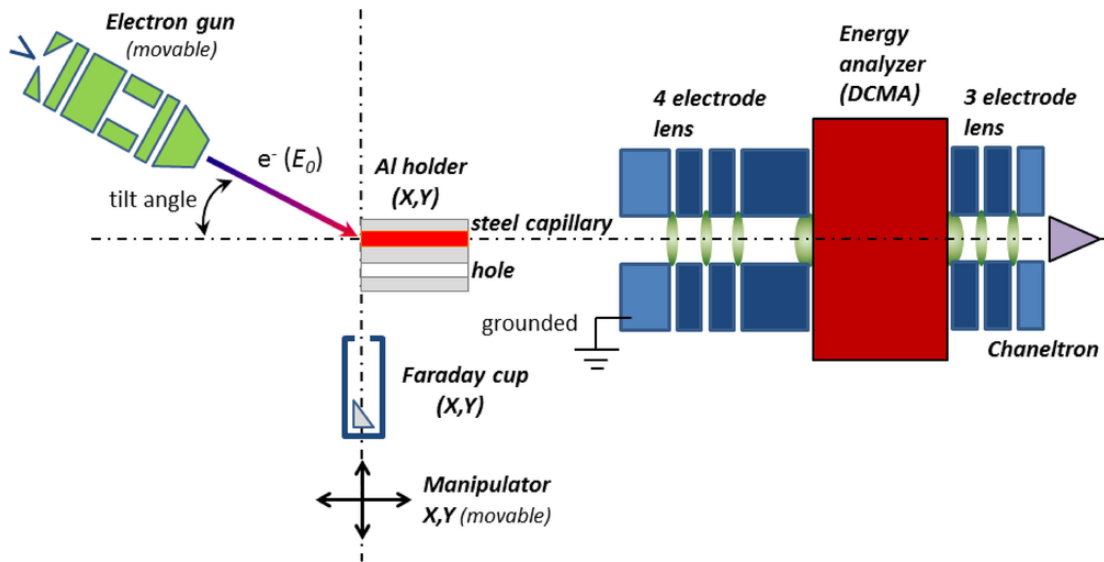

Fig. 1. The experimental set-up UGRA with the movable electron gun, stainless steel capillary, manipulator and double cylindrical mirror energy analyzer with a detector. The analyzer optics and detector are fixed in place. The X - Y manipulator is used to mount either a Faraday cup prior to experiment or an aluminum target holder with the capillary during the experiment.

To align the experimental components and to measure the electron beam profile, a Faraday cup was mounted on X - Y manipulator as indicated in Fig. 2. After optimizing and focusing the electron optics for 150 eV energy, the electron beam profile was measured by recording the current in the Faraday cup as a function of the rotation angle Θ_{relative} within the range of about $\pm 4^\circ$ relative to the Faraday cup axis. The Faraday cup was set at a distance of 55 mm from the last electrode of the electron gun.

In order to estimate electron beam width and divergence, a SIMION simulation [20] with the real experimental electrode geometry was performed. In this simulation, starting conditions of electron trajectories were characterized by two parameters, the electron beam width w and the angular divergence da . Initial conditions were uniformly dis-

tributed within w and da . The transmission function $T(w, da)$ was simulated for different combinations of w and da until the best agreement between experimental result and simulated data was achieved (Fig. 3). From the comparison we estimated the beam divergence to be 0.3° and a beam diameter of 0.82 mm at the exit of the electron gun.

For the experiment the Faraday cup was replaced by a steel capillary with a diameter of 0.9 mm and a length of 19.5 mm. It has an aspect ratio of 21.7 or, equivalently, a geometric opening angle of 2.6° . The vertical distance between the capillary and a hole was 5.8 mm, while distance between the capillary entrance and last electron gun lens was about 25 mm. The capillary position was adjusted to align with the incident electron beam and the energy analyzer axis. The tilt angle between the incident electron beam and the capillary axis is ad-

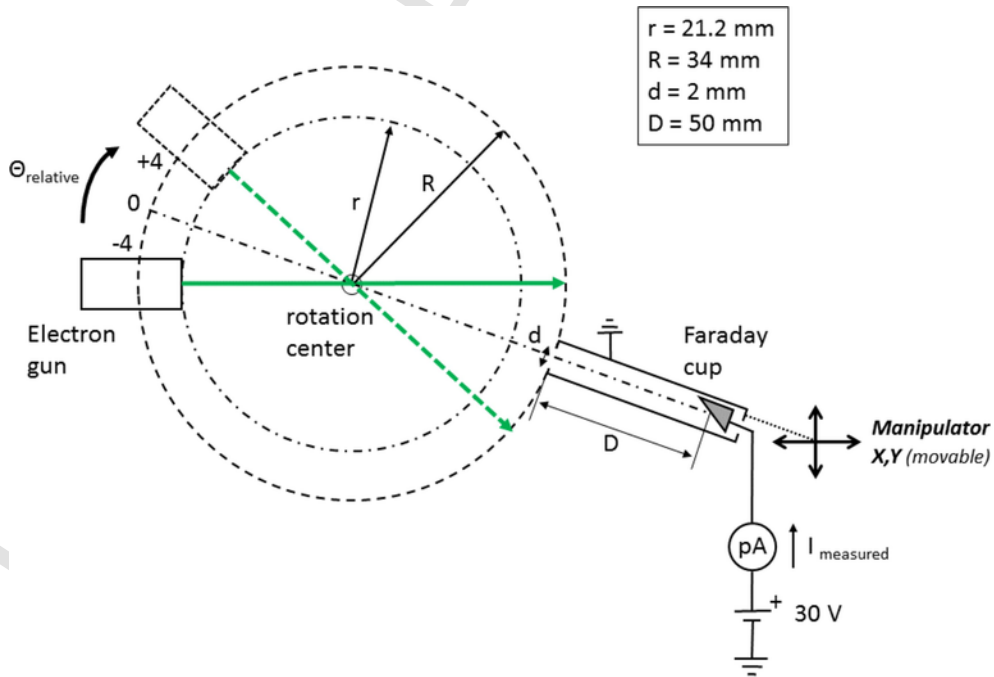

Fig. 2. Schematic representation of setup for measuring the electron beam profile.

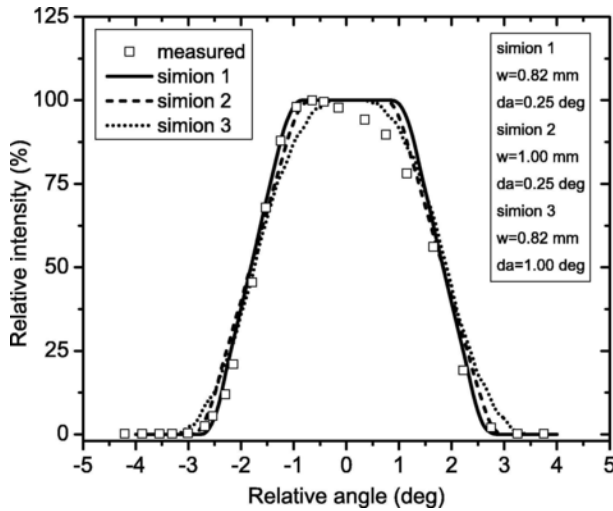

Fig. 3. Measured and simulated electron beam profiles. Symbols: measured profile, lines: SIMION simulations with different parameters; solid line – $w = 0.82$ mm, $da = 0.25^\circ$, dash line – $w = 1.00$ mm, $da = 0.25^\circ$, dot line – $w = 0.82$ mm, $da = 1.0^\circ$.

justed by rotating the electron gun with the capillary and analyzer remaining fixed.

The system allows for measurements of the transmitted electron current as a function of both the tilt angle and the kinetic energy of electrons escaping the capillary [12]. The electrons transmitted through the steel capillary were energy analyzed by the DCMA operating in constant pass energy mode with counts recorded as a function of a retarding potential. As the transmission of the 4-electrode lens depends on the retarding potential energy distributions of transmitted electrons were corrected according to the transmission function obtained by SIMION. An optimal system alignment was verified by measuring the total transmitted electron current at the inner cylinder of the DCMA.

3. Theory

In our simulation stainless steel is approximated with iron by neglecting any admixtures (Cr, O, C) of unknown quantity. Both elastic and inelastic collisions in Fe are taken into account. Energy dependent cross sections for elastic scattering off Fe atoms modeled with muffin-tin potential were calculated using non-relativistic Schrödinger partial wave analysis [21].

For the description of inelastic scattering cross sections we rely on the dielectric response formalism [22]. Accordingly, the momentum- and energy-loss dependent dielectric function $\epsilon(q, \omega)$ can be approximated by extrapolation of optical data $\text{Im}[-\epsilon(q=0, \omega)^{-1}]$ into the $q - \omega$ plane. Then, the bulk and surface energy loss functions are given by $\text{Im}[-\epsilon(q, \omega)^{-1}]$ and $\text{Im}[-\{\epsilon(q, \omega) + 1\}^{-1}]$, respectively [28,29]. The analytical expression given by the Lindhard [36] dielectric function provides a convenient framework for the dielectric properties of Fe. Here, surface and bulk dielectric functions were obtained following Werner et al. [37,38] (see Fig. 4).

Within the capillary electrons follow straight line trajectories. Upon impact on the inner wall of the capillary projectiles undergo a sequence of stochastic scattering events determined by the elastic and inelastic mean free paths. If an electron eventually reescapes from the inner capillary surface the next impact point on the opposite side of the capillary or its escape point from the capillary is calculated. In case of an inelastic scattering event a secondary electron is created with a kinetic energy equal to the energy lost by the primary particle. The initial direction of the secondary electron is chosen randomly from 4π . If

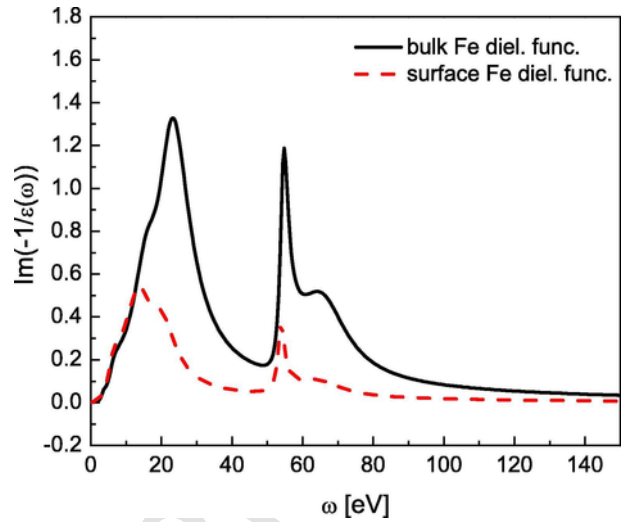

Fig. 4. Bulk (thick solid black line) and surface (thin dashed red line) dielectric functions of Fe [37]. (For interpretation of the references to colour in this figure legend, the reader is referred to the web version of this article.)

its initial kinetic energy is larger than 60 eV its trajectory is subsequently followed as well.

4. Results and discussion

In our experiment we selected the smallest angle for which all projectiles have to interact with the inner wall of the capillary, i.e., an angle slightly larger than the geometric opening angle of the capillary. With the linear dimensions of our target capillary (diameter $d = 0.9$ mm, length $L = 19.5$ mm) the tilt angle in the experiment was set to $\psi = 2.6^\circ$. Geometrically, the dominant fraction of electrons are expected to hit the inner surface of the capillary only once. Assuming specular reflection conditions and accounting for a beam divergence of 0.3° more than 75% are expected to undergo only one impact event, another $\sim 20\%$ two impact events (Fig. 5).

From the general shape of the surface and bulk dielectric loss functions (rather broad and featureless functions, Fig. 4) and the small number of impact events we expect the energy distribution of transmitted electrons to resemble the usual energy distributions after backscattering from plane solid surfaces: a sharp elastic peak together with a broad distribution of projectiles having lost a considerable fraction of their initial energy. Towards smaller energies the admixture of secondary electrons increases. Fig. 6 shows our experimental results for 150 eV electrons incident on a steel capillary under an incidence angle of 2.6° (symbols). In general, for small incidence angles one would expect the surface excitations to dominate inelastic scattering events and cause smaller energy loss. Here, however, a clear distinction between surface and bulk losses is not visible presumably due to the surface roughness of the inner wall of the capillary target accompanied by deep penetration into the target under an effectively larger incidence angle. Phonon excitations with energy losses less than about 0.1 eV will only appear as a slight broadening of the elastic peak but have not been analyzed in our experiment. The dominant loss peaks with maxima around 20 and 60 eV are the material characteristic energy losses of electrons in inelastic scattering events containing collective excitations (or plasmons) and single electron excitations. Due to the large number of d electrons in Fe the plasmon peak ($\hbar\omega_{pl} \approx 15.3$ eV) is submerged in the broad distribution around 20 eV (shoulder on the low-energy side of the distribution) and, consequently, cannot be singled out in the electron-energy spectrum as a solitary feature.

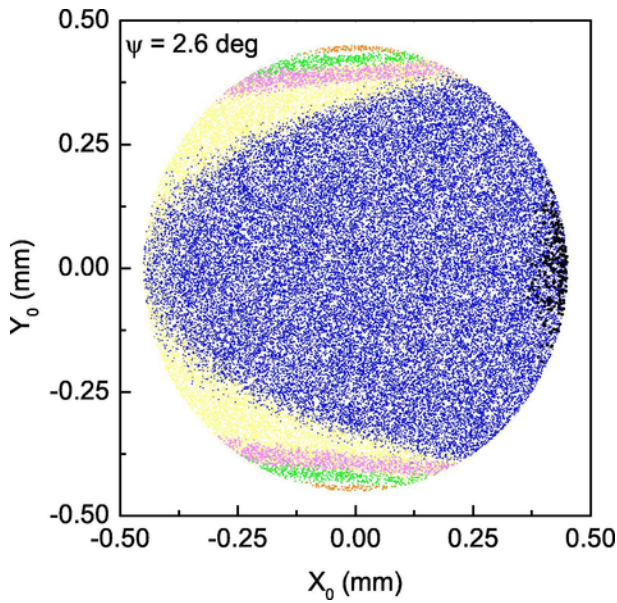

Fig. 5. Trajectories starting from randomly selected positions on the entrance plane under an incidence angle of $2.6 \pm 0.3^\circ$ with respect to the capillary axis are calculated assuming specular reflection upon impact on the inner capillary wall. The number of scattering events is shown in color (0: black 1: blue, 2: yellow, 3: green 4: pink, > 4: orange). (For interpretation of the references to colour in this figure legend, the reader is referred to the web version of this article.)

To identify surface- or bulk-loss channels we have performed simulations allowing only for surface excitations (thin blue line in Fig. 6) and also for bulk excitations only (thick red line in Fig. 6). Neither simulation run succeeds in perfectly reproducing the experimental results. It can, however, be clearly seen that surface excitation contributions are only responsible for a small fraction of inelastic energy losses. As stated above, this points to a large surface roughness shifting the weight from surface to bulk losses. Additionally, only a minority of electrons leave the surface under the angle of incidence as assumed in the specular reflection model. Therefore, trajectories with more than one impact on the surface will feature on average a larger effective impact angle. This becomes evident when comparing Fig. 5 with Fig. 7

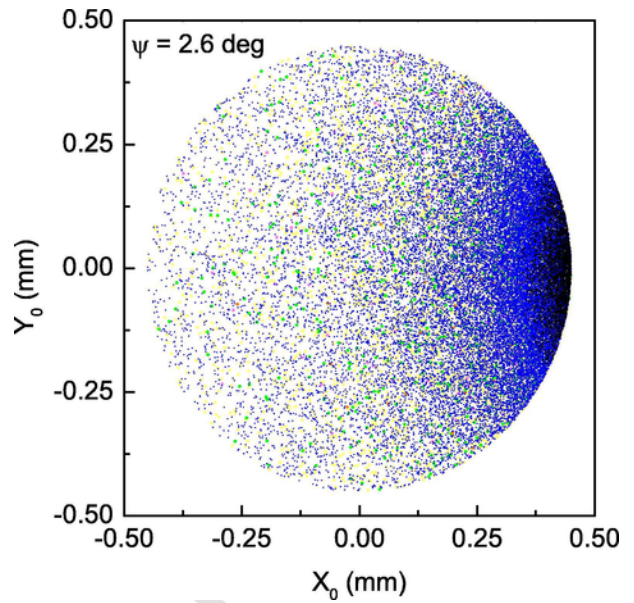

Fig. 7. Same as Fig. 5 but from results of the full simulation for an incidence angle of $\psi = 2.6 \pm 0.3^\circ$. (0: black 1: blue, 2: yellow, 3: green 4: pink, >4: orange). (For interpretation of the references to colour in this figure legend, the reader is referred to the web version of this article.)

which shows again the starting points of trajectories on the entrance plane.

The dominant fraction of transmitted electrons is still scattered only once but a more realistic description of the electron-wall interaction removes the boundaries between regions with different number of impact events due to an effective randomization of the exit angle from the inner capillary wall. This is also related to the neglected reflection at the collective potential of surface atoms [13] active at flat parts of the inner target wall for very grazing incidence angles. Both, the height of the elastic scattering peak in our simulation and the inelastic part of the spectrum is modeled very well.

Increasing the tilt angle in the simulations we have calculated the reduction of the transmission ratio of the capillary, i.e., number of electrons (including secondaries) divided by the number of trajectories started on the entrance plane of the capillary (Fig. 8). The energy and

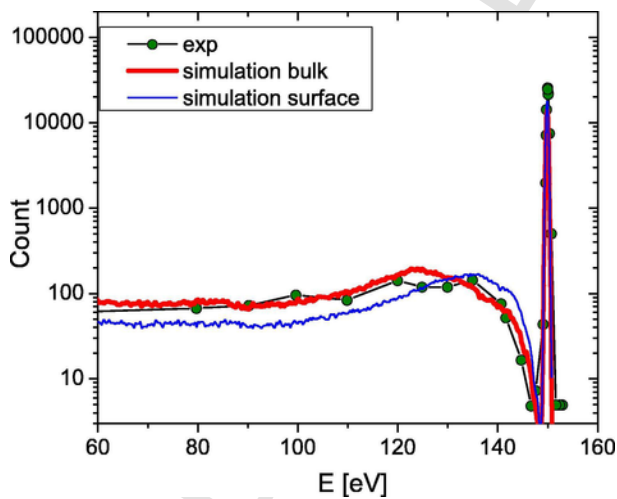

Fig. 6. Comparison between the experimentally obtained kinetic energy spectrum and calculated spectra of electrons escaping the steel tube, for an incident electron energy of 150 eV and electron beam incident angle $\psi = 2.6^\circ$. The simulated spectra have been obtained using the bulk dielectric function (thick red line) and the surface dielectric function (thin blue line) of iron. Experimental data are presented by green circles. (For interpretation of the references to colour in this figure legend, the reader is referred to the web version of this article.)

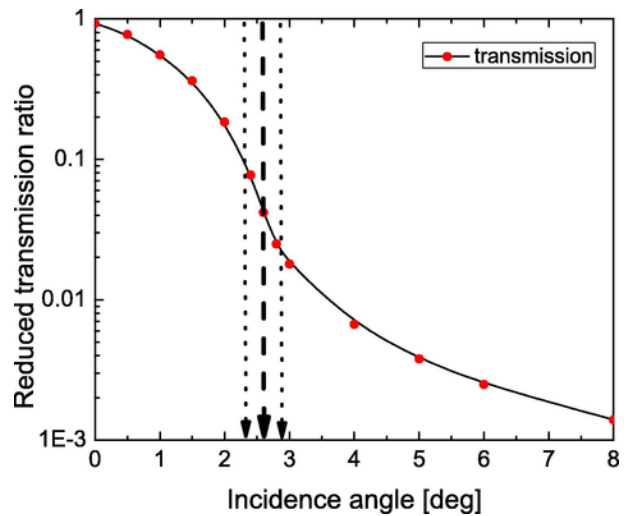

Fig. 8. Reduced transmission ratio as a function of incidence angle. The geometric opening angle is indicated by the dashed line, the beam divergence by the area between the dotted lines. Even at large incidence angles a considerable fraction of electrons are transmitted through the capillary.

incidence angle of simulated electrons were randomly picked from Gaussian distributions with $E_0 = 150$ eV, $\sigma_E = 0.5$ eV and $\sigma_\psi = 0.3^\circ$, respectively. Only electrons with kinetic energy larger than 50 eV were considered.

Two angular ranges can be discerned: as electrons hitting the surface have only a small probability to re-escape the surface the transmission ratio is for incidence angles smaller than the geometric angle dominated by transmission without interaction with the capillary wall. In contrast, for larger angles ($\psi > 3^\circ$) every projectile hits the surface at least once thereby considerably reducing the transmission probability. Note, however, that even at larger angles electrons may still be transmitted at the original energy of 150 eV. In our simulation from $\psi = 2.6^\circ$ to $\psi = 5^\circ$ the total transmission probability is reduced by almost an order of magnitude (not considering the increasing intensity of low-energy electrons not included in our simulation).

5. Conclusion

We have presented a joint experimental and theoretical investigation of electrons transmission through a steel capillary with 150 eV primary incident electron energy at $\psi = 2.6^\circ$ which is tilt angle of the capillary. The electron beam divergence was 0.3° . Theoretical spectra were obtained in the energy range between 60 and 150 eV. In the simulation both elastic and inelastic scattering of primary electrons colliding with the inner capillary surface as well as secondary electron emission from the capillary wall were taken into account.

From a comparison of experimental and simulated energy spectra we conclude that the inner wall of our capillary target was very rough suppressing to a large extent specular reflection and interaction with surface loss channels. Instead, best agreement between experiment and theory was found considering only bulk excitations in the simulation of inelastic scattering processes.

Furthermore, we have calculated the transmission ratio of electrons with energies ranging from 60 to 150 eV and found a slowly decreasing transmission function outside the geometric transmission range ($\psi > 3^\circ$). While in specular reflection approximation projectiles would have to undergo a large number of impact events for large ψ a realistic description of the surface interaction leads to a randomization of the scattering angle and, consequently, an increased number of trajectories having suffered only few impacts.

Uncited references

[23–27,30–35].

Acknowledgments

The work was supported by the Ministry of education, science and technological development of Republic of Serbia under the grants OI 171020 and III 45005. D.B. and C.L. acknowledge support by the bilateral

Austrian-Serbian project “Interaction of charged particles with capillaries” number 451-03-01039/2015–09/25, K.T. and C.L. by the *Stiftung Aktion Österreich-Ungarn* under Project No. 96öu9. K.T. acknowledges support by the National Research, Development and Innovation Office (NKFIH) Grant KH 126886. D.B. and K.T. acknowledge support by the European COST Actions CA15107 (MultiComp) and MP1306 (EUSpec).

References

- [1] T.L. Ferrell, P.M. Echenique, *Phys. Rev. Lett.* 55 (1985) 1526.
- [2] H. Cohen, T. Maniv, R. Tenne, Y. Rosenfeld Hacoen, O. Stephan, C. Colliex, *Phys. Rev. Lett.* 80 (1998) 782.
- [3] F.J. Garcia de Abajo, *Rev. Mod. Phys.* 82 (2010) 209.
- [4] W.S.M. Werner, M. Novák, F. Salvat-Pujol, J. Zemek, P. Jiricek, *Phys. Rev. Lett.* 110 (2013) 086110.
- [5] Y. Yamazaki, S. Ninomiya, F. Koike, H. Masuda, T. Azuma, K.-I. Komaki, K. Kuroki, M. Sekiguchi, *J. Phys. Soc. Jpn.* 65 (1996) 1199.
- [6] S. Ninomiya, Y. Yamazaki, F. Koike, H. Masuda, T. Azuma, K. Komaki, K. Kuroki, M. Sekiguchi, *Phys. Rev. Lett.* 78 (1997) 4557.
- [7] C. Lemell, J. Burgdörfer, F. Aumayr, *Prog. Surf. Sci.* 88 (2013) 237.
- [8] N. Stolterfoht, Y. Yamazaki, *Phys. Rep.* 629 (2016) 1.
- [9] A.R. Milosavljević, Gy. Vákor, Z.D. Pešić, P. Kolarž, D. Šević, B.P. Marinković, S. Mátéfi-Tempfli, M. Mátéfi-Tempfli, L. Piraux, *Phys. Rev. A* 75 (2007) 030901(R).
- [10] S. Das, B.S. Dassanayake, M. Winkworth, J.L. Baran, N. Stolterfoht, J.A. Tanis, *Phys. Rev. A* 76 (2007) 042716.
- [11] B.S. Dassanayake, R.J. Berezcky, S. Das, A. Ayyad, K. Tökési, J.A. Tanis, *Phys. Rev. A* 83 (2011) 012707.
- [12] A.R. Milosavljević, M. Lj, D. Ranković, J.B. Borka, R.J. Maljković, B.P. Berezcky, K. Tökési Marinković, *Nucl. Instrum. Methods Phys. Res. B* 354 (2015) 86.
- [13] K. Schießl, K. Tökési, B. Solleder, C. Lemell, J. Burgdörfer, *Phys. Rev. Lett.* 102 (2009) 163201.
- [14] D. Borka, K. Tökési, *Nucl. Instrum. Methods Phys. Res. B* 354 (2015) 112.
- [15] D. Borka, V. Borka Jovanović, C. Lemell, K. Tökési, *Nucl. Instrum. Methods Phys. Res. B* 406 (2017) 413.
- [16] Z.-J. Ding, R. Shimizu, *Surf. Sci.* 222 (1989) 313.
- [17] R. Shimizu, Y. Kataoka, T. Ikuta, T. Koshikawa, H. Hasimoto, *J. Phys. D: Appl. Phys.* 9 (1976) 101.
- [18] K. Tökési, D. Varga, L. Kövér, T. Mukoyama, *J. Electron Spectrosc. Relat. Phenom.* 76 (1995) 427.
- [19] K. Tökési, L. Wirtz, C. Lemell, J. Burgdörfer, *Phys. Rev. A* 64 (2001) 042902.
- [20] D.J. Manura, D.A. Dahl, SIMION Version 8.0, User Manual, Scientific Instruments Services Inc, 2007.
- [21] F. Salvat, R. Mayol, *Comput. Phys. Commun.* 74 (1993) 358.
- [22] D. Pines, *Elementary Excitations in Solids*, Benjamin, New York, 1964:127.
- [23] H. Ritchie, *Phys. Rev.* 106 (5) (1957) 874.
- [24] H. Ritchie, A.L. Marusak, *Surf. Sci.* 4 (1966) 234.
- [25] A.G. Eguluz, D.A. Campbell, *Phys. Rev. B* 31 (1985) 7572.
- [26] J.L. Gervasoni, F. Yubero, *Nucl. Instrum. Methods Phys. Res. B* 182 (2001) 96.
- [27] F. Salvat-Pujol, W.S.M. Werner, *Surf. Interface Anal.* 45 (2013) 873.
- [28] C.J. Powell, *Surf. Sci.* 44 (1974) 29.
- [29] D.R. Penn, *Phys. Rev. B* 35 (1987) 482.
- [30] J.J. Quinn, *Phys. Rev.* 126 (1962) 1453.
- [31] A.L. Fetter, J.D. Walecka, *Quantum Theory of Many-Particle Systems*, McGraw-Hill, New York, 1971:40.
- [32] J.C. Ashley, et al., *Surf. Sci.* 81 (1979) 409.
- [33] C.J. Tung, R.H. Ritchie, *Phys. Rev. B* 16 (1977) 4302.
- [34] H. Raether, *Excitation of Plasmons and Interband Transitions by Electrons*, Springer, Berlin, 1980, ch. 7.
- [35] K. Sturm, *Adv. Phys.* 31 (1982) 1.
- [36] J. Lindhard, K. Dan, *Vidensk. Selsk. Mat. Fys. Medd.* 28 (1954) 1.
- [37] W.S.M. Werner, K. Glantschnig, C. Ambrosch-Draxl, *J. Phys. Chem. Ref. Data* 38 (4) (2009) 1.
- [38] Private communications with W.S.M. Werner.



Dissociative electron attachment to coordination complexes of chromium: chromium(0) hexacarbonyl and benzene-chromium(0) tricarbonyl

Janina Kopyra^{*1}, Paulina Maciejewska¹ and Jelena Maljković²

Full Research Paper

Open Access

Address:

¹Faculty of Science, Siedlce University, 3 Maja 54, 08-110 Siedlce, Poland and ²Laboratory for Atomic Collision Processes, Institute of Physics Belgrade, University of Belgrade, Pregrevica 118, 11080 Belgrade, Serbia

Email:

Janina Kopyra^{*} - kopyra@uph.edu.pl

^{*} Corresponding author

Keywords:

benzene-chromium(0) tricarbonyl; chromium(0) hexacarbonyl; dissociative electron attachment; gas phase reactions; mass spectrometry

Beilstein J. Nanotechnol.

doi:

Received: 27 April 2017

Accepted: 28 September 2017

Published:

This article is part of the Thematic Series "Chemistry for electron-induced nanofabrication".

Guest Editor: P. Swiderek

© Kopyra et al.; licensee Beilstein-Institut.

License and terms: see end of document.

Abstract

Here we report the results of dissociative electron attachment (DEA) to gas-phase chromium(0) hexacarbonyl ($\text{Cr}(\text{CO})_6$) and benzene-chromium(0) tricarbonyl ($(\eta^6\text{-C}_6\text{H}_6)\text{Cr}(\text{CO})_3$) in the energy range of 0–12 eV. Measurements have been performed utilizing an electron-molecular crossed beam setup. It was found that DEA to $\text{Cr}(\text{CO})_6$ results (under the given experimental conditions) in the formation of three fragment anions, namely $[\text{Cr}(\text{CO})_5]^-$, $[\text{Cr}(\text{CO})_4]^-$, and $[\text{Cr}(\text{CO})_3]^-$. The predominant reaction channel is the formation of $[\text{Cr}(\text{CO})_5]^-$ due to the loss of one CO ligand from the transient negative ion. The $[\text{Cr}(\text{CO})_5]^-$ channel is visible via two overlapping resonant structures appearing in the energy range below 1.5 eV with a dominant structure peaking at around 0 eV. The peak maxima of the fragments generated by the loss of two or three CO ligands are blue-shifted and the most intense peaks within the ion yield curves appear at 1.4 eV and 4.7 eV, respectively. $(\eta^6\text{-C}_6\text{H}_6)\text{Cr}(\text{CO})_3$ shows a very rich fragmentation pattern with decomposition leading to the formation of seven fragment anions. Three of them are generated from the cleavage of one, two or three CO ligand(s). The energy of the peak maxima of the $[(\text{C}_6\text{H}_6)\text{Cr}(\text{CO})_2]^-$, $[(\text{C}_6\text{H}_6)\text{Cr}(\text{CO})]^-$, and $[(\text{C}_6\text{H}_6)\text{Cr}]^-$ fragments is shifted towards higher energy with respect to the position of the respective fragments generated from $\text{Cr}(\text{CO})_6$. This phenomenon is most likely caused by the fact that chromium–carbonyl bonds are stronger in the heteroleptic complex $(\eta^6\text{-C}_6\text{H}_6)\text{Cr}(\text{CO})_3$ than in homoleptic $\text{Cr}(\text{CO})_6$. Besides, we have observed the formation of anions due to the loss of C_6H_6 and one or more CO units. Finally, we found that Cr^- , when stripped of all ligands, is generated through a high-energy resonance, peaking at 8 eV.

Introduction

Organometallic compounds are a large class of compounds with numerous applications such as homogeneous catalysts for the synthesis of fine chemicals or even enantiomerically pure prod-

ucts used in the pharmaceutical industry [1-3]. However, they also play an important role in nanotechnology. In fact, a number of organometallic complexes, originally designed for chemi-

cal vapor deposition (CVD) purposes, have also been recognized as promising precursors for focused electron beam induced deposition (FEBID), a process to fabricate three-dimensional metal-containing nanoscale structures [4,5]. FEBID is a direct-write technique in which a highly focused, high-energy electron beam impinges on precursor molecules physisorbed onto a substrate, thereby causing their dissociation, and in the ideal case, leading to pure deposit formation. However, the primary electron (PE) beam striking the substrate gives rise to a large amount of back-scattered electrons (BSEs) and secondary electrons (SEs) [6-8]. It is nowadays very well known that these low energy electrons (<100 eV) may induce fragmentation of the adsorbed precursor molecules via various decomposition processes such as dissociative ionization (DI), dipolar dissociation (DD), neutral dissociation (ND), and dissociative electron attachment (DEA) [8]. These reactions occur with relatively high cross sections and typically result in partial fragmentation of the precursor molecules [9-11]. Therefore, SEs may play a role in determining the composition of the FEBID deposits. Moreover, they may also be responsible for the broadening of the deposits beyond the width of the PE beam since secondary electrons create an electron flux beyond the focal area diameter of the primary beam.

To date there have been several papers devoted to the studies of the interaction of low energy electrons with gas-phase organometallic complexes. Particular attention has been paid to the compounds containing monodentate (e.g., carbonyl [12-14], trifluorophosphine [11,15], chloride [16]), bidentate (e.g., hexafluoroacetylacetone [17]), and mixed ligands (e.g., nitrosyl and carbonyl [9,10], methyl and methylenecyclopentadienyl [18], π -allyl, carbonyl, bromide [19]). These studies cover both the fragmentation patterns and kinetics of electron attachment processes. It appears that for carbonyl compounds such as $\text{Ni}(\text{CO})_4$, $\text{Fe}(\text{CO})_5$, $\text{W}(\text{CO})_6$, $\text{Mo}(\text{CO})_6$, and $\text{Cr}(\text{CO})_6$ the rate constants at thermal energy are extremely high and range from $1-3 \times 10^{-7} \text{ cm}^3 \cdot \text{molecule}^{-1} \cdot \text{s}^{-1}$ [13]. These values approach the maximum (s-wave) thermal attachment rate constant of $5 \times 10^{-7} \text{ cm}^3 \cdot \text{molecule}^{-1} \cdot \text{s}^{-1}$ at a temperature of 298 K [20].

There is, however, still a need to find more efficient FEBIP precursors that will readily detach ligands upon interaction with electrons. According to the current understanding, precursors with large organic ligands are particularly unfavorable for FEBID because they lead to codeposition of large amounts of carbon [4,21]. However, as shown in this paper, for the case of a chromium complex carrying a benzene ligand, such large organic entities may be more easy to remove by electron irradiation than generally anticipated. Chromium complexes are of interest because they are used for various technological applications [22]. For instance, Cr is used in photomasks so that

Cr-containing FEBID precursors are of interest for mask repair [23] and $\text{Cr}(\text{CO})_6$ has in fact been studied as a FEBID precursor earlier [24]. In the present work, we report the results from DEA to the gas-phase chromium(0) hexacarbonyl ($\text{Cr}(\text{CO})_6$) and benzene-chromium(0) tricarbonyl ($(\eta^6\text{-C}_6\text{H}_6)\text{Cr}(\text{CO})_3$) [25] in the energy range of 0–12 eV. The first compound is homoleptic and hence contains one type of ligand, namely CO. The other compound is heteroleptic and contains both CO and a C_6H_6 ligand. CO is a monodentate ligand which means that only one atom within the ligand binds to the central metal atom. C_6H_6 is a η^6 (hexahapto) ligand which corresponds to a contiguous series of six atoms that coordinate to the metal center. The molecular structure of both complexes is depicted in Figure 1. $\text{Cr}(\text{CO})_6$ is a complex with 18 valence electrons (VEs) and adopts an octahedral molecular geometry, resulting in the O_h point group symmetry. Similarly, $(\eta^6\text{-C}_6\text{H}_6)\text{Cr}(\text{CO})_3$ has 18 VEs. However, it has a piano stool geometry with planar arrangement of the aryl group and three carbonyl groups which act as “legs”. Both complexes have spin-paired electrons and accordingly are diamagnetic. For such compounds, it has been postulated that DEA leads exclusively to the formation of fragment negative ions [26], without formation of parent anions, since the captured electron has to occupy an antibonding molecular orbital. In accordance with the predictions, we have observed the formation of three and seven fragment anions from $\text{Cr}(\text{CO})_6$ and $(\eta^6\text{-C}_6\text{H}_6)\text{Cr}(\text{CO})_3$, respectively, while the parent anion was not observed from any of the investigated complexes. In the following, the present results will be discussed in this context and in relation to the role of ligands in the respective DEA processes and compared with available literature data.

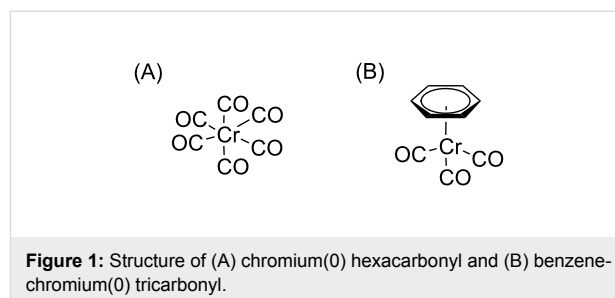

Experimental

Experiments were performed utilizing an electron-molecular crossed beam setup. As previously described in [27], it consists of a trochoidal electron monochromator (TEM), a quadrupole mass analyzer (QMA), and a secondary electron multiplier, which are housed in a high vacuum chamber. The electron beam (energy resolution in the range of 150–200 meV (FWHM), electron current $I \approx 10$ nA) generated with the TEM intersects with an effusive molecular beam, resulting in the formation of fragment anions. The molecular beam emanates from

a vessel which was introduced directly into the oven in the vacuum chamber. In order to obtain sufficiently high vapor pressure of the target molecules in the reaction area, the oven was heated by two halogen lamps to a temperature of 90–95 °C as measured by a Pt(100) resistance mounted at one of the flanges. The generated negative ions were extracted from the reaction area by a small electric field towards the QMA entrance and detected by a single pulse counting technique. The electron energy scale was calibrated by measuring the signal of SF_6^- , exhibiting an intense resonance near 0 eV. Base pressure was in the range of 3×10^{-8} mbar while the working pressure was in the range of either $4\text{--}5 \times 10^{-7}$ mbar or $2\text{--}4 \times 10^{-5}$ mbar for $\text{Cr}(\text{CO})_6$ and $(\eta^6\text{-C}_6\text{H}_6)\text{Cr}(\text{CO})_3$, respectively. In spite of almost the same operative temperature for both investigated compounds, the pressure of the homoleptic compounds was substantially lower in comparison with the heteroleptic compound. This implies a lower sublimation rate for the former compound. The $\text{Cr}(\text{CO})_6$ and $(\eta^6\text{-C}_6\text{H}_6)\text{Cr}(\text{CO})_3$ samples were purchased from Sigma-Aldrich with a stated purity of 98% and used as-delivered.

Results and Discussion

The impact of low-energy electrons on gas-phase chromium(0) hexacarbonyl ($\text{Cr}(\text{CO})_6$) and benzene-chromium(0) tricarbonyl ($(\eta^6\text{-C}_6\text{H}_6)\text{Cr}(\text{CO})_3$) has been investigated. Measurements have been taken as a function of incident electron energy in the energy range between 0–12 eV. In this energy range, it is very well known that DEA is responsible for the dissociation of the molecule. The DEA reaction is a two-step process in which, in a first step, an incident electron is captured by the target molecule to form a TNI. Since the TNI is not stable, it will decay in a second step either via autoionisation or via dissociation, forming a stable fragment anion and neutral counterpart(s). The formation of the fragment anion is only possible if the fragment at which the extra charge is localized possesses a positive value of the electron affinity. Depending on the energy at which DEA occurs, one can distinguish two types of resonances: one-particle resonance and two-particle one-hole resonance (core excited resonance) [28]. One-particle resonances take place within the subexcitation energy range <3–4 eV. They are due to a direct accommodation of the excess electrons into an unoccupied molecular orbital (MO). On the other hand, core excited resonances occur when the incoming electron transfers its energy to electronically excite the target molecule and hence becomes captured by the electron–molecule potential of the excited state.

Electron attachment to $\text{Cr}(\text{CO})_6$ leads, under the current experimental conditions, to the formation of three anionic fragments, $[\text{Cr}(\text{CO})_5]^-$, $[\text{Cr}(\text{CO})_4]^-$, and $[\text{Cr}(\text{CO})_3]^-$. The ion yield curves of these fragments are shown in Figure 2. The corresponding fragment anions are generated via:

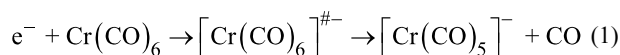

The predominant reaction channel is the formation of $[\text{Cr}(\text{CO})_5]^-$ through the cleavage of one CO ligand from the transient negative ion. This fragment shows a narrow and intense structure close to 0 eV within the ion yield curve and a less intense peak at 1 eV, which are attributed to one-particle resonances. The positions of the peaks correlate very well with the positions of the resonances reported from electron transmission spectroscopy (ETS) experiments [29]. Indeed, from ETS, the features emerge below 1 eV implying the occurrence of an attachment of electrons with energy close to 0 eV and near 1 eV. Based on the calculations, it has been suggested that the low energy maximum can be attributed to a negative ion state

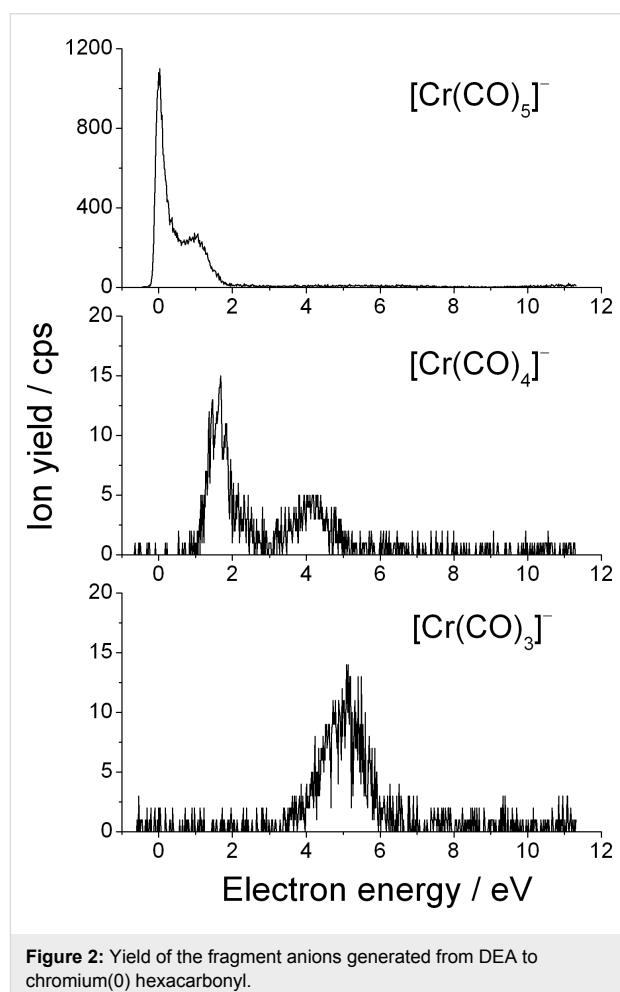

Figure 2: Yield of the fragment anions generated from DEA to chromium(0) hexacarbonyl.

emerging from electron capture into the $3t_{2g}$ orbital of this molecule [30]. A high cross section for the $[\text{Cr}(\text{CO})_5]^-$ ion formation already at energy close to 0 eV implies that the reaction is most likely exothermic, i.e., the electron affinity of the $\text{Cr}(\text{CO})_5$ fragment exceeds the bond energy of $\text{Cr}-\text{CO}$. According to the literature, the bond dissociation enthalpy of $\text{Cr}(\text{CO})_5-\text{CO}$ is equal to 1.6 eV [31], therefore the electron affinity of $\text{Cr}(\text{CO})_5$ should be ≥ 1.6 eV. A further reaction channel in DEA to $\text{Cr}(\text{CO})_6$ is the formation of $[\text{Cr}(\text{CO})_4]^-$, formed from the loss of two CO ligands. The ion yield curve is composed of two peaks, centered at 1.4 eV and 4.1 eV. The position of the first peak correlates well with the position of the resonance observed from ETS studies that has been assigned to capture into the $3t_{2u}$ orbital of this molecule [30]. Further abstraction of the CO ligand leads to the formation of $[\text{Cr}(\text{CO})_3]^-$ which extends from 3.3 to 6 eV and peaks at 5.0 eV. This structure can be attributed to a core excited resonance, however it should be stressed here that one-particle resonances may also be formed in this energy range and cannot be ruled out.

DEA studies on $\text{Cr}(\text{CO})_6$ have already been reported by Tossell et al. [30] as well as Winters and Kiser [32]. In the former paper, the negative ion current from $\text{Cr}(\text{CO})_6$ as a function of incident electron energy has been shown. The reported dominant feature was observed near 0.5 eV with shoulders between 1 and 2 eV and between 2 and 3 eV, which is in a fairly good agreement with our experimental results. The authors concluded that the vast majority of the ions observed were $[\text{Cr}(\text{CO})_5]^-$. The only exception was a peak near 1.6 eV where $[\text{Cr}(\text{CO})_4]^-$ contributed about 15% to the total ion current. In contrast, Winters and Kiser have observed formation of six fragment anions, i.e., $[\text{Cr}(\text{CO})_5]^-$, $[\text{Cr}(\text{CO})_4]^-$, $[\text{Cr}(\text{CO})_3]^-$, $[\text{Cr}(\text{CO})_2]^-$, $[\text{Cr}(\text{CO})]^-$, and $[\text{Cr}]^-$ [32]. In analogy to our results, the most intense fragment was generated from the cleavages of single CO ligands. The $[\text{Cr}(\text{CO})_4]^-$ and $[\text{Cr}(\text{CO})_3]^-$ anions were generated with an intensity of 30% of the main signal. Further signals were observed with relative intensity of 10%, 5%, and $<5\%$ for $[\text{Cr}(\text{CO})_2]^-$, $[\text{Cr}(\text{CO})]^-$, and $[\text{Cr}]^-$, respectively. Hence, the intensity of the missing fragments in our experiment is below the detection limit of our experimental setup. In particular, if we take into account that the intensity of the $[\text{Cr}]^-$ signal in Winters and Kiser's experiment is lower than 5% of $[\text{Cr}(\text{CO})_5]^-$ at 2.4 eV, we end up at the noise level. However, in their studies, Winters and Kiser could only observe a single peak for any of the reported fragment anions appearing above 2 eV. It should be stressed here that the maximum of the second peak for $[\text{Cr}(\text{CO})_4]^-$ and the maximum of the peak for $[\text{Cr}(\text{CO})_3]^-$ observed within the present studies match reasonably well to the position of the peaks reported by Winters and Kiser. There is, however, a big discrepancy between the positions of the dominant $[\text{Cr}(\text{CO})_5]^-$ fragment. While in our

studies the main peak appears already near 0 eV with a contribution at 1 eV, from the experiment of Winters and Kiser, it is reported to peak at 2.4 eV. It should be emphasized that the appearance of all observed anions, including the main peak of the $[\text{Cr}(\text{CO})_5]^-$ ion, above 2 eV in the latter studies contradicts also with the results of George and Beauchamp, who have shown that the rate constants at the thermal energy for dissociative electron capture by $\text{Cr}(\text{CO})_6$ approach the maximum thermal attachment rate constant equals to $3.2 \times 10^{-7} \text{ cm}^3 \cdot \text{molecule}^{-1} \cdot \text{s}^{-1}$ [13].

A particularly extensive fragmentation has been observed in DEA to the heteroleptic complex $(\eta^6\text{-C}_6\text{H}_6)\text{Cr}(\text{CO})_3$. In the case of electron attachment to $(\eta^6\text{-C}_6\text{H}_6)\text{Cr}(\text{CO})_3$, we observe the production of seven fragment anions: $[(\text{C}_6\text{H}_6)\text{Cr}(\text{CO})_2]^-$, $[(\text{C}_6\text{H}_6)\text{Cr}(\text{CO})]^-$, $[(\text{C}_6\text{H}_6)\text{Cr}]^-$, $[\text{Cr}(\text{CO})_3]^-$, $[\text{Cr}(\text{CO})_2]^-$, $[\text{CrCO}]^-$, and Cr^- in the electron energy range of 0–12 eV. These fragments can be divided into two groups: a first group which contains the anions generated by the loss of one or more CO ligands and the second one which includes the anions formed from the loss of the C_6H_6 unit or the loss of C_6H_6 and one or more CO units. The fragment anions which form the first group are generated via:

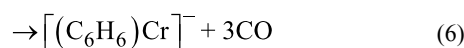
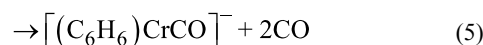
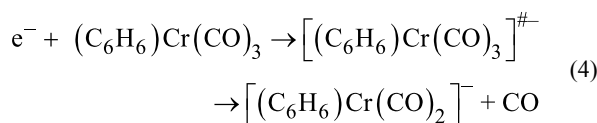

The ion yield curves of these fragments are shown in Figure 3. At first glance it becomes obvious that the predominant fragment is due to the loss of one CO ligand. This is consistent with our results obtained for the homoleptic chromium complex $\text{Cr}(\text{CO})_6$ as well as the previously studied ruthenium complex containing multicoordinated π -allyl ligands $(\eta^3\text{-C}_3\text{H}_5)\text{Ru}(\text{CO})_3\text{Br}$ [19]. The $[(\text{C}_6\text{H}_6)\text{Cr}(\text{CO})_2]^-$ anion is visible via two strongly overlapping structures at 0.85 eV and 1.7 eV. Hence, it is shifted towards higher energy with respect to the position of the fragment anion formed from the loss of a single CO ligand from $\text{Cr}(\text{CO})_6$. This shift can be caused mainly by the fact that chromium–carbonyl bonds are stronger in the heteroleptic complex $(\eta^6\text{-C}_6\text{H}_6)\text{Cr}(\text{CO})_3$ than in homoleptic $\text{Cr}(\text{CO})_6$ (see [31] and references therein). The $[(\text{C}_6\text{H}_6)\text{CrCO}]^-$ channel associated with the loss of two CO groups has a threshold at 2.5 eV and two resonances are present

within the yield curve peaking at 3.5 eV and 8.3 eV. The abstraction of a further CO unit results in the formation of $[(C_6H_6)Cr]^-$. The threshold for this reaction channel is somewhat shifted towards higher energy, that is to 3.3 eV, in comparison to the fragment formed from the loss of two CO units. Within the ion yield curve one can distinguish three resonances centered at 4.1, 6.0 and 8.2 eV. From Figure 3 it can be clearly seen that the efficiency of the reaction channel decreases with the number of carbonyl groups that are detached from the TNI to form the respective anions. This behavior has already been reported from DEA to metal carbonyls (e.g., $Ni(CO)_4$, $Fe(CO)_5$, $Cr(CO)_6$, $Mo(CO)_6$, $W(CO)_6$) [32], as well as from cobalt tricarbonylnitrosyl [9], and π -allyl ruthenium tricarbonyl bromide [19].

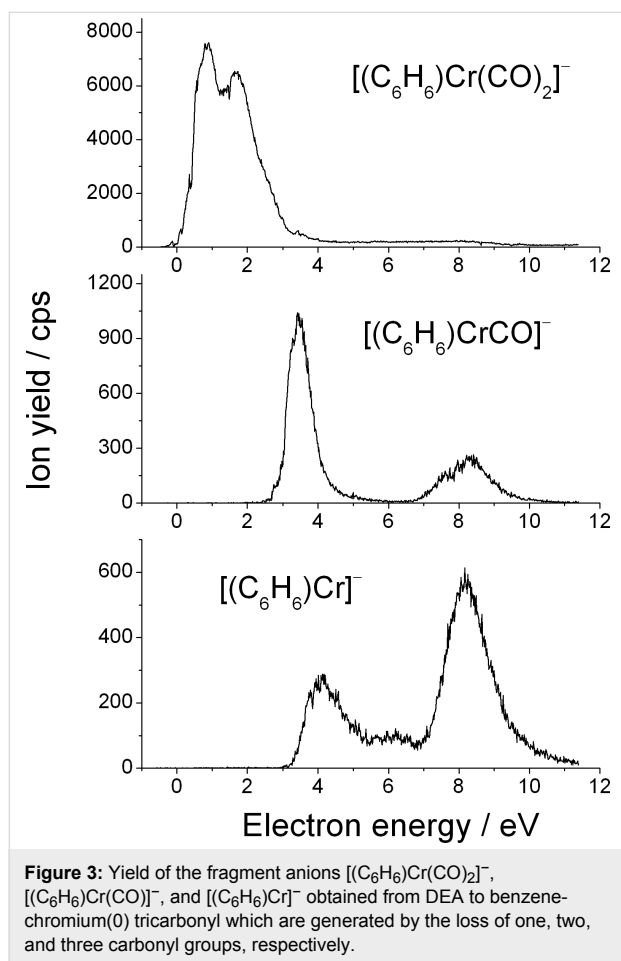

The second group of anionic products is formed by the following four dissociative channels:

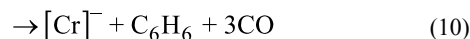
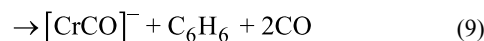
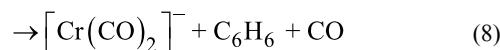
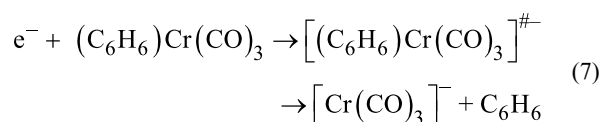

As mentioned above, this group consists of fragment anions generated from the loss of the C_6H_6 ligand or the loss of C_6H_6 and one or more CO ligands to form $[Cr(CO)_3]^-$, $[Cr(CO)_2]^-$, $[CrCO]^-$, and Cr^- , respectively (Figure 4). The predominant

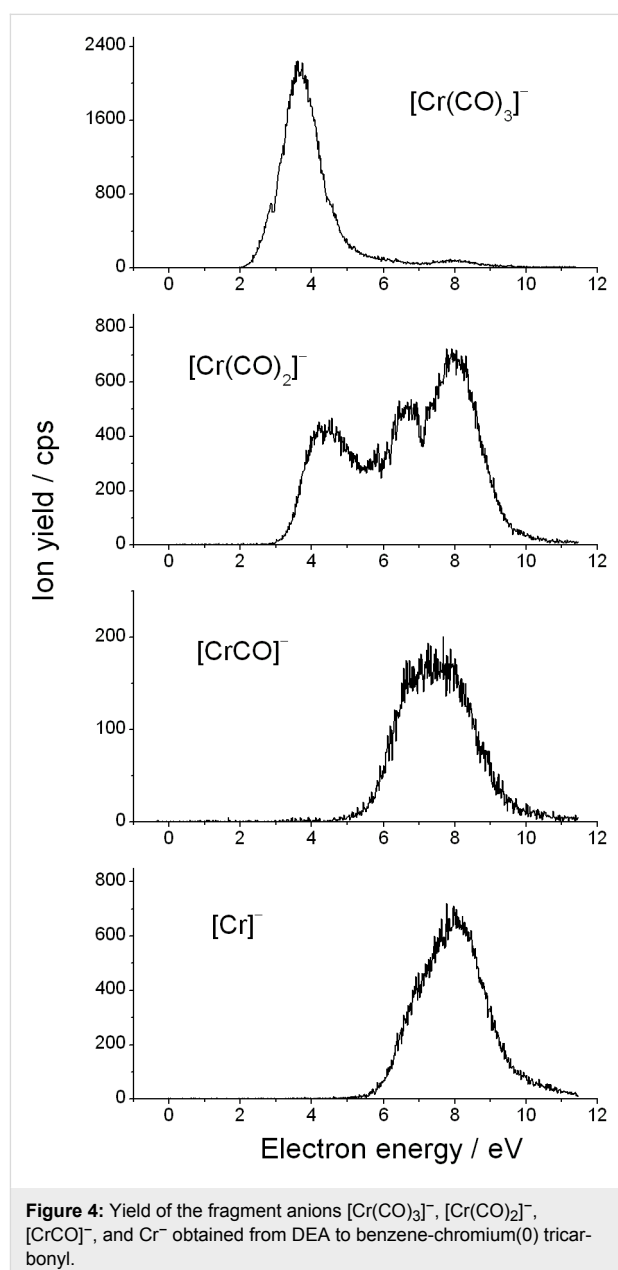

fragment from the second group is formed as a result of the loss of the C₆H₆ unit. The main contribution to the ion yield of [Cr(CO)₃]⁻ is visible through a resonance structure peaking at 3.7 eV with a low intensity structure at around 7.9 eV. Considering all the fragments generated from DEA to (C₆H₆)Cr(CO)₃, this is the second most intense signal. Such a high intensity of [Cr(CO)₃]⁻ has to be related to the lability of the C₆H₆ group. This is a striking finding since, in general, the multicentered π-bonded ligands are recognized to be particularly persistent in FEBID, and hence should be avoided [18,19]. However, it should be emphasized here that the C₆H₆ group is neutral in contrast to, for example, the methylcyclopentadienyl ligand, which may facilitate the detachment of the C₆H₆ group from the (C₆H₆)Cr(CO)₃ complex.

The [Cr(CO)₂]⁻ anion extends in a very broad energy range from 3.3 eV to 10 eV and is visible via three strongly overlapping resonant structures peaking at 4.5, 6.5 and 7.9 eV. Further loss of CO results in the formation of [CrCO]⁻ which appears in the high energy domain with a peak maximum at 7.5 eV. Since the peak is very broad, the threshold for the reaction channel is as low as 5.5 eV. Finally, we would like to point out that we observe the formation of a bare chromium anion, Cr⁻. The yield curve of Cr⁻ stretches from 6 to 11 eV and peaks around 8 eV and has a pronounced shoulder at the low energy side. It is worth mentioning that Cr⁻ is generated with an exceptionally high relative cross section, which is untypical when considering organometallic complexes including those with multicoordinated ligands. Indeed, as obvious from the reports on (η³-C₃H₅)Ru(CO)₃Br [19], MeCpPtMe₃ [18], Co(CO)₃NO [9], and HFeCo₃(CO)₁₂ [33], the bare metal ions were either not observed or observed with very low intensity (below 0.5% of the most intense anionic fragment).

Conclusion

In the present contribution, we have investigated how different ligands within coordination complexes modify the formation of transient negative ion (TNIs) and their subsequent decay by dissociation. In particular, by selecting homo- and heteroleptic complexes, namely Cr(CO)₆ and (η⁶-C₆H₆)Cr(CO)₃, we have studied the influence of the substitution of three CO units by the hexahapto C₆H₆ unit on electron-induced fragmentation. In general, we have observed the electron-driven decomposition of chromium(0) hexacarbonyl and benzene-chromium(0) tricarbonyl complexes into three ([Cr(CO)₅]⁻, [Cr(CO)₄]⁻, and [Cr(CO)₃]⁻) and seven ([C₆H₆)Cr(CO)₂]⁻, [(C₆H₆)Cr(CO)]⁻, [(C₆H₆)Cr]⁻, [Cr(CO)₃]⁻, [Cr(CO)₂]⁻, [CrCO]⁻, and Cr⁻) fragment anions, respectively. The energy of the peak maxima and intensity of the [M-(CO)_x]⁻ fragment anions (where M = neutral molecule, and x can be equal to 1, 2 or 3) generated from both investigated complexes varied in an anticipated

fashion. Such a stepwise increase in the energy and decrease in the intensity as more CO ligands are removed has been previously reported for a series of transition-metal carbonyls [14,32]. It has also been suggested that such a behavior may be reminiscent of a successive removal of CO fragments in the cracking patterns of the negative ions. Hence, it is very likely that the [M(CO)_x]⁻ anions, besides the direct decomposition of TNI, may also be generated via sequential, metastable decay.

In the framework of the potential role of coordination complexes of chromium for FEBID applications, we note that the removal of C₆H₆ and all CO ligands to form exceptionally intense signal of bare [Cr]⁻ has been observed in DEA to (η⁶-C₆H₆)Cr(CO)₃. On the basis of our results it seems to be plausible to consider a multicentered benzyl group as a promising leaving group within FEBID precursors.

Acknowledgments

This work has been supported by a statutory activity subsidy (No. 277/S/11) from the Polish Ministry of Science and Higher Education. J. M. acknowledges support for a visit to Siedlce University, Siedlce (Poland) from the European Union via the COST Action CM1301 (CELINA). Part of this work has already been presented during the 28th Summer School and International Symposium on the Physics of Ionized Gases, held on Aug. 29–Sept. 2, 2016 in Belgrade [25].

References

- Crabtree, R. H. *The Organometallic Chemistry of the Transition Metals*, 6th ed.; John Wiley & Sons: Hoboken, New Jersey, 2014. doi:10.1002/9781118788301
- Mudi, S. Y.; Usman, M. T.; Ibrahim, S. *Am. J. Chem. Appl.* **2015**, *2*, 151–158.
- Abd-El-Aziz, A. S.; Carraher, C. E., Jr.; Pittman, C. U., Jr.; Sheats, J. E.; Zeldin, M., Eds. *Macromolecules Containing Metal and Metal-Like Elements, Biomedical Applications*; John Wiley & Sons: Hoboken, New Jersey, 2004; Vol. 3. doi:10.1002/0471683779
- Utke, I.; Hoffmann, P.; Melngailis, J. *J. Vac. Sci. Technol., B* **2008**, *26*, 1197–1276. doi:10.1116/1.2955728
- van Dorp, W. F.; Hagen, C. W. *J. Appl. Phys.* **2008**, *104*, 081301. doi:10.1063/1.2977587
- Silvis-Cividjian, N.; Hagen, C. W.; Leunissen, L. H. A.; Kruit, P. *Microelectron. Eng.* **2002**, *61–62*, 693–699. doi:10.1016/S0167-9317(02)00515-4
- Botman, A.; de Winter, D. A. M.; Mulders, J. J. L. *J. Vac. Sci. Technol., B* **2008**, *26*, 2460–2463. doi:10.1116/1.2976576
- Thorman, R. M.; Kumar, R. T. P.; Fairbrother, D. H.; Ingólfsson, O. *Beilstein J. Nanotechnol.* **2015**, *6*, 1904–1926. doi:10.3762/bjnano.6.194
- Engmann, S.; Stano, M.; Matejčík, Š.; Ingólfsson, O. *Angew. Chem., Int. Ed.* **2011**, *50*, 9475–9477. doi:10.1002/anie.201103234
- Engmann, S.; Stano, M.; Papp, P.; Brunger, M. J.; Matejčík, S.; Ingólfsson, O. *J. Chem. Phys.* **2013**, *138*, 044305. doi:10.1063/1.4776756

11. May, O.; Kubala, D.; Allan, M. *Phys. Chem. Chem. Phys.* **2012**, *14*, 2979–2982. doi:10.1039/C2CP23268E
12. Wnorowski, K.; Stano, M.; Matias, C.; Denifl, S.; Barszczewska, W.; Matejčík, Š. *Rapid Commun. Mass Spectrom.* **2012**, *26*, 2093–2098. doi:10.1002/rcm.6324
13. George, P. M.; Beauchamp, J. L. *J. Chem. Phys.* **1982**, *76*, 2959–2964. doi:10.1063/1.443389
14. Compton, R. N.; Stockdale, J. A. D. *Int. J. Mass Spectrom. Ion Phys.* **1976**, *22*, 47–55. doi:10.1016/0020-7381(76)80106-4
15. Allan, M. *J. Chem. Phys.* **2011**, *134*, 204309. doi:10.1063/1.3594206
16. Neustetter, M.; Ferreira da Silva, F.; Denifl, S. *Rapid Commun. Mass Spectrom.* **2016**, *30*, 1139–1144. doi:10.1002/rcm.7542
17. Engmann, S.; Ómarsson, B.; Lacko, M.; Stano, M.; Matejčík, S.; Ingólfsson, O. *J. Chem. Phys.* **2013**, *138*, 234309. doi:10.1063/1.4810877
18. Engmann, S.; Stano, M.; Matejčík, Š.; Ingólfsson, O. *Phys. Chem. Chem. Phys.* **2012**, *14*, 14611–14618. doi:10.1039/c2cp42637d
19. Thorman, R. M.; Brannaka, J. A.; McElwee-White, L.; Ingólfsson, O. *Phys. Chem. Chem. Phys.* **2017**, *19*, 13264–13271. doi:10.1039/C7CP01696D
20. Christophorou, L. G. *Electron–Molecule Interactions and Their Applications*; Academic Press: Orlando, 1984; Vol. 2.
21. Botman, A.; Mulders, J. J. L.; Hagen, C. W. *Nanotechnology* **2009**, *20*, 372001. doi:10.1088/0957-4484/20/37/372001
22. Zhong, Z.; Cheng, R. *Mater. Res. Soc. Symp. Proc.* **2001**, *635*, C4.25. doi:10.1557/PROC-635-C4.25
23. Bret, T.; Hofmann, T.; Edinger, K. *Appl. Phys. A* **2014**, *117*, 1607–1614. doi:10.1007/s00339-014-8601-2
24. Kislov, N. A.; Khodos, I. I.; Ivanov, E. D.; Barthel, J. *Scanning* **1996**, *18*, 114–118. doi:10.1002/sca.1996.4950180205
25. Maljkovic, J.; Maciejewska, P.; Kopyra, J. Dissociative electron attachment to benzene chromium tricarbonyl. In *Proceedings of the 28th Summer School and International Symposium on the Physics of Ionized Gases*, Belgrade, Serbia, Aug 29–Sept 2, 2016; Marić, D.; Milosavljević, A.; Obradović, B.; Poparić, G., Eds.; University of Belgrade, Faculty of Physics: Belgrade, Serbia, 2016; pp 39–42. <http://www.spig2016.ipb.ac.rs/spig2016-book-online.pdf>
26. Sullivan, R. E.; Lupin, M. S.; Kiser, R. W. *J. Chem. Soc. D* **1969**, 655a. doi:10.1039/c2969000655a
27. Koenig-Lehmann, C.; Kopyra, J.; Dabkowska, I.; Kočišek, J.; Illenberger, E. *Phys. Chem. Chem. Phys.* **2008**, *10*, 6954–6961. doi:10.1039/b812130c
28. Illenberger, E.; Momigny, J. *Gaseous Molecular Ions: An Introduction to Elementary Processes Induced by Ionization*; Steinkopff Verlag: Darmstadt, Germany, 1992. doi:10.1007/978-3-662-07383-4
29. Giordan, J. C.; Moore, J. H.; Tossell, J. A. *J. Am. Chem. Soc.* **1981**, *103*, 6632–6636. doi:10.1021/ja00412a018
30. Tossell, J. A.; Moore, J. H.; Olthoff, J. K. *J. Am. Chem. Soc.* **1984**, *106*, 823–824. doi:10.1021/ja00315a078
31. Simoes, J. A. M.; Beauchamp, J. L. *Chem. Rev.* **1990**, *90*, 629–688. doi:10.1021/cr00102a004
32. Winters, R. E.; Kiser, R. W. *J. Chem. Phys.* **1966**, *44*, 1964–1966. doi:10.1063/1.1726969
33. Kumar, R. T. P.; Björnsson, R.; Barth, S.; Ingólfsson, O. *Chem. Sci.* **2017**, *8*, 5949–5952. doi:10.1039/c7sc01927k

License and Terms

This is an Open Access article under the terms of the Creative Commons Attribution License (<http://creativecommons.org/licenses/by/4.0>), which permits unrestricted use, distribution, and reproduction in any medium, provided the original work is properly cited.

The license is subject to the *Beilstein Journal of Nanotechnology* terms and conditions: (<http://www.beilstein-journals.org/bjnano>)

The definitive version of this article is the electronic one which can be found at:
doi:

Elastic electron scattering cross sections for triethyl phosphate molecule at intermediate electron energies from 50 eV to 250 eV^{*,**}

Jelena B. Maljković¹, Jelena Vuković², Károly Tökési^{3,4},
Branko Predojević², and Bratislav P. Marinković^{1,a}

¹ Institute of Physics Belgrade, University of Belgrade, Pregrevica 118, 11080 Belgrade, Serbia

² Faculty of Science, University of Banja Luka, Mladena Stojanovića 2, 78000 Banja Luka, Republic of Srpska, Bosnia and Herzegovina

³ Institute for Nuclear Research, Hungarian Academy of Sciences (ATOMKI), Debrecen, Hungary

⁴ ELI-ALPS, ELI-HU Non-Profit Kft., Szeged, Hungary

Received 15 November 2018

Published online (Inserted Later)

© EDP Sciences / Società Italiana di Fisica / Springer-Verlag GmbH Germany, part of Springer Nature, 2019

Abstract. We present a combined experimental and theoretical study of the electron elastic differential cross sections of triethyl phosphate molecule ($(C_2H_5)_3PO_4$ (TEP)). The experimental setup based on a crossed beam technique comprising of an electron gun, a single capillary gas needle and a detection system with a channeltron was used to measure differential cross sections. The absolute scale for the cross sections is obtained by relative-flow method using argon gas as a reference. For the interpretation of the measured data we applied the partial expansion method to calculate the elastic cross sections of TEP. We found excellent agreement between the shapes of measured and calculated data.

1 Introduction

Electron interaction research with biological material, as well as subsequent damage caused by in the media, has attracted a considerable scientific interest in recent years, especially in molecular physics and biomedicine. The reason for this is the fact that electrons play a key role in numerous biomedical applications, for both diagnostic and therapeutic purposes. Today it is well accepted that secondary electrons (SE) are extensively generated by passing primary beam through the medium ($\sim 4 \times 10^4$ per MeV energy transferred to the medium) and are considered the main cause of radiation damage in biological tissues [1].

Due to a large number of involved processes, the mechanism of damaging of a complex DNA by the radiation molecule is very difficult to clarify. Studies with isolated DNA elements (e.g. nucleobases [2]) or with molecules

analogous to DNA (e.g. molecules analogous to deoxyribose [3–6] or molecule analogous to pyrimidine bases [7]) provide a good insight into the molecular mechanisms that lead to the DNA damage, which connects the macroscopic effects of radiation with molecular-level damage.

The motivation to study electron interaction with triethyl phosphate (TEP, $C_6H_{15}O_4P$) comes from radiation damage research, since this molecule may be considered as an analogue to phosphate group, which together with the sugar deoxyribose, forms the backbone of the DNA molecule (see Fig. 1). Our results should bring information about electron–triethyl phosphate interactions and we will discuss their relevance to electron-induced damage to the DNA backbone. This investigation also would be an extension to our previous measurements with molecules that are analogue to some parts of DNA molecule [3–7]. To our knowledge, there are no published absolute differential cross sections for electron interaction by triethyl phosphate in this intermediate electron energy range.

Dissociative electron attachment spectrum for TEP and for low energy incident electrons has been reported [8]. In that research authors used triethyl phosphate molecule to simulate the behavior of the phosphate group in DNA towards the attack of low energy electrons. They found that the compound undergoes effective dissociative electron attachment within a low energy resonant feature at 1 eV and a further resonance peaking at 8 eV [8]. Also

* Contribution to the Topical Issue “Many Particle Spectroscopy of Atoms, Molecules, Clusters and Surfaces”, edited by Károly Tökési, Béla Paripás, Gábor Pszota, and Andrey V. Solov'yov.

** Supplementary material in the form of one pdf file available from the Journal web page at <https://doi.org/10.1140/epjd/e2019-90631-1>

^a e-mail: bratislav.marinkovic@ipb.ac.rs

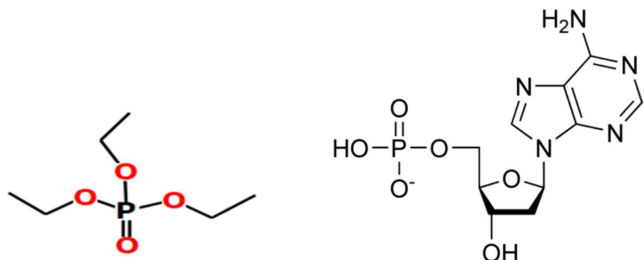

Fig. 1. Triethyl phosphate (TEP) and DNA backbone.

investigating DEA processes on TEP [9] it has been found the loss of an ethoxy radical due to P–O bond cleavage. It was emphasized that for the phosphate group in DNA both reactions would correspond to a direct single strand break [9].

In this paper, absolute differential cross sections (DCSs) for elastic electron-TEP scattering at incident electron energies from 50 eV to 250 eV are presented. Results are obtained using crossed electron-target beam apparatus. Absolute values, which are used to normalize relative DCSs, are determined by the relative flow method.

2 Experiment

The experimental results are obtained on the crossed electron-atom (molecule) beam apparatus. Incident electrons are derived from an electron gun that consists of seven electrodes; four for the extraction of electrons emitted by thermoelectronic emission from the cathode and three for the focusing of the beam to the interaction volume. The electron energy is determined by the potential difference between the cathode and the last electrode which is grounded and can be varied in the range from 40 eV to 300 eV. Energy resolution of the electron spectrometer is defined by the thermal distribution of the primary electrons and is approximately 0.5 eV.

The electrons interact with a molecular beam formed by a stainless-steel gas needle and further slowed down and focused by the four-element electron lens into the double cylindrical mirror analyzer which selects them by the energy. After passing through the analyzer, the electrons are focused by three-element electron lens to the detector, single channel electron multiplier. All mentioned experimental elements are located inside a vacuum chamber. Base pressure of about 6×10^{-7} mbar, is achieved using a turbo molecular pump. The operating pressure was about one order higher. The electron gun can be rotated around the gas needle from -40° to 130° , while the angular resolution of the analyzer was approximately $\pm 2^\circ$.

The relative DCSs for elastic electron scattering are measured as a function of scattering angle, from 25° to 125° (in 5° steps), at a given electron impact energy from 50 eV to 250 eV (in 50 eV steps). The intensity of elastically scattered electrons is measured at the maximum of elastic peak in energy loss spectrum and is directly proportional to the relative DCSs at a selected electron energy. In this experiment, voltages on electron gun and double cylindrical mirror analyzer are adjusted so that the

scattering volume is within the view cone of the analyzer, achieving the interaction volume constant. The deviations can occur at small scattering angles (below 35°). Corrections at the small angles and lower energies are made by comparing the cross sections for noble gases, in this case argon, with previous published results from other authors. The contribution of background is measured by introducing target gas into the chamber through the side leak (it has been around 10–15% of the true signal) and is subtracted from the apparent signal for each measured point. These two measurements were performed at least three times for each electron energy of interest. Subtracting the background from signal yields three corrected measurements which were weighted and averaged. For each electron energy, the analyser was set to allow the electrons corresponding to the elastic peak to pass through. Accordingly, the electron gun and two lenses before and after the analyser were readjusted for optimal signal and to compensate for the transmission functions.

The relative differential cross-sections are further normalized to the absolute scale using absolute points (at the angles 40° , 80° , 90° or 100°), by the relative flow method. Argon was used as the referent gas, with known cross sections published by Ranković et al. [10] for the incident electron energies from 50 eV to 200 eV, and Williams and Willis [11] for electron energy 250 eV. In this method, the signal of the elastic scattered electrons for the target molecule is compared with the signal for the referent gas, at the same angle of scattering, for the same energy of the incident electrons, under the same experimental conditions (the same profiles of the beams, the same mean free paths [12], the pressure ratio behind the gas needle of the tested molecule and the reference gas must be inversely proportional to the ratio of the squares gas kinetic diameters. Since it is known that the gas kinetic diameter of argon is 3.58 Å, and for triethyl phosphate it is taken to be approximately 8 Å, then the necessary pressure ratio is set at about 5. The relative flow rate has been determined by closing an outlet to the chamber, admitting target gases into a closed constant volume and then measuring the pressure increase in time (measured by a MKS baratron). The flow is determined from the experimental curve of pressure versus time fitted by the least-squares method. The background contribution for each measured point, which contains both argon and triethyl phosphate, is subtracted from the signal. The influence of adsorption effects on gas line surfaces to the relative flow measurements [13] is reduced in the present case by heating the whole system.

TEP was purchased from Aldrich with a declared purity better than 99%. Before starting the measurements a few freeze-thaw-pump cycles under vacuum have been made. TEP is a liquid at room temperature and was introduced into the scattering region from a glass container via gas line system. This molecule is characterized by low vapor pressure (0.39 mmHg at 25°C) and very high dipole moment (2.86 D). Therefore, for stable experimental conditions during gas phase measurements, target container was heated around 80°C , like for previously studied “sticky” molecular targets such as THF and its

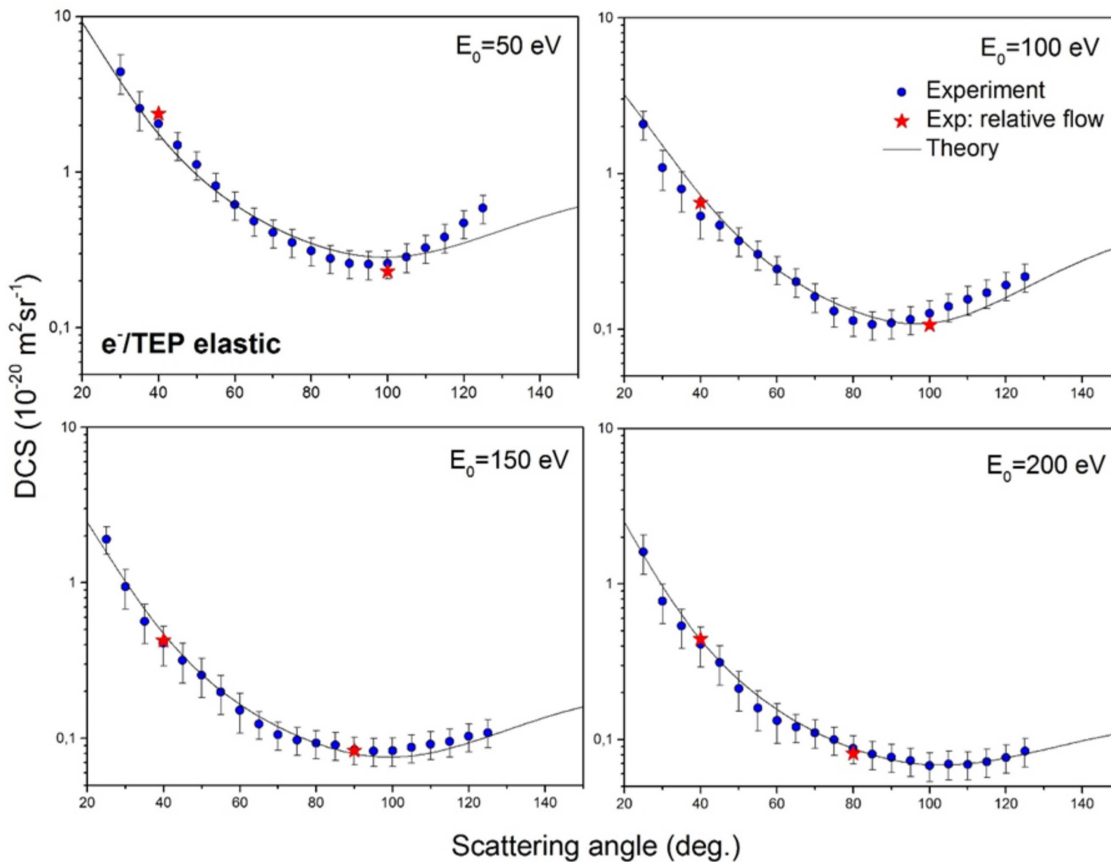

Fig. 2. Angular dependence of the DCSs for elastic electron scattering from TEP at different, fixed incident energies. Circles represent absolute experimental differential cross sections; stars represent absolute values obtained by relative flow method, where reference points for Ar are taken from paper by Ranković et al. [10]; full line represents theoretical results. Theory is normalized to the experimental results.

153 derivatives [14]. In the present work, pipes and the needle
 154 were also heated providing a stable driving pressure
 155 behind the needle and also for avoiding the absorption
 156 effects.

157 The errors of the relative cross section include statisti-
 158 cal errors (0.2–4%) and errors due to the instability of the
 159 system, short term stability errors, which are determined
 160 by the spread in the repeated measurements at the same
 161 electron energies and the same scattering angle (1.5–6%).
 162 The total error of relative measurements was increased by
 163 20% at small scattering angles due to the possible change
 164 in the interaction volume. The errors for absolute differ-
 165 ential cross sections are dominated by the errors of the
 166 reference DCSs for Ar. Errors for the flow rate are ignored
 167 due to stable experimental conditions and linear pressure
 168 increase with time. The errors for the reference absolute
 169 DCSs are about 20%. The total errors for absolute DCSs
 170 are about 25%.

171 3 Theory

172 In this work, the key of the determination of the elastic
 173 cross section calculations of TEP is the atomic cross sec-
 174 tion calculations for the components of the molecule. The
 175 calculated atomic cross sections were simple added accord-
 176 ing to the stoichiometry numbers to estimate the elastic

177 cross section of TEP. We note that in this way maybe the
 178 absolute cross sections of the molecule are overestimated
 179 because the shielding of the cross sections for various com-
 180 ponent of the molecule is not taken into account. However,
 181 we believe that the shape of the angular differential cross
 182 can be calculated accurately.

183 For the atomic target the partial expansion method was
 184 used to describe the differential cross sections for elastic
 185 scattering. The relativistic differential cross section per
 186 unit solid angle is given by the following form:

$$\frac{d\sigma_e}{d\Omega} = |f(\theta)|^2 + |g(\theta)|^2, \quad (1)$$

187 where θ is scattering angle, $f(\theta)$ and $g(\theta)$ are the spin-up
 188 and spin-down scattering amplitudes. $f(\theta)$ and $g(\theta)$ can
 189 be expressed as:

$$f(\theta) = \sum_{l=0}^{\infty} F_l P_l(\cos(\theta)), \quad (2)$$

$$g(\theta) = \sum_{l=0}^{\infty} G_l P_l^1(\cos(\theta)), \quad (3)$$

177
 178
 179
 180
 181
 182
 183
 184
 185
 186
 187
 188
 189

190

191 where $P_l(\cos(\theta))$ are the Legendre polynomials,
 192 $P_l^1(\cos(\theta))$ are the associated Legendre functions. F_l and
 193 G_l can be calculated according to following relations:

$$194 \quad F_l = \frac{1}{2ik} \{ (l+1) [\exp(2i\delta_{l+}) - 1] + l [\exp(-2i\delta_{l-}) - 1] \} \quad (4)$$

$$195 \quad G_l = \frac{1}{2ik} [\exp(2i\delta_{l-}) - \exp(-2i\delta_{l+})] \quad (5)$$

196 where δ_{l+} , δ_{l-} are the phase shift of the order l , and k is
 197 the momentum of the projectile electron. Details of the
 calculations can be found in reference [15].

198 4 Results

199 Absolute differential cross sections for elastic electron
 200 scattering from TEP molecule are presented in Figure 2.
 201 (circles-measured points; full line-calculated values) for
 202 the incident electron energies from 50 eV to 250 eV. Absolute
 203 DCSs for Ar in the energy range from 50 eV to 200 eV
 204 are taken from Ranković et al. [10]. In Figure 3. absolute
 205 differential cross sections for the incident electron energy
 206 of 250 eV are presented, where referent absolute cross
 207 sections for Ar are taken from the paper Williams and Willis
 208 [11]. Absolute points obtained by the relative flow method,
 209 on certain incident electron energies and scattering angles,
 210 used for normalization of relative measurements on absolute
 211 scale, are presented as well (stars). It can be noted
 212 that the absolute points agree well with the independently
 213 measured relative differential cross sections, which can
 214 be used as confirmation of the reliability of experimental
 215 methods, because it comprises of two independent set
 216 of data. The measured absolute results are also shown in
 217 Table 1. Theoretical results are normalized on the exper-
 218 imental data at an angle of 60° , for the incident electron
 219 energies 50 eV, 100 eV and 250 eV, and 80° for energies
 220 150 and 200 eV. The agreement between the measured
 221 points and the theory is within the experimental error
 222 in the whole angular range, except for energy 50 eV at
 223 larger scattering angles, where the experimental results
 224 are slightly higher on the absolute scale. DCSs show a
 225 wide minimum at the scattering angle about 90° , for the
 226 energies 50 eV and 100 eV, which slowly disappears for
 227 energies above 150 eV. This tendency is also observed in
 228 DCSs for elastic electron scattering on other previously
 229 measured molecules [3–7]. This indicates a similar redistri-
 230 bution of elastically scattered electrons on molecules
 231 analogous to the DNA building blocks in the medium
 232 energy range. In the investigated energy range, from 50 eV
 233 to 250 eV. Absolute differential cross-sections are reduced
 234 by about an order of magnitude, in the energy range from
 235 50 eV to 250 eV. That behavior we have also noticed for
 236 previous targets [3–7].

237 5 Conclusion

238 Elastic scattering of electrons from triethyl phosphate
 239 molecule is investigated experimentally and theoretically

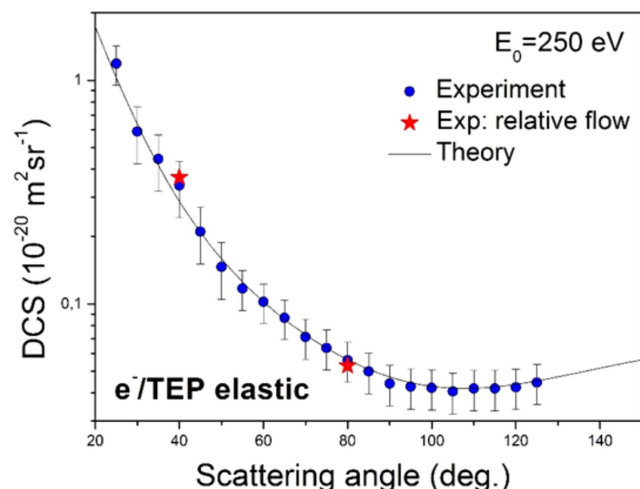

Fig. 3. The same as in Figure 2 but for 250 eV incident electron energy. The reference points for Ar are taken from paper Williams and Willis [11].

Table 1. Experimentally obtained DCSs for elastic electron scattering from TEP as a function of scattering angle at fixed electron energies. Total absolute errors rounded to the last two significant digits are given in brackets.

θ ($^\circ$)	DCS ($10^{-20} \text{ m}^2 \text{ sr}^{-1}$)				
	50 (eV)	100 (eV)	150 (eV)	200 (eV)	250 (eV)
25	—	2.08(43)	1.90(39)	1.61(46)	1.19(24)
30	4.4(1.2)	1.09(31)	0.95(27)	0.78(21)	0.59(17)
35	2.57(74)	0.79(23)	0.57(16)	0.54(15)	0.44(13)
40	2.05(42)	0.53(15)	0.41(12)	0.41(12)	0.993(96)
45	1.49(31)	0.466(97)	0.318(91)	0.312(89)	0.211(60)
50	1.12(23)	0.369(77)	0.255(73)	0.213(61)	0.147(42)
55	0.82(17)	0.302(63)	0.198(56)	0.159(46)	0.117(23)
60	0.62(13)	0.243(51)	0.151(43)	0.132(38)	0.102(21)
65	0.49(10)	0.201(42)	0.123(25)	0.120(25)	0.087(18)
70	0.409(84)	0.162(34)	0.106(22)	0.111(23)	0.071(14)
75	0.354(73)	0.313(27)	0.097(20)	0.099(21)	0.064(13)
80	0.312(64)	0.113(24)	0.093(19)	0.088(18)	0.056(11)
85	0.279(58)	0.107(22)	0.091(18)	0.081(17)	0.050(10)
90	0.259(54)	0.109(23)	0.085(17)	0.077(16)	0.0441(90)
95	0.256(53)	0.115(24)	0.083(17)	0.073(15)	0.0427(88)
100	0.260(54)	0.126(26)	0.083(17)	0.068(14)	0.0423(86)
105	0.285(59)	0.139(29)	0.088(18)	0.070(14)	0.0407(84)
110	0.326(67)	0.155(32)	0.092(19)	0.069(14)	0.0420(86)
115	0.382(79)	0.171(36)	0.095(19)	0.072(15)	0.0419(86)
120	0.471(97)	0.192(40)	0.103(21)	0.077(16)	0.0425(87)
125	0.59(12)	0.217(45)	0.109(22)	0.084(17)	0.0446(91)

240 in the energy range from 50 eV to 250 eV. The relative
 241 DCSs are measured as a function of scattering angle at
 242 fixed incident electron energies. The relative flow method
 243 is used for calibration of relative results on absolute
 244 scale, using argon as a referent gas. Experimental mea-
 245 surements are compared with the calculations, which are
 246 obtained using Independent Atom Model (IAM), and good
 247 agreement is noticed.

248 In an attempt to develop more efficient radiation-
 249 based technologies and for better comprehension of the
 250 radiation damage of biomolecules, a deeper understanding

251 of fundamental processes at the molecular level is needed,
 252 which implies electron interactions with molecules that
 253 form the medium. For this reason, the results from this
 254 paper can be of interest since they contribute to a funda-
 255 mental understanding of the electron interaction with a
 256 relatively large molecule.

257 This work has been supported by the MESTD of the Repub-
 258 lic of Serbia Grant #OI 171020. BPM acknowledges the
 259 grant of VAMDC consortium under open call 2016-1, project
 260 funded under the “Combination of Collaborative Projects and
 261 Coordination and Support Actions” Funding Scheme of The
 262 Seventh Framework Program. One of us KT was also sup-
 263 ported by the National Research, Development and Innovation
 264 Office (NKFIH) Grant KH126886, and by the European COST
 265 Action CA15107 (MultiComp).

266 Author contribution statement

267 Please note that you are required to include a state-
 268 ment which details the nature of the contribution of each
 269 author.

270 References

271 1. B. Boudaiffa, P. Cloutier, D. Hunting, M.A. Huels, L.
 272 Sanche, *Science* **287**, 1658 (2000)

2. C. Winstead, V. McKoy, S. d’A Sanchez, *J. Chem. Phys.* **127**, 085105 (2007) 273
3. J.B. Maljković, F. Blanco, R. Čurik, G. García, B.P. 274
 Marinković, A.R. Milosavljević, *J. Phys. Chem.* **137**, 275
 064312 (2012) 276
4. A.R. Milosavljević, F. Blanco, J.B. Maljković, D. Šević, G. 277
 García, B.P. Marinković, *New J. Phys.* **10**, 103005 (2008) 278
5. A.R. Milosavljević, A. Giuliani, D. Šević, M.J. Hubin- 279
 Franksin, B.P. Marinković, *Eur. Phys. J. D* **35**, 411 280
 (2005) 281
6. A.R. Milosavljević, F. Blanco, D. Šević, G. García, B.P. 282
 Marinković, *Eur. Phys. J. D* **40**, 107 (2006) 283
7. J.B. Maljković, A.R. Milosavljević, F. Blanco, D. Šević, G. 284
 García, B.P. Marinković, *Phys. Rev. A* **79**, 052706 (2009) 285
8. C. König, J. Kopyra, I. Bald, E. Illenberger, *Phys. Rev.* 286
Lett. **97**, 018105 (2006) 287
9. I. Bald, E. Illenberger, J. Kopyra, *J. Phys. Conf. Ser.* **373**, 288
 012008 (2012) 289
10. M.L. Ranković, J.B. Maljković, K. Tökési, B.P. 290
 Marinković, *Eur. Phys. J. D* **72**, 30 (2018) 291
11. J.F. Williams, B.A. Willis, *J. Phys. B* **8**, 1670 (1975) 292
12. D.R. Olander, J. Kruger, *J. Appl. Phys.* **41**, 2769 (1970) 293
13. M.G.P. Homem, I. Iga, R.T. Sugohara, I.P. Sanches, M.T. 294
 Lee, *Rev. Sci. Instr.* **82**, 013109 (2011) 295
14. A.R. Milosavljević, A. Giuliani, D. Šević, M.J. Hubin- 296
 Franksin, B.P. Marinković, *Eur. Phys. J. D* **35**, 411 297
 (2005) 298
15. F. Salvat, R. Mayol, *Comput. Phys. Commun.* **74**, 358 299
 (1993) 300

Uncorrected

Author Query

Q1 Please provide the author contribution statement.

Uncorrected Proof

EPJ D



Recognized by European Physical Society

Atomic, Molecular,
Optical and Plasma
Physics

Eur. Phys. J. D (2018) 72: 30

DOI: [10.1140/epjd/e2017-80677-4](https://doi.org/10.1140/epjd/e2017-80677-4)

Elastic electron differential cross sections for argon atom in the intermediate energy range from 40 eV to 300 eV

Miloš Lj. Ranković, Jelena B. Maljković, Károly Tökési, and Bratislav P. Marinković

 edp sciences



 Springer

Elastic electron differential cross sections for argon atom in the intermediate energy range from 40 eV to 300 eV^{*,**}

Miloš Lj. Ranković¹, Jelena B. Maljković¹, Károly Tökési^{2,3}, and Bratislav P. Marinković^{1,a}

¹ Institute of Physics Belgrade, University of Belgrade, Pregrevica 118, 11080 Belgrade, Serbia

² Institute for Nuclear Research, Hungarian Academy of Sciences (ATOMKI), Debrecen, Hungary

³ ELI-ALPS, ELI-HU Non-profit Kft., Szeged, Hungary

Received 25 October 2017 / Received in final form 29 November 2017

Published online 6 February 2018 – © EDP Sciences, Società Italiana di Fisica, Springer-Verlag 2018

Abstract. Measurements and calculations for electron elastic differential cross sections (DCS) of argon atom in the energy range from 40 to 300 eV are presented. DCS have been measured in the crossed beam arrangement of the electron spectrometer with an energy resolution of 0.5 eV and angular resolution of 1.5° in the range of scattering angles from 20° to 126°. Both angular behaviour and energy dependence of DCS are obtained in a separate sets of experiments, while the absolute scale is achieved via relative flow method, using helium as a reference gas. All data is corrected for the energy transmission function, changes of primary electron beam current and target pressure, and effective path length (volume correction). DCSs are calculated in relativistic framework by expressing the Mott's cross sections in partial wave expansion. Our results are compared with other available data.

1 Introduction

Electron elastic differential cross sections (DCS) of argon atom have been investigated thoroughly in the past by many experimental groups and different theoretical approaches but they still need further analysis and improvements. There are numerous reasons for this study: (i) DCS is still one of the stringiest test for electron–atom interaction that is energy (E_o) and angle (θ) dependent and where different theoretical approximations work adequately only in a certain (E_o, θ) domain. DCS is one of the variables in the “perfect scattering experiment” which has to be determined in absolute values in order to reproduce all complex scattering amplitudes [1]; (ii) Argon atom is often used as a model for both experimental (easy to handle, inexpensive in high purity) and theoretical (closed shell, many electron system) studies. Recently, Bartschat et al. [2] used an argon atom to make an overview on quantum-mechanical approaches for generating the electron–atom cross sections and to perform uncertainty estimates; (iii) atomic argon is an important model for the numerous calculation codes, now available, which use either quantum chemistry codes [3] or through other codes, like relativistic Dirac partial-wave analysis, incorporated into databases [4]; an important model for

all being argon atom; (iv) there is a need for accurate cross sections for argon atom in experiments that use relative flow method (RFM) to determine absolute values of DCS for more complex molecules [5]. One of the key requirements in RFM is to provide similar flowing conditions (special distributions) of the measured and reference gas. This is easier to achieve if the masses of gases are similar, hence Ar or N₂ gases are preferentially used as references rather than helium which has the best known literature values for DCSs; and (v) the authors want to extend previous DCS measurements on Ar (listed in Tab. 1 among the other e/Ar data).

The first measurements of the differential electron elastic scattering by argon atom include those performed in 1931 by Bullard and Massey [6] and by Arnot [7] where the angular distributions were obtained in the ranges 4–40 eV, 15°–125° and 42–780 eV, 20°–120°, respectively. A comprehensive review of later experimental and theoretical results on electron/Ar cross sections up to 1995 was given by Zecca et al. [8] and results up to 2002 were compiled by Raju [9]. A critical data evaluation and consistency of electron scattering by argon was made in 2008 by Gargioni and Grosswendt [10]. A comparison of sets of cross sections for electron scattering from ground-state Ar in the energy range from thermal to about 1 keV with the overview of cross sections maintained by LXCAT database is given in [11]. The most recent results are presented in Table 1. The present experiment covers the electron impact energy range from 40 eV to 300 eV and the scattering angles from 25° up to 126°, while calculations are performed in broader range of impact energies and for the full range of scattering angles.

* Contribution to the Topical Issue “Physics of Ionized Gases (SPIG 2016)”, edited by Goran Poparic, Bratislav Obradovic, Dragana Maric and Aleksandar Milosavljevic.

** Supplementary material in the form of one pdf file from the Journal web page at

<https://doi.org/10.1140/epjd/e2017-80677-4>.

^a e-mail: bratislav.marinkovic@ipb.ac.rs

Table 1. The latest experimental and theoretical work on DCS for elastic cross section for argon atom covering impact energy range from 40 to 300 eV.

Author	Type of experiment/ theoretical approach	Energy range (eV)	Angular range (°)
Paikeday and Alexander [12]	Model potential	20–500	0–180
Kelemen [13]	Optical potential	0.5–500	Spin polarisation 0–180
Blanco and García [14]	Quasifree nonempirical model	40–10 000	0–180
Blanco and García [15]	Quasifree nonempirical model	40–800	0–180
Salvat [16]	Optical-model potential	100–3000	0–180
Milosavljević et al. [17]	Crossed beams/ relativistic ab initio	40–150	40–126
Yousif Al-Mulla [18]	Local density approximations	10–100	0–180
Jablonski et al. [19]	Thomas–Fermi–Dirac/ Dirac–Hartree–Fock potential	50–3000	0–180
Adibzadeh and Theodosiou [20]	Relativistic/nonrelativistic phase shifts	5–1000	0–180
Hargreaves et al. [21]	Crossed beams (SSRDM)	20–50	20–135
McEachran and Stauffer [22]	Ab initio optical potential	40–100	0–180
Bote et al. [23]	Optical-model potential	10–3000	0–180

2 Experimental method and theoretical approach

2.1 Experimental set-up

The home-made experimental setup is based on a crossed-beam technique comprising of an electron gun, a single capillary gas needle and a detection system with single channel electron multiplier detector (channeltron). Detailed description of the original setup is given in [24,25], while construction of a gas line used for relative flow technique, design and programming of digital acquisition system are detailed in [5]. Briefly, electrons are produced from an indirectly heated thoriated tungsten hairpin filament (diameter 0.2 mm). Emitted electrons are then doubly focused by a 9 electrode system of the electron gun, including two axis deflector electrodes. The energy resolution of electrons at the exit of the electron gun is limited by a thermal distribution of emitted electrons to about 0.5 eV as there is no monochromaticity. The electron gun is mounted on a turntable and can be rotated in the plane of scattering from -40° to 126° around the fixed detection system. The angular resolution is estimated to about $\pm 1.5^\circ$, while the zero angle uncertainty is better than $\pm 0.25^\circ$ regarding the alignment and center precision of the entire system. The distance from the last electrode of the electron gun to the scattering centre (gas needle) is 30 mm, while the interaction volume is about 3 mm above the gas needle. The aspect ratio of the effusive beam capillary is 0.0125 with a length of 40 mm. The detection system consist of four electrode lens at the entrance of a double cylindrical mirror analyser (DCMA), three electrode lens at its exit and PHOTONIS X810BL channeltron enclosed in a shielded case. The first electrode of a four electrode lens is positioned 25 mm from the gas needle. Its function is to focus the scattered electrons and to apply the retarding potential such that electrons always have a fixed energy when entering DCMA. Therefore, DCMA is operated in a constant pass energy mode with an energy resolution down to about 0.4 eV.

2.2 Measurement procedure

DCS data as function of scattering angle, DCS (θ), is obtained by measuring the signal and background for each angle point. The signal measurement is performed first and is followed by background measurement, which involves the introduction of a target gas into the chamber from the side leak, whilst the signal is measured for target gas diverted through the gas needle. These two measurements were performed at least three times for each electron energy of interest. Subtracting the background from signal yields three corrected measurements which were weighted and averaged. For each electron energy, the analyser was set to allow the electrons corresponding to the elastic peak to pass through. Accordingly, the electron gun and two lenses before and after the analyser were readjusted for optimal signal and to compensate for the transmission functions.

DCS data as a function of electron energy, DCS (E_o), is obtained by fixing the angle and measuring the count for each energy point for at least three times. Prior to this measurement, the electron current in a Faraday cup as a function of electron energy was recorded, even though the electron gun was refocused. The transmission of the analyser system as a function of electron energy has been obtained from a simulation in SIMION8 [26], where optimal lens potentials were determined. These potentials were then used for the measurements and the obtained data was normalized to the simulated transmission. Additional normalization was performed to compensate for the small change in the gas needle pressure over time and measured electron current.

The relative flow measurements were taken for the needle pressure of about 0.373 mbar for Argon (target gas) and about 0.133 mbar for Helium (buffer gas). The ultimate base pressure in the experiment was about 5×10^{-7} mbar, while working pressure when both gasses were introduced in the chamber was in the order of 5×10^{-6} mbar. Each relative flow measurement was performed two times and the average values were taken for the normalization to absolute scale.

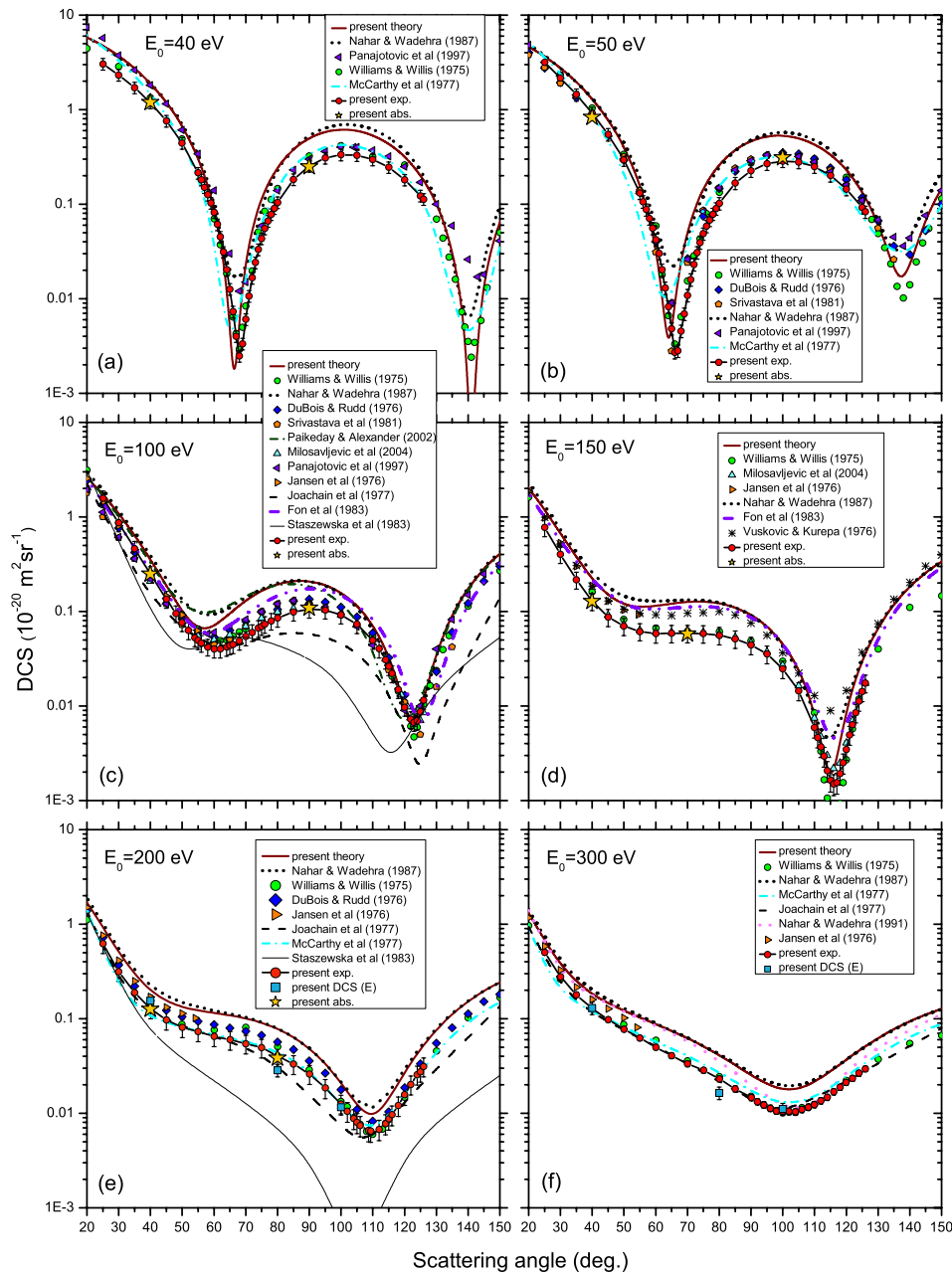

Fig. 1. Angular behaviour of differential cross section for elastic scattering of electrons on argon. The present experimental and theoretical data are compared with the selected set of previous results. The data symbols used correspond to: (red circles), present experiment; (yellow stars), present absolute data from relative flow; (dark cyan squares), present DCS (E); (dark red full line), present theory; (green circles), Williams and Willis [30]; (orange right triangles), Jansen et al. [31]; (asterisk); Vušković and Kurepa [32]; (blue diamond), DuBois and Rudd [33]; (dashed line), Joachain et al. [34]; (cyan dash dot line), McCarthy et al. [35]; (orange pentagons), Srivastava et al. [36]; (violet dash dot line), Fon et al. [37]; (thin line), Staszewska et al. [38]; (dotted line), Nahar and Wadehra [39]; (magenta short dash line), Nahar and Wadehra [42]; (violet left triangle), Panajotović et al. [44]; (olive dash dot line), Paikeday and Alexander [12]; (cyan up triangles), Milosavljević et al. [17].

2.3 Normalization and experimental uncertainties

The relative DCS data is made absolute by using the relative flow technique with Helium as a reference gas. Data for Helium was taken from Register et al. [27] and both DCS (θ) and DCS (E_o) were measured at least three times and the weighted average as well as weighted uncertainties were calculated. To this statistical

uncertainty, the instrumental uncertainties (effective path length correction, uncertainty in energy and angular scale) and the uncertainty from a normalization originating from the relative flow measurements and Helium data, specified by the authors, was added. The total uncertainties vary with impact electron energy and span from 14% at the lowest up to 22% for the highest impact energy.

Table 2. Experimental and theoretical DCS for elastic cross section for argon atom used for a comparison with present results.

Author	Type of experiment/ theoretical approach	Energy range (eV)	Angular range (°)
Williams and Willis [30]	Modulated crossed beam	20–400	20–150
Jansen et al. [31]	Gas cell	100–3000	5–55
Vušković and Kurepa [32]	Gas cell	60–150	5–150
DuBois and Rudd [33]	Gas cell	20–800	2–150
Joachain et al. [34]	Optical potential	100–800	
McCarthy et al. [35]	Optical potential	20–3000	
Srivastava et al. [36]	Crossed beams (RFM/He)	3–100	20–135
Fon et al. [37]	<i>R</i> -matrix	3–150	
Staszewska et al. [38]	Quasifree-scattering model/ optical-model potential (SEPa)	30–3000	
Nahar and Wadehra [39]	Model potential	3–300	
Salvat et al. [40]	Semiphenomenological approach	100–5000	
Bartschat et al. [41]	Optical potential method	15–100	
Nahar and Wadehra [42]	Relativistic Dirac equation	3–300	
Cvejanović and Crowe [43]	Crossed beams	20.4–110	40–120
Panajotović et al. [44]	Crossed beams	10.3–100.3	20–150

RFM/gas – relative flow method with gas used as a reference; SEP – static, exchange, polarisation, absorption potential.

2.4 Calculations

The partial expansion method was used to describe the differential and total cross sections for elastic scattering. The relativistic differential cross section per unit solid angle is given by sum of squares of the direct $f(\theta)$ and spin-flip $g(\theta)$ scattering amplitudes:

$$\frac{d\sigma_e}{d\theta} = |f(\theta)|^2 + |g(\theta)|^2, \quad (1)$$

where θ denotes the scattering angle $f(\theta) = \sum_{l=0}^{\infty} F_l P_l(\cos(\theta))$, $g(\theta) = \sum_{l=0}^{\infty} G_l P_l^1(\cos(\theta))$, $P_l(\cos(\theta))$ are the Legendre polynomials, $P_l^1(\cos(\theta))$ are the associated Legendre functions. F_l and G_l can be calculated as follows:

$$F_l = \frac{1}{2ik} \{ (l+1) [\exp(2i\delta_{l+}) - 1] + l [\exp(-2i\delta_{l-}) - 1] \}$$

$$G_l = \frac{1}{2ik} [\exp(2i\delta_{l-}) - \exp(-2i\delta_{l+})],$$

where δ_{l+} , δ_{l-} are the phase shift of the order l , and k is the momentum of the projectile electron. Details of the calculations can be found in reference [29]. The total elastic cross section, σ_T , can be obtained after integration over the all possible scattering angles as:

$$\sigma_T = 2\pi \int_0^\pi \frac{d\sigma_e(E_o, \theta)}{d\Omega} \sin \theta d\theta. \quad (2)$$

3 Results and discussion

3.1 Angular behaviour of differential cross sections, DCS (θ)

Differential cross sections for electron elastic scattering by argon atom, DCS (θ), at impact energies of 40, 50, 100, 150, 200 and 300 eV are shown in Figure 1. The present

experimental results are obtained from three separate sets of measurements: the direct angular distribution measurements over whole accessible angular range; data points at fixed angles derived from relative flow measurements with helium as a reference gas; and the direct measurements of energy dependence at fixed scattering angle. The first and third sets give the relative values, while the second set gives the absolute values. Relative sets are made absolute by fitting the curves to absolute data points by the least squares method. Present experimental and theoretical DCS are compared with other data listed in Table 2. Experimental values of DCS are tabulated in Table 3 with the quoted level of uncertainties.

The differential cross section at 40 eV exhibits two pronounced minima, at 68° and 142°. The excellent agreement between present measurements and former absolute measurements of Williams and Willis [30] is found. The value of the DCS at the first minimum is $(2.50 \pm 0.15) \times 10^{-23} \text{ m}^2/\text{sr}$ and is as low as reported in [30]. The position of the minimum also agrees with the measurements of Panajotović et al. [44], but their minimum is less pronounced. The difference could be due to the proximity of the critical point in argon (around $41.30 \pm 0.02 \text{ eV}$; $68.5^\circ \pm 0.3^\circ$ [44]), although even at the critical point, their minimal value is only $(6.1 \pm 1.3) \times 10^{-23} \text{ m}^2/\text{sr}$. This can indicate the importance of subtraction of the residual background gas obtained by diverting gas through a side leak, as explained in Section 2.2.

The present calculations have the best agreement with the calculations of Bartschat et al. [41] in both absolute values and positions and depth of minima. Calculated DCS first minimum is almost of the same absolute value, just shifted to lower scattering angle of 66.4° compared to the present measurements. The calculated values at smaller scattering angles are higher than the experimental results but agree with previous measurements in [44]. The

Table 3. Experimental DCS for elastic cross section for argon in units of $10^{-20} \text{ m}^2/\text{sr}$ with the relative uncertainties indicated for each impact energy.

Angle ($^\circ$)	$10^{-20} \text{ m}^2 \text{ sr}^{-1}$					
	40 eV	50 eV	100 eV	150 eV	200 eV	300 eV
25	3.051	3.172	1.57	0.7762	0.6212	0.504
30	2.328	2.17	0.869	0.4039	0.316	0.277
35	1.711	1.442	0.461	0.2168	0.1888	0.1794
40	1.185	0.919	0.248	0.1289	0.1273	0.128
45	0.762	0.5475	0.135	0.0872	0.0972	0.098
48			0.0952			
50	0.444	0.2956	0.0765	0.07	0.081	0.0776
52			0.063			
54			0.053			
55	0.215	0.1314	0.0495	0.0615	0.073	0.0625
56	0.182	0.1067	0.0462			
57	0.151	0.0878				
58	0.126	0.0705	0.0422			
59	0.103	0.0558				
60	0.0820	0.0421	0.0401	0.0585	0.0649	0.0501
61	0.0612	0.0301				
62	0.0452	0.0202	0.0402			
63	0.0313	0.0130				
64	0.0204	0.0083	0.042			
65	0.0126	0.0048	0.0436	0.0588	0.0599	0.0406
66	0.0073	0.0027	0.0449			
67	0.004	0.0028				
68	0.0025	0.0046	0.0489			
69	0.0034	0.0069				
70	0.0061	0.0109	0.0543	0.0588	0.0545	0.0334
71	0.0107	0.0159				
72	0.0166	0.0231	0.0601			
73	0.0242	0.0309				
74	0.0332	0.0393	0.0666			
75	0.0435	0.0488	0.0699	0.0583	0.0495	0.0285
76	0.0554	0.0586	0.0733			
77	0.0663	0.0682				
78	0.0782	0.0788	0.0792			
79	0.0908	0.0902				
80	0.105	0.1024	0.0855	0.0559	0.0404	0.0231
85	0.183	0.1672	0.0989	0.0515	0.0332	0.0181
90	0.253	0.2265	0.1059	0.0442	0.026	0.0146
92						0.0133
94						0.0123
95	0.309	0.2674	0.1036	0.0355	0.0186	
96						0.0113
98						0.0106
100	0.334	0.2863	0.092	0.0247	0.0126	0.0105
102					0.0105	0.0105
104					0.0088	0.0103
105	0.3295	0.2792	0.073	0.0145	0.008	
106					0.0074	0.011
108					0.0066	0.0116
110	0.297	0.249	0.0497	0.0059	0.0065	0.0124
111				0.0047		
112			0.0403	0.0037	0.0068	0.0136
113				0.003		
114			0.0308	0.0021	0.0078	0.0147
115	0.246	0.2018	0.0263	0.0016	0.0087	
116			0.0221	0.0015	0.0097	0.0168
117				0.0016		
118			0.015	0.0019	0.0121	0.0189
119				0.0025		

(continued...)

Table 3. (*continued...*)

Angle (°)	$10^{-20} \text{ m}^2 \text{ sr}^{-1}$					
	40 eV	50 eV	100 eV	150 eV	200 eV	300 eV
120	0.181	0.1446	0.0097	0.0035	0.0157	0.0212
121				0.005		
122			0.0073	0.0064	0.0202	0.0234
123			0.0067	0.0085		
124			0.007	0.0113	0.0257	0.0265
125	0.123	0.0927	0.0087	0.0142	0.0275	
126	0.113	0.083	0.0115	0.0175	0.0313	0.0295
Relative uncertainty (%)	14	15	20	20	21	22

local maximum around 100° is larger than other experimental values and calculations of McCarthy et al. [35] but it is close to the values of Nahar and Wadehra [39]. The second minimum is found at 141° and is much deeper than both calculated [35] and measured [30,44] values.

The present experimental DCS at 50 eV agrees perfectly with previous measurements [30,33,36,44] in the whole angular range. The position and the value of the first minimum at 67° is the same as in [30,36]. The second minimum is beyond the angular range of the present experiment. The calculated DCS at 50 eV matches the experimental values at smaller scattering angles but has the minimum at 64.1° . Again at local maximum, the DCS is larger and has the same value as in [39]. The positions of both minima are close to other calculations [35,39] but with smaller values.

There are many experiments and theories for 100 eV impact energy. All experiments have an excellent agreement, at local maximum of 90° with discrepancy within $\pm 15\%$. The present calculated values agree with other calculations [12,37,39] except when compared to calculations by Joachain et al. [34] whose values are smaller in the whole angular range. The values of the calculations of [34] agree very well with the present measurements at the position of the first minimum. The present calculated values in the range of the second minimum strongly agree with the previously measured values in our laboratory by Milosavljević et al. [24].

There are two sets of previously measured data for 150 eV: Jansen et al. [31]; Vušković and Kurepa [32]; and Milosavljević et al. [24]; Williams and Willis [30]. The main distinction is in the values of the plateau at around 70° where the DCS has a flexing point (the first minimum became very shallow at this energy) and the DCS values of the first group are larger for 60% than the values of the second group. Interestingly, the present calculated values and those in [39] are even larger (factor 2.14) and they better match the experiments of the first group [31,32] while the present experiment favors the second group of results [24,30]. At this impact energy the second minimum is within the accessible range of the present experiment and its position at 116° agrees well with [24,30] – the present calculation gives the position of 115.1° . Also, the values of present measurement and calculation agree very

well – in contrast with previous calculations [37,39] where the shallower minimum was obtained.

At 200 eV, the shapes and the values of all experiments and calculations, except for calculations by Staszewska et al. [38] and Salvat et al. [40], are virtually the same and all DCSs lay within $\pm 40\%$ band around mean value. For both impact energies of 200 eV and 300 eV, the present calculations agree excellently with calculations of [39] in the full angular range, but they exceed the experimental values. Inclusion of imaginary part in the Dirac potential brought the calculations at 300 eV in [42] in agreement with experimental values in the region of the minimum when compared to the previous nonrelativistic calculations of the same authors [39]. Still, these relativistic calculations are much higher than experiments at middle angles (50° – 80°) where they agree with the present calculations based on the Mott's cross sections.

3.2 Energy dependence of differential cross sections, DCS (E_o)

Differential cross sections dependence on the impact energy, DCS (E_o), at fixed scattering angles of 40° , 80° and 100° are presented in Figures 2a–2c, respectively. Two sets of present experimental points are shown: the direct energy scans corrected for the analyser transmission and primary beam current and the single data points of relative flow measurements where absolute scale was established by helium data comparison [27]. Present experimental data are compared with other direct energy scan measurements of Cvejanović and Crowe [43]. The excellent agreement is found for all three scattering angles at the overlapping energies (40–100 eV). It is worth noting that the absolute scale of these two measurements have been established in different way, in [43] data have been normalized to previous absolute data of Srivastava et al. [36] while the present data were normalized on reference helium gas data obtained in a separate set of present measurements.

Present calculations generally give larger cross sections than experimental measurements, particularly at 100° and energies above 100 eV. This could be due to the sensitivity of DCS (E_o) at this angle because of the proximity of the

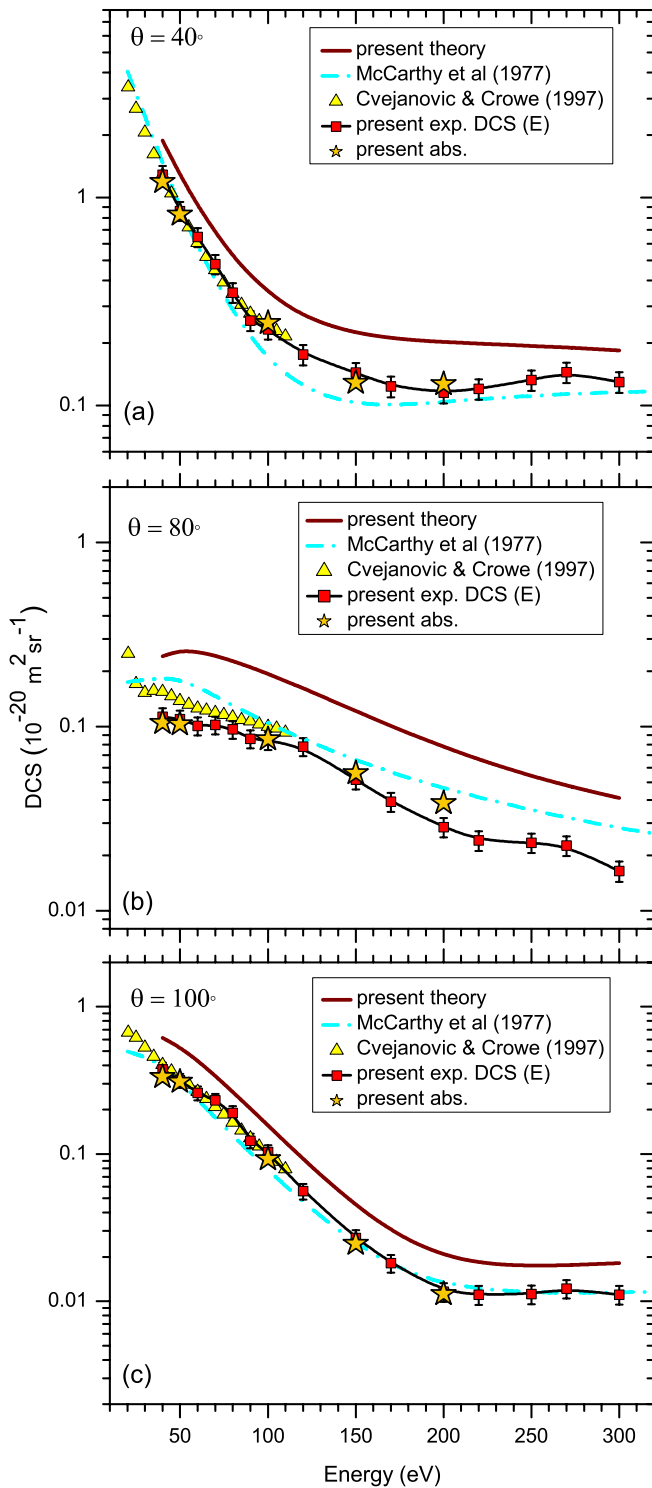

Fig. 2. Comparison of the present energy dependence of the differential cross section for elastic scattering of electrons on argon at a scattering angles of: (a) 40°; (b) 80° and (c) 100° with previous experimental and theoretical results. Error bars corresponding to the quoted uncertainties are presented on present data points. The data symbols used correspond to: (red squares), present experiment DCS (E); (yellow stars), present absolute data from relative flow; (dark red full line), present theory; (cyan dash dot line), McCarthy et al. [35]; (yellow up triangles), Cvejanović and Crowe [43].

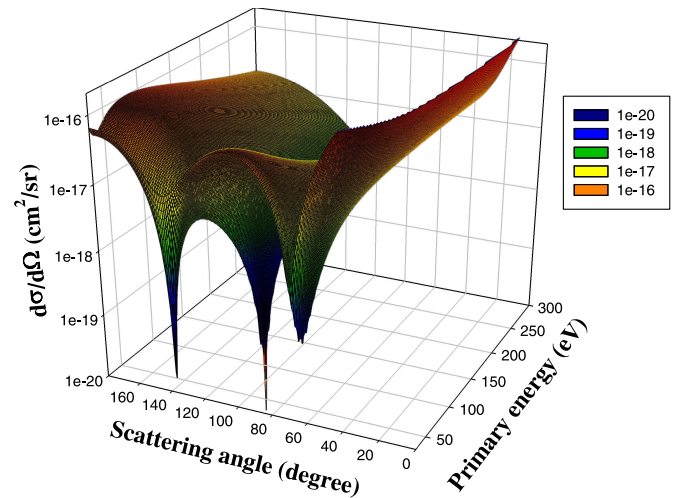

Fig. 3. Calculated differential cross section surface for electron elastic scattering by argon in the energy range from 40 to 300 eV. The full data set is given in the Supplementary material.

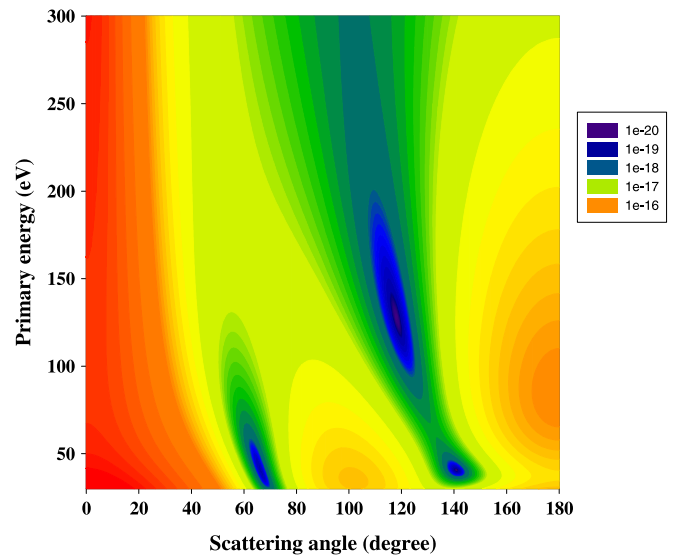

Fig. 4. Projection of 3D surface of elastic DCS for argon on the plane scattering angle – primary electron energy.

minimum point. The calculations of McCarthy et al. [35] agree better with the present measurements.

3.3 Differential cross section surface, DCS (E_o, θ), minima positions and critical points

It has been previously pointed out by Milosavljević et al. [25] that is of great importance to perform measurements of differential cross sections as independent energy and angular scans. This results in the whole DCS (E_o, θ) surface being cross-checked so that experimental errors could be avoided. These errors include energy transmissions of electron gun and analyser as well as misalignment

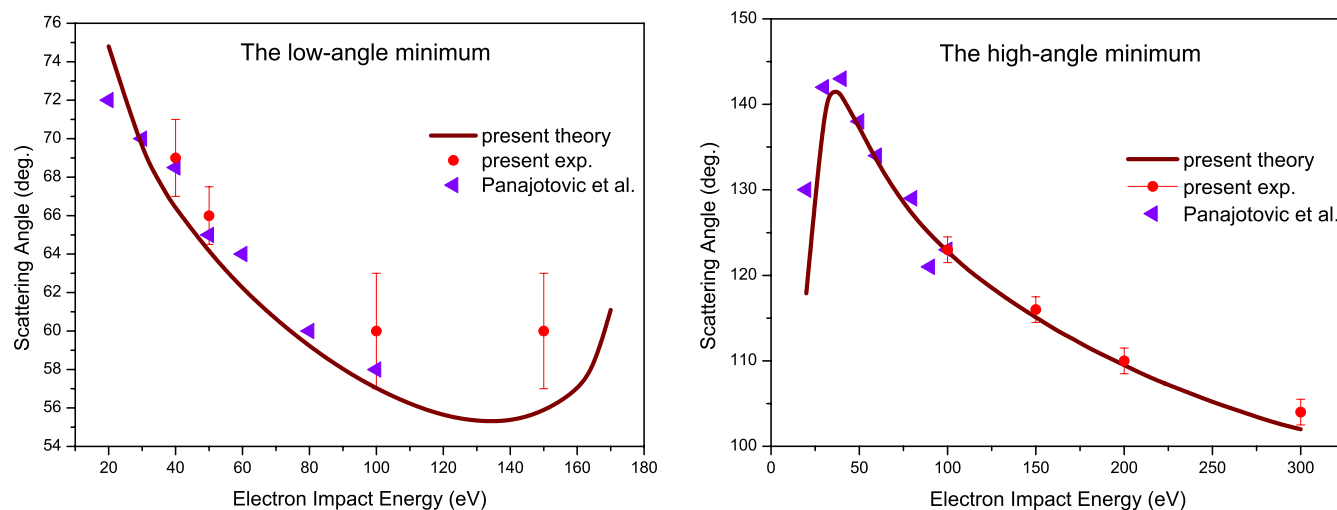

Fig. 5. Positions of low-angle and high-angle minima versus electron impact energy. The data symbols used correspond to: (red circles), present experiment; (dark red full line), present theory; (violet left triangle), Panajotović et al. [44].

of three axis, the primary beam axis, the target beam axis and the analyser axis.

In order to obtain the full 3D plot of the differential cross section surface it is necessary to calculate or measure differential cross sections on a rather dense grid, hence the present calculations being performed in angular steps of 0.1° and energy steps of 0.1 eV . The obtained surface is presented in Figure 3.

In the energy range from 30 to 300 eV differential cross sections show three critical points – places in 3D surface where DCS reach a minimum. The determination of these points is important as the critical minima represent a sensitive test of the interplay between direct and exchange potentials in electron interaction with the target atom. In the vicinity of critical minima the scattered electrons exhibit the largest change of the polarisation. Finding the pairs of incident energy and scattering angle where DCS minima attain their smallest values is a tedious task in experimental study and in the same time represents a crucial test of applied approximations in calculations. A detailed analysis of critical points in argon has been done by Lukas [45] and more recently by Sienkiewicz et al. [46] using ab initio relativistic calculations. Experimental values found in [44] are $(37.30 \pm 0.02\text{ eV}, 143.5^\circ \pm 0.3^\circ)$ and at $(41.30 \pm 0.02\text{ eV}, 68.5^\circ \pm 0.3^\circ)$ and the third minimum in [24] to be at $(129.4 \pm 0.5\text{ eV}, 119.4^\circ \pm 0.5^\circ)$. The present calculations also reveal the positions of three critical points clearly shown in Figure 4. Positions of critical minima in the present calculations are found to be: $(41\text{ eV}, 141^\circ)$, $(41\text{ eV}, 66^\circ)$ and $(128\text{ eV}, 118^\circ)$. It could be compared with the previous calculations in [46] $(39.3\text{ eV}, 68.0^\circ)$, $(39.5\text{ eV}, 141.0^\circ)$ and with calculations presented in [24] $(118.0\text{ eV}, 118.9^\circ)$.

The positions of low-angle and high-angle minima could also be traced with the change of impact electron energy. The calculated values for the first and the second minimum with experimental points at fixed energies are shown in Figures 5a and 5b, respectively.

4 Conclusions

Absolute measured and calculated differential cross sections for electron elastic scattering by argon atom are presented. Measurements have been taken in the energy range from 40 eV to 300 eV and for scattering angles from 25° to 126° , with smaller steps around minima positions. Calculations were performed using relativistic expression of a partial wave expansion method for electron–atom scattering using the Mott’s cross sections. Calculations have been performed in the energy range from 30 eV and for the full range of scattering angles, with the dense grid around critical points and positions of minima. The achieved agreement with other experiments and calculations is moderate and depends on impact energy and angular range. This indicates that advances in both experimental methods and applied theoretical approximations are required, despite the topic having been studied for a long time. It should not be forgotten that the differential cross sections and their absolute values are the crucial quantities in our quantum mechanical description of electron–atom interactions. We have achieved one of the goals, i.e. to provide a consistent set of data in this energy range that can be used in further experiments with other more complex targets, like biomolecules. All presented data, will be also maintained in the Belgrade electron/atom (molecule) database (BEAMDB) (<http://servo.aob.rs/emol>) [47].

We acknowledge the contribution of Drs. I. Čadež, S. Mandžukov and A.R. Milosavljević to the setting of the electron spectrometer UGRA at the Laboratory for Atomic Collision Processes, IPB. We are thankful to Dr. Andrew Cheesman for the critical reading of the manuscript. This work has been supported by the MESTD of the Republic of Serbia Grant #OI 171020. BPM acknowledges the grant of VAMDC consortium under open call 2016-1, project funded under the “Combination of Collaborative Projects and Coordination and

Support Actions” Funding Scheme of The Seventh Framework Program.

Author contribution statement

MLjR and JBM performed the experimental measurements, TK made all calculations, BPM, MLjR and TK wrote the manuscript. All authors discussed the results and commented on the manuscript.

References

1. N. Andersen, J.W. Gallagher, I.V. Hertel, *Phys. Rep.* **165**, 1 (1988)
2. K. Bartschat, J. Tennyson, O. Zatsarinny, *Plasma Process. Polym.* **14**, 1600093 (2017)
3. J. Tennyson, S. Rahimi, C. Hill, L. Tse, A. Vibhakar, D. Akello-Egwel, D.B. Brown, A. Dzarasova, J.R. Hamilton, D. Jaksch, S. Mohr, K. Wren-Little, J. Bruckmeier, A. Agarwal, K. Bartschat, A. Bogaerts, J.-P. Booth, M.J. Goeckner, K. Hassouni, Y. Itikawa, B.J. Braams, E. Krishnakumar, A. Laricchiuta, N.J. Mason, S. Pandey, Z.Lj. Petrović, Y.-K. Pu, A. Ranjan, S. Rauf, J. Schulze, M.M. Turner, P. Ventzek, J.C. Whitehead, J.-S. Yoon, *Plasma Sour. Sci. Technol.* **26**, 055014 (2017)
4. F. Salvat, A. Jablonski, C.J. Powell, A.Y. Lee, NIST Electron Elastic-Scattering Cross-Section Database Version 4.0, NIST Standard Reference Database Number 64, National Institute of Standards and Technology, Gaithersburg, MD, 20899 (2016), <https://srdata.nist.gov/srd64/> (retrieved 7/07/2017)
5. J.B. Maljković, A.R. Milosavljević, F. Blanco, D. Šević, G. García, B.P. Marinković, *Phys. Rev. A* **79**, 052706 (2009)
6. E.C. Bullard, H.S.W. Massey, *Proc. R. Soc. A* **130**, 579 (1931)
7. F.L. Arnot, *Proc. R. Soc. A* **133**, 615 (1931)
8. A. Zecca, G.P. Karwasz, R.S. Brusa, *R. Nuovo Cimento* **19**, 1 (1996)
9. G.G. Raju, *IEEE Trans. Dielectr. Electr. Insul.* **11**, 649 (2004)
10. E. Gargioni, B. Grosswendt, *Rev. Mod. Phys.* **80**, 451 (2008)
11. L.C. Pitchford, L.L. Alves, K. Bartschat, S.F. Biagi, M.C. Bordage, A.V. Phelps, C.M. Ferreira, G.J.M. Hagelaar, W.L. Morgan, S. Pancheshnyi, *J. Phys. B* **46**, 33009 (2013)
12. J.M. Paikeday, J. Alexander, *Int. J. Quant. Chem.* **90**, 778 (2002)
13. V. Kelemen, *Z. Techn. Phys.* **72**, 13 (2002)
14. F. Blanco, G. García, *Phys. Lett. A* **295**, 178 (2002)
15. F. Blanco, G. García, *Phys. Rev. A* **67**, 022701 (2003)
16. F. Salvat, *Phys. Rev. A* **68**, 012708 (2003)
17. A.R. Milosavljević, S. Telega, D. Šević, J.E. Sienkiewicz, B.P. Marinković, *Rad. Phys. Chem.* **70**, 669 (2004)
18. S.Y. Yousif Al-Mulla, *J. Phys. B* **37**, 305 (2004)
19. A. Jablonski, F. Salvat, C.J. Powell, *J. Electron Spectr. Rel. Phenom.* **137–140**, 299 (2004)
20. M. Adibzadeh, C.E. Theodosiou, *At. Data Nucl. Data Tabl.* **91**, 8 (2005)
21. L.R. Hargreaves, J.R. Francis-Staite, T.M. Maddern, M.J. Brunger, S.J. Buckman, *Meas. Sci. Technol.* **18**, 2783 (2007)
22. R.P. McEachran, A.D. Stauffer, *J. Phys. B* **42**, 075202 (2009)
23. D. Bote, F. Salvat, A. Jablonski, C.J. Powell, *J. Electron. Spectrosc. Relat. Phenom.* **175**, 41 (2009)
24. A.R. Milosavljević, S. Telega, D. Šević, J.E. Sienkiewicz, B.P. Marinković, *Eur. Phys. J. D.* **29**, 329 (2004)
25. A.R. Milosavljević, S. Madžunkov, D. Šević, I. Čadež, B.P. Marinković, *J. Phys. B* **39**, 609 (2006)
26. SIMION8 <http://simion.com/>
27. D.F. Register, S. Trajmar, S.K. Srivastava, *Phys. Rev. A* **21**, 1134 (1980)
28. R.T. Brinkmann, S. Trajmar, *J. Phys. E* **14**, 245 (1981)
29. F. Salvat, R. Mayol, *Comput. Phys. Commun.* **74**, 358 (1993)
30. J.F. Williams, B.A. Willis, *J. Phys. B* **8**, 1670 (1975)
31. R.H.J. Jansen, F.J. de Heer, H.J. Luyken, B. van Wingerden, H.J. Blaauw, *J. Phys. B* **9**, 185 (1976)
32. L. Vušković, M.V. Kurepa, *J. Phys. B* **9**, 837 (1976)
33. R.D. DuBois, M.E. Rudd, *J. Phys. B* **9**, 2657 (1976)
34. C.J. Joachain, R. Vanderpoorten, K.H. Winters, F.W. Byron Jr, *J. Phys. B* **10**, 227 (1977)
35. I.E. McCarthy, C.J. Noble, B.A. Phillips, A.D. Turnbull, *Phys Rev A* **15**, 2173 (1977)
36. S.K. Srivastava, H. Tanaka, A. Chutjian, S. Trajmar, *Phys. Rev. A* **23**, 2156 (1981)
37. W.C. Fon, K.A. Berrington, P.G. Burke, A. Hibbert, *J. Phys. B* **16**, 307 (1983)
38. G. Staszewska, D.W. Schwenke, D.G. Truhlar, *Int. J. Quant. Chem.* **17**, 163 (1983)
39. S.N. Nahar, J.M. Wadehra, *Phys. Rev. A* **35**, 2051 (1987)
40. F. Salvat, R. Mayol, J.D. Martinez, *J. Phys. B* **20**, 6597 (1987)
41. K. Bartschat, R.P. McEachran, A.D. Stauffer, *J. Phys. B* **21**, 2789 (1988)
42. S.N. Nahar, J.M. Wadehra, *Phys. Rev. A* **43**, 1275 (1991)
43. D. Cvejanović, A. Crowe, *J. Phys. B* **30**, 2873 (1997)
44. R. Panajotović, D.M. Filipović, B.P. Marinković, V. Pejèev, M. Kurepa, L. Vušković, *J. Phys. B* **30**, 5875 (1997)
45. C.B. Lukas, *J. Phys. B* **12**, 1549 (1979)
46. J.E. Sienkiewicz, S. Telega, P. Syty, S. Fritzsche, *Rad. Phys. Chem.* **68**, 285 (2003)
47. B.P. Marinković, D. Jevremović, V.A. Srećković, V. Vujèić, Lj.M. Ignjatović, M.S. Dimitrijević, N.J. Mason, *Eur. Phys. J. D* **71**, 158 (2017)



Article

Elastic Electron Scattering from Methane Molecule in the Energy Range from 50–300 eV

Jelena Vukalović^{1,2}, Jelena B. Maljković¹, Karoly Tökési³, Branko Predojević² and Bratislav P. Marinković^{1,*} 

¹ Institute of Physics Belgrade, University of Belgrade, Pregrevica 118, 11080 Belgrade, Serbia; jelena.vukovic@pmf.unibl.org (J.V.); jelenam@ipb.ac.rs (J.B.M.)

² Faculty of Science, University of Banja Luka, Mladena Stojanovića 2, 78000 Banja Luka, Republic of Srpska, Bosnia and Herzegovina; bpredojevic@teol.net

³ Institute for Nuclear Research (ATOMKI), 4026 Debrecen, Hungary; tokesi@atomki.hu

* Correspondence: bratislav.marinkovic@ipb.ac.rs; Tel.: +381-11-316-0882

Abstract: Electron interaction with methane molecule and accurate determination of its elastic cross-section is a demanding task for both experimental and theoretical standpoints and relevant for our better understanding of the processes in Earth's and Solar outer planet atmospheres, the greenhouse effect or in plasma physics applications like vapor deposition, complex plasma-wall interactions and edge plasma regions of Tokamak. Methane can serve as a test molecule for advancing novel electron-molecule collision theories. We present a combined experimental and theoretical study of the elastic electron differential cross-section from methane molecule, as well as integral and momentum transfer cross-sections in the intermediate energy range (50–300 eV). The experimental setup, based on a crossed beam technique, comprising of an electron gun, a single capillary gas needle and detection system with a channeltron is used in the measurements. The absolute values for cross-sections are obtained by relative-flow method, using argon as a reference. Theoretical results are acquired using two approximations: simple sum of individual atomic cross-sections and the other with molecular effect taken into the account.



Citation: Vukalović, J.; Maljković, J.B.; Tökési, K.; Predojević, B.; Marinković, B.P. Elastic Electron Scattering from Methane Molecule in the Energy Range from 50–300 eV. *Int. J. Mol. Sci.* **2021**, *22*, 647. <https://doi.org/10.3390/ijms22020647>

Received: 2 December 2020

Accepted: 1 January 2021

Published: 11 January 2021

Publisher's Note: MDPI stays neutral with regard to jurisdictional claims in published maps and institutional affiliations.



Copyright: © 2021 by the authors. Licensee MDPI, Basel, Switzerland. This article is an open access article distributed under the terms and conditions of the Creative Commons Attribution (CC BY) license (<https://creativecommons.org/licenses/by/4.0/>).

Keywords: methane; cross-section; elastic scattering; electrons

1. Introduction

Methane (CH₄) is the simplest alkane. Its molecule has tetrahedron shape, belongs to the T_d point group symmetry, and does not possess dipole and quadrupole moments. Furthermore, methane is widely distributed in the Solar System. In general, the inner planets Mercury [1], Venus [2], and Mars [3] are methane-poor, except Earth, whereas outer planets Jupiter [4], Saturn [5], Uranus [6], and Neptune [7] have methane-rich atmospheres. Currently, the methane levels in Earth's atmosphere are around 1.6–1.8 ppmv and are considered one of the main causes of the greenhouse effect. Greenhouse effect caused by methane is about eight times that of CO₂ [8]. Emission of CH₄ in atmosphere is about 40% from natural, and about 60% from anthropogenic sources (agriculture, energy, and waste sectors [9]). In past decades methane's growth rate was changing, and in recent years, it has been increasing [10]. That is a reason why investigation of this gas again becomes consequential.

Electron collisions with methane are very important in plasma physics. In mixture with hydrogen and argon, CH₄ is used for r. f. plasma-enhanced chemical vapor deposition (R. F. PECVD) of nanocrystalline diamond films [11]. On the other hand, methane is less used than silane in design of solar cells. Its use in the preparation of amorphous SiC *p*-layers is most often emphasized in a PECVD process using high R.F. power at relatively low temperature [12]. When a Tokamak is operated at high density and high temperature methane plays a dominant role in the edge plasma region [13]. Particles and energy are expelled from the plasma and are transported to the vessel wall, which leads to complex

plasma-wall interactions. These interactions create impurities in the plasma, including methane and its derivatives, resulting in significant cooling of plasma, which can prevent achievement of reactor relevant conditions. Therefore, understanding transport features of methane in plasma and interpretation of electron methane collisions in different physical processes plays a significant role in laboratory research in different fields of physics as well as in the investigation of properties atmospheres planets in Solar System. Finally, from a theoretical perspective and, because of its simplicity, methane can serve as a test molecule for advancing novel electron-molecule collision theories (e.g., Blanco et al. [14], Allan [15]).

Elastic electron scattering from methane molecule has been studied intensely in the past, and the most recent review of elastic differential cross-sections is given in [16]. Recommended set of data for electron/methane interactions is given by Song et al. [17]. For low incident electron energies (below 50 eV), elastic electron scattering from methane molecule has been studied experimentally and theoretically equally extensively. To cite few most recent papers, Allan [15] measured absolute differential elastic (impact electron energies 0.4–20 eV) and vibrational excitation cross-sections using an electron spectrometer with a magnetic angle changer, which allows measurements of differential cross-sections (DCSs) for backward angles. Bettega et al. [18] calculated DCSs and integral cross-sections (ICSs) for energies between 3 and 10 eV, using Schwinger multichannel method with pseudopotentials. Bundschu et al. [19] presented both experimental and theoretical results; measurements of DCSs using crossed beam apparatus and relative flow method, with He as a reference gas, and calculations using a body-fixed, single-center for close-coupled equations. Shyn and Cravens [20] reported DCSs for methane in energy range from 5 to 50 eV, using modulated crossed-beam method and He as reference gas for normalizing relative data to the absolute scale. At even lower electron energies, from 0.1 to 1.8 eV, an important study was one by Sohn et al. [21] where the references from even earlier measurements and calculations can be found. Several authors used R-matrix method to calculate cross-sections from methane [22–24].

As for papers that contain data for DCSs at intermediate-to-high energies ($E_0 \geq 50$ eV); Boesten and Tanaka [25] reported measured DCSs (electron energies between 1.5 and 100 eV), ICSs, and momentum transfer cross-sections (MTCs) for methane. Measurements were done using crossed electron and molecular beam technique where observed DCSs were normalized point by point with the help of simultaneous measurements of DCSs of He. Vušković and Trajmar [26] obtained relative cross-sections for 20, 30, and 200 eV impact energies and normalized them to the absolute measurements of Tanaka et al. [27] for 20 and 30 eV, and to the calculations of Dhal et al. [28] for 200 eV. Cho et al. [29] published measured data for DCSs (ICSs and MTCs as well) for electron elastic scattering from methane over scattering angles between 10° and 180° for incident electron energies from 5 to 100 eV using crossed beam spectrometer combined with a magnetic angle-changing device. Relative flow with He was exploited for normalization. They used the iterative Schwinger variational method combined with distorted-wave approximation to solve scattering equations. Sakae et al. [30] measured DCSs using crossed-beam method in angular range $5\text{--}135^\circ$ for electron energies 75–700 eV. Relative DCSs were converted to the absolute values at 30° by using the ratio of elastic DCSs of the target gas to that of He. Iga et al. [31] used crossed beam apparatus to obtain scattering intensities (100–500 eV incident electron energies), which were converted to the absolute scale using relative flow method (Ne was used as a reference gas). Also, they used Schwinger variational method combined with the distorted-wave approximation to study elastic electron scattering (1–500 eV) theoretically. Jain [32] used a spherical optical complex potential model to investigate electron interaction with methane over a wide energy range from 0.1 to 500 eV. Mahato et al. [33] obtained analytical expressions for the static potentials of electron scattering from methane using Gaussian wave functions and studied elastic scattering from 10 to 500 eV incident electron energies utilizing those static potentials along with exchange and polarization potentials. Song et al. [17] presented recommended elastic DCSs and ICSs obtained by averaging other authors' data [15,19–21,25,29–31]. List of experimental

and theoretical work on DCS for elastic electron scattering from methane molecule, in energy range of our interest is shown in Table 1. For the present work, the paper by Fuss et al. [34] is interesting because they provided the recommended set of data for differential and integral cross-sections for methane, including elastic electron scattering. They obtained their dataset by merging and averaging other authors' data [19,25,30,33] for lower energies and calculating ones for high energies (40–10 keV).

Table 1. List of experimental and theoretical work on differential cross-section (DCS) for elastic scattering of electrons from methane molecule, covering energy range from 50 to 300 eV.

Authors	Experiment Type with Normalization Method/Theoretical Approach	Energy Range (eV)	Angular Range (°)
Boesten and Tanaka [25]	Crossed beams, simultaneous measurements of DCS of He	1.5–100	10–130
Vušković and Trajmar [26]	Crossed beams, normalized to other authors results	20–200	8–130
Cho et al. [29]	Crossed beams, relative flow (He)/Schwinger variational method	5–100	10–180
Sakae et al. [30]	Crossed beams, relative flow (He)	75–700	5–135
Iga et al. [31]	Crossed beams, relative flow (Ne)/Schwinger variational method	100–500/ 1–500	10–135
Jain [32]	Spherical optical complex potential model	0.1–500	0–180
Mahato et al. [33]	Gaussian wave functions	10–500	0–180
Fuss et al. [34]	Optical potential method and the independent atom approximation including the screen corrected additivity rule (SCAR)	0.7–10,000	0–180

In this paper, theoretical and experimental results for elastic electron scattering from methane are shown. Obtained data include absolute differential cross-sections (DCSs) for elastic scattering for the incident electron energy range from 50 to 300 eV (with 50 eV steps) and angular range from 5° to 125° (with 5° steps), integral cross-sections, and momentum transfer cross-sections (ICSs and MTCSs, respectively) for every measured energy. The experiment was performed on a crossed-beam apparatus. As in most previous experiments [19,20,29–31], relative intensities were put on the absolute scale with help of relative flow method. The difference was in reference gas; in almost all experiments, He was used (except for Iga et al. [30] who used Ne), in our argon was reference gas. Theoretical results were obtained by calculating atomic cross-sections for molecular components, with two approximations used for molecular cross-sections simulations; simple sum (model 1) of atomic cross-sections and with molecular effect taken into the account (model 2). The existing variety of cross-section datasets for methane reflects our motivation to perform this study and, at the same time, to provide data at some of the impact energies where there are no previously measured data or where data require an independent confirmation. By exploiting different reference gas, Ar in this case, and performing new calculations that are using a coherent sum of atomic wave functions, we provide the independent and excessive datasets of cross-sections for this important molecule.

The paper is organized as follows. Theory and calculations of DCSs are explained in Section 2. Experimental setup and measurement procedure are given in Section 3. The obtained results are listed in Table 2 and presented graphically, including the comparison with the existing experimental and theoretical data, all given in Section 4. A discussion is given in Section 5. Finally, Section 6 is reserved for the conclusion.

Table 2. Experimental DCSs, integral cross-sections (ICSs), and momentum transfer cross-sections (MTCSs) for elastic scattering of electrons from methane molecule with absolute uncertainties Δ given in parentheses with 2 last digits. Values from 25° to 125° are measured and uncertainties arise from both statistical and short-term stability and include absolute uncertainties of cross-sections for reference Ar gas. Values from 0° to 20° and from 125° to 180° are extrapolated values and used to calculate ICSs and MTCSs. Uncertainties at small scattering angles are estimated to be 30%.

θ ($^\circ$)	DCS ($10^{-20} \text{ m}^2 \text{ sr}^{-1}$)					
	50 (eV)	100 (eV)	150 (eV)	200 (eV)	250 (eV)	300 (eV)
0	17.5(5.3)	19.3(5.9)	25.1(7.9)	24.0(7.4)	24.5(7.0)	23.4(6.6)
5	13.8(4.1)	13.2(4.0)	15.8(4.7)	13.5(4.1)	12.9(3.9)	11.0(3.3)
10	9.8(2.9)	7.9(2.5)	7.9(2.5)	6.1(1.9)	5.0(1.4)	3.9(1.1)
15	6.3(1.9)	3.9(1.2)	3.2(1.0)	2.43(0.76)	1.50(43)	1.07(30)
20	3.7(1.1)	1.70(53)	1.09(35)	0.83(0.26)	0.43(12)	0.435(78)
25	1.96(60)	0.98(30)	0.45(14)	0.39(12)	0.325(93)	0.277(78)
30	1.30(40)	0.61(19)	0.277(87)	0.246(76)	0.200(57)	0.181(51)
35	0.73(22)	0.40(12)	0.194(61)	0.175(54)	0.136(39)	0.128(36)
40	0.50(12)	0.288(89)	0.162(51)	0.132(41)	0.106(22)	0.100(20)
45	0.384(88)	0.230(55)	0.127(31)	0.105(25)	0.072(15)	0.058(12)
50	0.302(70)	0.174(41)	0.090(22)	0.072(17)	0.053(11)	0.0423(85)
55	0.249(57)	0.128(30)	0.061(15)	0.055(13)	0.0413(85)	0.0347(70)
60	0.206(47)	0.091(22)	0.047(12)	0.044(10)	0.0324(67)	0.0264(53)
65	0.173(40)	0.068(16)	0.0398(99)	0.0362(88)	0.0271(57)	0.0214(43)
70	0.144(33)	0.055(13)	0.0340(84)	0.0306(74)	0.0229(48)	0.0186(38)
75	0.111(26)	0.0451(11)	0.0305(76)	0.0291(71)	0.0211(44)	0.0154(31)
80	0.092(21)	0.0409(98)	0.0283(70)	0.0252(61)	0.0181(38)	0.0120(25)
85	0.072(17)	0.0381(93)	0.0284(71)	0.0244(59)	0.0145(31)	0.0107(22)
90	0.067(16)	0.0403(96)	0.0263(66)	0.0212(52)	0.0121(26)	0.0096(20)
95	0.062(14)	0.043(10)	0.0274(68)	0.0195(48)	0.0120(26)	0.0088(18)
100	0.061(14)	0.047(11)	0.0256(64)	0.0183(45)	0.0118(26)	0.0088(18)
105	0.066(15)	0.049(12)	0.0252(63)	0.0185(45)	0.0106(23)	0.0085(18)
110	0.078(18)	0.051(12)	0.0250(62)	0.0160(39)	0.0099(22)	0.0078(16)
115	0.087(20)	0.057(14)	0.0250(62)	0.0154(38)	0.0094(21)	0.0078(16)
120	0.102(24)	0.061(15)	0.0260(65)	0.0155(38)	0.0092(20)	0.0073(15)
125	0.118(27)	0.063(15)	0.0264(66)	0.0141(35)	0.0092(20)	0.0075(16)
130	0.136(31)	0.066(16)	0.0258(63)	0.0139(35)	0.0092(20)	0.0072(15)
140	0.176(41)	0.071(17)	0.0249(61)	0.0140(35)	0.0091(20)	0.0066(14)
150	0.230(53)	0.074(18)	0.0244(61)	0.0142(35)	0.0089(20)	0.0061(13)
160	0.311(72)	0.077(18)	0.0243(61)	0.0144(36)	0.0086(19)	0.0059(12)
170	0.44(10)	0.079(19)	0.0243(61)	0.0144(36)	0.0084(19)	0.0058(12)
180	0.67(15)	0.079(19)	0.0243(61)	0.0145(36)	0.0083(19)	0.0057(12)
ICS's	6.1(1.8)	3.8(1.2)	2.95(0.92)	2.37(0.74)	1.89(0.55)	1.56(0.47)
MTCS's	2.09(0.53)	0.98(0.26)	0.45(0.13)	0.33(0.10)	0.222(0.054)	0.177(0.043)

2. Theory

In this work, the key to the determination of the elastic cross-section calculations of CH_4 is the atomic cross-section calculations for the components of the molecule. We assume for the determination of the effective interaction at distance \mathbf{r} between a projectile electron and the target that the scattering potential can be expressed as:

$$V(r) = V_{\text{st}}(r) + V_{\text{ex}}(r) + V_{\text{cp}}(r), \quad (1)$$

where V_{st} is the electrostatic potential, V_{ex} is the electron exchange potential and V_{cp} is the correlation-polarization potential. The electrostatic potential for the interaction between an electron and the target atoms:

$$V_{\text{st}}(r) = -e[\varphi_{\text{n}}(r) + \varphi_{\text{e}}(r)], \quad (2)$$

where φ_n and φ_e are respectively the components of nucleus and the electron cloud of electrostatic potential.

The Furness-McCarthy exchange potential [35] is used for the electron exchange potential:

$$V_{\text{ex,FM}}(r) = \frac{1}{2}[E - V_{\text{st}}(r)] - \frac{1}{2}\{[E - V_{\text{st}}(r)]^2 + 4\pi a_0 e^4 \rho_e(r)\}^{1/2}. \quad (3)$$

An accurate correlation-polarization potential combines the long-range polarization potential, $V_{\text{cp,B}}(r)$, with the correlation potential $V_{\text{cp}}(r)$ obtained from the local-density approximation (LDA) and it can be expressed as [36]:

$$V_{\text{cp,LDA}}(r) \equiv \begin{cases} \max\{V_{\text{cp}}(r), V_{\text{cp,B}}(r)\}, & r < r_{\text{cp}} \\ V_{\text{cp,B}}(r), & r \geq r_{\text{cp}} \end{cases}. \quad (4)$$

where r_{cp} is the outer radius at which $V_{\text{cp}}(r)$ and $V_{\text{cp,B}}(r)$ cross. The $V_{\text{cp,B}}(r)$ when the projectile is far from the atom can be approximated by the Buckingham potential as:

$$V_{\text{cp,B}}(r) = -\frac{\alpha_d e^2}{2(r^2 + d^2)^2}, \quad (5)$$

where α_d is dipole polarizability of the target atom and d is a phenomenological cut-off parameter that serves to prevent the polarization potential from diverging at $r = 0$. The experimental values of the atomic dipole polarizabilities from [37] are usually used in Equation (5). Perdew and Zunger [38] proposed a parameterization of the $V_{\text{cp}}(r)$ correlation potential in the following form:

$$V_{\text{cp}}(r) = \begin{cases} -\frac{e^2}{a_0}(0.0311 \ln r_s - 0.0584 + 0.00133r_s \ln r_s - 0.0084r_s), & r_s < 1; \\ -\frac{e^2}{a_0} \frac{0.1423 + 0.1748r_s^{1/2} + 0.0633r_s}{(1 + 1.0529r_s^{1/2} + 0.3334r_s)^2}, & r_s \geq 1. \end{cases} \quad (6)$$

where

$$r_s = \frac{1}{a_0} \left[\frac{3}{4\pi\rho_e(r)} \right]^{1/3} \quad (7)$$

is the radius of the sphere that contains (on average) one electron of the gas, in units of the Bohr radius a_0 .

For the theoretical determination of the elastic cross-sections we used the Mott's differential cross-section [39],

$$\frac{d\sigma_e}{d\Omega} = |f(\theta)|^2 + |g(\theta)|^2, \quad (8)$$

where θ is scattering angle, $f(\theta)$ and $g(\theta)$ are the spin-up and spin-down scattering amplitudes. The $f(\theta)$ and $g(\theta)$ can be expressed as:

$$f(\theta) = \sum_{l=0}^{\infty} F_l P_l(\cos\theta), \quad (9)$$

$$g(\theta) = \sum_{l=0}^{\infty} G_l P_l^1(\cos\theta), \quad (10)$$

where $P_l(\cos\theta)$ are the Legendre polynomials, $P_l^1(\cos\theta)$ are the associated Legendre functions. The F_l and G_l can be calculated according to following relations:

$$F_l = \frac{1}{2ik} \left\{ (\ell + 1) (e^{2i\delta_\ell^+} - 1) + \ell (e^{2i\delta_\ell^-} - 1) \right\}; \quad (11)$$

$$G_l = \frac{1}{2ik} \sum_{\ell=1}^{\infty} \left\{ e^{2i\delta_\ell^-} - e^{2i\delta_\ell^+} \right\}, \quad (12)$$

where δ_ℓ^+ and δ_ℓ^- are spin up and spin down phase shifts of the ℓ th partial wave, and k is the momentum of the projectile electron, respectively.

The integration of the differential cross-section over total solid angles gives us the total elastic cross-sections in the following form:

$$\sigma_e = \int \frac{d\sigma_e}{d\Omega} d\Omega = 2\pi \int_0^\pi \sin\theta \left\{ |f(\theta)|^2 + |g(\theta)|^2 \right\} d\theta. \quad (13)$$

All calculations of elastic cross-section were performed by ELSEPA [40]. We used two approximations during the simulation of the molecular elastic cross-sections. In model 1, the calculated atomic cross-sections were simply added according to the stoichiometry numbers (additivity approximation). This approximation is frequently used approximation. However, it neglects the chemical-binding and aggregation effects. The electron distribution in molecules differs from that of an isolated atom of the same element. It was shown that this difference seems to have only a weak influence on the elastic DCS [40] at projectile energies larger than a few hundred eV. The effect of aggregation, the effect when the atoms are close together, has a stronger influence on the DCS [40]. In model 2 we have taken into account the positions of the atoms in the molecule. We used a single-scattering independent-atom approximation assuming that the interaction of the projectile with each atom of a molecule is given by the free-atom potential as for model 1. To determine the molecular DCS, the scattered wave at large distances from the molecule is approximated as the coherent sum of the wave functions scattered from all atoms in the molecule. In our calculations the carbon atom is located at the origin of the coordinate system. The positions of the hydrogen atoms are located at the following coordinates expressed in units of 10^{-10} m: $H_1(0.5541, 0.7996, 0.4965)$, $H_2(0.6833, -0.8134, -0.2536)$, $H_3(-0.7782, -0.3735, 0.6692)$, $H_4(-0.4593, 0.3874, -0.9121)$. We found the significant improvement in the cross-section calculations for model 2 compared with model 1.

3. Experiment

Experimental results presented in this paper are obtained on apparatus with crossed beams setting; incident electrons collide with a molecular beam perpendicularly. The experimental setup is placed inside the vacuum chamber, pumped with a turbomolecular pump to a typical background pressure (no gas in the chamber) about 5×10^{-7} mbar. The magnetic field in the collision region is reduced by two concentric μ -metal shields inside the chamber.

Incident electrons are derived from the hairpin tungsten filament (cathode) by thermoelectronic emission. The electron beam is then extracted and focused into the interaction volume by seven electrodes of the electron gun. Electron energy can vary in the range from 40 to 300 eV and is determined by the potential difference between the filament and the last, grounded, electrode, with energy resolution about 0.5 eV. When the current through the cathode filament was about 2.22 A, the electron current, measured with the Faradays cup without gas in the chamber, was approximately 100 nA. The electron gun can be rotated around the fixed detection system in the angular range from -40° to 126° .

Atomic/molecular beam is formed by stainless-steel gas needle. The length of the needle is $l = 40$ mm and its diameter, $d = 0.5$ mm. According to Lucas [40], beam properties can be predicted and optimized. Optimum atomic beam is obtained when $I(0)^2/(NH^2)$, where $I(0)$ is axial intensity, N throughput and H beam halfwidth, is maximum. It is shown that $I(0)^2/(NH^2) \propto l^2/d$ [41]. So, the optimum beam is acquired when the ratio of square of single tube length and its diameter is maximum, which is in our case 3200. These expressions can be employed for tubes where $\gamma = d/l$ (true dimensionless ratio of length and diameter) is below 10 ($\gamma < 10$) and gas pressure is low enough so that the mean free path of a particle is larger or equal than d ($\lambda \geq d$). In our experimental setup $\gamma = 80$ and $\lambda \approx d$.

After the interaction with the molecular beam, scattered electrons are entering the detection system. First, they are focused and slowed down to the constant pass energy of the analyzer by the four-electrode lens. Then, they are energy-analyzed by the double cylindrical mirror analyzer (DCMA). After that, elastically scattered electrons are focused by the three-electrode lens into the detector (single channel electron multiplier).

The intensity of elastically scattered electrons from methane molecule is measured as a function of scattering angle, from 25° to 125° (in 5° steps), at given incident electron energy, from 50 to 300 eV (in 50 eV steps). Experimental parameters were adjusted so that the interaction volume was kept constant. Deviations that can occur at small angles are corrected by comparing cross-sections from Ar at given energy with other authors' data [42,43]. During the measurements, working pressure in the chamber was about 4×10^{-6} mbar. For each electron energy, scattering intensities are measured at least three times. To discount background scattering contributions, a gas beam was introduced to the chamber through a side leak, away from the collision area. Scattering intensities are measured and subtracted from apparent signal for each angle.

The obtained relative DCSs are converted to the absolute DCSs using relative flow method (RFM) [44]. Briefly, the signal of scattered electrons from the target molecule is compared with elastically scattered electron intensity from reference gas, at the same scattering angle, for the same electron energy and experimental conditions. The same experimental conditions for both gasses implies that their beam profiles must be closely equal, which is acquired, according to Olander and Kruger [45], under two conditions: the mean free paths (λ) behind the gas needle for both gasses must be the same and the Knudsen number, K_L , defined as λ/l , must be in the appropriate range, $\gamma \leq K_L \leq 10$. The first condition is fulfilled when pressure ratio of test molecule and reference gas is inversely proportional to the ratio of squares of their gas kinetic diameters. In this study, Ar is used as a reference, with its diameter of approximately 3.58 Å. The gas kinetic diameter of the target gas, methane is approximately 3.8 Å, which gives ratio 1.13; almost the same gas pressure behind gas needle for both gasses must be applied. As for the second condition, gas pressures were low enough so that K_L is approximately equal to γ , although some studies have shown that even when K_L is much lower than γ , beam profiles for most gasses can still be very alike [46,47]. Besides scattering intensities of both gasses, relative flow rate is determined by measuring pressure increase in time by admitting gas into the constant volume, while a chamber outlet was closed.

The known absolute DCSs for Ar are taken from Ranković et al. [42] for incident electron energies 50–200 eV and 300 eV and from Williams and Willis [43] for electron energy of 250 eV. In both papers, the absolute values were derived by measurements of angular dependences of elastically scattered electrons using electron spectrometers, two 127° cylindrical electrostatic energy analyzer in [43], and a double cylindrical mirror analyzer in [42] but employing different normalization procedures. While in [42] the relative flow method with He as a reference gas was used, in [43] a phaseshift analysis of the relative angular distributions of electrons elastically scattered in the energy region of the resonances $^2P_{3/2,1/2}$ of Ar, i.e., between 11.0 and 11.4 eV, were used. Nevertheless, the absolute DCS values for Ar agree within mutual uncertainties as discussed in [42]. Since our normalization is based upon relative flow method, we prefer to use values from the most recent paper [42] and only for the energy of 250 eV, which is not available in [42] we used those from [43].

Since our experimental DCSs are obtained in the limited angular range, in order to obtain elastic integral (ICSs) and momentum transfer (MTCs) cross-sections, our DCSs must be extrapolated to the smallest (0°) and the highest (180°) scattering angles. Our extrapolation takes into account the theoretically obtained shapes of DCSs (present model 2, at small (0 – 25°) and high (120 – 180°) scattering angles and present experimental values

of DCSs near 25° and 120°. Thereafter, ICSs and MTCs were obtained using extrapolated DCSs and appropriate integration defined as:

$$ICS = 2\pi \int_0^{\pi} DCS(\theta) \sin \theta d\theta \quad (14)$$

$$MTCs = 2\pi \int_0^{\pi} DCS(\theta)(1 - \cos \theta) \sin \theta d\theta \quad (15)$$

The uncertainties of the relative DCSs consisted of statistical uncertainties and short-term stability uncertainties, caused by instability of the system. This uncertainty is increased by 20% for small scattering angles, due to the potential alteration of the interaction volume. Dominant uncertainties for absolute DCSs are those from reference cross-sections for Ar [42,43], and are taken to be about 20%. The DCS uncertainties obtained in such a manner, Δ , are presented in parenthesis within Table 2. The total uncertainties for absolute DCSs are about 30% for small angles and about 20% for the rest of the angular range. The total uncertainties of ICSs and MTCs arise from the DCSs uncertainties mentioned above and uncertainties of the extrapolation of DCSs to 0° and to 180° and numerical integration (10%).

4. Results

Measured results of the absolute differential cross-sections, integral cross-sections, and momentum transfer cross-sections, together with their corresponding uncertainties, are shown in Table 2. The results cover six incident electron energies, from 50 eV to 300 eV and angular range from 25° to 125°. In Figure 1, the present theoretical and experimental DCSs for all six incident electron energies are shown graphically. For the sake of comparison, other authors' data [16,23,24,27–31], listed in Table 1, are shown in the same figure.

Theoretical results are shown in two approximations: the simple sum of individual atomic cross-sections (model 1, dashed black line) and with molecular effects taken into account (model 2, solid black line). It can be seen that those effects significantly modify DCSs. One of them, the absorption potential, plays a dominant role in this modification of cross-sections. In comparison with present experiment and other authors' results, theory with included molecular effects showed better agreement, both qualitatively and quantitatively, as expected.

Obtained ICSs, together with other authors' results [17,25,29–31,33,34], are presented in Figure 2.

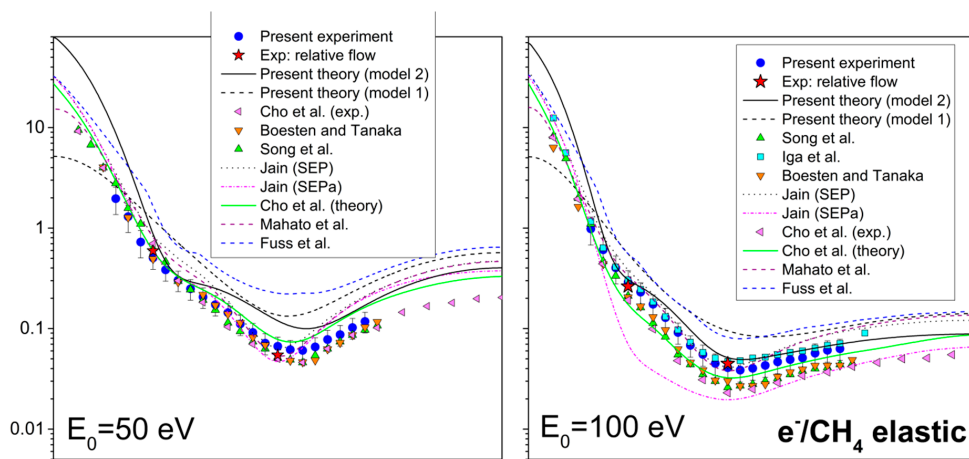

Figure 1. Cont.

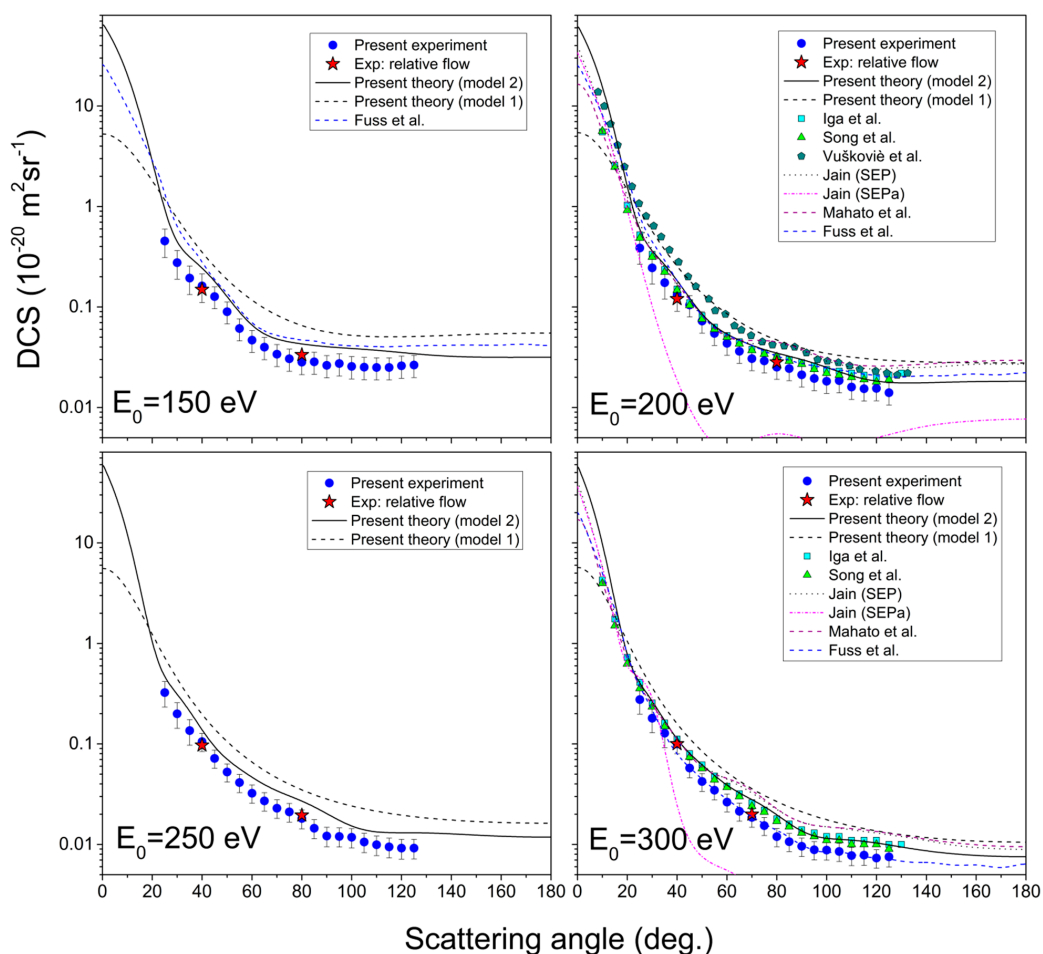

Figure 1. Angle differential cross-sections for elastic electron scattering from methane molecule, for six incident electron energies, from 50 eV to 300 eV. The present results include experiment (blue circles), relative flow absolute data (red stars), theory with molecular effects (full line) and simple sum theory (dashed line). Previous results, tabulated in Table 1, are also shown for the sake of comparison.

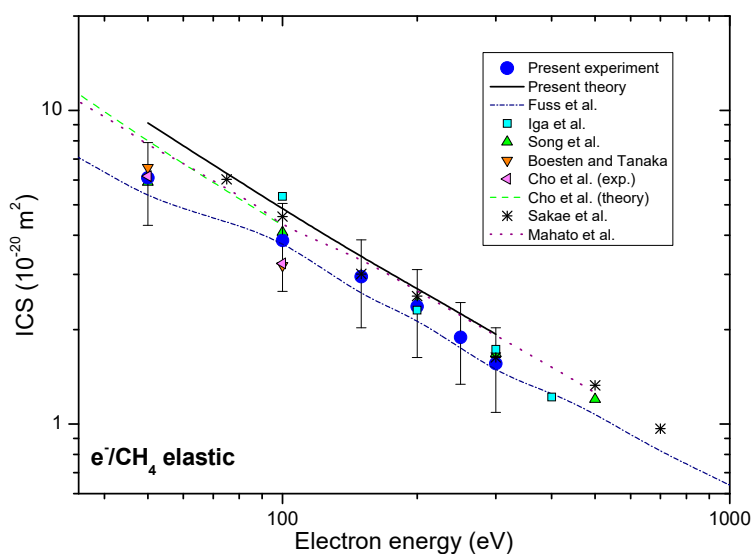

Figure 2. Integral cross-sections for elastic electron-methane collision, presented in energy range from 35 eV to 1000 eV. Present experimental (blue circles) and theoretical (solid black line) results are shown together with previous experimental, as well as the theoretical results, for comparison.

5. Discussion

Experimental DCS at 50 eV exhibits wide minimum at 100° scattering angle, for which position and depth are in good agreement with other authors' results [17,25,29,32,33], especially experimental ones [17,25,29]. Our calculations overestimate the measured DCS, but it matches with shape and is in a good agreement with other theories [29,32] at high scattering angles, above 110°. It is interesting to note that all existing experimental values at 50 eV impact energy agree among themselves within the estimated uncertainties. It is rather a problem with theories, which, in most cases, overestimate absolute values or do so at certain angular ranges.

There are many experimental and theoretical data for DCS at 100 eV. This cross-section shows a wide and shallow local minimum at 80° scattering angle, which vanishes for incident electron energies above 150 eV. Its position is the same or similar for every shown result. Our measurement and calculation are in strong agreement with the experimental result of Iga et al. [31] and with the theories of Jain (SEP) [32] and Mahato et al. [33], except at higher scattering angles (from 105°). Other results are in good agreement with the shape, but quantitatively are underestimated in comparison with the present result. It seems that there are two classes of experimental values that differ in absolute values, one by Boesten and Tanaka [25] and Cho et al. [29] and the other by Iga et al. [31] and the present measurements. One of the significant differences between these two sets of data lie in the choice of the reference gas, the former used He while the later used Ne and Ar as a reference. Nevertheless the cross-sections for He are known with better accuracy than those of Ne and Ar, it seems plausible to conclude that more similar flow conditions between the reference gas and the target one give more reliable data. If it has been possible to obtain perfectly the same all conditions necessary for applying the relative flow method, then the choice of reference gas would be the one with the best-known cross-sections, i.e., He gas. However, since the method itself introduces additional uncertainties, in our opinion, it would be the best procedure to compare cross-sections with relatively similar flows within gas inlet system.

As for DCSs for 150 eV, there are only results by Fuss et al. [34] available for comparison. At this energy, there are no local minima, like for 50 eV and 100 eV. Instead, there is a wide plateau from 70° scattering angle. Experiment and theory are in good agreement by the shape, but the experiment is, on average, about 30% quantitatively lower.

DCSs for 200 eV (both measured and calculated) show good agreement (within experimental uncertainty) with experimental results of Iga et al. [31], recommended data by Song et al. [17] and theoretical results by Jain (SEP) [32] and Mahato et al. [33] for smaller scattering angles (below 70°). Results by Vušković and Trajmar [26] are good by shape but higher in absolute value.

For DCS for 250 eV incident electron energy, to the best of our knowledge, there are no published experimental or theoretical results. In the graph, it can be seen that our theory is slightly higher than the measured results, but both are similar qualitatively.

At 300 eV, the shapes and values of present theory and previous results by Iga et al. [31] and Song et al. [17] are in almost perfect agreement. The experimental result is just slightly lower on the absolute scale. Same as for every other energy, calculations by Jain [32] and Mahato et al. [33] agree good for smaller scattering angles, but for higher, they little overestimate other results.

The values of DCSs span over three and four orders of magnitude in presented energy range, what is the characteristic behavior for molecular targets and noticed also in the previous targets [42,48]. The general agreement among different experimental datasets and calculations is very good, and that is what one may expect at the present level of advanced experiments and sophisticated calculations [49].

The present experimental integral cross-sections ICSs are shown in Table 1 and together with other available results in Figure 2. Our experimental ICSs are placed between recommended Fuss et al. [34] and theoretical results Mahato et al. [33]. In the electron energy range from 50 eV to 300 eV most of the other experimental ICSs, like those by

Boesten and Tanaka [25], Sakae et al. [30], Iga et al. [31], Song et al. [17], lie within the same uncertainty limits. Our experimental DCS data are obtained in rather limited angular range, and that is why the presented integral cross-sections depend strongly upon the extrapolation procedure. We have normalized our calculated DCS (model 2) to our measured absolute data to best match in shape and then used these values for integration. These values are presented in Table 2 with the uncertainty of 30% that arises from different plausible extrapolations. The absolute uncertainties of ICS and MTCS values are obtained from the difference of the corridor that is represented by maximal, $DCS + \Delta/2$, and minimal $DCS - \Delta/2$ values.

If total cross-section (TCS) we calculate as the sum of our measured ICSs, and ionization cross-sections obtained by Djurić et al. [50] plus the recommended neutral dissociation cross-sections by Fuss et al. [34], the TCS values obtained in such way agree well, within experimental uncertainties, with previously published experimental values by Zecca et al. [51] and recommended values by Song et al. [17]. Furthermore, for electron energies greater than 150 eV present TCS well agree with the semiempirical TCS by García and Manero [52] extrapolated in the interval energies of this paper. Total cross-sections for electron-methane collision in the energy range from 45 eV to 300 eV are contrasted in Figure 3a, while the corresponding Fano-Bethe plot is shown in Figure 3b. For electron energies from 150 eV to 300 eV Bethe plot of present TCS, References [17,51] and extrapolated semiempirical TCS García and Manero [52], agree within the limits of experimental uncertainties. This, under the given conditions, suggests that Born-Bethe approximation is valid in the electron energy range from 150 eV to 300 eV.

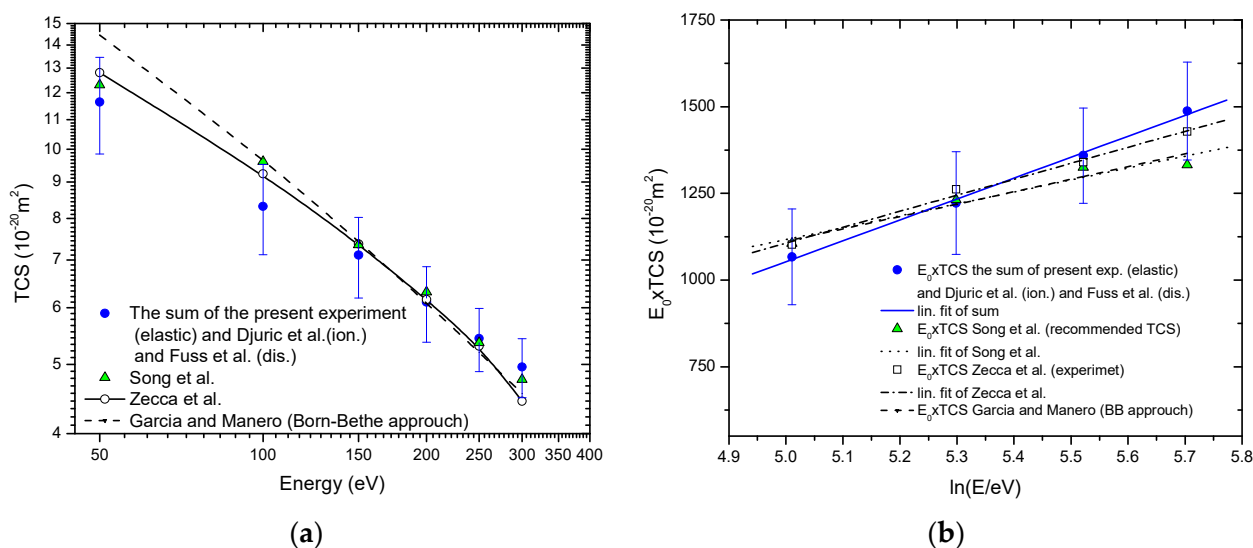

Figure 3. Total cross-sections for electron-methane collision in energy range from 45 eV to 300 eV. ●, present; ▲, Song et al. (recommended values) [17]; —○—, Zecca et al. (experiment) [51]; - - -, García and Manero (Born-Bethe approach) [52]; (a) Absolute values; (b) The Fano-Bethe plot: —, linear fit of present; ●●, linear fit of Song et al. [17]; - - - linear fit of Zecca et al. [51].

6. Conclusions

In order to provide the insight into methane/electron interaction, measurements and calculations of elastic electron scattering from methane target were performed. To summarize, calculated and measured cross-sections for elastic CH_4 -electron scattering in (50–300) eV incident electron energy range are reported and, conceivably, they will serve as a dependable standard for related investigations in the future. Good agreement between present theory and experiment and results available in the literature is noticed. Also, it is shown that molecular effects (especially absorption effects) play a crucial role on calculated cross-sections, particularly for very small scattering angles (below 20°). The experiment

was performed in two independent steps. First was measuring relative DCSs for fixed electron energy in function of scattering angle. Second was obtaining pair of absolute points for every energy, by relative flow method and Ar as reference gas. These absolute points were then used for normalization of relative DCSs. These independent results agree well, which is confirmation of the reliability of the experimental method. DCSs for the incident energy 250 eV is given without previous results known to the authors.

Nevertheless there are many studies of electron elastic scattering by methane molecule, our impression is that the present study is important to pinhole the absolute cross-sections, to confirm recommended sets of data for this process given by Song et al. [17] and to bring new results at one impact energy. Last but not the least, we stress the problem of the choice of a reference gas in the relative flow measurements and the necessity of choosing gases with similar flowing conditions. That could bring methane molecule to be a new standard for cross-sections measurements of other hydrocarbons or larger organic molecules.

Author Contributions: Conceptualization, all authors; methodology, J.B.M., B.P. and B.P.M.; software, K.T.; validation, all authors; experimental investigation, J.V. and J.B.M.; resources, B.P.M.; data curation, B.P.M.; writing—original draft preparation, J.V. and K.T.; writing—review and editing, B.P. and B.P.M.; visualization, J.V. and B.P.; supervision, B.P. and B.P.M.; project administration, B.P.M.; funding acquisition, B.P. and B.P.M. All authors have read and agreed to the published version of the manuscript.

Funding: This research was funded by the Institute of Belgrade, through the grant by the Ministry for Education, Science and Technological Development of the Republic of Serbia.

Institutional Review Board Statement: Not applicable.

Informed Consent Statement: Not applicable.

Data Availability Statement: The data presented in this study is contained within the article.

Acknowledgments: We are thankful to R. Srivastava for providing their data in tabular form.

Conflicts of Interest: The authors declare no conflict of interest.

Abbreviations

R. F.	radio frequency
PECVD	plasma-enhanced chemical vapor deposition
DCSs	differential cross-sections
ICSs	integral cross-sections
MTCSS	momentum transfer cross-sections
SCAR	screen corrected additivity rule
ELSEPA	Dirac partial-wave calculation of elastic scattering of electrons and positrons by atoms, positive ions and molecules
DCMA	double cylindrical mirror analyzer
RFM	relative flow method
TCS	total cross-section

References

1. Zhang, J.A.; Paige, D.A. Cold-trapped organic compounds at the poles of the Moon and Mercury: Implications for origins. *Geophys. Res. Lett.* **2009**, *36*, L16203. [[CrossRef](#)]
2. Oyama, V.I.; Carle, G.C.; Woeller, F.; Pollack, J.B.; Reynolds, R.T.; Craig, R.A. Pioneer Venus gas chromatography of the lower atmosphere of Venus. *J. Geophys. Res.* **1980**, *85*, 7891–7902. [[CrossRef](#)]
3. Krasnopolsky, V.A.; Maillard, J.P.; Owen, T.C. Detection of methane in the martian atmosphere: Evidence for life? *Icarus* **2004**, *172*, 537–547. [[CrossRef](#)]
4. Teylor, F.W.; Atreya, S.K.; Encrenaz, T.; Hunter, D.M.; Irwin, P.G.J.; Owen, T.C. The composition of the atmosphere of Jupiter. In *Jupiter: The Planet, Satellites and Magnetosphere*, 1st ed.; Bagenal, F., Dowling, T., McKinnon, W.B., Eds.; Cambridge Univ. Press: Cambridge, UK, 2004; pp. 59–78.
5. Fletcher, L.N.; Orton, G.S.; Teanby, N.A.; Irwin, P.G.J.; Bjoraken, G.I. Methane and its isotopologues on Saturn from Cassini/CIRS observations. *Icarus* **2009**, *199*, 351–367. [[CrossRef](#)]

6. Bezdard, B.; Romani, P.N.; Conrath, B.J.; Maguire, W.C. Hydrocarbons in Neptune's stratosphere from Voyager infrared observations. *J. Geophys. Res.* **1991**, *96*, 18961–18975. [[CrossRef](#)]
7. Karkoschka, E.; Tomasko, M.G. The haze and methane distributions on Neptune from HST-STIS spectroscopy. *Icarus* **2011**, *211*, 780–797. [[CrossRef](#)]
8. Houghton, J. Global warming. *Rep. Prog. Phys.* **2005**, *68*, 1343–1403. [[CrossRef](#)]
9. Yusuf, R.O.; Noor, Z.; Abba, A.H.; Hassan, M.A.; Din, M.F.M. Methane emission by sectors: A comprehensive review of emission sources and mitigation methods. *Renew. Sustain. Energy Rev.* **2012**, *16*, 5059–5070. [[CrossRef](#)]
10. Dlugokencky, E.J.; Hall, B.D.; Montzka, S.A.; Dutton, G.; Muähle, J.; Elkins, J.W. Long-lived greenhouse gases. *Bull. Am. Meteor. Soc.* **2019**, *100*, S48–S50.
11. Sharma, R.; Woehrl, N.; Vrućinić, M.; Timpner, M.; Buck, V.; Barhai, P.K. Effect of microwave power and C₂ emission intensity on structural and surface properties of nanocrystalline diamond films. *Thin Solid Films* **2011**, *519*, 7632–7637. [[CrossRef](#)]
12. Fraga, M.; Rodrigo Pessoa, R. Progresses in Synthesis and Application of SiC Films: From CVD to ALD and from MEMS to NEMS. *Micromachines* **2020**, *11*, 799. [[CrossRef](#)] [[PubMed](#)]
13. Horton, L.D. Atomic and molecular data needs for fusion research. *Phys. Scr.* **1996**, *T65*, 175–178. [[CrossRef](#)]
14. Blanco, F.; Ellis-Gibbins, L.; García, G. Screening corrections for the interference contributions to the electron and positron scattering cross sections from polyatomic molecules. *Chem. Phys. Lett.* **2016**, *645*, 71–75. [[CrossRef](#)]
15. Allan, M. Improved techniques of measuring accurate electron-molecule cross sections near threshold and over a large angular range. *AIP Conf. Proc.* **2007**, *901*, 107–116. [[CrossRef](#)]
16. Marinković, B.P.; Srečković, V.A.; Vujčić, V.; Ivanović, S.; Uskoković, N.; Nešić, M.; Ignjatović, L.M.; Jevremović, D.; Dimitrijević, M.S.; Mason, N.J. BEAMDB and MOLD–Databases at the Serbian Virtual Observatory for collisional and radiative processes. *Atoms* **2019**, *7*, 11. [[CrossRef](#)]
17. Song, M.Y.; Yoon, J.S.; Cho, H.; Itikawa, Y.; Karwasz, G.P.; Kokoouline, V.; Nakamura, Y.; Tennyson, J. Cross Sections for Electron Collisions with Methane. *J. Phys. Chem. Ref. Data* **2015**, *44*, 023101. [[CrossRef](#)]
18. Bettega, M.H.F.; do Varella, M.T.N.; Lima, M.A. Polarization effects in the elastic scattering of low-energy electrons by XH₄ X=(C, Si, Ge, Sn, Pb). *Phys. Rev. A* **2003**, *68*, 012706. [[CrossRef](#)]
19. Bundschu, C.T.; Gibson, J.C.; Gulley, R.J.; Brunger, M.J.; Buckman, S.J.; Sanna, N.; Gianturco, F.A. Low-energy electron scattering from methane. *J. Phys. B* **1997**, *30*, 2239–2259. [[CrossRef](#)]
20. Shyn, T.W.; Cravens, T.E. Angular distribution of electrons elastically scattered from CH₄. *J. Phys. B* **1990**, *23*, 293–300. [[CrossRef](#)]
21. Sohn, W.; Kocher, K.-H.; Scheuerlein, K.-M.; Jung, K.; Ehrhardt, H. Elastic electron scattering from CH₄ for collision energies between 0.2 and 5 eV. *J. Phys. B* **1986**, *19*, 3625–3632. [[CrossRef](#)]
22. Varambhia, H.N.; Munro, J.J.; Tennyson, J. R-matrix calculations of low-energy electron alkane collisions. *Int. J. Mass Spectrom.* **2008**, *271*, 1–7. [[CrossRef](#)]
23. Tennyson, J. Electron–molecule collision calculations using the R-matrix method. *Phys. Rep.* **2010**, *491*, 29–76. [[CrossRef](#)]
24. Brigg, W.J.; Tennyson, J.; Plummer, M. R-matrix calculations of low-energy electron collisions with methane. *J. Phys. B* **2014**, *47*, 185203. [[CrossRef](#)]
25. Boesten, L.; Tanaka, H. Elastic DCS for e+CH₄ collisions, 1.5–100 eV. *J. Phys. B* **1991**, *24*, 821–832. [[CrossRef](#)]
26. Vušković, L.; Trajmar, S. Electron impact excitation of methane. *J. Chem. Phys.* **1983**, *78*, 4947–4951. [[CrossRef](#)]
27. Tanaka, H.; Okada, T.; Boesten, L.; Suzuki, T.; Yamamoto, T.; Kubo, M. Differential cross sections for elastic scattering of electrons by CH₄ in the energy range of 3 to 20 eV. *J. Phys. B* **1982**, *15*, 3305–3319. [[CrossRef](#)]
28. Dhal, S.S.; Srivastava, B.B.; Shingal, R. Elastic scattering of electrons by methane molecules at intermediate energies. *J. Phys. B* **1979**, *12*, 2727–2734. [[CrossRef](#)]
29. Cho, H.; Park, Y.S.; Castro, E.A.Y.; de Souza, G.L.C.; Iga, I.; Machado, L.E.; Bressansin, L.M.; Lee, M.-T. A comparative experimental–theoretical study on elastic electron scattering by methane. *J. Phys. B* **2008**, *41*, 045203. [[CrossRef](#)]
30. Sakae, T.; Sumiyoshi, S.; Murakami, E.; Matsumoto, Y.; Ishibashi, K.; Katase, A. Scattering of electrons by CH₄, CF₄ and SF₆ in the 75–700 eV range. *J. Phys. B* **1989**, *22*, 1385–1394. [[CrossRef](#)]
31. Iga, I.; Lee, M.-T.; Homem, M.G.P.; Machado, L.E.; Bressansin, L.M. Elastic cross sections for e⁻-CH₄ collisions at intermediate energies. *Phys. Rev. A* **2000**, *61*, 022708. [[CrossRef](#)]
32. Jain, A. Total (elastic + absorption) cross sections for e-CH₄ collisions in a spherical model at 0.10–500 eV. *Phys. Rev. A* **1986**, *34*, 3707–3722. [[CrossRef](#)]
33. Mahato, D.; Sharma, L.; Stauffer, A.D.; Srivastava, R. Electron impact elastic scattering from methane and silane molecules. *Eur. Phys. J. D* **2019**, *73*, 189. [[CrossRef](#)]
34. Fuss, M.C.; Muñoz, A.; Oller, J.C.; Blanco, F.; Hubin-Franskin, M.-J.; Almeida, D.; Limão-Vieira, P.; García, G. Electron–methane interaction model for the energy range 0.1–10,000 eV. *Chem. Phys. Lett.* **2010**, *486*, 110–115. [[CrossRef](#)]
35. Furness, J.B.; McCarthy, I.E. Semiphenomenological optical model for electron scattering on atoms. *J. Phys. B* **1973**, *6*, 2280–2291. [[CrossRef](#)]
36. Salvat, F. Optical-model potential for electron and positron elastic scattering by atoms. *Phys. Rev. A* **2003**, *68*, 012708. [[CrossRef](#)]
37. Lide, D.R. *CRC Handbook of Chemistry and Physics*, 79th ed.; CRC Press: Boca Raton, FL, USA, 1998.
38. Perdew, J.P.; Zunger, A. Self interaction correction to density functional approximations for many electron systems. *Phys. Rev. B* **1981**, *23*, 5048–5079. [[CrossRef](#)]

39. Mott, N.F. The scattering of fast electrons by atomic nuclei. *Proc. R. Soc. Lond. Ser. A* **1929**, *124*, 425–442. [[CrossRef](#)]
40. Salvat, F.; Jablonski, A.; Powell, C.J. ELSEPA Dirac partial-wave calculation of elastic scattering of electrons and positrons by atoms, positive ions and molecules. *Comput. Phys. Commun.* **2005**, *165*, 157–190. [[CrossRef](#)]
41. Lucas, B.C. *Atomic and Molecular Beams Production and Collimation*; CRC Press: Boca Raton, FL, USA, 2012; pp. 217–223.
42. Ranković, M.; Maljković, J.B.; Tökési, K.; Marinković, B.P. Elastic electron differential cross sections for argon atom in the intermediate energy range from 40 eV to 300 eV. *Eur. Phys. J. D* **2018**, *72*, 30. [[CrossRef](#)]
43. Williams, J.F.; Willis, B.A. The scattering of electrons from inert gases I. Absolute differential elastic cross sections for argon atoms. *J. Phys. B* **1975**, *8*, 1670–1682. [[CrossRef](#)]
44. Maljković, J.B.; Blanco, F.; García, G.; Marinković, B.P.; Milosavljević, A.R. Absolute cross sections for elastic electron scattering from methylformamide. *Phys. Rev. A* **2012**, *85*, 042723. [[CrossRef](#)]
45. Olander, D.R.; Kruger, V. Molecular Beam Sources Fabricated from Multichannel Arrays. III. The Exit Density Problem. *J. Appl. Phys.* **1970**, *41*, 2769–2776. [[CrossRef](#)]
46. Tanaka, H.; Ishikawa, T.; Masai, T.; Sagara, T.; Boesten, L.; Takekawa, M.; Itikawa, Y.; Kimura, M. Elastic collisions of low- to intermediate-energy electrons from carbon dioxide: Experimental and theoretical differential cross sections. *Phys. Rev. A* **1998**, *57*, 1798–1808. [[CrossRef](#)]
47. Buckman, S.J.; Gulley, R.J.; Moghbelalhossein, M.; Bennett, S.J. Spatial profiles of effusive molecular beams and their dependence on gas species. *Meas. Sci. Technol.* **1993**, *4*, 1143–1153. [[CrossRef](#)]
48. Maljković, J.B.; Vuković, J.; Tökési, K.; Predojević, B.; Marinković, B.P. Elastic electron scattering cross sections for triethyl phosphate molecule at intermediate electron energies from 50 to 250 eV. *Eur. Phys. J. D* **2019**, *73*, 27. [[CrossRef](#)]
49. Bartschat, K.; Tennyson, J.; Zatsarinny, O. Quantum-Mechanical Calculations of Cross Sections for Electron Collisions with Atoms and Molecules. *Plasma Process. Polym.* **2017**, *14*, 1600093. [[CrossRef](#)]
50. Djurić, N.; Cadež, I.; Kurepa, M. Electron impact total ionization cross-sections for methane, ethane and propane. *Int. J. Mass Spectrom. Ion Process.* **1991**, *108*, R1–R10. [[CrossRef](#)]
51. Zecca, A.; Karwasz, G.; Brusa, R.S.; Szmytkowski, C. Absolute total cross sections for electron scattering on CH₄ molecules in the 1–4000 eV energy range. *J. Phys. B* **1991**, *24*, 2747–2754. [[CrossRef](#)]
52. García, G.; Manero, F. Electron scattering by CH₄ molecules at intermediate energies (400–5000 eV). *Phys. Rev. A* **1998**, *57*, 1069–1073. [[CrossRef](#)]



Article

Absolute Differential Cross-Sections for Elastic Electron Scattering from Sevoflurane Molecule in the Energy Range from 50–300 eV

Jelena Vukalović^{1,2}, Jelena B. Maljković¹, Francisco Blanco³, Gustavo García^{4,5}, Branko Predojević² 
and Bratislav P. Marinković^{1,*} 

¹ Institute of Physics Belgrade, University of Belgrade, Pregrevica 118, 11080 Belgrade, Serbia; jelena.vukovic@pmf.unibl.org (J.V.); jelenam@ipb.ac.rs (J.B.M.)

² Faculty of Science, University of Banja Luka, Mladena Stojanovića 2, 78000 Banja Luka, Republic of Srpska, Bosnia and Herzegovina; bpredojevic@teol.net

³ Departamento de Estructura de la Materia Física Térmica y Electrónica e IPARCOS, Universidad Complutense de Madrid, Plaza de Ciencias 1, 28040 Madrid, Spain; pacobr@fis.ucm.es

⁴ Instituto de Física Fundamental, Consejo Superior de Investigaciones Científicas, Serrano 113-bis, 28006 Madrid, Spain; g.garcia@csic.es

⁵ Centre for Medical Radiation Physics, University of Wollongong, Wollongong, NSW 2522, Australia

* Correspondence: bratislav.marinkovic@ipb.ac.rs; Tel.: +381-11-316-0882

Abstract: We report the results of the measurements and calculations of the absolute differential elastic electron scattering cross-sections (DCSs) from sevoflurane molecule ($C_4H_3F_7O$). The experimental absolute DCSs for elastic electron scattering were obtained for the incident electron energies from 50 eV to 300 eV, and for scattering angles from 25° to 125° using a crossed electron/target beams setup and the relative flow technique for calibration to the absolute scale. For the calculations, we have used the IAM-SCAR+I method (independent atom model (IAM) applying the screened additivity rule (SCAR) with interference terms included (I)). The molecular cross-sections were obtained from the atomic data by using the SCAR procedure, incorporating interference term corrections, by summing all the relevant atomic amplitudes, including the phase coefficients. In this approach, we obtain the molecular differential scattering cross-section (DCS), which, integrated over the scattered electron angular range, gives the integral scattering cross-section (ICS). Calculated cross-sections agree very well with experimental results, in the whole energy and angular range.

Keywords: sevoflurane; cross-section; elastic scattering; electrons



Citation: Vukalović, J.; Maljković, J.B.; Blanco, F.; García, G.; Predojević, B.; Marinković, B.P. Absolute Differential Cross-Sections for Elastic Electron Scattering from Sevoflurane Molecule in the Energy Range from 50–300 eV. *Int. J. Mol. Sci.* **2022**, *2*, 10021. <https://doi.org/10.3390/ijms23010021>

Academic Editor:
Krzysztof Bobrowski

Received: 27 November 2021

Accepted: 15 December 2021

Published: 21 December 2021

Publisher's Note: MDPI stays neutral with regard to jurisdictional claims in published maps and institutional affiliations.



Copyright: © 2021 by the authors. Licensee MDPI, Basel, Switzerland. This article is an open access article distributed under the terms and conditions of the Creative Commons Attribution (CC BY) license (<https://creativecommons.org/licenses/by/4.0/>).

1. Introduction

Sevoflurane (SF) is sweet-smelling non-flammable highly fluorinated methyl isopropyl ether with a boiling point at a temperature of 58.5°C . Molar mass is 200.055 g/mol , vapor pressure 197 mmHg at 26°C , and dipole moment 2.33 D [1]. It is one of the most commonly used inhalational anaesthetics, and it has been widely investigated. The recent review on inhaled anaesthetics [2] covered their environmental role, occupational risk, and clinical use. Gaya da Costa and co-authors [2] extensively elaborated on the case of sevoflurane molecule and its contribution to the global warming effect as a volatile anaesthetic (especially in combination with the use with N_2O), pointed out that its threshold has not yet been established in the workplace as waste anaesthetic gas, considering its side effects in a clinical context (epileptiform electroencephalogram patterns in both adults and paediatric populations; the cardio protective effect in patients with coronary artery disease undergoing vascular surgery, kidney transplantation or lung surgery). The atmospheric lifetimes of the halogenated anaesthetics, halothane, enflurane, sevoflurane, isoflurane, and desflurane to the reaction to the hydroxyl radical (OH) and UV photolysis have been determined from observations of OH reaction kinetics and UV absorption spectra [3]. Halothane, enflurane, and isoflurane showed distinct UV absorption in the range $200\text{--}350\text{ nm}$, and no absorption in

the wavelength range 200–350 nm was detected for sevoflurane. Tang et al. [1] analysed the effects of general anaesthetics on their potential targets by large-scale molecular simulation. The structural parameters and partial atomic charges of the anaesthetics, considered to be of great importance, were determined. Geometric optimizations using the Hartree–Fock and the B3LYP (Becke, 3-parameter, Lee–Yang–Parr) density functional theory methods with the large 6–311+G (2d,p) basis set were performed to determine the structures and charge distributions of two halogenated anaesthetics; sevoflurane and halothane. Lesarri and co-authors [4] investigated the conformational landscape of the volatile anaesthetic sevoflurane. The structure of the anaesthetic haloether sevoflurane ($\text{CH}_2\text{F}-\text{O}-\text{CH}(\text{CF}_3)_2$) has been resolved using Fourier-transform microwave (FT-MW) spectroscopy in a supersonic-jet expansion. In isolated conditions, sevoflurane adopts a single conformation characterized by a gauche fluoromethoxy group and a near-symmetric orientation of the isopropyl group with respect to the ether plane (cis H–C_{ipr}–O–CF). A schematic drawing of sevoflurane is shown in Figure 1.

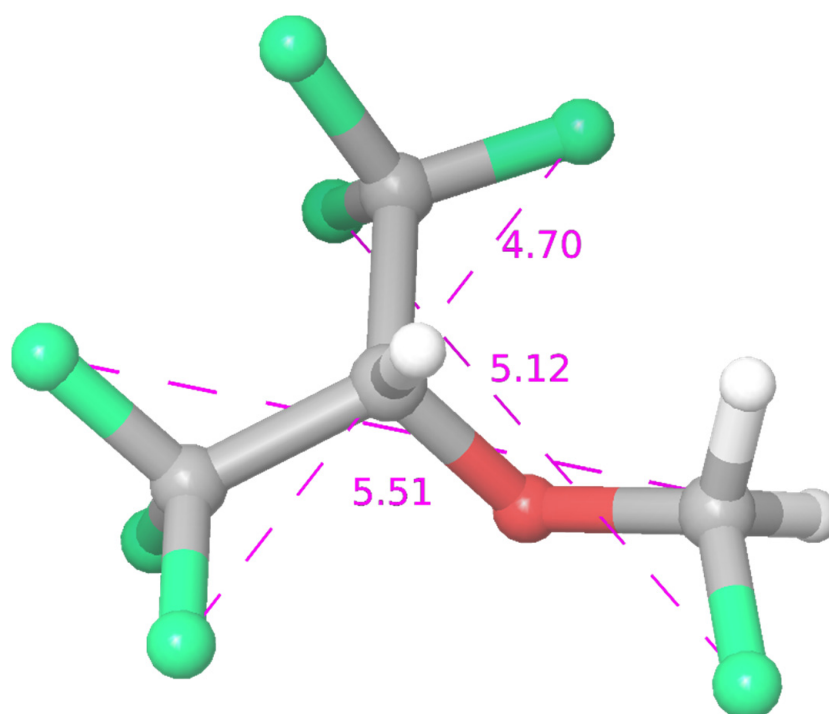

Figure 1. Schematic drawing of sevoflurane.

Don et al. [5] proposed a vibrational assignment of sevoflurane and studied its interaction with the aromatic model compound benzene, using the vibrational spectroscopy of supersonic jet expansions and of cryo solutions in liquid xenon. Sevoflurane has been investigated from the medical point of view also. Shiraishi and Ikeda [6] studied an uptake and biotransformation of sevoflurane in humans and concluded that, despite its relatively large minimum alveolar concentration (MAC), sevoflurane has a small uptake due to its low solubility, but the degradation rate is shown to be high, resulting in a higher serum fluoride concentration than for other halogenated anaesthetics. Most recently, Dong et al. [7] assessed mice and neurons treated with anaesthetics sevoflurane and desflurane, and applied nanobeam-sensor technology, an ultrasensitive method, to measure tau/p-tau amounts. They showed that the sevoflurane induces tau trafficking from neurons to microglia.

Lange et al. [8] have investigated the lowest-lying electronic states of isoflurane and sevoflurane in the 5.0–10.8 eV energy range by experimental and theoretical methods. Photoabsorption spectra of isoflurane and sevoflurane have been measured with synchrotron radiation over the photon range 5.0–10.8 eV. Low-lying excited singlet valence and Rydberg states are investigated, and the assignments supported by quantum chemical calculations,

the latter also helping to identify the triplet states. The measured absolute cross-sections have been used to calculate the photolysis lifetimes of isoflurane and sevoflurane in the Earth's atmosphere.

Electron collisions with sevoflurane have also been investigated. Very recently, Lozano et al. [9] reported total scattering cross-section from sevoflurane of 1–300 eV electrons. The experimental results, obtained from an implemented magnetic beam apparatus, are compared with theoretical results from the independent atom model, with a screening corrected additivity rule including interference effects and rotational excitation.

As pointed out by Tanaka et al. [10], the absolute electron-impact excitation cross-sections could be obtained by normalization to elastic scattering cross-section (which is the subject of the present study), or in other ways to determine the binary encounter (BE) scaling curve, after measuring the DCSs at high-energy impact (>100 eV), and for small scattering angles. A comprehensive review of experimental techniques and calculation methods for determination of electron cross-sections from biomolecules, biofuels and their fragments, has been recently given by Brunger [11], covering extensive literature in the field.

In this paper, theoretical and experimental results for elastic electron scattering from sevoflurane, in the medium energy range, are shown, complementing the investigations of electron interaction with this molecule. According to our knowledge, these are the first reported results for absolute differential cross-sections in the energy range from 50–300 eV.

Experimentally obtained data include absolute differential cross-sections for elastic electron scattering for the incident electron energy range from 50 to 300 eV (with 50 eV steps) and an angular range from 25° to 125° (with 5° steps), and integral and momentum transfer cross-sections for every measured energy. The experiment was performed on a crossed-beam apparatus. Relative points were put on the absolute scale with the help of the relative flow method, using Ar as a reference gas. Theoretical results are obtained using the IAM-SCAR+I method (independent atom model (IAM) applying the screened additivity rule (SCAR) with interferences terms included (I)). A very good level of agreement has been found between the present experimental and theoretical data, within the experimental uncertainties.

The paper is organized as follows. The experimental setup and measurement procedure are given in Section 2. The theory and calculations of DCSs are explained in Section 3. Obtained results are shown graphically and in the table, and discussion is shown in Section 4. Section 5 is reserved for the conclusion.

2. Experiment

A schematic drawing of the experimental set-up is shown in Figure 2. Our beam profile has been determined in a previous set of measurements [12–14]. In our experiment, the source of molecular beam is a stainless steel gas needle, with a diameter of $d = 0.5$ mm and a tube length of $l = 40$ mm, which gives the ratio $\Gamma = d/l = 80$, while the input pressures were such that the free mean path (λ) was larger than the inner diameter of the tube. According to Lucas [15], the proposed conditions for Γ and λ are $\Gamma > 10$ and $\lambda \approx d$, so we fulfil all the requirements for the well-collimated beam, and the derived expressions can be used in our experiment. Moreover, author [15] states that the beam properties will be optimized if the ratio of the square of single tube length and its diameter is maximized, which, in our case, is 3200.

The analysing system consists of a front four-electrode lens, energy analyser, and rear three-electrode lens. The four-electrode lens is used for collecting, directing, and focusing scattered electrons to the energy analyser after slowing them down to the constant analyser pass energy. Electron energy analyser is a double cylindrical mirror analyser (DCMA), which, essentially, represents two cylindrical analysers connected in series. Pass energy is determined by the potential difference between the cylinders. The three-electrode lens is used for focusing analysed electrons into the detector (single channel electron multiplier).

Since detecting particles are electrons, detector entrance is grounded, and exit is on a high positive potential.

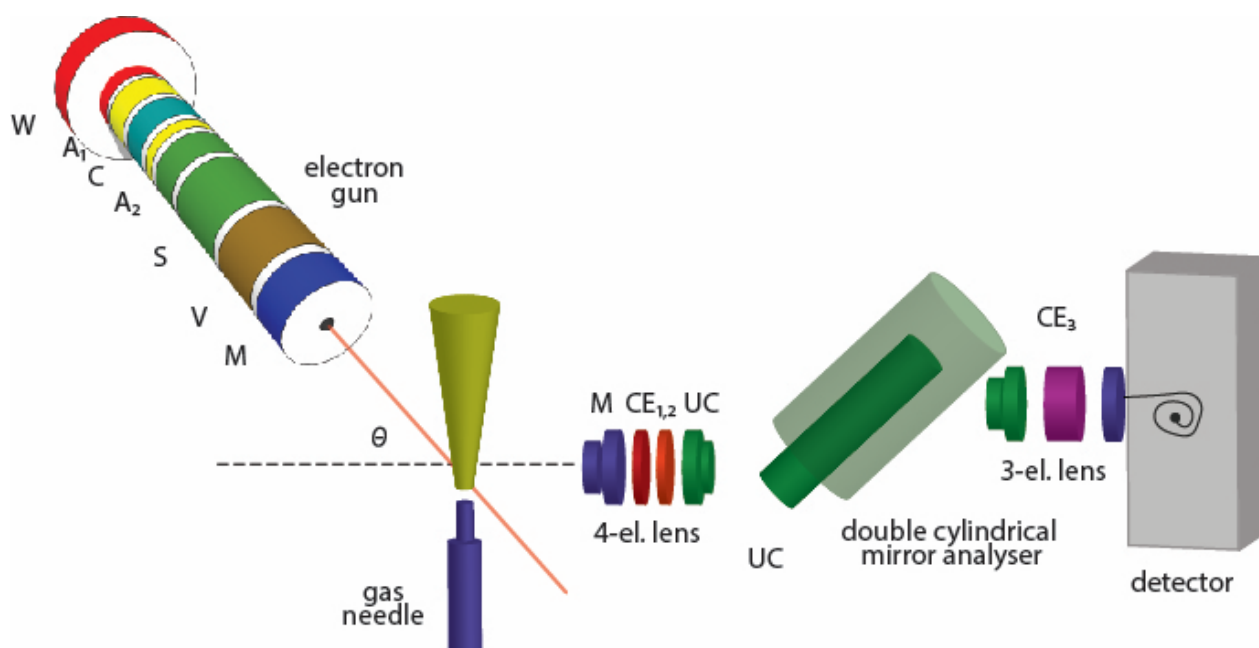

Figure 2. Schematic drawing of the experimental set-up.

The anhydrous sevoflurane ($C_4H_3F_7O$) used in this experiment had a declared purity better than 99%. Before starting the measurements a few freeze-thaw-pump cycles under vacuum have been made. Sevoflurane (SF) is a liquid at room temperature and was introduced into the scattering region from a glass container via a gas line system. SF molecule is characterized by vapor pressure (197 mm Hg at 26 °C) and relatively high dipole moment (2.33 D). Therefore, to provide stable experimental conditions, everything was heated to approximately 50 °C during the gas phase measurements in analogy with previously studied molecular targets [16,17]. In the present work, pipes and the needle were also heated providing a stable driving pressure behind the needle and also for avoiding the absorption effects [18].

In order to reduce magnetic disturbance, the experimental setup is placed in the chamber shielded by the two concentric μ -metal layers. The pre-experimental pressure in the chamber was about 5×10^{-7} mbar and the working pressure was an order of magnitude higher.

The experimental procedure for acquiring the absolute differential cross-sections for elastic scattering of electrons from sevoflurane molecule consists of two main stages:

- Stage 1: obtaining relative DCSs by measuring the intensity of electrons elastically scattered from SF, in the function of scattering angle (from 25° to 125° in 5° steps), for a given incident electron energy (50, 100, 150, 200, 250 and 300 eV). Electron intensities are measured at least three times for every incident energy. Background contributions are suppressed by introducing gas into the chamber, away from the interaction volume, via a side leak, and by subtracting measured intensities from the apparent signal for every angle at the given energy;
- Stage 2: Obtaining absolute points (two) for every electron energy, and normalizing relative DCSs on them. Absolute points are obtained using the relative flow method [19,20].

In the present work, DCSs for elastic electron scattering from sevoflurane have been measured at selected incident electron energies, from 50 to 300 eV (in 50 eV steps), and at scattering angles from 20° to 125° (in 5° steps). At given electron energy, the relative cross-section has been derived as a function of scattering angle by measuring the elastic

scattering intensity at the maximum of the elastic peak. The background contributions of the elastic electron intensities, which were around 10% at higher energies, were subtracted from the measured electron yields. It should be noted that the background contributions were generally more important at low incident energies and scattering angles (around 15%). During the measurements, potentials on electron gun electrodes and DCMA were adjusted to keep interaction volume constant. Deviations that can occur at small angles are corrected by comparing cross-sections from Ar at given energy with other authors' data [14,21].

Measured relative DCSs were normalized to the absolute scale according to the absolute points (at 40°, 80°, 90° or 100°), obtained by a Relative flow method (RFM) previously explained in detail [22]. In RFM we compare intensities of elastically scattered electrons on the target molecule (SF) and referent gas (we used Ar), under the same experimental conditions [19,20]. In order to obtain the same experimental conditions, the same beam profiles, for both target molecule and referent gas must be provided. According to Olander and Kruger [23], the same beam profiles can be obtained with two conditions: (1) the mean free paths for both gases must be the same and (2) the mean free path is approximately equal to the diameter of stainless steel gas needle. $\lambda \approx d$. In the experiment, the first condition is achieved by adjusting pressures behind the gas needle inversely proportional to the ratio of the squared gas kinetic diameters, and for second condition gas pressures need to be low, which is fulfilled in our experiment [14]. Gas kinetic diameter for Ar is 3.58 Å and for sevoflurane 5.51 Å, so the pressure ratio was $P_{Ar} : P_{SF} = D_{SF}^2 : D_{Ar}^2 \sim 2.4$. When the same beam profiles for both, target molecule (DCS_x) and referent gas (DCS_{ref}) are obtained, according to Nickel et al [19,20], absolute differential cross-sections for target molecule $DCS_x(E, \theta)$ can be calculated, knowing absolute differential cross-sections for the referent gas $DCS_{ref}(E, \theta)$, at the same energy and angle, using a formula:

$$DCS_x(E, \theta) = DCS_{ref}(E, \theta) \frac{N_x F_{ref}}{N_{ref} F_x} \sqrt{\frac{M_{ref}}{M_x}} \quad (1)$$

Quantities that we measure in the experiment are: Flow rate (F) and intensity of elastically scattered electrons (N). M_{ref} and M_x are molecular masses for referent gas and target molecule, respectively. The relative flow rate has been determined by closing an outlet to the chamber, admitting target gases into a closed constant volume, and then measuring the pressure increase in time. The flow is determined from the experimental curve of pressure versus time fitted by the least-squares method. The whole system was heated to minimize absorption effects [18], which can influence measuring flow rates and determining the flow.

Our experimental spectrometer UGRA is limited in performing angular dependent differential cross-sections measurements (25–125°) and to obtain integral (ICs) and momentum transfer cross-sections (MTCSs) we need to extrapolate measured DCSs to 0° and 180°. For extrapolation, from 0–25°, and 125–180° we used calculated results obtained by IAM + SCAR + I procedure (see section Theory) and appropriate integration. Our experimental DCS data are obtained in a rather limited angular range and that is why the presented integral cross-sections depend strongly upon the extrapolation procedure. The exact formulae used for the integration are in the form:

$$ICS = 2\pi \int_0^\pi DCS(\theta) \sin \theta d\theta \quad (2)$$

$$MTCS = 2\pi \int_0^\pi DCS(\theta)(1 - \cos \theta) \sin \theta d\theta \quad (3)$$

The uncertainties of the relative DCSs consist of statistical uncertainties and short-term stability uncertainties, caused by the instability of the system. This uncertainty is increased by 20% for small scattering angles, due to the potential alteration of the interaction volume. Dominant uncertainty for absolute DCSs are those from reference cross-sections for Ar [14,21], and are taken to be about 20%. The total uncertainties, derived as the square

root of the sum of squares of individual independent uncertainties, for absolute DCSs are about 30% for small angles and about 22% for the rest of the angular range. The total uncertainties of ICSs and MTCs arise from the DCSs uncertainties mentioned above and uncertainties of the extrapolation of DCSs to 0° and 180° and numerical integration and were approximately 30%.

3. Theory

To calculate the differential elastic, integral elastic, and inelastic as well as the total cross-sections we have used the IAM-SCAR+I method (independent atom model (IAM) applying the screened additivity rule (SCAR) with interferences terms included (I)). This method has been described in detail in previous publications [9,24–28]. Briefly, the molecular target is described as an aggregate of its individual atoms (i.e., C, H, F, and O in this case). Each atomic target is represented by an ab initio interacting complex optical potential given by:

$$V_{opt}(\vec{r}) = V_R(\vec{r}) + iV_{abs}(\vec{r}) \quad (4)$$

In Equation (4), the real part accounts for elastic scattering while the imaginary part represents the inelastic processes which are considered as the ‘absorption part’ following the procedure of Staszewska et al. [29]. The real part is divided into three terms that include:

$$V_R(\vec{r}) = V_s(\vec{r}) + V_{ex}(\vec{r}) + V_{pol}(\vec{r}), \quad (5)$$

where v_s represents a static term derived from a Hartree-Fock calculation of the atomic charge distribution [30], V_{ex} an exchange term to account for the indistinguishability of the incident and target electrons [31], and V_{pol} a long-range polarization term [32].

The molecular cross-sections are obtained from the atomic data by using the screening corrected additivity rule (SCAR) procedure [33], incorporating interference (I) term corrections [25], by summing all the relevant atomic amplitudes, including the phase coefficients. In this approach, we obtain the molecular differential scattering cross-section (DCS), which integrated over all the scattered electron angular range gives the integral scattering cross-section (ICS). Moreover, by taking the sum of the ICS for all open channels (elastic ICS and inelastic ICS) the total cross-section (TCS) could be obtained. Note that we do not include at this stage any contribution from vibrational and rotational excitation processes.

Sevoflurane is a polar molecule with a permanent dipole moment of 2.22 D [1] and therefore rotational excitations, not accounted for by the above procedure, are relevant within the scattering scheme. In order to approximately include differential and integral rotational excitation cross-section in the present study, we used the first-Born approximation, following the procedure described in [27]. In these conditions, these cross-sections can easily be calculated by considering the molecule as a rigid rotor, with the initial rotational excited state distribution in equilibrium at 300 K, and calculating all the transitions $\Delta J = \pm 1$ (J being the rotational quantum number) assuming the Born approximation but including the correction for the larger angles given by Dickinson (see ref. [34] and references therein).

4. Results

Experimental results for DCSs, together with experimental ICSs and MTCs, for elastic electron scattering from sevoflurane, are presented in Table 1, all with corresponding absolute uncertainties. Experimentally measured and theoretically calculated DCSs are shown graphically in Figure 3. The experiment covers six energies of impact electrons, from 50 eV to 300 eV, and the angular range from 25° to 125° (theory covers all angles, from 0° to 180°). Absolute uncertainties are about 22%, except for small angles, where uncertainties are increased to about 30% due to the potential interaction volume alterations.

Table 1. Experimental results for absolute differential cross-sections (DCSs), integral cross-sections (ICSs) and momentum transfer cross-sections (MTCSs) for elastic electron scattering from sevoflurane. In parentheses are given absolute uncertainties of the last two digits.

θ (°)	DCS ($10^{-20} \text{ m}^2 \text{ sr}^{-1}$)					
	50 (eV)	100 (eV)	150 (eV)	200 (eV)	250 (eV)	300 (eV)
25	3.6(1.1)	2.55(76)	1.50(39)	2.25(74)	1.82(56)	1.53(45)
30	3.07(93)	1.98(59)	1.25(32)	1.44(48)	1.20(37)	1.12(33)
35	2.17(66)	1.64(49)	0.82(21)	1.01(33)	0.99(30)	0.96(28)
40	1.89(43)	1.14(34)	0.69(14)	0.80(26)	0.84(26)	0.72(21)
45	1.77(40)	0.78(23)	0.55(11)	0.71(24)	0.67(16)	0.43(13)
50	1.57(36)	0.61(14)	0.476(94)	0.61(16)	0.43(10)	0.304(66)
55	1.31(30)	0.49(11)	0.386(77)	0.41(11)	0.282(67)	0.235(51)
60	1.01(23)	0.428(98)	0.289(57)	0.270(71)	0.223(53)	0.202(44)
65	0.82(18)	0.369(84)	0.211(42)	0.214(57)	0.220(52)	0.180(39)
70	0.68(15)	0.307(70)	0.155(31)	0.194(51)	0.189(45)	0.160(35)
75	0.55(13)	0.243(56)	0.126(25)	0.195(51)	0.162(38)	0.141(31)
80	0.47(11)	0.203(47)	0.117(23)	0.179(47)	0.150(36)	0.122(27)
85	0.380(86)	0.165(38)	0.127(25)	0.165(44)	0.139(33)	0.107(24)
90	0.339(77)	0.157(36)	0.125(25)	0.160(43)	0.127(30)	0.095(21)
95	0.327(74)	0.154(35)	0.129(26)	0.162(44)	0.117(28)	0.096(21)
100	0.347(79)	0.175(40)	0.128(25)	0.167(44)	0.109(26)	0.091(20)
105	0.396(90)	0.188(43)	0.130(26)	0.160(42)	0.111(27)	0.090(21)
110	0.48(11)	0.225(51)	0.146(29)	0.160(42)	0.118(28)	0.093(20)
115	0.59(13)	0.265(61)	0.161(32)	0.165(44)	0.113(27)	0.089(20)
120	0.71(16)	0.311(71)	0.179(35)	0.173(46)	0.116(28)	0.088(20)
125	0.85(19)	0.367(84)	0.193(38)	0.170(45)	0.122(29)	0.085(19)
ICS's	37(10)	26.9(8.3)	20.5(5.6)	18.8(6.4)	16.6(5.2)	15.3(4.6)
MTCS's	13.5(4.3)	5.8(1.5)	2.94(68)	2.90(85)	2.14(58)	1.66(43)

DCSs have characteristic behavior for molecular targets, noticed previously [12,13]. At 50 eV and 100 eV DCSs exhibit a wide minimum at 100° scattering angle, which disappears at higher incident electron energies. Experiment and theory are generally in good agreement, both in shape and on the absolute scale. There are systematic discrepancies at small angles for all electron energies, probably because of the instability of interaction volume at those angles during the experiment. Also, there are obvious declinations of DCSs for 150 eV electron energies at high scattering angles.

Concerning the normalization procedure of our results, in the relative flow measurements, absolute DCSs for Ar are taken from Ranković et al. [14] for incident electron energies 50–200 eV and 300 eV and from Williams and Willis [22] for electron energy of 250 eV. In both papers, the absolute values were derived by measurements of angular dependences of elastically scattered electrons using electron spectrometers, two 127° cylindrical electrostatic energy analysers in [21], and a double cylindrical mirror analyser (DCMA) in [14]. Authors had different normalization procedures. Ranković et al. [14] used He as a reference gas and Williams and Willis [21] a phaseshift analysis of the relative angular distributions of electrons elastically scattered in the energy region of the resonances $^2P_{3/2,1/2}$ of Ar. Both absolute differential cross-sections agree within mutual uncertainties as discussed in [10]. Since our normalization is based upon RFM, we prefer to use values from the most recent paper [14] because they were obtained at the same electron spectrometer UGRA and only for the energy of 250 eV, which is not available from our apparatus [14], we used those from Williams and Willis [21].

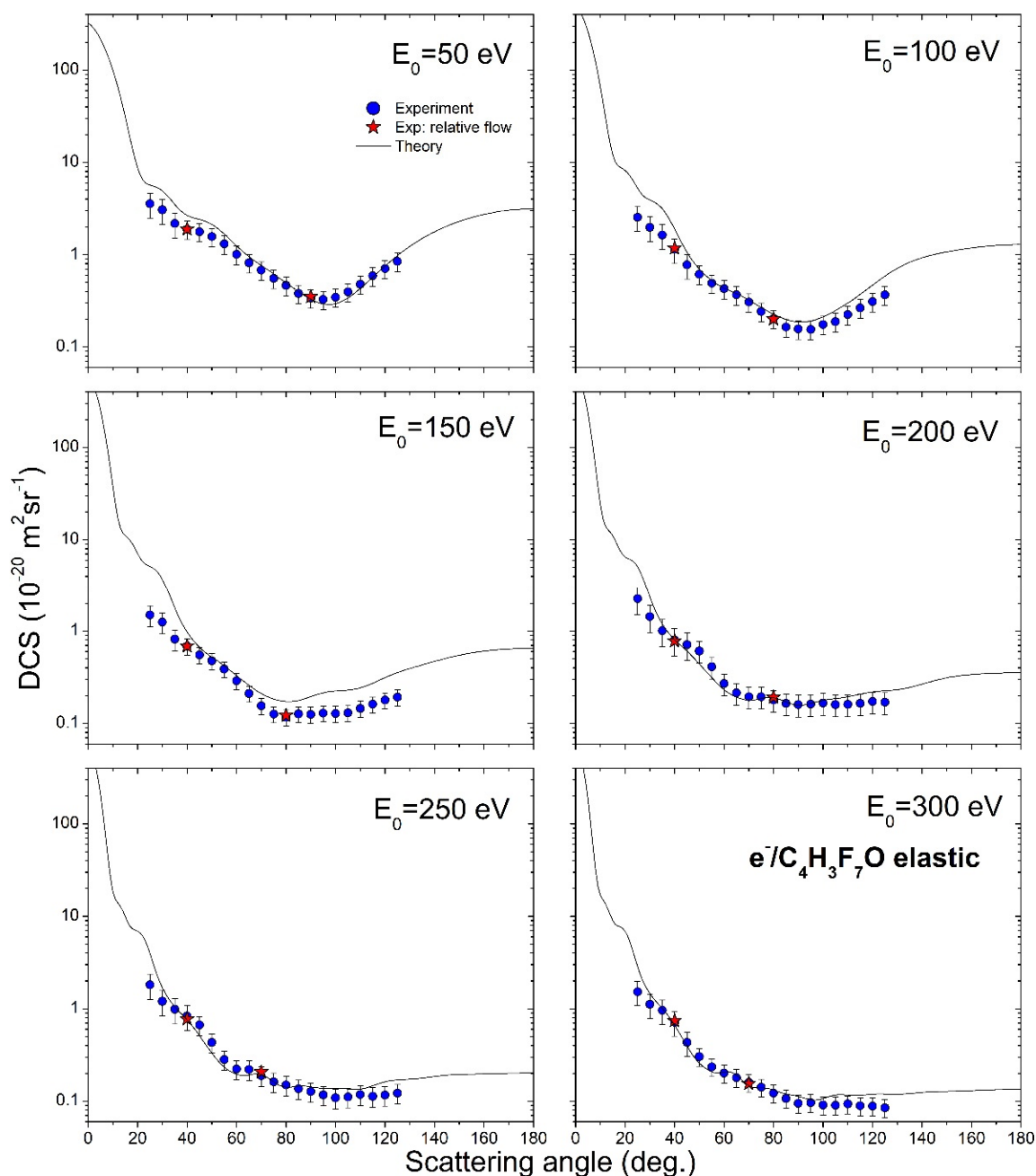

Figure 3. Angularly dependent differential cross-sections for elastic electron scattering from sevoflurane molecule, for six incident electron energies, from 50 eV to 300 eV. The present results include: experiment (blue circles), relative flow absolute data (red stars) and theory (full line).

The shapes of the experimental and theoretical cross-section plots are in excellent agreement, but measured points are 25% lower than the calculated ones. Because our experiment is angularly limited, ICS depends on the used extrapolation method, which consisted of the normalization of our theoretical DCSs to our measured absolute ones. We have normalized calculated DCS to the measured absolute data to best match in shape and then used these values for integration. These values are presented in Table 1 with an uncertainty of 30% that arises from different plausible extrapolations. The absolute uncertainties of ICS and MTCS values are obtained from the difference of the corridor that is represented by maximal, $DCS + \Delta/2$, and minimal $DCS - \Delta/2$ values.

Measured and calculated absolute differential and integral cross-sections are graphically presented in Figures 3 and 4, and to the best of the authors knowledge, there are no other published results, neither experimental nor theoretical, for DCS or ICSs for elastic electron scattering from sevoflurane in this energy and angular range.

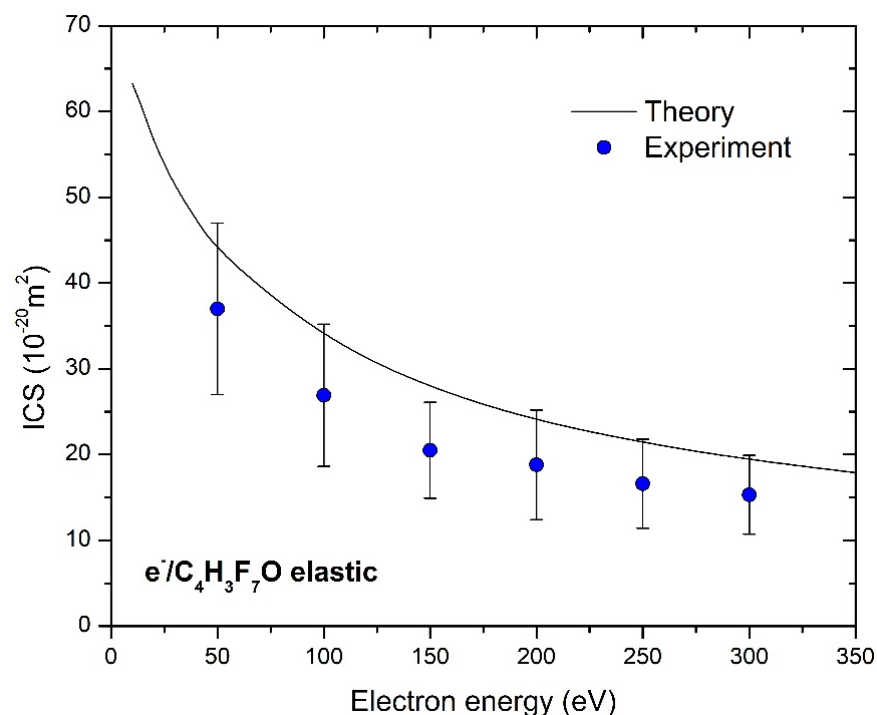

Figure 4. Integral cross-section for elastic electron collision with sevoflurane molecule in the energy range from 10 eV to 350 eV. Experiment (blue circles) and theory (solid black line) are presented.

5. Conclusions

We performed the experimental and theoretical investigation of elastic electron collisions on sevoflurane molecule at intermediate incident electron energies in order to provide insight into electron/sevoflurane interaction. Two independent sets of measurements, relative differential cross-sections at fixed energy in the function of scattering angle and absolute differential cross-sections obtained by relative flow method were performed. The last one provides us with two absolute points for every incident energy, which were used for the normalization to the absolute scale. These two independent sets of measurements showed good agreement which gives reliability to our experimental procedure. We have shown good agreement between the present experiment and theory (IAM-SCAR+I method) on the absolute scale and also in the shape. Using Ar we stress the problem of the choice of the reference gas in the relative flow measurements, since conditions should be provided for the widths (shapes) of the target beam and the reference gas beam to be approximately the same, which is easier to achieve with Ar in relation to He or Ne, since they are much lighter. The importance of this investigation is that according to our knowledge these are the first reported results for absolute differential and integral cross-sections for elastic electron scattering on sevoflurane in the energy range from (50–300) eV.

Author Contributions: Conceptualization, all authors; methodology, J.B.M. and B.P.M.; software, F.B. and G.G.; validation, all authors; experimental investigation, J.V. and J.B.M.; resources, B.P.M.; data curation, B.P.M.; writing—original draft preparation, J.V., J.B.M. and G.G.; writing—review and editing, B.P.M. and J.V.; visualization, J.V. and B.P.; supervision, B.P.M.; project administration, B.P.M.; funding acquisition, B.P.M. All authors have read and agreed to the published version of the manuscript.

Funding: This research was funded by the Institute of Physics Belgrade, through the grant by the Ministry for Education, Science and Technological Development of the Republic of Serbia. This study is partially supported by the Spanish Ministerio de Ciencia e Innovación (Project PID2019-104727RB-C21) and CSIC (Project LINKA20085).

Institutional Review Board Statement: Not applicable.

Informed Consent Statement: Not applicable.

Data Availability Statement: The data presented in this study is contained within the article. All data are possible to retrieve from the Belgrade Electron Atom/Molecule DataBase (BEAMDB) at <http://servo.aob.rs/emol> after the article has been published.

Acknowledgments: This article/publication is based upon work from COST Action CA18212—Molecular Dynamics in the GAS phase (MD-GAS), supported by COST (European Cooperation in Science and Technology).

Conflicts of Interest: The authors declare no conflict of interest.

References

1. Tang, P.; Zubrycki, I.; Xu, Y. Ab Initio Calculation of structures and properties of halogenated general anesthetics: Halothane and sevoflurane. *J. Comput. Chem.* **2001**, *22*, 436–444. [[CrossRef](#)]
2. Gaya da Costa, M.; Kalmar, A.F.; Struys, M.M.R.F. Inhaled Anesthetics: Environmental Role, Occupational Risk, and Clinical Use. *J. Clin. Med.* **2021**, *10*, 1306. [[CrossRef](#)] [[PubMed](#)]
3. Langbein, T.; Sonntag, H.; Trapp, D.; Hoffmann, A.; Malms, W.; Röth, E.P.; Mörs, V.; Zellner, R. Volatile anaesthetics and the atmosphere: Atmospheric lifetimes and atmospheric effects of halothane, enflurane, isoflurane, desflurane and sevoflurane. *Br. J. Anaesth.* **1999**, *82*, 66–73. [[CrossRef](#)] [[PubMed](#)]
4. Lesarri, A.; Vega-Toribio, A.; Suenram, R.D.; Brughe, D.J.; Grabowd, J.U. The conformational landscape of the volatile anesthetic sevoflurane. *Phys. Chem. Chem. Phys.* **2010**, *33*, 9624–9631. [[CrossRef](#)]
5. Dom, J.; Van der Veken, B.; Michielsens, B.; Jacobs, S.; Xue, Z.; Hesse, S.; Loritz, H.-M.; Suhmb, M.A.; Herrebout, W.A. On the weakly C–H··· π hydrogen bonded complexes of sevoflurane and benzene. *Phys. Chem. Chem. Phys.* **2011**, *13*, 14142–14152. [[CrossRef](#)]
6. Shiraishi, Y.; Ikeda, K. Uptake and biotransformation of sevoflurane in humans: A comparative study with halothane, enflurane, and isoflurane. *J. Clin. Anesth.* **1990**, *2*, 381–386. [[CrossRef](#)]
7. Dong, Y.; Liang, F.; Huang, L.; Fang, F.; Yang, G.; Tanzi, R.E.; Zhang, Y.; Quan, Q.; Xie, Z. The anesthetic sevoflurane induces tau trafficking from neurons to microglia. *Commun. Biol.* **2021**, *4*, 560. [[CrossRef](#)]
8. Lange, E.; Ferreira da Silva, F.; Jones, N.C.; Hoffmann, S.V.; Duflot, D.; Limão-Vieira, P.M. The lowest-lying electronic states of isoflurane and sevoflurane in the 5.0–10.8 eV energy range investigated by experimental and theoretical methods. *Chem. Phys. Lett.* **2019**, *716*, 42–48. [[CrossRef](#)]
9. Lozano, A.I.; Ferreira da Silva, F.; Blanco, F.; Limão-Vieira, P.M.; García, G. Total electron scattering cross section from sevoflurane by 1–300 eV energy electron impact. *Chem. Phys. Lett.* **2018**, *706*, 533–537. [[CrossRef](#)]
10. Tanaka, H.; Brunger, M.J.; Campbell, L.; Kato, K.; Hoshino, M.; Rau, A.R.P. Scaled plane-wave Born cross sections for atoms and molecules. *Rev. Mod. Phys.* **2016**, *88*, 025004. [[CrossRef](#)]
11. Brunger, M.J. Electron scattering and transport in biofuels, biomolecules and biomass fragments. *Int. Rev. Phys. Chem.* **2017**, *36*, 333–376. [[CrossRef](#)]
12. Vukalović, J.; Maljković, J.B.; Tökési, K.; Predojević, B.; Marinković, B.P. Elastic Electron Scattering from Methane Molecule in the Energy Range from 50–300 eV. *Int. J. Mol. Sci.* **2021**, *22*, 647. [[CrossRef](#)] [[PubMed](#)]
13. Maljković, J.B.; Vuković, J.; Tökési, K.; Predojević, B.; Marinković, B.P. Elastic electron scattering cross sections for triethyl phosphate molecule at intermediate electron energies from 50 to 250 eV. *Eur. Phys. J. D* **2019**, *73*, 27. [[CrossRef](#)]
14. Ranković, M.; Maljković, J.B.; Tökési, K.; Marinković, B.P. Elastic electron differential cross sections for argon atom in the intermediate energy range from 40 eV to 300 eV. *Eur. Phys. J. D* **2018**, *72*, 30. [[CrossRef](#)]
15. Lucas, B.C. *Atomic and Molecular Beams Production and Collimation*; CRC Press: Boca Raton, FL, USA, 2012; pp. 217–223.
16. Milosavljević, A.R.; Giuliani, A.; Šević, D.; Hubin-Franskin, M.J.; Marinković, B.P. Elastic scattering of electrons from tetrahydrofuran molecule. *Eur. Phys. J. D* **2005**, *35*, 411–416.
17. Allan, M. Absolute angle-differential elastic and vibrational excitation cross sections for electron collisions with tetrahydrofuran. *J. Phys. B* **2007**, *40*, 3531–3544. [[CrossRef](#)]
18. Homem, M.G.P.; Iga, I.; Sugohara, R.T.; Sanches, I.P.; Lee, M. Role of adsorption effects on absolute electron-molecule cross-section calibration using the relative flow technique. *Rev. Sci. Instrum.* **2011**, *82*, 013109. [[CrossRef](#)]
19. Nickel, J.C.; Mott, C.; Kanik, I.; McCollum, D.C. Absolute elastic differential electron scattering cross sections for carbon monoxide and molecular nitrogen in the intermediate energy region. *J. Phys. B* **1988**, *21*, 1867–1877. [[CrossRef](#)]

20. Nickel, J.C.; Zetner, P.V.; Shen, G.; Trajmar, S. Principles and procedures for determining absolute differential electron-molecule (atom) scattering cross sections. *J. Phys. E* **1989**, *22*, 730–738. [[CrossRef](#)]
21. Williams, J.F.; Willis, B.A. The scattering of electrons from inert gases I. Absolute differential elastic cross sections for argon atoms. *J. Phys. B* **1975**, *8*, 1670–1682. [[CrossRef](#)]
22. Maljković, J.B.; Blanco, F.; García, G.; Marinković, B.P.; Milosavljević, A.R. Absolute cross sections for elastic electron scattering from methylformamide. *Phys. Rev. A* **2012**, *85*, 042723. [[CrossRef](#)]
23. Olander, D.R.; Kruger, V. Molecular Beam Sources Fabricated from Multichannel Arrays. III. The Exit Density Problem. *J. Appl. Phys.* **1970**, *41*, 2769–2776. [[CrossRef](#)]
24. Blanco, F.; Rosado, J.; Illana, A.; García, G. Comparison of two screening corrections to the additivity rule for the calculation of electron scattering from polyatomic molecules. *Phys. Lett. A* **2010**, *374*, 4420–4424. [[CrossRef](#)]
25. Blanco, F.; Ellis-Gibblings, L.; García, G. Screening corrections for the interference contributions to the electron and positron scattering cross sections from polyatomic molecules. *Chem. Phys. Lett.* **2016**, *645*, 71–75. [[CrossRef](#)]
26. Traore Dubuis, A.; Verkhovtsev, A.; Ellis-Gibblings, L.; Krupa, K.; Blanco, F.; Jones, D.B.; Brunger, M.J.; García, G. Total cross section of furfural by electron impact: Experiment and theory. *J. Chem. Phys.* **2017**, *147*, 054301. [[CrossRef](#)]
27. Fuss, M.C.; Sanz, A.G.; Blanco, F.; Oller, J.C.; Limão-Vieira, P.; Brunger, M.J.; García, G. Total electron-scattering cross sections from pyrimidine as measured using a magnetically confined experimental system. *Phys. Rev. A* **2013**, *88*, 042702. [[CrossRef](#)]
28. Lozano, A.I.; Oller, J.C.; Jones, D.B.; da Costa, R.F.; do, N.; Varella, M.T.; Bettega, M.H.F.; Ferreira da Silva, F.; Limão-Vieira, P.; Lima, M.A.P.; et al. Total electron scattering cross sections from para-benzoquinone in the energy range 1–200 eV. *Phys. Chem. Chem. Phys.* **2018**, *20*, 22368–22378. [[CrossRef](#)] [[PubMed](#)]
29. Staszewska, G.; Schwenke, D.W.; Thirumalai, D.; Truhlar, D.G. Quasifree-scattering model for the imaginary part of the optical potential for electron scattering. *Phys. Rev. A* **1983**, *28*, 2740–2751. [[CrossRef](#)]
30. Cowan, R.D. *The Theory of Atomic Structure and Spectra*; University of California Press: Berkeley, CA, USA, 1981.
31. Riley, M.E.; Truhlar, D.G. Approximations for the exchange potential in electron scattering. *J. Chem. Phys.* **1975**, *63*, 2182–2191. [[CrossRef](#)]
32. Zhang, X.; Sun, J.; Liu, Y. A new approach to the correlation polarization potential-low-energy electron elastic scattering by He atoms. *J. Phys. B At. Mol. Opt. Phys.* **1992**, *25*, 1893–1897. [[CrossRef](#)]
33. Blanco, F.; García, G. Screening corrections for calculation of electron scattering differential cross sections from polyatomic molecules. *Phys. Lett. A* **2004**, *330*, 230–237. [[CrossRef](#)]
34. Sanz, A.G.; Fuss, M.C.; Blanco, F.; Sebastianelli, F.; Gianturco, F.A.; García, G. Electron scattering cross sections from HCN over a broad energy range (0.1–10000 eV): Influence of the permanent dipole moment on the scattering process. *J. Chem. Phys.* **2012**, *137*, 124103. [[CrossRef](#)] [[PubMed](#)]

Subject Invitation for topical lecture at CEPAS conference
From CEPAS Organising committee <cepas@neon.dpp.fmph.uniba.sk>
To <jelenam@ipb.ac.rs>
Date 2013-11-17 20:39



Dear Dear Jelena,

I write you as chairman of the Local Organising Committee of the Conference on Elementary Processes in Atomic Systems - CEPAS. CEPAS is triennial conference and the 6th continuation will be held in Bratislava from 9th to 12th July 2014.

The main topics of the conference are:

- photo-processes and laser collisions
- electron(positron)/atom collisions
- collisions with biomolecules
- heavy particles (ion/atom) collisions
- interactions with surfaces
- processes with nano-sized complex systems

You have been selected by the members of the International Scientific Committee of the CEPAS conference as topical speaker on the topic:

Absolute differential cross sections for elastic scattering

In the program of the conference are planned 6 invited and 24 topical lectures.

It would be for me great honour if you could accept this invitation.
Please let me know your decision.

Yours sincerely,

Stefan Matejcik
Chair of the LOC

Tuesday, 8 th July 2014	
15:00 – 19:15	<i>Registration</i>
19:30 – 22:00	<i>Welcome Reception</i>
22:00	<i>2014 FIFA World Cup Brazil, 1st Semifinal Match</i>
Wednesday, 9 th July 2014	
8:00 – 8:45	<i>Registration</i>
8:45 – 9:00	<i>Opening</i>
	<i>Chairman: To be announced</i>
9:00 – 9:45	Paul Scheier University Innsbruck, AUT DECORATION OF FULLERENE IONS WITH SIMPLE MOLECULES
9:45 – 10:10	Oliver Ochedowski Universität Duisburg-Essen, DEU SWIFT HEAVY ION IRRADIATION OF GRAPHENE
10:10 – 10:40	<i>Coffee Break</i>
	<i>Chairman: To be announced</i>
10:40 – 11:25	 John Tanis Western Michigan University, USA TRANSMISSION OF ELECTRONS THROUGH MICROMETER GLASS CAPILLARIES AND DIFFERENCES WITH IONS
11:25 – 11:50	Gyula Nagy Hungarian Academy of Sciences, HUN GUIDING OF MEV ION BEAMS
12:50 – 12:15	Michael Schulz Missouri University of Science & Technology, USA MANIPULATING ATOMIC FRAGMENTATION PROCESSES BY CONTROLLING THE PROJECTILE COHERENCE
15:15 – 14:00	<i>Lunch</i>
	<i>Chairman: To be announced</i>
14:00 – 14:25	Roman Čurík Academy of Sciences of the Czech Republic, CZE INDIRECT DISSOCIATIVE RECOMBINATION OF SIMPLE IONS
14:25 – 14:50	Masamitsu Hoshino Sophia University, JPN ELASTIC SCATTERING FROM PLASMA MOLECULES AND RADICALS
14:50 – 15:15	Peter Papp Comenius University, SVK ELECTRON IONISATION AND ELECTRON ATTACHMENT OF METALORGANIC COMPOUNDS
15:15 – 15:40	Pierre-Michel Hillenbrand GSI Darmstadt, DEU MEASUREMENTS OF RADIATIVE ELECTRON CAPTURE TO THE CONTINUUM (RECC)
15:40 – 16:15	<i>Coffee Break</i>
16:15 – 19:00	Poster Session I (max. A1 portrait paper size)
19:00 – 22:00	<i>Individual Dinner in the City</i>
22:00	<i>2014 FIFA World Cup Brazil, 2nd Semifinal Match</i>

Thursday, 10 th July 2014	
	<i>Chairman: To be announced</i>
9:00 – 9:45	Dragana Marić University of Belgrade, SRB ATOMIC AND MOLECULAR PROCESSES OF INTEREST FOR MODELING OF DISCHARGES IN LIQUIDS
9:45 – 10:10	Kinga Kutasi Hungarian Academy of Sciences, HUN SURFACE AND GAS PHASE PROCESSES IN AFTERGLOW PLASMAS AIMED FOR MEDICAL STERILIZATION
10:10 – 10:40	<i>Coffee Break</i>
	<i>Chairman: To be announced</i>
10:40 – 11:25	Don Madison Missouri University of Science & Technology, USA ACCURACY OF THEORETICAL CALCULATIONS FOR ELECTRON-IMPACT IONIZATION OF MOLECULE
11:25 – 11:50	Jeff Shinpaugh East Carolina University, USA ATOMIC COLLISION PROCESSES IN BIOLOGICAL AND CHEMICAL SYSTEMS
12:50 – 12:15	Sadia Bari European XFEL GmbH, DEU DISSOCIATION OF PEPTIDES BY IONS AND PHOTONS
15:15 – 14:00	<i>Lunch</i>
	<i>Chairman: To be announced</i>
14:00 – 14:25	Oddur Ingólfsson University of Iceland, ISL METASTABLE FREGMANTATION OF BIOMOLECULES
14:25 – 14:50	Jelena Maljković University of Belgrade, SRB ABSOLUTE CROSS SECTIONS FOR ELASTIC ELECTRON SCATTERING FROM FURAN AND THF MOLECULES
14:50 – 15:15	Filipe Ferreira da Silva Universidade Nova de Lisboa, PRT ON ELECTRON INDUCED PROCESSES IN BIOMOLECULES
15:15 – 15:40	Lothar Schmidt Goethe-Universität Frankfurt am Main, DEU MOMENTUM TRANSFER TO A FREE FLOATING DOUBLE SLIT: REALIZATION OF A THOUGHT EXPERIMENT FROM THE EINSTEIN-BOHR DEBATES
15:40 – 16:15	<i>Coffee Break</i>
16:15 – 16:40	Martin Čížek Charles University in Prague, CZE LOW ENERGY REACTIVE COLLISIONS IN O ⁻ + H ₂
16:40 – 17:05	Yuri Kozhedub St. Petersburg State University, RUS ELECTRONIC DYNAMICS IN LOW-ENERGY HEAVY-ION COLLISIONS
19:00	<i>Conference Dinner – Hotel Borik</i>

Friday, 11 th July 2014	
	<i>Chairman: To be announced</i>
9:00 – 9:45	Yasuyuki Nagashima Tokyo University of Science, JPN NEW DEVELOPMENTS OF THE PS- STUDIES
9:45 – 10:10	Tom Kirchner York University, CAN INTERACTION OF ANTIPROTONS AND PROTONS WITH ATOMS: A DENSITY-FUNCTIONAL THEORY PERSPECTIVE
10:10 – 10:40	<i>Coffee Break</i>
	<i>Chairman: To be announced</i>
10:40 – 11:25	Fernando Martin Universidad Autonoma de Madrid, ESP ELECTRON AND NUCLEAR DYNAMICS IN THE PHOTOIONIZATION OF MOLECULES
11:25 – 11:50	Elisabeth Gruber Vienna University of Technology, AUT TRANSMISSION OF SLOW HIGHLY CHARGED IONS THROUGH 1 NM THICK CARBON NANOMEMBRANES
12:50 – 12:15	Zoltan Juhasz ATOMKI, HUN GUIDED TRANSMISSION OF IONS THROUGH NANOCAPILLARIES: VARIATIONS IN DISCHARGING DYNAMICS
15:15 – 14:00	<i>Lunch</i>
	<i>Chairman: To be announced</i>
14:00 – 14:25	Stefan Fritzsche Helmholtz-Institute Jena, DEU THEORETICAL DESCRIPTION OF RELATIVISTIC ATOMIC COLLISIONS
14:25 – 14:50	Alexey Verkhovtsev Goethe University, DEU PHOTOIONIZATION OF FULLERENES AND OTHER NANOCARBON SYSTEMS
14:50 – 15:15	Sandor Borbely Babes-Bolyai University SPATIAL INTERFERENCE EFFECTS DURING THE IONIZATION OF ATOMS BY FEW-CYCLE LASER PULSES
15:15 – 15:40	Florian Trinter Goethe-Universitaet Frankfurt am Main, DEU TIME DEPENDENCE OF INTERATOMIC COULOMBIC DECAY
15:40 – 16:15	<i>Coffee Break</i>
16:15 – 19:00	Poster Session II (max. A1 portrait paper size)
19:00	<i>Individual Dinner in the City</i>
Saturday, 12 th July 2014	
8:30 – 16:00	<i>Excursion to Chateau Topolčianky and European Bison Park</i>

Transport of electrons through a long metallic microcapillary: characterization of the outgoing low-energy electron beam

Aleksandar R. Milosavljević^{1,*}, Jelena B. Maljković¹, Réka J. Bereczky², Miloš Lj. Ranković¹,
Bratislav P. Marinković¹ and Károly Tőkési²

(1) Institute of Physics Belgrade, University of Belgrade, Pregrevica 118, 11080 Belgrade, Serbia
(2) Institute for Nuclear Research, Hungarian Academy of Sciences, H-4001 Debrecen, Hungary, EU

e-mail: vraz@ipb.ac.rs

The guiding of charged particles – highly charged ions – by insulating nanocapillaries has been firstly reported in 2002 [1] and has been attracting a large attention since then, partly due to potential applications in ion transport [2]. The pioneering work on electron guiding through insulating capillaries has been reported recently [3,4] and the electron guiding phenomena has been discussed in detailed nowadays [5,6]. The aim of the present research is to investigate the electron transport by metallic high-aspect ratio capillaries and their potential use for a robust, spatially well-determined, low-energy electron source, which can be efficiently applied to study electron driven molecular processes under different environmental conditions.

In this work we have investigated transmission of 150 eV incident electrons through a single stainless steel microcapillary (0.9 mm diameter and 19.5 mm length – the aspect ratio of about 22). The intensity of the outgoing electron current has been measured as a function of both the incident beam angle with respect to the capillary axis (tilt angle) and the kinetic energy of outgoing electrons. The “quasi-monochromatic” incident electron beam produces a wide distribution of outgoing electrons, spanning down to practically 0 eV. At large tilt angles (when the direct beam is suppressed due to the close collision with the inner wall of the capillary) this distribution is determined by elastic electron scattering, inelastic processes and secondary electron production. It is, however, interesting that the dependence on the tilt angle changes with the outgoing kinetic energy, and low-energy electrons may dominate at larger tilt angles.

Acknowledgement: The work was supported by the MESTD RS (Project No. 171020), by the Hungarian SRF OTKA No. NN 103279, and by the Bilateral Cooperation Program between the Hungarian and Serbian Academies.

- [1] N. Stolterfoht et al., *Phys. Rev. Lett.* **88** (2002) 133201.
- [2] T. Ikeda et al., *J. Phys. Conf. Series* **399** (2012) 012007.
- [3] A. Milosavljević et al., *Phys. Rev. A* **75** (2007) 030901.
- [4] S. Das et al., *Phys. Rev. A* **76** (2007) 042716.
- [5] A. R. Milosavljević et al., *Nucl. Instrum. Meth. B* **279** (2012) 190.
- [6] K. Schiessl et al., *Phys. Rev. Lett.* **102** (2009) 163201.

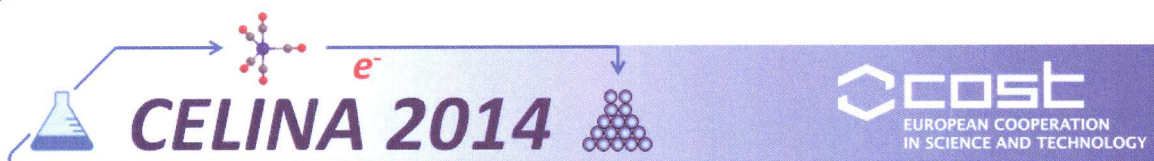

***Kick-off Meeting
COST Action CM 1301***



Chemistry for EElectron-Induced NANofabrication

March 19-22, 2014, Erlangen, Germany

Book of Abstracts

Local Organization: PD Dr. Hubertus Marbach

Scientific Organization: Prof. Dr. Petra Swiderek





26th INTERNATIONAL CONFERENCE
ON ATOMIC COLLISIONS IN SOLIDS
(ICACS-26)

13-18 July 2014
Debrecen, Hungary

PROGRAMME
AND
BOOK OF ABSTRACTS



**26th INTERNATIONAL CONFERENCE ON
ATOMIC COLLISIONS IN SOLIDS**

(ICACS-26)

13-18 July 2014

Debrecen, Hungary

PROGRAMME

AND

BOOK OF ABSTRACTS

26th INTERNATIONAL CONFERENCE ON ATOMIC COLLISIONS IN SOLIDS

13 – 18 JULY, 2014

Organized by

Gernilex Bt.

Host Institute

Institute for Nuclear Research, Hungarian Academy of Sciences



Venue

Kölcsey Convention Centre, Debrecen, Hungary

Proceedings

Papers submitted to the conference will be published by Elsevier as a special issue of *Nuclear Instruments and Methods B*

Main guest editor: Károly Tőkési

Guest editors: Réka Judit Bereczky, István Rajta, Iván Valastyán

Book of Abstracts

This book contains the camera-ready copies of the abstracts as sent by the authors. In few cases only minor corrections were made.

Editor: Attila Csík

Printed by: REXPO Kft., Manager: János Rácz

ISBN: 978-963-08-9865-2

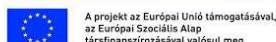

Organisers acknowledge the support of the TÁMOP-4.2.2.A-11/1/KONV-2012-0036 project implemented through the New Hungary Development Plan and co-financed by the European Social Fund.

Electron transmission through a metallic capillary

**J. B. Maljković¹, M. Lj Ranković¹, R. J. Bereczky², B. P. Marinković¹,
K. Tókési², A. R. Milosavljević¹**

¹ Laboratory for Atomic Collision Processes, Institute of Physics Belgrade, University of Belgrade, Pregrevica 118, 11080 Belgrade, Serbia

² Institute for Nuclear Research, Hungarian Academy of Sciences (ATOMKI), P. O. Box 51, H-4001 Debrecen, Hungary
jelenam@ipb.ac.rs

We present the preliminary experimental results about electron transmission through a single metallic capillary, following our previous investigation of electron guiding through insulating nanocapillaries [1]. The incident electron energy was 150 eV and the aspect ratio of the capillary was 21.67 (length $L=19.51$ mm and inner diameter $d=0.15$ mm). The kinetic energy distribution of transmitted electrons was recorded at a tilt angle (the angle between the incident electron beam and the capillary axis) of 2° . The results are obtained by an electron spectrometer, consisted of an electron gun, a double cylindrical mirror energy analyzer (DCMA) and a channeltron detector. Fig. 1 presents the kinetic energy distribution of electrons escaping the capillary. Except the dominant peak, corresponding to the direct beam and the elastic surface scattering, there is a strong fraction of electrons that suffer inelastic collisions and secondary electrons.

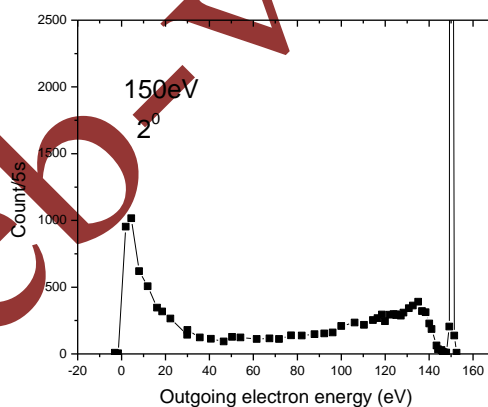

Figure 1. Energy spectrum of the electrons escaping the metallic capillary at the tilt angle 2° .

Acknowledgements: This work was supported by the Bilateral Co-operation Program between the Hungarian and Serbian Academies through project Interactions of charge particles with single insulating capillaries, by the Hungarian Research fund OTKA No. NN103279, Serbian Research Project OI 171020 and by the COST Action CM1204 (XLIC).

References

- [1] A. R. Milosavljević et al., *Phys. Rev. A* (2007) 75, 030901(R).



27th Summer School and International Symposium on the Physics of Ionized Gases

August 26-29, 2014, Belgrade, Serbia

Dr Jelena Maljković

Institute of Physics Belgrade,
University of Belgrade,
Pregrevica 118,
11080 Belgrade
Serbia

Belgrade, 21th October 2013

Dear Dr Maljković,

On behalf of the Scientific and Organizing Committees, we have a pleasure to invite you to attend the *27th Summer School and International Symposium on the Physics of Ionized Gases* (SPIG 2014) and present a **progress report** (20 min, including questions and discussions) aimed at the topics covered by the Section 1 (*Atomic Collision Processes*).

The SPIG 2014 will be held from 26th to 29th August in Belgrade, Serbia. The details of the conference are available at www.spig2014.ipb.ac.rs. Unfortunately, due to the limited conference budget, the organizers cannot commit to any financial support.

We hope that you will be able to accept our invitation. Please let us know by the 4th of November and send us the title of your lecture.

We look forward to welcoming you to Belgrade in 2014.

Yours sincerely,

Zoran Mijatović
(Chairman of the
Scientific Committee)

Dragana Marić and Aleksandar R. Milosavljević
(Co-Chairs of the Local Organizing Committee)

Local organizing Committee:

Institute of Physics, University of Belgrade
Pregrevica 118
11080 Belgrade, Serbia

Tel: +381 11 316-0882
+381 11 371-3056
Fax: +381 11 316-2190

E-mail: spig2014@ipb.ac.rs
Web: www.spig2014.ipb.ac.rs



27th Summer School and International Symposium on the Physics of Ionized Gases

August 26-29, 2014, Belgrade, Serbia

Dr Jelena Maljković

Institute of Physics Belgrade,
University of Belgrade,
Pregrevica 118,
11080 Belgrade
Serbia

Belgrade, 21th October 2013

Dear Dr Maljković,

On behalf of the Scientific and Organizing Committees, we have a pleasure to invite you to attend the *27th Summer School and International Symposium on the Physics of Ionized Gases* (SPIG 2014) and present a **progress report** (20 min, including questions and discussions) aimed at the topics covered by the Section 1 (*Atomic Collision Processes*).

The SPIG 2014 will be held from 26th to 29th August in Belgrade, Serbia. The details of the conference are available at www.spig2014.ipb.ac.rs. Unfortunately, due to the limited conference budget, the organizers cannot commit to any financial support.

We hope that you will be able to accept our invitation. Please let us know by the 4th of November and send us the title of your lecture.

We look forward to welcoming you to Belgrade in 2014.

Yours sincerely,

Zoran Mijatović
(Chairman of the
Scientific Committee)

Dragana Marić and Aleksandar R. Milosavljević
(Co-Chairs of the Local Organizing Committee)

Local organizing Committee:

Institute of Physics, University of Belgrade
Pregrevica 118
11080 Belgrade, Serbia

Tel: +381 11 316-0882
+381 11 371-3056
Fax: +381 11 316-2190

E-mail: spig2014@ipb.ac.rs
Web: www.spig2014.ipb.ac.rs

KINETIC ENERGY DISTRIBUTION OF ELECTRONS SCATTERED INSIDE A PLATINUM TUBE AT THE INCIDENT ENERGY OF 200 eV

A. R. Milosavljević^{1,*}, M. Lj. Ranković¹, J. B. Maljković¹, R. J. Bereczky²,
B. P. Marinković¹ and K. Tőkési²

¹*Institute of Physics, University of Belgrade, Pregrevica 118, Belgrade, Serbia*

²*Institute for Nuclear Research, Hungarian Academy of Sciences, H-4001 Debrecen, Hungary, EU*

Abstract. We have measured the kinetic energy distribution of electrons escaping a macroscopic platinum (Pt) tube (3.3 mm diameter and 40.8 mm length). The 200 eV incident electron beam of about 800 nA was directed into the capillary entrance at a large tilt angle of 5.5° , with respect to the capillary axis. The results show a dominant fraction of elastically scattered electrons, accompanied by inelastic losses.

1. INTRODUCTION

Insulating micro- and nano-capillaries made of different materials have been extensively used to investigate the so-called *guiding* phenomenon, which was first revealed with the pioneering work of Stolterfoht and coauthors in 2002 [1]. Briefly, the beam of charged particles, particularly highly charged ions (HCI), dynamically deposit charge on the inner capillary surface, thus providing a Coulomb field that deflects the particles and efficiently guides them towards the capillary exit. Large attention has been devoted to this phenomenon due to both an interesting physics and possible applications, such as the possibility to introduce a micro/nano HCI beam directly into a biological object [2]. The first results on electron guiding through insulating capillaries have been reported more recently [3,4], followed by a more detailed investigations [5,6]. A comprehensive review on the subject can be found in the recent paper by Lemell et al. [7].

In contrast to the HCI, the electron transmission through insulating capillaries appeared to be much more complex [5,6,7]. Particularly, electrons can be closely elastically scattered from the surface (not only deflected by deposited charge), inelastically scattered and can produce secondary electrons (which thus affect the Coulomb interaction). Moreover, it has been suggested that even metallic (conductive) capillaries could be used for the electron guiding [6].

In the present work, we investigate electron transmission through metallic macroscopic capillaries. Our aim is both to learn about fundamental properties of the electron guiding by metallic capillaries, governed by electron-surface interaction, and to investigate the potential application of metallic high-aspect ratio capillaries as a robust, spatially well-determined, low-energy electron carrier/source, which could be efficiently applied to study electron driven molecular processes under different environmental conditions. We started investigation with a large-diameter Pt tube, in order to compare the obtained results to the electron interaction with a plane Pt surface and theoretical simulations. In the present work, we have investigated transmission of 200 eV incident electrons through a single Pt macrocapillary (3.3 mm diameter and 40.8 mm length – the aspect ratio of about 12.4). The intensity of the outgoing electron current has been measured as a function of both the incident beam angle with respect to the capillary axis (tilt angle) and the kinetic energy of outgoing electrons.

2. EXPERIMENTAL SETUP

The experiment has been performed in the Laboratory for Atomic Collision Processes, at the Institute of Physics Belgrade (IPB) by using the electron spectrometer UGRA [8], which has been modified to perform the present experiment. The electron gun produces a well collimated electron beam, with a diameter and an angular divergence estimated to be approximately 1 mm and 1° at 200 eV of the incident energy, and with an energy spread of about 0.5 eV. The Pt tube has been fitted inside the entrance electron lens system (see Figure 1), in front of the electron gun, which can be rotated around the capillary entrance in the angular domain of about -15 to $+15$ degrees. The angle between the capillary axis and incident electron beam direction is denoted as the tilt angle.

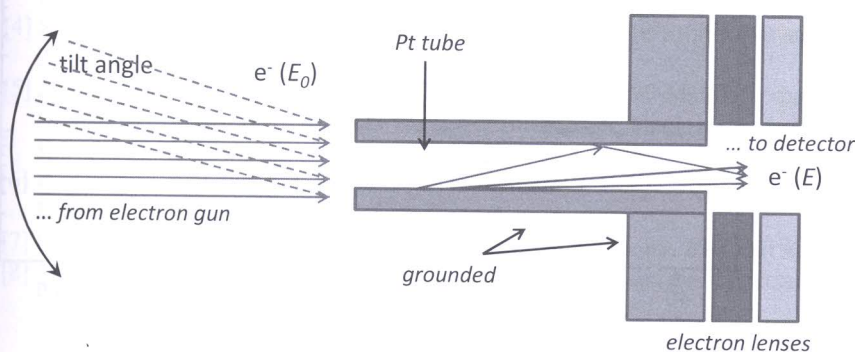

Figure 1. Schematic drawing of the experimental setup.

The electrons escaping the capillary were focused by an electrostatic lens (Figure 1) into a double cylindrical mirror energy analyzer (DCMA), followed by a single channel multiplier used as a detector. Since the entrance lens of the analyzer is fixed to have its axis parallel to the capillary axis, the observation angle is fixed at 0° and the acceptance angle also depends on the focal properties of the entrance lens. The kinetic energy distribution of the electrons escaping the capillary was measured by recording the electron current at the detector (count rates) as a function of the retarding potential at the entrance of the DCMA that worked in a constant pass-energy mode, thus providing a constant energy resolution over the whole scanned energy domain [8]. Still, it should be noted that the recorded kinetic energy distribution can be affected by the transmission of the entrance lens [8].

3. RESULTS

The preliminary obtained kinetic energy distribution of electrons escaping the Pt tube at the tilt angle of about 5.5° and for the incident electron energy of 200 eV is shown in Figure 2.

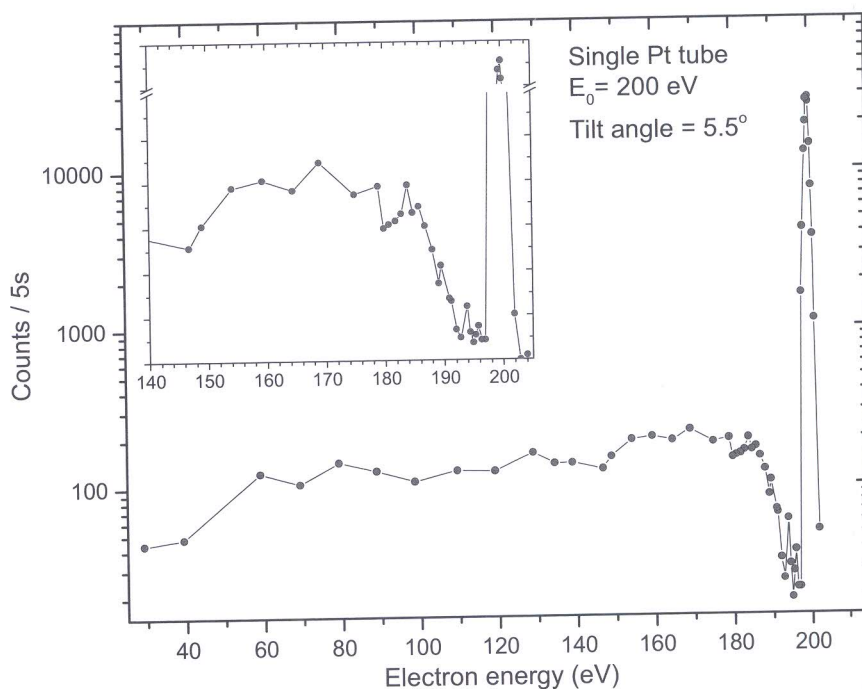

Figure 2. The kinetic energy distribution of electrons escaping the Pt tube at the tilt angle of 5.5° and the incident electron energy of 200 eV.

The aspect ratio of the Pt tube defines the tilt angle of 4.6° as a maximum angle to transmit the direct electron beam. Moreover, even at smaller tilt angles down to only a few degrees, the electron detection should not be possible due to the aspect ratio of the entrance lens stack and the DCMA (see Figure 1), which also depends on the electrostatic field. Therefore, the present results suggest that 200 eV electrons can be directed and transmitted along the metallic Pt tube. The dominant fraction of the transmitted electrons seems to suffer only elastic surface collisions. Inelastically scattered electrons are also detected and further work is in progress to compare the present results with the electron scattering from a plane Pt surface and calculations that include cylindrical geometry.

Acknowledgements

The work was supported by the Ministry of education, science and technological development of Republic of Serbia under the grant OI 171020, by the Hungarian SRF OTKA No. NN 103279, and by the Bilateral Cooperation Program between the Hungarian and Serbian Academies. The work is also motivated by ESF/COST Action CM1301 "Chemistry for Electron-Induced Nanofabrication (CELINA).

REFERENCES

- [1] N. Stolterfoht, J. - H. Bremer, V. Hoffmann, R. Hellhammer, D. Fink, A. Petrov and B. Sulik, *Phys. Rev. Lett.* 88, 133201 (2002).
- [2] T. Ikeda, T. M. Kojima, T. Kobayashi, W. Meissl, V. Mäckel, Y. Kanai and Y. Yamazaki, *J. Phys. Conf. Series* 399, 012007 (2012).
- [3] A. R. Milosavljević, Gy. Viktor, Z. D. Pešić, P. Kolarž, D. Šević, B. P. Marinković, S. Matefi-Tempfli, M. Matefi-Tempfli and L. Piraux, *Phys. Rev. A* 75, 030901 (2007).
- [4] S. Das, B. S. Dassanayake, M. Winkworth, J. L. Baran, N. Stolterfoht and J. A. Tanis, *Phys. Rev. A* 76, 042716 (2007).
- [5] A. R. Milosavljević, K. Schiessl, C. Lemell, K. Tokési, M. Mátéfi-Tempfli, S. Mátéfi-Tempfli, B. P. Marinković and J. Burgdörfer, *Nucl. Instrum. Meth. B* 279, 190 (2012).
- [6] K. Schiessl, K. Tökési, B. Solleder, C. Lemell and J. Burgdörfer, *Phys. Rev. Lett.* 102, 163201 (2009).
- [7] C. Lemell, J. Burgdörfer and F. Aumayr, *Prog. Surf. Sci.* 88, 237 (2013).
- [8] A. R. Milosavljević, S. Madžunkov, D. Šević, I. Čadež and B. P. Marinković, *J. Phys. B* 39, 609 (2006).

SPIG 2014 PROGRAM

Belgrade, Serbia, August 26 – 29, 2014

Tuesday 26 th August 2014	
Workshops	
	DEA Workshop
08:30-09:00	Registration
09:00-09:10	Opening and Introduction Nigel Mason (Open University)
	Session 1, Hall A, Chair: Nigel Mason
09:10-09:30	<i>Electron attachment to molecules studied by electron-molecular crossed beam experiment</i> Janina Kopyra , Siedlce University, Siedlce, Poland
09:30-09:50	<i>Electron attachment to unstable molecules</i> Tom Field , Queen's University of Belfast, Belfast, UK
09:50-10:10	<i>Dissociative electron attachment studies with potential radiosensitizers</i> Stephan Denifl , University of Innsbruck, Institute of Ion Physics, Innsbruck, Austria
10:10-10:30	<i>(Time-dependent) Density Functional Theory for understanding dissociative chemistry of organometallic compounds</i> Matija Zlatar , Institute of Chemistry, Technology and Metallurgy, University of Belgrade, Serbia
10:30-11:00	Coffee break
	Session 2, Hall A, Chair: Oddur Ingólfsson
11:00-11:20	<i>Dissociation of polar molecules at very low energies</i> Roman Čurík , J. Heyrovský Institute of Physical Chemistry of the ASCR, Prague, Czech Republic
11:20-11:40	<i>Role of symmetry lowering in DEA</i> Juraj Fedor , Department of Chemistry, University of Fribourg, Fribourg, Switzerland
11:40-12:00	<i>Velocity slice imaging study on dissociative electron attachment</i> Ewelina Szymanska , Department of Physical Sciences, The Open University, Milton Keynes, UK
12:00-12:20	<i>Theoretical treatment of dissociative electron attachment</i> Peter Papp , Comenius University, Bratislava, Slovakia
12:20-13:50	Lunch break (& registration)
	XiBiGP Workshop
	NonEqProc Workshop
13:50-14:00	Opening and Introduction Christophe Nicolas (SOLEIL synchrotron)
	Opening and Introduction Zoran Lj. Petrovic (SASA)
	Session 1, Hall A <i>Chair: Christophe Nicolas</i>
	Session 1, Hall B <i>Chair: Saša Dujko</i>
14:00-14:30	<i>Study of single photon multiple ionization processes with a magnetic bottle spectrometer</i> Pascal Lablanquie , LCP-MR CNRS & Université Paris VI, Paris, France
	<i>Non-equilibrium transport of charged particles in gaseous and disordered materials</i> Ron White , ARC Centre of Excellence for Antimatter-Matter Studies, James Cook University, Townsville, Australia
14:30-15:00	<i>Synchrotron radiation studies of biomolecules: photoabsorption, and core and valence photoionization</i> Kevin Prince , Sincrotrone Trieste, Trieste, Italy
	<i>First principles calculation of the effect of Coulomb collisions on electron swarms</i> Zoltan Donko , Wigner Research Centre for Physics, Hungarian Academy of Sciences, Budapest, Hungary
15:00-15:30	<i>Electron-ion coincidence spectroscopy as a tool to study radiation-induced molecular dynamics</i> Edwin Kukk , Department of Physics and Astronomy, University of Turku, Turku, Finland
	<i>Recent progress in the Newtonian three-body problem</i> Veljko Dmitrašinović and Milovan Šuvakov , Institute of Physics, Belgrade, Serbia

15:30-16:00	Coffee break and discussion	
	Session 2, Hall A <i>Chair: Lidija Andrić</i>	Session 2, Hall B <i>Chair: Marija Radmilović-Rađenović</i>
16:00-16:30	<i>Biomolecular ionization and fragmentation dynamics studied with energetic photons from synchrotrons and free electron lasers</i> Thomas Schlathöler , University of Groningen, Groningen, Netherlands	<i>Emission spectroscopy of dense plasmas in liquids: a winding road from light to chemistry</i> Thierry Belmonte , Institut Jean Lamour, Université de Lorraine, Nancy, France
16:30-17:00	<i>Action spectroscopy of stored biomolecular ions in the soft X-ray range</i> Alexandre Giuliani , Synchrotron SOLEIL, France/ Aleksandar Milosavljević , Institute of Physics, University of Belgrade, Belgrade, Serbia	<i>Picosecond-TALIF to probe atomic oxygen in the plume of an RF driven atmospheric pressure plasma jet in ambient air</i> Jérôme Bredin , The University of York, York, UK
17:00-17:30	<i>Proton transfer and non-local electronic relaxation in aqueous solutions revealed from core-level autoionization</i> Bernd Winter , BESSY, Germany	<i>Comparison of surface vacuum ultraviolet emissions with resonance level number densities in Argon and Argon containing plasmas</i> Svetlana Radovanov , Applied Materials/Varian Semiconductor, USA
17:30-18:00	Coffee break	
	Joint Session (XiBiGP & NonEqProc), Hall A <i>Chair: Bratislav Marinković</i>	
18:00-18:30	<i>Spectral analysis from physics for optimization of magnetic resonance spectroscopy in early tumor diagnostics</i> Karen Belkić , Karolinska Institute, Stockholm, Sweden	
18:30-19:00	<i>Measuring elementary plasma processes: Elastic scattering, vibrational and electronic excitation, dissociative attachment</i> Michael Allan , University of Fribourg, Switzerland	
19:00-19:30	<i>Future Studies on Electron Scattering; a Renaissance?</i> Nigel Mason , The Open University, Milton Keynes United Kingdom	
19:30-22:00	Welcome party (Gallery of Science and Technology, SASA) – concert “Ca va” (Prague)	

Wednesday 27th August 2014

SPIG 2014 (day 1)

(**PL** – Plenary lecture: 35+10 min; **TL** – Topical lecture: 25+5 min; **PR** – Progres Report: 15+5 min)

08:00-09:15	Registration	
09:15-09:45	Opening, Chair: Zoran Mijatović	
	Plenary Session 1, Hall A, Chair: Zoran Lj. Petrović	
09:45-10:30	<i>Plasma Medicine: Fundamentals and Applications</i> Alexander Fridman , Drexel University, Philadelphia, USA	
10:30-11:00	Coffee break	
	Plenary Session 2, Hall A, Chair: Luka Popović	
11:00-11:45	<i>What happens at the surface impact site of a slow highly charged ion?</i> Friedrich Aumayr , Vienna University of Technology (TU Wien), Vienna, Austria	
11:45-12:30	<i>Fifty Years of QUASARS: Physical Insights and Potential for Cosmology</i> Jack Sulentic , Instituto de Astrofísica de Andalucía – CSIC, Granada, Spain	
12:30-14:30	Lunch break	
	Parallel session A1, Chair: Aleksandar Milosavljević	Parallel session B1, Chair: Bratislav Obradović
14:30-15:00	<i>Positron interactions with atoms and molecules</i> Stephen Buckman , The Australian National University, Canberra, Australia	<i>A CCP-plasma source operation in the high-VHF to UHF frequencies and scalability to large-area applications</i> Albert R. Ellingboe , Dublin City University, Dublin, Ireland
15:00-15:30	<i>Chirality reveals electronic/nuclear motion couplings</i> Gustavo Garcia , Synchrotron SOLEIL, France	<i>Application of low temperature plasmas for restoration/conservation of archaeological objects</i> František Krčma , Brno University of Technology, Brno, Czech Republic
15:30-15:50	<i>Stability of nucleosides in the gas phase under ionizing radiation</i> Sylvain Maclot , Université de Caen Basse-Normandie, Caen, France	<i>Treatment effects and stability of metal substrates treated by cold surface DBD plasma</i> Vadym Prysiaznyi , Faculty of Engineering, UNESP, Guaratingueta, Brazil
15:50-16:30	Coffee break	
	Parallel session A2, Chair: Dragana Marić	Parallel session B2, Chair: Vladimir Srečković
16:30-17:00	<i>Liquid-phase reactions induced by atmospheric pressure glow discharge with liquid electrode</i> Fumiyoshi Tochikubo , Tokyo Metropolitan University, Tokyo, Japan	<i>Anion chemistry in Titan</i> Janko Zabka , J. Heyrovsky Institute of Physical Chemistry, Prague, Czech Republic
17:00-17:20	<i>Atmospheric Pressure Plasma Jet interactions with liquids</i> Sylwia Ptasinska , Notre Dame University, Notre Dame, USA	<i>Langmuir Waves in Interplanetary Plasma</i> Sonja Vidojević , IHIS – techno experts d.o.o, Belgrade, Serbia
17:20-17:40	<i>Low temperature plasma for medical applications</i> Ita Junkar , Jožef Stefan Institute, Ljubljana, Slovenia	<i>Studying the complex absorption profiles of Si IV in 21 HiBALQSO spectra</i> Dimitrios Stathopoulos , National and Kapodistrian University of Athens, Greece

17:40-18:00	<i>Monte Carlo modeling of positron transport in experimental devices and applications</i> Srdan Marjanović , Institute of Physics, University of Belgrade, Belgrade, Serbia	<i>Dynamic Effects in Excited Atomic Systems</i> Andrei Klyucharev , Saint-Petersburg University, St.-Petersburg, Russia
18:00-19:30	Poster session (1) - Gallery of Science and Technology, SASA <i>Posters: 1.20 – 1.33; 2.1 – 2.19; 3.1 – 3.24</i>	

Thursday 28 th August 2014		
SPIG 2014 (day 2)		
(PL – Plenary lecture: 35+10 min; TL – Topical lecture: 25+5 min; PR – Progres Report: 15+5 min)		
	Plenary Session 3, Hall A, Chair: Nikola Konjević	
09:00-09:45	<i>The role of high-energy ion-atom/molecule collisions in radiotherapy</i> Dževad Belkić , Department of Oncology and Pathology, Nobel Medical Institute, Karolinska Institute, Stockholm, Sweden	
09:45-10:30	<i>Study of a High-Performance Plasma in the Large Helical Device</i> Akio Komori , National Institute for Fusion Science, Gifu, Japan	
10:30-11:00	Coffee break	
	Plenary Session 4, Hall A, Chair: Bratislav Marinković	
11:00-11:45	<i>The two sides of the electron in FEBID: Fragmentation of molecules and molecular synthesis</i> Petra Swiderek , University of Bremen, Bremen, Germany	
11:45-12:30	<i>Recent Results for Electron Scattering from Atoms and Molecules</i> Michael Brunger , Flinders University, Adelaide, Australia	
12:30-14:30	Lunch break	
	Parallel session A3, <i>Chair: Stephen Buckman</i>	Parallel session B3, <i>Chair: Nevena Puač</i>
14:30-15:00	<i>Latest developments in low energy electron-molecule scattering: the R-matrix approach</i> Jimena Gorfinkiel , Open University, Milton Keynes, UK	<i>Deposition of innovative coatings by DBD at atmospheric-pressure</i> David Duday , CRP - Gabriel Lippmann, Belvaux, Luxembourg
15:00-15:30	<i>Low-energy electron-induced bond cleavage studied in DNA at a single-molecule level</i> Ilko Bald , Universität Potsdam, Potsdam-Golm, Germany	<i>The afterglow of a surface-wave microwave discharge as a tool for surface process studies</i> Kinga Kutasi , Hungarian academy of sciences, Budapest, Hungary
(A) 15:30-15:50 (B) 15:30-16:00	<i>Electron attachment to c-C₄F₈O: dynamics and implications for plasmas</i> Radmila Janečkova , Department of Chemistry, University of Fribourg, Fribourg, Switzerland	<i>Plasma synthesis and processing of carbon nanowalls and submicron metallic particles</i> Gheorghe Dinescu , National Institute for Laser, Plasma and Radiation Physics, Magurele, Romania
15:50-16:30	Coffee break	

	Parallel session A4, <i>Chair: Petra Swiderek</i>	Parallel session B4, <i>Chair: Saša Dujko</i>
(A) 16:30-16:50 (B) 16:30-17:00	<i>Molecular clusters: radiation induced processes and methods to control neutral beams</i> Marcin Dampc , The Open University, Milton Keynes, UK	<i>The IST-LISBON database on LXcat</i> Luís Lemos Alves , Instituto de Plasmas e Fusão Nuclear, Lisboa, Portugal
(A) 16:50-17:10 (B) 17:00-17:30	<i>Low energy electron interaction with typical focused electron beam induced deposition precursor</i> Rachel Thorman , University of Iceland, Reykjavik, Iceland	<i>Optical diagnostics of laboratory analogue of TLE discharges (Transient Luminous Events)</i> Milan Šimek , Academy of Sciences of the Czech Republic, Prague, Czech Republic
(A) 17:10-17:40 (B) 17:30-18:00	COST CELINA lecture <i>Event by event modelling procedure to simulate electron beam induced deposition</i> Gustavo Garcia , CSIC, Madrid, Spain	<i>canceled</i> Atsushi M. Ito, National Institute for Fusion Science, Gifu, Japan
17:40-18:00 (A)	COST CELINA WG1 Meeting	
18:00-19:30	Poster session (2) - Gallery of Science and Technology, SASA <i>Posters: 1.1 – 1.19, 1.34 and 1.35; 3.25 – 3.52; 4.1 – 4.9</i>	
19:30-20:00	Concert (Gallery of Science and Technology, SASA): quartet “Full Harmony”	

Friday 29th August 2014	
SPIG 2014 (day 3)	
<i>(PL – Plenary lecture: 35+10 min; TL – Topical lecture: 25+5 min; PR – Progres Report: 15+5 min)</i>	
	Plenary Session 5, Hall A, Chair: Gordana Malović
09:00-09:45	<i>Recent developments in positronium physics</i> David Cassidy , University College London, London, UK
09:45-10:30	<i>Laser ablation in liquids during nanoparticle production</i> Alessandro De Giacomo , University of Bari, Dipartimento di Chimica, Bari, Italy
10:30-11:00	Coffee break
	Plenary Session 6, Hall A, Chair: Milorad Kuraica
11:00-11:45	<i>Modelling of physical and chemical processes in cold atmospheric-pressure plasma jets</i> George Naidis , Institute for High Temperatures, RA S, Moscow, Russia
11:45-12:30	<i>Attosecond VUV Coherent Control of Molecular Dynamics and Perspectives For Using ELI-ALPS User Facility</i> Predrag Ranitović , Lawrence Berkeley National Laboratory, Berkeley, California, USA
12:30-14:30	Lunch break / SPIG Committee meeting at 13h

	Parallel session A5, <i>Chair: Goran Poparić</i>	Parallel session B5, <i>Chair: Milivoje Ivković</i>
14:30-14:50	<i>Electron transfer upon potassium collisions with biomolecules</i> Filipe Ferreira da Silva , Universidade Nova de Lisboa, Portugal	<i>Electrical breakdowns in air: new experiments and statistical and numerical models</i> Aleksandar Jovanović , University of Niš, Serbia
14:50-15:10	<i>Absolute differential cross sections for elastic electron scattering from small biomolecules</i> Jelena Maljković , Institute of Physics, University of Belgrade, Belgrade, Serbia	<i>Spectroscopic study of plasma during electrolytic oxidation of magnesium-aluminium alloys</i> Jovica Jovović , Faculty of Physics, University of Belgrade, Belgrade, Serbia
15:10-15:30	<i>Electron – Indium atom scattering and analysis of electron and optical spectra</i> Maja Rabasović , Institute of Physics, University of Belgrade, Belgrade, Serbia	<i>Measurements and models of transient and stationary regimes of glow discharge in argon</i> Marjan Stankov , University of Niš, Niš, Serbia
15:30-15:50	<i>Single electron capture in fast ion-atom collisions</i> Nenad Milojević , University of Niš, Serbia	<i>Diagnostics of Laser induced plasma by optical emission spectroscopy</i> Marko Cvejić , Institute of Physics, University of Belgrade, Belgrade, Serbia
15:50-16:30	Coffee break	
	Parallel session A6, <i>Chair: Zoltan Donkó</i>	Parallel session B6, <i>Chair: Nenad Simonović</i>
(A) 16:30-16:50 (B) 16:30-17:00	<i>Electron heating dynamics in multi-frequency capacitive RF discharges</i> Aranka Derzsi , Hungarian academy of sciences, Budapest, Hungary	<i>Electron excitation and autoionization cross sections for elements of chemically peculiar (CP) stars: Study of bismuth</i> Branko Predojević , University of Banja Luka, Banja Luka, Repubika Srpska, B&H
(A) 16:50-17:10 (B) 17:00-17:20	<i>Simulation and modeling of Resistive Plate Chambers</i> Danko Bošnjaković , Institute of Physics, University of Belgrade, Belgrade, Serbia	
(A) 17:10-17:30 (B) 17:20-17:40	<i>The non-symmetric ion-atom absorption processes in the helium rich white dwarf atmospheres in UV and EUV region</i> Vladimir Srećković , Institute of Physics, University of Belgrade, Belgrade, Serbia	<i>Wake effect in graphene due to moving charged particles</i> Ivan Radović , VINCA Institute of Nuclear Sciences, Belgrade, Serbia
	<i>Free time</i>	
20:00	Gathering and transport to Danube quay	
20:30 -	Conference dinner and Closing	

Saturday 30th August 2014

10:00-17:00	Excursions (optional, info at registration desk)
17:00	Departure



27th Summer School and
International Symposium on
the Physics of Ionized Gases

August 26-29, 2014, Belgrade, Serbia

CONTRIBUTED PAPERS &

ABSTRACTS OF INVITED LECTURES,
TOPICAL INVITED LECTURES, PROGRESS REPORTS
AND WORKSHOP LECTURES

Editors:

Dragana Marić
Aleksandar R. Milosavljević
Zoran Mijatović



Institute of Physics, Belgrade
University of Belgrade



Serbian Academy
of Sciences and Arts



Ministry of Education,
Science and Technological Development
Republic of Serbia



RocndBek
RocndBek, Ltd. 2014
RocndBek, Ltd. 2014
RocndBek, Ltd. 2014
RocndBek, Ltd. 2014



IOP Conference Series



austrijanski kulturni forum ^{bg}

INSTITUT
FRANÇAIS
SERBIE



ISBN 978-86-7762-600-6

rsn2014.ipb.ac.rs

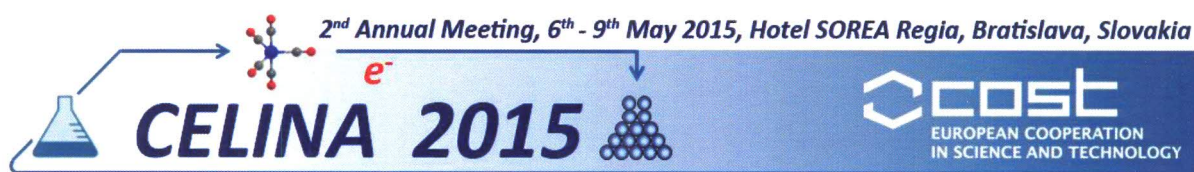

**2nd Annual Meeting of COST Action CM 1301, CELINA
Chemistry for ELection-Induced NANofabrication**

6th – 9th May, 2015, Bratislava, Slovakia

Book of Abstracts

Local Organizer: Peter Papp (Comenius University in Bratislava, Slovakia)

Action Chair: Petra Swiderek (University of Bremen, Germany)

Electron impact dissociative ionization of tetraethyl orthosilicate

Jelena Maljković¹, Peter Papp², Michal Lacko², Michal Stano², Aleksandar Milosavljević¹, Stefan Matejcik²

- (1) Laboratory for Atomic Collision Processes, Institute of Physics, University of Belgrade, Pregrevica 118, 11080 Belgrade, Serbia
- (2) Department of Experimental Physics, Faculty of Mathematics, Physics and Informatics, Comenius University, Mlynská dolina, 84248 Bratislava, Slovakia

e-mail: jelenam@ipb.ac.rs

We have investigated dissociative electron ionization of tetraethyl orthosilicate, TEOS ($\text{Si}(\text{OC}_2\text{H}_5)_4$), in gas phase, interesting as a possible Focused Electron Beam Induced Dissociation (FEBID) precursor. Measurements were performed at Comenius University on the crossed beams apparatus [1] and the cluster apparatus [2]. Both are equipped with trochoidal electron monochromator, which produces well collimated electron beam crossed perpendicularly with target. Positive ions formed with electron molecular interactions are extracted by a small electric field and recorded by quadrupole mass analyser. We have measured the possible pattern of fragmentation for TEOS molecule and compared with the NIST mass spectrum. Beside parent $M=(\text{Si}(\text{OC}_2\text{H}_5)_4)^+$ at m/z 208 many other positive ions were recorded in the mass spectrum, with many SiO_x^+ fragments ($x= 2, 3$ and 4) and their hydrogenated alternatives between m/z 60 and 100. Only the loss of 1 or 3 CH_3 or C_2H_5 was typical for TEOS, contrary to the loss of 1 or all 4 OC_2H_5 ligands. Alternative fragmentation paths were the loss of $2 \text{CH}_3 + \text{CH}_2\text{CH}_3$; $\text{CH}_3 + \text{C}_2\text{H}_5 + \text{OC}_2\text{H}_5$; $2 \text{C}_2\text{H}_5 + \text{OC}_2\text{H}_5$; $\text{CH}_3 + 2 \text{C}_2\text{H}_5 + \text{OC}_2\text{H}_5$. Beside that, measurements of threshold energies for all TEOS fragments have been done.

This work was supported by the Slovak Research and Development Agency under Contract No. APVV-0733-11; the Slovak grant agency VEGA V/0514/12; Ministry of Education and Science of Republic of Serbia (Project No. 171020). This work was conducted within the framework of the COST Action CM1301 (CELINA).

[1] M. Stano, S. Matejcik, J. D. Skalny and T. D. Märk, *Journal of Physics B: Atomic, Molecular and Optical Physics*, **36** (2003), 261

[2] O. Ingólfsson, F. Weik and E. Illenberger, *Int. Jour. Mass. Spec.* **155** (1996), 1

	Wednesday 6 th May, 2015	Thursday 7 th May, 2015	Friday 8 th May, 2015	Saturday 9 th May, 2015			
09:00		WG3 (30m) Stefan F. Rohrlack	WG2 (40m) Anjana Devi		09:00		
09:30	STSMs reports (20m)	WG2 (30m) Mats Tilset		WG3 (30m) Willem van Dorp	09:30		
09:40			WG1 Petr Carsky		09:40		
10:00		WG1 Rachel Thorman	WG1 Maciej Gutowski	WG1 Jelena Maljkovic	10:00		
10:20		Coffee	Coffee	Coffee	10:20		
10:40		WG1 Andrew Ellis	WG3 Hans Mulders	WG1 Ragesh Kumar	10:40		
11:00		WG1 Juraj Fedor	WG1 Lionel Amiaud	WG1 André Beyer	11:00		
11:20		WG3 Jelena Tamuliene	WG3 Francesc Salvat-Pujol	WG3 Sangeetha Hari	11:20		
11:40		WG1 Jonas Warneke	WG3 Thomas Verduin	Lunch & Departures	11:40		
12:00		Lunch	Lunch		12:00		
13:30	R E G I S T R A T I O N	Posters & MC Meeting	COST CM1301 WG Meetings		13:30		
15:40		Coffee			15:40		
16:00		WG3 (40m) Michael Huth	Conference Excursion			16:00	
16:40		WG2 (30m) Heinrich Lang				16:40	
17:10		WG2 Iwona Szymanska				17:10	
17:30		WG3 Marijke Scotuzzi				17:30	
17:50		Opening	WG1 Alex Laikhtman			17:50	
18:00		WG1 (40m) Howard Fairbrother	Individual Dinner in the City	Conference Dinner		18:00	
18:10							18:10
18:40		WG1 (30m) Stefan Matejczik					18:40
19:10	Welcome Reception				19:10		

PAPER • OPEN ACCESS

Study of electron transmission through a metallic capillary

To cite this article: A R Milosavljevi *et al* 2015 *J. Phys.: Conf. Ser.* **635** 062011

View the [article online](#) for updates and enhancements.

Related content

- [Electron transmission through macroscopic metallic capillaries](#)
D. Borka, K. Tökesi and C. Lemell
- [The Monte Carlo simulation of electron transmission through Al₂O₃ nanocapillary](#)
A. X. Yang, B. H. Zhu, X. M. Chen et al.
- [Energy dependence of electron transmission through a single glass capillary](#)
B S Dassanayake, S Das, R J Bereczky et al.

Study of electron transmission through a metallic capillary

A. R. Milosavljević¹, M. Lj. Ranković^{1*}, D. Borka², J. B. Maljković¹, R. J. Berezky³, B. P. Marinković¹ and K. Tőkési³

¹Institute of Physics Belgrade, University of Belgrade, Pregrevica 118, 11080 Belgrade, Serbia

²Vinča Institute of Nuclear Sciences, University of Belgrade, P.O. Box 522, 11001 Belgrade, Serbia

³Institute for Nuclear Research, Hungarian Academy of Sciences, H-4001 Debrecen, Hungary

Synopsis In this work we study the transmission of charged particles through a single cylindrically shaped metallic capillary of microscopic dimensions with a large aspect ratio. We used electrons as projectiles. Our results suggest the existence of guiding of the electron beam by a metallic capillary.

In this work we investigate the guiding of electrons through straight and narrow metallic capillaries. The investigation of guiding of charged particles by metal capillaries is strongly motivated by the possibility of producing cheap alternatives to complex electron-optical tools.

We have performed both the measurements and the classical calculations of electrons guiding [1, 2, 3]. Since electrons cannot change their charge state, it is experimentally impossible to make a clear distinction between transmission of the primary and secondary electrons which correspond to elastic scattering. But using the classical simulation, we can identify and follow up all electron trajectories. We performed Monte Carlo simulation assuming that after each inelastic collision a secondary electron is generated with kinetic energy directly estimated from the energy transfer [2, 3]. The created secondary electron is treated as a primary electron and the trace of its path is followed in the successive simulation procedure.

Our experimental setup consisted of an electron gun, a straight cylindrical platinum capillary, an energy analyzer and a channeltron as a detector. Pressure inside the vacuum chamber was 7×10^{-7} mbar. An inner radius of the capillary was 3.3 mm, with 40.8 mm in length. Estimated electron beam width at the entrance of the capillary was 0.9 mm with 0.3° angle divergence. The initial electron energy was 200 eV. We found that a dominant fraction of electrons escaping from the capillary have energies smaller than the incident electron energy. Figure 1. shows the energy spectrum of electrons transmitted through a cylindrical platinum capillary.

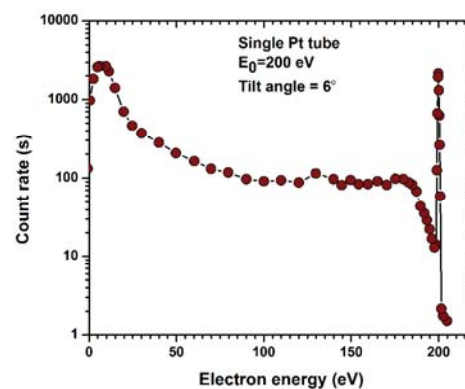

Figure 1. - Energy spectrum of electrons transmitted through platinum capillary [4].

This work was supported by the Ministry of education, science and technological development of Republic of Serbia under the Grants OI 171020 and III 45005, by the Hungarian SRF OTKA No. NN 103279, and by the Bilateral Cooperation Program between the Hungarian and Serbian Academies. This work was conducted within the framework of the COST Action CM1301 (CELINA).

References

- [1] A.R. Milosavljević *et al.* 2007 *Phys. Rev. A* **75** 030901(R).
- [2] K. Schiessl, K. Tőkési, B. Solleder, C. Lemell, J. Burgdörfer 2009 *Phys. Rev. Lett.* **102** 163201.
- [3] B.S. Dassanayake, R.J. Berezky, S. Das, A. Ayyad, K. Tőkési, J.A. Tanis 2011 *Phys. Rev. A* **83** 012707.
- [4] *Milosavljevic et al, NIMB 2015*

E-mail: mrankovic@ipb.ac.rs



15:20 - 15:40	<i>Jelena Maljkovic (University of Belgrade, Serbia)</i> Dissociative electron attachment to benzene chromium tricarbonyl
15:40 - 16:00	<i>Anita Ribar (Leopold-Franzens-Universität Innsbruck, Austria)</i> Low-Energy Electron Interaction with Tungsten Hexacarbonyl Clusters
16:00 - 16:20	Coffee break
16:20 - 19:00	Poster Session
17:00 - 19:00	MC meeting
19:00 -	Individual dinner in the city

Thursday, 19th of May	
Chairman: Oddur Ingolfsson	
9:00 - 9:40	<i>Simon Elliott (University College Cork, Ireland)</i> Introduction to Atomic Layer Deposition and the COST Action HERALD
9:40 - 10:10	<i>Armin Götzhäuser (Universität Bielefeld, Germany)</i> Nanopore Fabrication and Characterization by Helium Ion Microscopy
10:10 - 10:40	<i>Charlene Lobo (University of Technology Sydney, Australia)</i> Electron beam processes for surface functionalization and directed nanostructure assembly semiconductors
10:40 - 11:00	Coffee break
Chairman: Petra Swiderek	
11:00 - 11:30	<i>Hartmut Hotop (University of Kaiserslautern, Germany)</i> Michael Allan - electron impact spectroscopy at its best
11:30 - 12:00	<i>Ilya Fabrikant (University of Nebraska, USA)</i> Resonances and Threshold Effects in Electron Collisions with Molecules and Clusters
12:00 - 12:30	<i>Roman Curik (Academy of Sciences of the Czech Republic, Czech Republic)</i> Negative ion resonances of polyatomic molecules: are they relevant for search of FEBID precursors?
12:30 - 13:00	<i>Juraj Fedor (Academy of Sciences of the Czech Republic, Czech Republic)</i> Cluster-beam experiments and the insight they bring into FEBID
13:00 - 15:00	Lunch
15:00 - 18:30	Conference excursion: Krakow Old Town Walk
18:30 -	Conference dinner

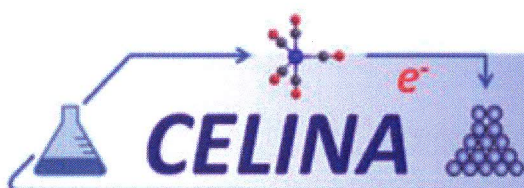

cost
EUROPEAN COOPERATION
IN SCIENCE AND TECHNOLOGY

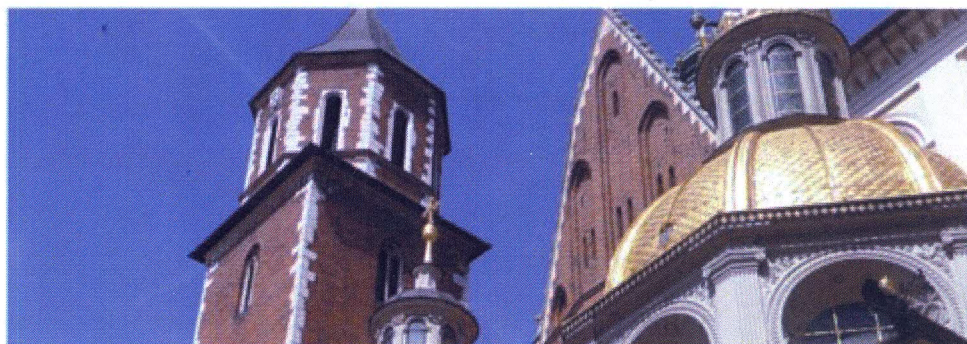
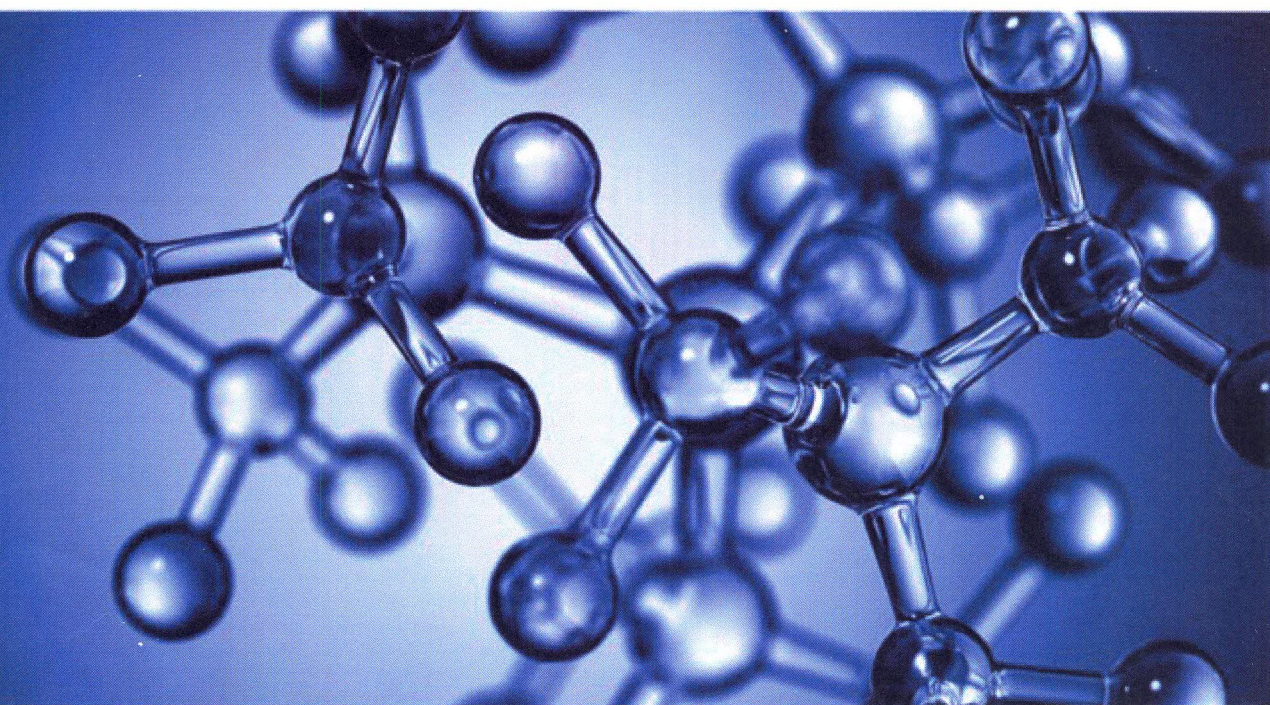

The 3rd CELINA Meeting

Kraków, May 18-20, 2016

Subject COST CELINA 2016_Invitation
From CELINA 2016 <celina2016@uph.edu.pl>
To <jelenam@ipb.ac.rs>
Date 2016-03-31 18:34
Priority Normal



Dear Dr Jelena Maljkovic,

On behalf of the organizers I would like to invite you to give a 20 min talk (15 + 5 min) on your recent work at the annual meeting of the COST Action CM1301 on Chemistry for Electron-Induced Nanofabrication (CELINA). The meeting will be held in Krakow, Poland the 18th to 20th of May 2016.

<http://www.celina.uni-bremen.de/celina/celina2016>

Please notify me at the earliest opportunity if you can accept this invitation.

Yours sincerely,
Janina Kopyra

DISSOCIATIVE ELECTRON ATTACHMENT TO BENZENE CHROMIUM TRICARBONYL

Jelena Maljković^{1*}, Paulina Maciejewska² and Janina Kopyra²

¹ *Laboratory for Atomic Collision Processes, Institute of Physics Belgrade,
University of Belgrade, Pregrevica 118, 11080 Belgrade, Serbia*

² *Faculty of Sciences, Siedlce University, 3 Maja 54, 08-110 Siedlce, Poland*

Abstract. We have investigated dissociative electron attachment to benzene chromium tricarbonyl, $M = Cr(C_6H_5)_3CO_3$. This molecule was in our interest because it is a possible Focused Electron Beam Induced Dissociation (FEBID) precursor. Measurements were done utilizing an experimental setup settled in Siedlce, Poland. The obtained mass spectra were recorded for the energies from 0 eV to 14 eV, with 2 eV step. The compound showed a very rich fragmentation pattern.

1. INTRODUCTION

In the present work a dissociative electron attachment (DEA) to benzene chromium tricarbonyl has been investigated. In DEA processes electron is captured by molecule forming a temporary negative ion, which can decompose into negative fragment and one or more neutral counterparts. This molecule has been in our interest because it is potential Focused Electron Beam Induced Deposition (FEBID) precursor. FEBID is a direct-writing technique in which the metallic deposit is deposited onto a substrate with nanometer resolution. In this technique a highly focused, high-energy electron beam impinges on a substrate and due to collisions produces lower energy back-scattered electrons and secondary electrons. It is nowadays very well known that these low energy electrons (LEEs) contribute to the processes resulting in the formation of the deposits. However, in the case when LEEs lead to partial fragmentation of the target molecules this results in the formation of deposit with limited purity and resolution.

The benzene chromium tricarbonyl molecule belongs to organometallic compounds. It has piano stool geometry with planar arrangement of aryl group and three carbonyl groups which act as "legs" (Figure 1). This molecule has been investigated previously. Rees and Copens [1] have been studied the crystal structure of this molecule at 78 K, both by X-ray and neutron diffraction. The electronic structure of transition metal in benzene chromium tricarbonyl has been

investigated by using SCF MO calculations [2]. Uemura and coauthors [3] have investigated direct regioselective lithiation of chromium benzenetricarbonyl.

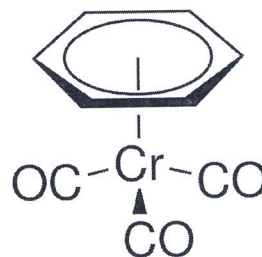

Figure 1. Structure of benzene chromium tricarbonyl molecule.

2. EXPERIMENT

The experiments were performed by means of crossed beam apparatus settled at Siedlce University, Poland. Description of the experimental set-up has been given elsewhere [4]. Briefly, it consists of a trochoidal electron monochromator (TEM), a quadrupole mass analyzer (QMA) and a secondary electron multiplier, all enclosed into vacuum chamber. Incident electron beam, with energy resolution of FWHM= 150-200meV and electron current $I \approx 10$ nA, orthogonally intersects with molecular beam resulting in the formation of fragment anions. Molecular beam emanates from the oven which was heated by two halogen bulbs. These lamps prevent condensation of the target molecules at the lenses and also provide sufficient vapour pressure of the target molecules and also provide stable experimental conditions. Working temperature was around 95 °C. Negative ions are extracted directly from the collision region by a small electric field, towards a QMA and detected by single pulse counting techniques. The calibration of the energy scale was achieved by measuring SF₆ signal, with intense resonance near 0 eV. Base pressure was in the range of $\sim 10^{-8}$ mbar while the working pressure around 3×10^{-5} mbar.

3. RESULTS

Preliminary results of dissociative electron attachment to benzene chromium tricarbonyl are shown. Resonant features of anion yields indicate that underlying processes are DEA, as the only effective below ionization energy, IE ≈ 7 eV [5]. Mass spectra has been obtained in the incident electron energy range from 0 eV up to 14 eV. Molecule showed rich anion formation: $(M - CO)^- = 186$ a.m.u., $(M - (CO)_2)^- = 158$ a.m.u., $(M - (CO)_3)^- = 130$ a.m.u., $(M - C_6H_6)^- = 136$ a.m.u., $Cr^- = 52$ a.m.u., $Cr(CO)^- = 80$ a.m.u., $(Cr(CO)_2)^- = 108$ a.m.u. and $Cr(CO)^- = 80$ a.m.u. The most intense reaction channel is the loss of one carbonyl group, which is also shown by other authors [6] in DEA process to W(CO)₆. Reaction channel associated with loss of all three CO groups, Figure 2, has a threshold

around 3eV. Three resonances are present in the anion yield curve. We can speak here about metastable decays, also shown in [6]. Sequential process, where $(M - CO)^-$ decays to $(M - (CO)_2)^-$ and $(M - (CO)_2)^-$ decays to $(M - (CO)_3)^-$ can occur in this presently studied compound.

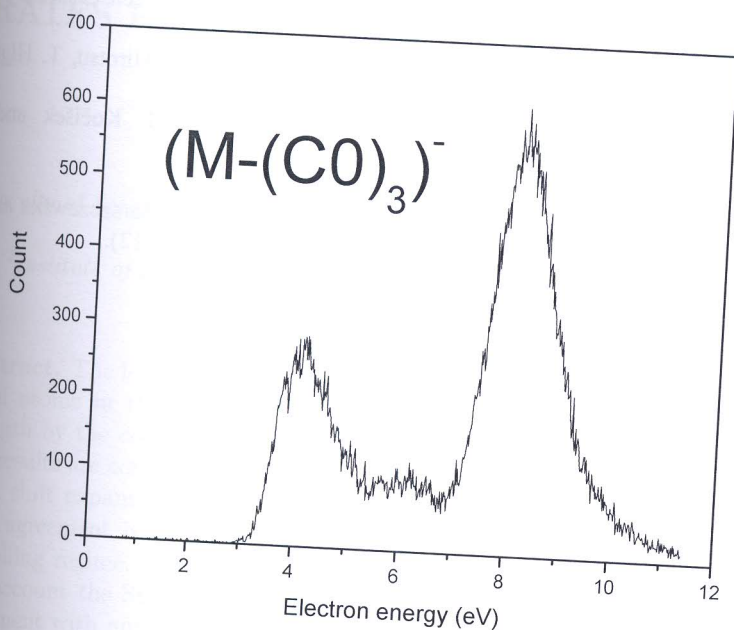

Figure 2. Anion yield of $(M - (CO)_3)^-$ formed by electron impact.

4. CONCLUSION

DEA processes have been investigated on benzene chromium tricarbonyl, a potential FEBID precursor. The obtained action tandem mass spectra have showed rich anion formation. The release of one, two and three CO groups has been noticed that is a consequence of a prompt decomposition of the temporary negative ion. In addition, a sequential processes can contribute to the overall intensity of the above mentioned fragment anions.

Acknowledgements

This work was supported by the Polish Ministry of Science and Higher Education (Project No. 277/S/11), Ministry of Education and Science of Republic of Serbia (Project No. 171020). This work was conducted within the framework of the COST Action CM1301 (CELINA).

REFERENCES

- [1] B. Rees and P. Copens, *Acta Cryst. B* 29, 2515 (1973).
- [2] M.F. Guesta, I.H. Hillierb, B.R. Higginsonc and D.R. Lloydc, *Molecular Physics: An International Journal at the Interface Between Chemistry and Physics*, 29, 113 (1975).
- [3] M. Uemura, N. Nishikawa, K. Take, M. Ohnishi, K. Hirotsu, T. Higuchi and Y. Hayashi, *J. Org. Chem.*, 48, 2349 (1983).
- [4] C. Koenig-Lehmann, J. Kopyra, I. Dabkowska, J. Kočíšek and E. Illenberger, *Phys. Chem. Chem. Phys.*, 10, 6954 (2008).
- [5] <http://www.webbook.nist.gov>
- [6] K. Wnorowski, M. Stano, C. Matias, S. Denifl, W. Barszczewska and S. Matejčík, *Rapid Commun. Mass Spectrom.* 26, 2093 (2012).



28th Summer School and
International Symposium on
the Physics of Ionized Gases

Aug. 29 - Sep. 2, 2016, Belgrade, Serbia

CONTRIBUTED PAPERS

&

**ABSTRACTS OF INVITED LECTURES,
TOPICAL INVITED LECTURES, PROGRESS REPORTS
AND WORKSHOP LECTURES**

Editors:

Dragana Marić, Aleksandar Milosavljević,
Bratislav Obradović and Goran Poparić



University of Belgrade,
Faculty of Physics



Serbian Academy
of Sciences and Arts

CEPAS 2017

7th Conference on Elementary Processes in Atomic Systems



3rd – 6th September 2017

Průhonice, Czech Republic



Electron transmission through steel capillary

B.P. Marinković¹, M.Lj. Ranković¹, J.B. Maljković¹, A.R. Milosavljević², D. Borka³, C. Lemell⁴, K. Tökesi⁵

¹*Institute of Physics Belgrade, University of Belgrade, Pregrevica 118, 11080 Belgrade, Serbia*

²*PLÉIADES beamline, Synchrotron SOLEIL, L'orme des Merisiers, Saint-Aubin - BP48, 91192 GIF-sur-YVETTE CEDEX, France*

³*Atomic Physics Laboratory, Vinča Institute of Nuclear Sciences, University of Belgrade, Belgrade, Serbia*

⁴*Institute for Theoretical Physics, Vienna University of Technology, Vienna, Austria*

⁵*Institute for Nuclear Research, Hungarian Academy of Sciences (ATOMKI), Debrecen, Hungary and ELI-ALPS, ELI-HU Non-profit Kft., Szeged, Hungary*

The transmission of low-energy electrons through platinum [1, 2] and steel capillaries have been investigated both experimentally and theoretically. The length of the present steel capillary was $L = 19.50$ mm while the inner diameter was $d = 0.90$ mm. Kinetic energy distribution of electrons transmitted through steel capillary was recorded at two tilt angles (the angle between the incident electron beam and the capillary axis) of 2.64° and 4.0° , respectively. The experimental results were obtained by an electron spectrometer which consists of an electron gun, a double cylindrical mirror energy analyzer (DCMA) and a channeltron detector.

Electron transmission is modelled by a classical trajectory Monte Carlo simulation taking both elastic and inelastic scattering events of primary electrons colliding with the inner wall of the capillary and transport of secondary electrons into account.

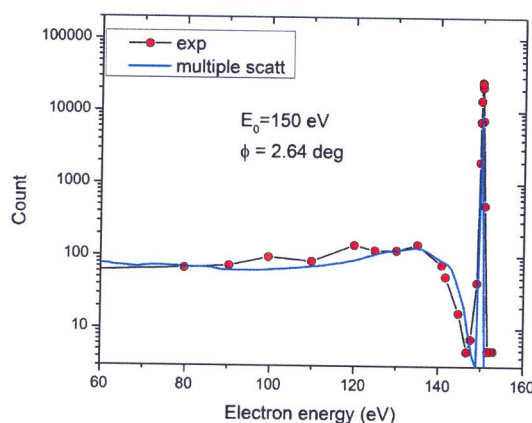

Figure 1: Energy spectra of electrons transmitted through a steel capillary.

Figure 1 shows energy spectra of 150 eV electrons passing through the steel capillary at 2.64° tilt angle. We found excellent agreement between our simulated electron-energy spectra with experimental data.

[1] A.R. Milosavljević *et al.*, Nucl. Instr. Meth. Phys. Res. B **354** (2015) 86.

[2] D. Borka *et al.*, Nucl. Instr. Meth. Phys. Res. B, in press (2017), <http://dx.doi.org/10.1016/j.nimb.2017.02.024>

Book of Abstracts

CELINA 2017 Porto Portugal

	Wednesday 13/09/2017	Thursday 14/09/2017	Friday 15/09/2017	Saturday 16/09/2017
08:45 - 09:00				
09:00 - 09:20		Petra Swiderik	Juraj Fedor	Mozaffar M. Shaveray
09:20 - 09:30		Syed Mansur Hameed		Anjaniban
09:30 - 09:50		Armin Ghaharloo	Marija Zlatar	Markus Bollenberg (STSM)
09:50 - 10:00		Ieri Iriani	Juraj Orasagh	
10:00 - 10:20		Tsabo Gebzali	Anita Ribar (STSM)	Kaja Hollich
10:20 - 10:40		Coffee	Coffee	Coffee
10:40 - 11:10			Enagh Huwailab (STSM)	Jainna Kopyra
11:10 - 11:30		Iwona Szymanska		Sylwia Pasinska
11:30 - 11:40			Lia McElwee-White	Gian Carlo Gazzadi (STSM)
11:40 - 11:50		Ivo Urke		Sascha Koch
11:50 - 12:00		Katarzyna Mardajska (STSM)	Discussion on laser activities (WS meeting)	all attendees contribute
12:00 - 12:10				Lunch
12:10 - 12:20		Lionel Anlaud		Lunch
12:20 - 12:30				Lunch
12:30 - 12:50				Lunch
12:50 - 14:00				
14:00 - 14:30		Sven Barth		
14:30 - 15:00				
15:00 - 15:30	Registration			Departure
15:30 - 15:50				
15:50 - 19:00				
19:00 - open end				

CELINA overview and synthetic perspectives
Novel developments in FEBID and beyond
Carboxylate precursors
Bimetallic precursors
Neutral excitation and dissociation
Process gases for deposit purification and lithography
Improved control over electron-driven processing
General

P-11: Dissociative electron attachment to cyclopentadienylmanganese(I) tricarbonyl

Jelena Maljković^{1*}, Sylwia Mazuryk², and Janina Kopyra²

¹Laboratory for Atomic Collision Processes, Institute of Physics Belgrade, University of Belgrade, Pregrevica 118, 11080 Belgrade, Serbia

²Faculty of Sciences, Siedlce University, 3 Maja 54, 08-110 Siedlce, Poland

In the present work a dissociative electron attachment (DEA) to cyclopentadienylmanganese(I) tricarbonyl, $(C_5H_5)Mn(CO)_3$, has been investigated. Molecule can be considered as potential FEBID precursor. This sample has extremely high sublimation rate and adsorb on filament of ion gauge, so measurements were hard to perform. Measurements were done utilizing an experimental setup [1] settled in Siedlce, Poland. Briefly, it consists of trochoidal electron monochromator (TEM), quadrupole mass analyzer (QMA) and secondary electron multiplier, all enclosed into vacuum chamber. Incident electron beam, with energy resolution of $FWHM \approx 160\text{meV}$, orthogonally crossed with molecular beam resulting in the formation of fragment anions. The obtained mass spectra were recorded for the energies from 0 eV to 8 eV, with 2 eV step. The compound showed weak features, at energy near 0 eV, that are due to the loss of one or two carbonyl groups: $(M - CO)^- = 176\text{ a.m.u.}$, $(M - (CO)_2)^- = 148\text{ a.m.u.}$ Temperature was around 45°C and the pressure around $4.4 \times 10^{-7}\text{ mbars}$.

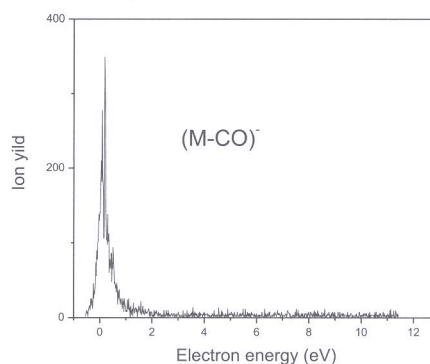

Fig.1. Ion yield of $(M - CO)^-$, produced from electron impact on gaseous cyclopentadienylmanganese(I) tricarbonyl.

References

- [1] C. Koenig-Lehmann, J. Kopyra, I. Dabkowska, J. Kočišek and E. Illenberger, *Phys. Chem. Chem. Phys.*, **10**, (2008), 6954

MPS '18



**INTERNATIONAL CONFERENCE
ON MANY PARTICLE SPECTROSCOPY
OF ATOMS, MOLECULES, CLUSTERS
AND SURFACES**



**BUDAPEST, HUNGARY
21-24 AUGUST 2018**

**PROGRAMME AND
BOOK OF ABSTRACTS**

**International Conference on Many Particle Spectroscopy of
Atoms, Molecules, Clusters and Surfaces**

Budapest, Hungary

21-24 August 2018



**Programme
and
Book of Abstracts**

Local Organizing Committee

Károly Tőkési (Chair)

Arnold Farkas

Henrik Haspel

Zoltán Kónya

Béla Paripás

Gábor Pszota

Web address: mpsbudapest2018.com

E-mail: mpsbudapest2018@gmail.com

Organized by
EKHO' 94 Ltd., Debrecen

Venue
Danubius Hotel Flamenco, Budapest, 3-7 Tas vezér str., 1113

Conference Issue

Papers submitted to the conference will be published following the conference in a Topical Issue (Many Particle Spectroscopy of Atoms, Molecules, Clusters and Surfaces) of EPJD: Atomic, Molecular, Optical and Plasma Physics.
Guest Editors: K. Tókési, B. Paripás, G. Pszota, and A V Solov'yov

Programme and Book of Abstracts

This book contains the programme of the International Conference on Many Particle Spectroscopy of Atoms, Molecules, Clusters and Surfaces held from 21-24 August 2018 in Budapest. Hungary and

the camera-ready copies of the abstracts as sent by the authors. In few cases only minor corrections were made.

Editors: K. Tókési, B. Paripás, G. Pszota

Printed by: Rexpo Ltd.
ISBN 978-615-00-2859-0



Preface

Welcome to the International Conference on Many Particle Spectroscopy of Atoms, Molecules, Clusters and Surfaces, MPS-2018, organized in Budapest, Hungary, from 21 to 24 August 2018. The objective of MPS-2018 is to assess the state of the art in the current understanding of a variety of basic phenomena in the charged particle dynamics in atoms, molecules, clusters and at surfaces such as a) collision induced physical, chemical and biological reactions, b) ultrafast dynamics, c) charge-exchange processes, d) collective as well as single-particle excitation and ionization, e) electron-electron correlation effects in atoms and in solids, f) excitation and single and multiple ionization of various targets, g) energy loss, scattering and channeling of primary particles, and h) electron and photon emission processes.

MPS is a biannual meeting. The aim is to promote the growth and exchange of scientific information on these areas of atomic and molecular and surface physics. The most recent meetings have been held in Moscow (Russia, 2016) Metz (France, 2014), Berlin (Germany, 2012), Sendai (Japan, 2010), Paris (France, 2008), Rome (Italy, 2006).

Hungary is a landlocked country in the Carpathian Basin in Central Europe, bordered by Austria, Slovakia, Ukraine, Romania, Serbia, Croatia and Slovenia. Its capital is Budapest. Hungary has been a member state of the European Union since 1 May 2004.

The conference is held at the Danubius Hotel Flamenco (Address: 3-7 Tas vezér str., 1113 Budapest), the most modern conference centre in Budapest.

Hotel Flamenco offers something rare – accommodation close to the centre of Budapest yet surrounded by beautiful parkland. This four-star hotel near the so-called “Bottomless Lake” in Budapest’s 11th district has its own garage and rooftop car park, although it’s also easily accessible by public transport with metro, bus and tram stops a short walk away. Hotel Flamenco is also an ideal venue for events. Its conference rooms come in various sizes, making it equally suitable for hosting smaller conferences and major events for several hundred people.

We hope that all participants will have a lively and successful meeting while enjoying the attractive surroundings in this beautiful region of Hungary. We hope, furthermore, we may offer exciting scientific programs and last but not least famous Hungarian dishes and wines. Organizers have been doing their best to guarantee pleasant experiences for everyone.

On behalf of the local organizing committee,

Károly Tökési

Chair of MPS-2018

International Advisory Board

Ugo Ancarani (France)
Lorenzo Avaldi (Italy)
Klaus Bartschat (USA)
Jamal Berakdar (Germany)
Nora Berrah (USA)
Igor Bray (Australia)
XiangJun Chen (China)
Piero Decleva (Italy)
Mevlut Dogan (Turkey)
Danielle Dowek (France)
Reinhard Dörner (Germany)
Alexander Dorn (Germany)
Anatoly Faenov (Japan)†
Omar Fojon (Argentina)
Alexei Grum-Grzhimailo (Russia)
Laszlo Gulyas (Hungary)
Tom Kirchner (Canada)
Konstantin Kouzakov (Russia)
Edwin Kukk (Finland)
Don Madison (USA)
Fernando Martin (Spain)
Andrew Murray (UK)
Bernard Piraux (Belgium)
Ivan Powis (UK)
Emma Sokell (Ireland)
Magda Staicu-Casagrande (France)
Masahiko Takahashi (Japan)
Károly Tókési (Hungary)
Lokesh Tribedi (India)
Kiyoshi Ueda (Japan)
Jim Williams (Australia)

Scientific Program

August 2018, Tuesday

16:00 – 20:00 Registration

18:00 – 19:30 Cheese and wine reception

22 August 2018, Wednesday

Femto-, attosecond physics and imaging (Chair: Edwin Kukk)

8:40 – 9:00	Opening	Károly Tökési, Norbert Kroó
9:00 – 9:30	Fernando Martin Universidad Autónoma de Madrid, Spain	<i>Attosecond coupled electron and nuclear dynamics in molecules</i>
9:30 – 10:00	Nora Berrah University of Connecticut, Storrs, USA	<i>C60 femtosecond dynamics induced by the LCLS X-ray FEL</i>
10:00 – 10:30	Florian Trinter DESY, Hamburg, Germany	<i>Imaging the correlated two-electron wave function of a hydrogen molecule</i>

Coffee Break (10:30 – 11:00)

Photoionization I. (Chair: Emma Sokell)

11:00 – 11:30	Liang-You Peng Peking University, Beijing China	<i>Few-photon double ionization of Helium</i>
11:30 – 11:50	Maria-Novella Piancastelli Sorbonne Université, Paris, France	<i>Photoexcitation and photoionization dynamics of isolated atoms and molecules in the tender x-ray domain</i>
11:50 – 12:10	Stephan Fritzsche Universität Jena, Germany	<i>Excitation and ionization of atoms by twisted light</i>
12:10 – 12:30	Francis Penent Sorbonne Université, Paris, France	<i>Multiple photoionization of alkali atoms</i>

Lunch (12:30 – 14:00)

Laser field I. (Chair: Nora Berrah)

14:00 – 14:30	Elena V. Gryzlova Lomonosov Moscow State University, Russia	<i>Ionic autoionizing states studied with free-electron lasers</i>
14:30 – 15:00	Diego G. Arbó IAFE (UBA-CONICET), Buenos Aires, Argentina	<i>Retrieving intracycle interference in angle-resolved laser assisted XUV atomic ionization</i>
15:00 – 15:20	Philipp V. Demekhin Universität Kassel, Germany	<i>Correlative two-electron dynamics in helium driven by intense laser pulses</i>
15:20 – 15:40	Barna Imre Wigner Research Centre for Physics, Budapest, Hungary	<i>Electron scattering and conduction in doped semiconductors in simultaneous strong infrared radiation field</i>

Coffee Break (15:40 – 16:10)

Laser field II. (Chair: Alisher Kadyrov)

16:10 – 16:40	Akiyoshi Hishikawa Nagoya University, Japan	<i>Photoelectron transversal momentum distribution from D2 in circularly polarized intense laser fields</i>
16:40 – 17:10	Nicolas Camus MPIK, Heidelberg, Germany	<i>Experimental studies of Wigner's tunnelling time</i>

17:10 – 18:30 Poster session (P1 - P54)

23 August 2018, Thursday

Photoionization II. (Chair: Shaofeng Zhang)

9:00 – 9:30	Nicolas Sisourat Sorbonne Université, Paris, France	<i>Interatomic Coulombic Decay in triatomic and more complex systems</i>
9:30 – 9:50	Eliezer Kolodney Technion - Israel Institute of Technology, Haifa Israel	<i>Postcollision (delayed) fission and multifragmentation in fullerene-surface impact: experiment and simulation</i>
9:50 – 10:10	Yuki Orimo The University of Tokyo, Japan	<i>Ab initio simulations of photoelectron energy spectra from multielectron systems subject to intense laser fields</i>
10:10 – 10:30	Stepan Balybin Lomonosov Moscow State University, Russia	<i>Enhancement of ionization of atoms in bright squeezed vacuum light</i>

Coffee Break (10:30 – 11:00)

Interactions with molecules I. (Chair: Lorenzo Avaldi)

11:00 – 11:30	Da Bo National Institute for Materials Science, Tsukuba, Japan	<i>Virtual Substrate Method for Nanomaterials Characterization</i>
11:30 – 11:50	Victor Despre Universitat Heidelberg, Germany	<i>Charge migration in propiolic acid and its dephasing by the coupling to the nuclear motion</i>
11:50 – 12:10	Moustafa Zmerli Sorbonne Université, Paris(05), France	<i>Charge transfer and nuclear dynamics after methyl iodide core ionization following single photon absorption</i>
12:10 – 12:30	Raimund Feifel University of Gothenburg, Sweden	<i>Ultrafast molecular three-electron collective Auger decay</i>

Lunch (12:30 – 14:00)

Interactions with molecules II. (Chair: Sebastian Otranto)

14:00 – 14:30	Miriam Weller Goethe-Universität Frankfurt, Germany	<i>Time-resolved Studies of Molecular Systems Using Synchrotron Radiation</i>
14:30 – 15:00	Kilian Fehre Goethe-Universität Frankfurt, Germany	<i>Strong Field Ionization of Chiral Molecules</i>
15:00 – 15:20	Mohammad F. Gharaibeh Qatar University, Doha, Qatar	<i>K-shell photoionization of molecular oxygen-ions</i>
15:20 – 15:40	Nikolay Shvetsov Leibniz Universität Hannover, Germany	<i>Semiclassical two-step model and strong-field ionization of hydrogen molecule</i>

Coffee Break (15:40 – 16:10)

More complex systems (Chair: Piero Decleva)

16:10 – 16:40	Péter Dombi Wigner Research Centre for Physics, Budapest, Hungary	<i>Photoelectron spectroscopy for ultrasensitive measurement of plasmon fields</i>
16:40 – 17:00	Hicham Agueny University of Bergen, Norway	<i>Electron dynamics in single-cycle THz pulses</i>

17:00 – 18:30 **Poster session (P55 – P108)**

19:30 – **Conference dinner**

24 August 2018, Friday**Electron collisions** (Chair: Alexander Dorn)

9:00 – 9:30	Jelena Maljković Institute of Physics Belgrade, Serbia	<i>Elastic electron scattering by triethyl phosphate molecule – experimental and theoretical study</i>
9:30 – 10:00	Zehra N. Ozer Afyon Kocatepe University, Afyon, Turkey	<i>Experimental and theoretical investigation of triple differential cross sections of CO₂ molecule at intermediate electron energy</i>
10:00 – 10:30	Matthieu Genevriez Universit e Catholique de Louvain, Belgium	<i>Absolute cross section for electron-impact ionization of He(1s2s ³S)</i>

Coffee Break (10:30 – 11:00)**Collision with molecular systems** (Chair: Stephan Fritzsche)

11:00 – 11:30	Noboru Watanabe Tohoku University, Sendai, Japan	<i>Stereodynamics in electron-impact ionization of molecules studied by molecular-frame electron energy loss spectroscopy</i>
11:30 – 11:50	Vishant Kumar Normandie Université, Caen, France	<i>Investigating the fragmentation dynamics and geometry of CO molecular clusters</i>
11:50 – 12:10	Zoltán Jurek Center for Free-Electron Laser Science, Hamburg, Germany	<i>Chemical dynamics in Argon clusters induced by intense x-rays</i>
12:10 – 12:30	Isabella Floss Vienna University of Technology, Austria	<i>Multi-scale simulation of high harmonic generation in condensed matter</i>

Lunch (12:30 – 14:00)**Heavy particle collisions** (Chairs: Nicolas Sisourat/ Nikolay Shvetsov-Shilovskiy)

14:00 – 14:30	Ilkhom Abdurakhmanov Curtin University, Perth, Australia	<i>Calculating fully differential cross section for ionization of H and He by heavy projectiles</i>
14:30 – 14:50	Richard A. Wilhelm Vienna University of Technology, Austria	<i>Ultrafast neutralization dynamics of highly charged ions upon impact on atomically thin solid targets"</i>
14:50 – 15:10	Luca Repetto Università di Genova, Italy	<i>Ion induced self-organization of form birefringent Cr-Si subwavelength optical gratings</i>
15:10 – 15:30	Alisher Kadyrov Curtin University, Perth, Australia	<i>Quantum suppression of antihydrogen formation in positronium-antiproton collisions</i>
15:30 – 15:50	Örs Asztalos Budapest University of Technology and Economics, Hungary	<i>Application of Collisional Radiative models in Beam Emission Spectroscopy modeling for fusion plasma density diagnostics</i>
15:50 – 16:10	Sebastian Otranto Instituto de Física del Sur Bahía Blanca, Argentina	<i>Ion impact ionization of H₂O at intermediate energies: the role of multiple electron removal</i>

16:10 – Final remarks**16:30 – End of Meeting**

Invited lecturers

Ilkhom Abdurakhmanov

Calculating fully differential ionization cross section of H and He upon heavy projectile impact
Department of Physics, Astronomy and Medical Radiation Sciences, Curtin University, GPO Box U1987,
Perth 6845, Australia

Diego Arbó

Retrieving intracycle interference in angle-resolved laser assisted XUV atomic ionization
Institute for Astronomy and Space Physics - IAFE, Buenos Aires, Argentina

Nora Berrah

X-ray induced time-resolved dynamics in Fullerenes
University of Connecticut Department of Physics, USA

Nicolas Camus

Experimental studies of Wigner's tunneling time
Max-Planck-Institut für Kernphysik, Heidelberg, Germany

Bo Da

Virtual Substrate Method for Nanomaterials Characterization
Research and Services Division of Materials Data and Integrated System, National Institute for Materials
Science, Tsukuba, Ibaraki 305-0047, Japan

Péter Dombi

Photoelectron spectroscopy for ultrasensitive measurement of plasmon fields
Wigner Research Centre for Physics, Budapest

Kilian Fehre

Strong Field Ionization of Chiral Molecules
Institut für Kernphysik, Johann Wolfgang Goethe Universität, Max-von-Laue-Strasse 1, 60438 Frankfurt am
Main, Germany

Matthieu Génévriez

Absolute cross section for electron-impact ionization of He(1s2s 3S)
Laboratory for Physical Chemistry, ETH Zürich, Switzerland.

Elena Gryzlova

Ionic autoionizing states studied with free-electron lasers
Lomonosov Moscow State University, Skobeltsyn Institute of Nuclear Physics, Moscow, Russia

Akiyoshi Hishikawa

Manipulating atoms and molecules by intense laser fields
Department of Chemistry, Graduate School of Science, Nagoya University, Nagoya, Japan

Jelena Maljković

Elastic electron scattering by triethyl phosphate molecule – experimental and theoretical study
Institute of Physics Belgrade, Serbia

Fernando Martin

Attosecond coupled electron and nuclear dynamics in molecules
Departamento de Química, Módulo13, Universidad Autónoma de Madrid, 28049 Madrid, Spain

Zehra Nur Özer

Experimental and theoretical investigation of triple differential cross sections of CO₂ molecule at intermediate electron energy

Afyon Kocatepe University, Physics Department, Turkey

Laing-You Peng

Few-Photon Double Ionization of Helium.

School of Physics, Peking University, 100871, Beijing, China

Nicolas Sisourat

Interatomic Coulombic Decay in triatomic and more complex systems

Sorbonne Universités, UPMC Univ Paris 06, CNRS, Laboratoire de Chimie Physique Matière et Rayonnement, F-75005, Paris, France

Florian Trinter

Imaging the correlated two-electron wave function of a hydrogen molecule

Deutsches Elektronen-Synchrotron (DESY), FS-PE, Notkestrasse 85, 22607 Hamburg, Germany and Fritz-Haber-Institut der Max-Planck-Gesellschaft, Molecular Physics, Faradayweg 4, 14195 Berlin, Germany

Noboru Watanabe

Stereodynamics in electron-impact ionization of molecules studied by molecular-frame electron energy loss spectroscopy

Institute of Multidisciplinary Research for Advanced Materials Tohoku University, Sendai, Japan

Miriam Weller

Time-resolved Studies of Molecular Systems Using Synchrotron Radiation

Institut für Kernphysik, Goethe-University Frankfurt am Main, Germany

Elastic electron scattering by triethyl phosphate molecule – experimental and theoretical study

J. Vuković¹, B. P. Marinković², B. Predojević¹, K. Tökési^{3,4}, J. Maljković²

¹Faculty of Natural Sciences, University of Banja Luka, Republic of Srpska, Bosnia and Herzegovina

²Institute of Physics Belgrade, University of Belgrade, Pregrevica 118, 11080 Belgrade, Serbia

³Institute for Nuclear Research, Hungarian Academy of Sciences (ATOMKI), Debrecen, Hungary

⁴ELI-ALPS, ELI-HU Non-profit Kft., Szeged, Hungary

Corresponding author: jelena.maljkovic@ipb.ac.rs

Electron elastic differential cross sections (DCS) of triethyl phosphate molecule ($(C_2H_5)_3PO_4$) have been investigated both experimentally and theoretically. Beside its role as a polymer resin modifier or a common intermediate in the manufacture of pesticides [1], triethyl phosphate molecule can serve as a model for radiation damage of the phosphate group as a part of DNA backbone (Fig.1).

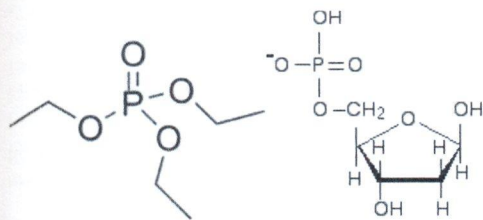

Figure 1. The skeletal formula of (a) triethyl phosphate molecule and (b) a phosphate group attached to the sugar molecule in place of the -OH group on the 5' carbon atom in DNA backbone.

The home-made experimental setup is based on a crossed beam technique comprising of an electron gun, a single capillary gas needle and a detection system with a channeltron [2], while construction of a gas line used for relative low technique, design and programming of digital acquisition system are detailed in [3]. DCS data as function of scattering angle, $DCS(\theta)$, is obtained by measuring the signal and background for each angle point. For the relative flow measurements argon gas was taken as a reference gas and the absolute cross sections have been used from the recent measurements in our group [4].

The partial expansion method was used to describe the differential and total cross sections for electron elastic scattering. The method of calculations can be found in reference [5].

Measurements have been performed at several electron impact energies, i.e. 50, 100,

150 200 and 250 eV and in the angular range from 25° to 125° . In Fig.2 measured and calculated DCS at 100 eV are shown. Both sets of data are arbitrary normalized at the same point at 40° scattering angle.

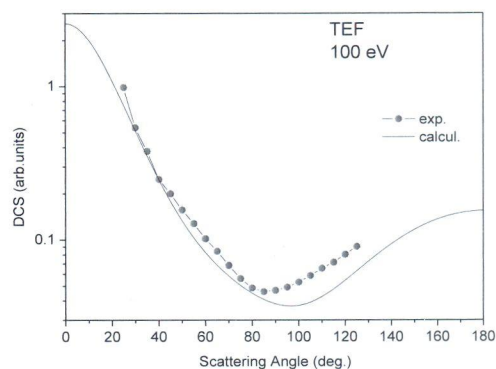

Figure 2. The experimental and calculated differential cross sections for electron elastic scattering by triethyl phosphate molecule at 100 eV impact energy. Both curves are normalized at scattering angle of 40 degrees.

The comparison in shape between experimental and calculated gives a good agreement. Still, we need to match the absolute scales and to estimate the uncertainties.

References

- [1] D. Betteridge, M. Thompson, A.D. Baker, and N.R. Kemp, *Analytical Chem.*, (1972) 44, 2005.
- [2] A.R. Milosavljević, S. Madžunkov, D. Šević, I. Čadež, B.P. Marinković, *J. Phys. B* (2006) **39**, 609.
- [3] J.B. Maljković, A.R. Milosavljević, F. Blanco, D. Šević, G. García, B.P. Marinković, *Phys. Rev. A* (2009) **79**, 052706.
- [4] Miloš Lj. Ranković, Jelena B. Maljković, Károly Tökési, and Bratislav P. Marinković, *Nucl. Instrum. Meth. B* (2018) **72**, 30.
- [5] F. Salvat, R. Mayol, *Comput. Phys. Commun.* (1993) **74**, 358

Absolute cross section for electron-impact ionization of He(1s2s ³S)

M. Génévriez^{*,†}, J. J. Jureta^{*}, P. Defrance^{*}, X. Urbain^{*}

^{*} Institute of Condensed Matter and Nanosciences, Université Catholique de Louvain, Louvain-la-Neuve, Belgium

[†] Laboratory of Physical Chemistry, ETH Zurich, Zurich, Switzerland

Corresponding author: matthieu.genevriez@phys.chem.ethz.ch

Electron-impact ionization of ground state helium is a benchmark process which, as such, has been extensively studied. Good agreement is now reached between the results of state-of-the-art theoretical and experimental investigations. The case of electron-impact ionization of the metastable, 1s2s ³S state of helium is far from being as satisfactory. For example, despite sustained theoretical effort within the past decades, the only measurement of the absolute total ionization cross section which spans a significant energy range [4] lies more than 60% higher than the results of all recent, state-of-the-art calculations (see, *e.g.*, [3, 5]). This difference is not acceptable due to the importance of metastable helium in a wide variety of physical environments and processes, from Bose-Einstein condensates to diagnosis of thermonuclear fusion plasmas.

We have measured the absolute cross sections for electron-impact single and double ionization of He(1s2s ³S) and for double ionization of He⁻ [1], using the animated-crossed-beam technique of Defrance *et al.* [2]. A source of fast metastable helium atoms was purpose-built for this study and overcomes the lack of state selectivity existing in the earlier experiment. It is based on the photodetachment of fast (keV) He⁻ ions by a CO₂ laser, which ensures that atoms are produced in the 1s2s ³S state only. A relatively high beam brightness can be reached due to the large detachment efficiency, and purity is better than 5% with contamination limited to He(1s² ¹S) only.

The present results for single ionization of He(1s2s ³S) lie significantly lower than the previous experiment, and are in fact in the region reached by recent, *ab initio* calculations [1]. They are in excellent agreement with the multi-core calculation of Fursa and Bray [3], as shown in Fig. 1, over the whole energy range covered. Frozen-core calculations fail to match the present results at higher energies, hinting at significant contributions from inner-shell ionization and indirect mechanisms such as excitation to doubly excited states and autoionization.

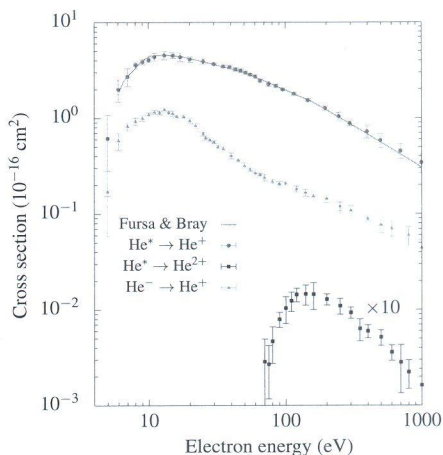

Figure 1. Cross sections for electron-impact single and double ionization of He(1s2s ³S) and double ionization of He⁻.

Results for the double ionization of metastable helium and He⁻ are the first data reported in the literature for these processes. The cross section for double ionization of He(1s2s ³S) has roughly the same magnitude as that for ground state helium, suggesting that ionization of the second (1s) electron is the limiting factor. The cross section for double ionization of He⁻ is much larger than typical values, as expected for such a weakly bound system (77 meV), and does not match for universal shape of Rost and Pattard [6].

References

- [1] M. Génévriez *et al.* 2017 *Phys. Rev. A* 96 010701(R)
- [2] P. Defrance *et al.* 1981 *J. Phys. B* 14 103
- [3] D. V. Fursa and I. Bray 2003 *J. Phys. B* 36 1663
- [4] A. J. Dixon *et al.* 1976 *J. Phys. B* 9 2617
- [5] Y. Ralchenko *et al.* 2008 *At. Data Nucl. Data Tables* 94 603
- [6] J. M. Rost and T. Pattard 1999 *J. Phys. B* 32 603

August 22, 2018 Wednesday		August 23, 2018 Thursday		August 24, 2018 Friday	
Femto-, attosecond physics (Chair: Edwin Kukk)		Photoionization II. (Chair: Shaofeng Zhang)		Electron collisions (Chair: Alexander Dorn)	
8:40 – 9:00	<i>Opening</i> Norbert Kroó	9:00 – 9:30	Nicolas Sisourat	9:00 – 9:30	Jelena Maljković
9:00 – 9:30	Fernando Martin	9:30 – 9:50	Eliezer Kolodney	9:30 – 10:00	Zehra N. Ozer
9:30 – 10:00	Nora Berrah	9:50 – 10:10	Yuki Orimo	10:00 – 10:30	Matthieu Genevriez
10:00 – 10:30	Florian Trinter	10:10 – 10:30	Stepan Balybin		
10:30 – 11:00	Coffee Break	10:30 – 11:00	Coffee Break	10:30 – 11:00	Coffee Break
Photoionization I. (Chair: Emma Sokell)		Interactions with molecules I. (Chair: Lorenzo Avaldi)		Coll. with molecular syst. (Chair: Stephan Fritzsche)	
11:00 – 11:30	Liang-You Peng	11:00 – 11:30	Da Bo	11:00 – 11:30	Noboru Watanabe
11:30 – 11:50	Maria-Novella Piancastelli	11:30 – 11:50	Victor Despre	11:30 – 11:50	Vishant Kumar
11:50 – 12:10	Stephan Fritzsche	11:50 – 12:10	Moustafa Zmerli	11:50 – 12:10	Zoltán Jurek
12:10 – 12:30	Francis Penent	12:10 – 12:30	Raimund Feifel	12:10 – 12:30	Isabella Floss
12:30 – 14:00	Lunch	12:30 – 14:00	Lunch	12:30 – 14:00	Lunch
Laser field I. (Chair: Nora Berrah)		Interactions with molecules II. (Chair: Sebastian Otranto)		Heavy particle collisions (Chairs: Nicolas Sisourat/ Nikolay Shvetsov-Shilovski)	
14:00 – 14:30	Elena V. Gryzlova	14:00 – 14:30	Miriam Weller	14:00 – 14:30	Ilkhom Abdurakhmanov
14:30 – 15:00	Diego G. Arbó	14:30 – 15:00	Kilian Fehre	14:30 – 14:50	Richard A. Wilhelm
15:00 – 15:20	Ph. V. Demekhin	15:00 – 15:20	Moh. F. Gharaibeh	14:50 – 15:10	Luca Repetto
15:20 – 15:40	Imre Barna	15:20 – 15:40	Nikolay Shvetsov-Shilovski	15:10 – 15:30	Alisher Kadyrov
15:40 – 16:10	Coffee Break	15:40 – 16:10	Coffee Break	15:30 – 15:50	Őrs Asztalos
				15:50 – 16:10	Sebastian Otranto
Laser field II. (Chair: Alisher Kadyrov)		More complex systems (Chair: Piero Decleva)		16:10 – 16:30	Final remarks
16:10 – 16:40	Akiyoshi Hishikawa	16:10 – 16:40	Péter Dombi	16:30	End of the conference
16:40 – 17:10	Nicolas Camus	16:40 – 17:00	Hicham Agueny		
17:10 – 18:30	Poster session	17:00 – 18:30	Poster session		
		19:30	Conference dinner		



УНИВЕРЗИТЕТ У БЕОГРАДУ
ФИЗИЧКИ ФАКУЛТЕТ

Бр. 12911
19. 4. 20 22. год.
БЕОГРАД, СТУДЕНТСКИ ТРГ 12-10
П. ФАХ 44

ПОТВРДА

Овим се потврђује да је **др ЈЕЛЕНА МАЉКОВИЋ**, научни сарадник Института за физику руководила изработом мастер рада ЈЕЛЕНЕ ВУКОВИЋ под називом "АПСОЛУТНИ ПРЕСЕЦИ ЗА ЕЛЕАСТИЧНО РАСЕЈАЊЕ ЕЛЕКТРОНА НА МОЛЕКУЛУ ТРИЕТИЛ-ФОСФАТА", који је одбрањен на Физичком факултету Универзитета у Београду 24. септембра 2018. године.

Др Јелена Маљковић је за ментора мастер рада ЈЕЛЕНЕ ВУКОВИЋ именована на седници Наставно-научног већа Физичког факултета одржаној 18. октобра 2017. године.

Београд, 19.4.2022.



ДЕКАН ФИЗИЧКОГ ФАКУЛТЕТА

Проф. др Иван Белча

MPS '18



The International Conference on Many Particle Spectroscopy of Atoms,
Molecules, Clusters and Surfaces MPS-2018 (21-24 August, 2018)

Date: Debrecen, 25. June 2018.

Dear Prof. Jelena Maljkovic!

As the chairman of the Local Organizing Committee of MPS'18 (The International Conference on Many Particle Spectroscopy of Atoms, Molecules, Clusters and Surfaces), it is my pleasure to invite you to participate in the MPS'18 to be held in Budapest, Hungary from 21-24 August 2018.

Your contributed paper entitled "Elastic electron scattering by triethyl phosphate molecule – experimental and theoretical study" has been selected and accepted for invited talk presentation at the conference. MPS is a biannual meeting, which deals with physical and chemical phenomena induced by the interaction of charged particles (singly up to highly charged ions, atoms and clusters, electrons) and photons with atoms, molecules, clusters and surface and the bulk of solids and also liquids. The aim is to promote the growth and exchange of scientific information on these areas of atomic and molecular and surface physics.

Please note, however, that this invitation does not imply an obligation for financial support from the conference organizers.

The MPS-2018 organizers encourage you to apply for the visa (if needed) as early as possible. You may find more details concerning to visa issues on our official webpage: <http://mpsbudapest2018.com>

We are looking forward to welcoming you in Budapest!

Yours sincerely,

Prof. Dr. Károly Tőkési

Chairman

Conference Organizing Committee, MPS'18

Универзитет у Београду ФИЗИЧКИ ФАКУЛТЕТ
Студентски трг 12, 11000 Београд
Поштански фах 44
Тел. 011 7158 151, 3281 375
ПИБ 100039173, Мат. бр. 07048190



University of Belgrade FACULTY OF PHYSICS
Studentski trg 12, 11000 Belgrade
Postal Box 44
Phone +381 11 7158 151, Fax +381 11 3282 619
www.ff.bg.ac.rs, dekanat@ff.bg.ac.rs

ПОТВРДА

УНИВЕРЗИТЕТ У БЕОГРАДУ
ФИЗИЧКИ ФАКУЛТЕТ
Бр. 12011
13. 04. 2022 год.
БЕОГРАД, СТУДЕНТСКИ ТРГ 12-18
П. ФАХ 44

Овим се потврђује да је др Јелена Маљковић, научни сарадник Института за физику у Београду, ментор докторских студија Јелени Вукаловић, студенту треће године докторских студија на научној области Физика атома и молекула.

Београд, 12.04.2022.



ДЕКАН ФИЗИЧКОГ ФАКУЛТЕТА

Проф. др Иван Белча

ECAMP13

13TH EUROPEAN CONFERENCE ON ATOMS,
MOLECULES AND PHOTONS

FLORENCE, ITALY

APRIL 8-12
2019



PROGRAM



COMMITTEES

AMOPD BOARD

Chair

Joachim Burgdörfer

Silvia Bergamini

Sergio Díaz-Tendero

Reinhard Dörner

Alexander Eisfeld

Jan-Petter Hansen

Anne L'Huillier

Marek Pajek

Hélène Perrin

Nina Rohringer

Igor Ryabtsev

Thomas Schlathölter

Guglielmo M. Tino

Roland Wester

LOCAL ORGANIZING COMMITTEE

Guglielmo M. Tino

Francesco S. Cataliotti

Maria Luisa Chiofalo

Marella de Angelis

Livio Gianfrani

Nicola Poli

Gabriele Rosi

Leonardo Salvi

Fiodor Sorrentino



WELCOME

We are pleased to welcoming to the 13th European Conference on Atoms Molecules and Photons (ECAMP13) in Florence!

The triennial ECAMP conference series, launched in 1981, is the major conference of the Atomic, Molecular and Optical Physics Division (AMOPD) of the European Physical Society (EPS).

The Scientific Programme covers the most recent developments in the broader field of AMO physics.

We extend our sincere appreciation and gratitude to the Chairs and all Speakers whose contributions help to make this event possible.

We are very much looking forward to this outstanding event and its unique approach to exchanging knowledge.

The Local Organizing Committee

ECAMP13

13TH EUROPEAN CONFERENCE ON ATOMS, MOLECULES AND PHOTONS

FLORENCE, ITALY

APRIL 8-12, 2019

GENERAL INFORMATION

Organizing Committee

EPS AMOPD

The Atomic, Molecular and Optical Physics Division (AMOPD) of the European Physical Society (EPS)



Organizing Secretariat



Viale Matteotti, 7 - 50121 Florence, Italy
Tel. ++39 055 50351 - Fax ++39 055 5001912
ecamp2019@oic.it - www.ecamp13.org

The Organizing Secretariat desk is open for registration and information according to the following time schedule:

Sunday, April 7	16.00-18.00
Monday, April 8	08.00-20.00
Tuesday, April 9	08.30-19.00
Wednesday, April 10	08.30-13.00
Thursday, April 11	08.30-19.00
Friday, April 12	08.30-17.30

Congress Venue

Fortezza da Basso - Cavaniglia Pavilion
Viale Strozzi 1 - 50129 Florence, Italy

App ECAMP13

A dedicated APP for ECAMP13 has been realized!
Download the app “miTalent” from App Store or Android. Insert the code: **ecamp13** and then start to use it!

Registration Fees

Registration fees (VAT included)	On site
Delegates	600,00 € (491,80 € + VAT)
Students*	320,00 € (262,30 € + VAT)

*Copy of valid Student Card must be handed at the Registration Desk

Registration is mandatory for all oral and posters presenters.

Welcome Reception & Social Dinner for Accompanying Person

The price is 70,00 € (VAT included) and includes:

- Welcome reception on April 8 at the Congress Venue
- Social dinner on April 10 2019 at Palazzo Borghese



POSTER SESSION 3

- P3.32** Symmetry breaking atomic ionization by coherent circularly polarized bichromatic radiation
E.V. Gryzlova¹, A.N. Grum-Grzhimailo¹, M.M. Popova¹, E.I. Staroselskaya¹, N. Douquet², K. Bartschat² (¹Russia, ²USA)
- P3.33** Inspecting the hydrogen migration in water using asymmetric fs laser
E. Kechaoglou, S. Kaziannis, C. Kosmidis (Greece)
- P3.34** Coherent blue light generated by four-wave mixing: interference effect and autler-townes splitting
M.P. Moreno, A.A.C. de Almeida, S.S. Vianna (Brazil)
- P3.35** Coherent population oscillations-based light storage
P. Neveu, C. Banerjee, F. Bretenaker, E. Brion, F. Goldfarb (France)
- P3.36** Phase sensitive amplification enabled by coherent population trapping
P. Neveu¹, C. Banerjee¹, J. Lugani^{1,2}, F. Bretenaker¹, E. Brion¹, F. Goldfarb¹ (¹France, ²United Kingdom)
- P3.37** Elastic electron scattering from methane molecule in the energy range from 50-300eV
J.B. Maljković¹, J. Vuković², K. Tökési³, B. Predojević², B.P. Marinković¹ (¹Serbia, ²Bosnia and Herzegovina, ³Hungary)
- P3.38** Calculation of elastic resonant electron scattering on one-electron ions
K.N. Lyashchenko¹, D.M. Vasileva¹, O.Yu. Andreev¹, A.B. Voitki² (¹Russia, ²Germany)
- P3.39** Laser-assisted (e,2e) ionization in a quasi-Sturmian-Floquet approach
S.A. Zaytsev¹, L.U. Ancarani², K.A. Kouzakov¹ (¹Russia, ²France)

Highly charged ions

- P3.40** Towards background free studies of capture reactions in a heavyion storage ring
L. Varga¹, K. Blaum¹, T. Davinson², J. Glorius¹, B. Jurado³, C. Langer¹, C. Lederer Woods², Yu.A. Litvinov¹, R. Reifarth¹, Z. Slavkovská¹, T. Stöhlker¹, P.J. Woods¹, Y.M. Xing¹ (¹Germany, ²United Kingdom, ³France)
- P3.41** Evidence of trielectronic recombination for Ar Ions in an EBIT
D.S. La Mantia^{1,2}, W. Biela¹, J.A. Tanis², A. Warczak¹ (¹Poland, ²USA)

P3.37

Elastic electron scattering from methane molecule in the energy range from 50-300eV

Jelena B. Maljković

1. *Institute of Physics Belgrade, University of Belgrade, Pregrevica 118, 11080 Belgrade, Serbia*

Jelena Vuković², **Karoly Tökési**³, **Branko Predojević**² and **Bratislav P. Marinković**¹

2. *Faculty of Science, University of Banja Luka, Mladena Stojanovića 2, 78000 Banja Luka, Republic of Srpska, Bosnia and Herzegovina*

3. *Institute for Nuclear Research, Hungarian Academy of Sciences (ATOMKI), Debrecen, Hungary*

4. *ELI-ALPS, ELI-HU Non-profit Kft., Szeged, Hungary*

Methane gas has been investigated widely in past years by electron collisions (see a comprehensive review of electron elastic cross sections [1]). We have done a combined experimental and theoretical study of the electron elastic differential cross sections from methane molecule (CH_4) in the intermediate energy range. The experimental setup based on a crossed beam technique comprising of an electron gun, a single capillary gas needle and a detection system with a channeltron was used to measure differential cross sections. The absolute scale for the cross sections is obtained by relative-flow method using argon gas as a reference [2]. For the interpretation of the measured data we applied the partial expansion method to calculate the elastic cross sections for electron scattering from methane Fig 1. shows our theoretical results of the differential elastic electron scattering from methane molecule at 100 eV.

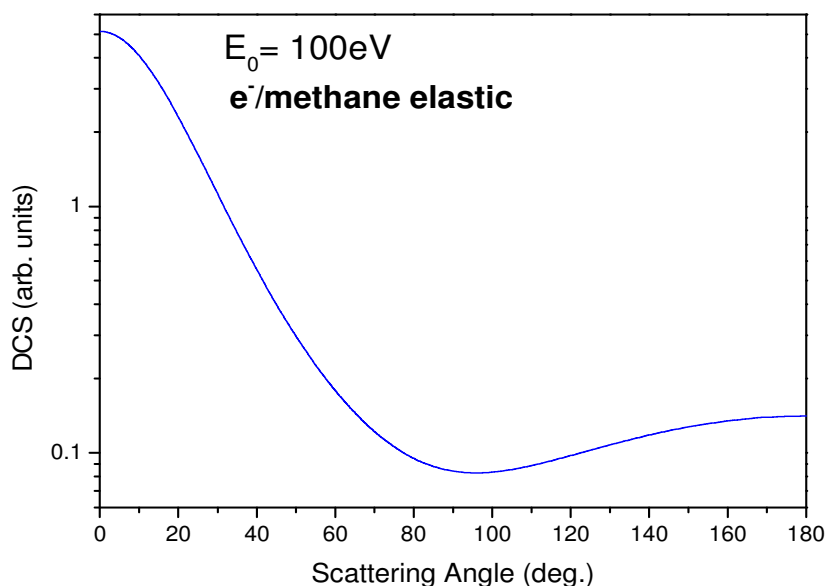

Fig. 1 Angular dependence of relative DCS for elastic electron scattering on methane molecule.

References

- [1] Bratislav P. Marinković, Vladimir A. Srećković, Veljko Vujčić, Stefan Ivanović, Nebojša Uskoković, Milutin Nešić, Ljubinko M. Ignjatović, Darko Jevremović, Milan S. Dimitrijević and Nigel J. Mason, *Databases at the Serbian Virtual Observatory for Collisional and Radiative Processes.*, *Atoms*, **7**, 11 (2019).
- [2] Miloš Lj. Ranković, Jelena B. Maljković, Karoly Tökési and Bratislav P. Marinković, *Eur. Phys. J. D.* **72**, 30 (2018).

XX International Workshop on
Low-Energy Positron and Positronium Physics

XXI International Symposium on
Electron-Molecule Collisions and Swarms

V Workshop on Non-Equilibrium Processes

18-21 July 2019, Belgrade, Serbia

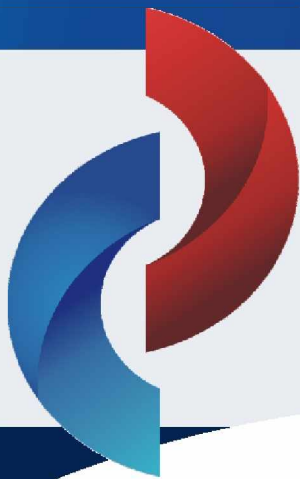

POSMOL 2019

BOOK OF ABSTRACTS

XX Међународна радионица о физици
ниско енергијских позитрона и позитронијума

XXI Међународни симпозијум о
електрон-молекулским сударима и ројевима

V Радионица о неравнотежним процесима



Serbian Academy of
Sciences and Arts



UNIVERSITY OF BELGRADE
INSTITUTE OF PHYSICS | BELGRADE

Panacomp
Wonderland Travel
Lufthansa City Center

**XX International Workshop on
Low-Energy Positron and Positronium Physics**

**XXI International Symposium on
Electron-Molecule Collisions and Swarms**

V Workshop on Non-Equilibrium Processes

POSMOL 2019

BOOK OF ABSTRACTS

Editors

David Cassidy, Michael J. Brunger,
Zoran Lj. Petrović, Saša Dujko, Bratislav P. Marinković,
Dragana Marić and Sanja Tošić

Serbian Academy
of Sciences and Art

Institute of Physics, Belgrade
University of Belgrade

Belgrade, 2019

BOOK OF ABSTRACTS of the
XX International Workshop on Low-Energy Positron and Positronium Physics
XXI International Symposium on Electron-Molecule Collisions and Swarms
V Workshop on Non-Equilibrium Processes

18-21 July 2019, Belgrade, Serbia

Editors:

David Cassidy, Michael J. Brunger,
Zoran Lj. Petrović, Saša Dujko, Bratislav P. Marinković,
Dragana Marić and Sanja Tošić

Publishers:

Serbian Academy of Sciences and Arts
Kneza Mihaila 35
11000 Belgrade, Serbia

Institute of Physics Belgrade
Pregrevica 118, P. O. Box 68
11080 Belgrade, Serbia

Computer processing:

Dragana Marić and Sanja Tošić

Printed by

Serbian Academy of Sciences and Arts
Belgrade

Number of copies

250

ISBN 978-86-7025-819-8

©2019 by the Serbian Academy of Sciences and Arts and Institute of Physics Belgrade, Serbia. All rights reserved. No part of this book may be reproduced, stored or transmitted in any manner without the written permission of the Publisher.

Absolute Differential Cross Sections for Electron Scattering from Anaesthetic Molecules

J. Vuković¹, J. B. Maljković², B. Predojević¹ and B. P. Marinković²

¹Faculty of Science, University of Banja Luka, Mladena Stojanovića 2, 78000 Banja Luka, Republic of Srpska, Bosnia and Herzegovina

²Institute of Physics Belgrade, University of Belgrade, Pregrevica 118, 11080 Belgrade, Serbia

jelenam@ipb.ac.rs

We have investigated elastic electron scattering from anaesthetic molecules, halothane and sevoflurane, in the medium energy range from 50-300 eV [1]. Experiment has been performed on the UGRA apparatus [2] settled at the Institute of Physics Belgrade. The experimental setup, based on a crossed beam technique comprising of an electron gun, a single capillary gas needle and a detection system with a channeltron, was used to measure differential cross sections. The absolute scale for the cross sections is obtained by relative-flow method using argon gas as a reference [3]. Absolute DCSs for elastic electron scattering from sevoflurane at 100 eV are shown in Fig.1.

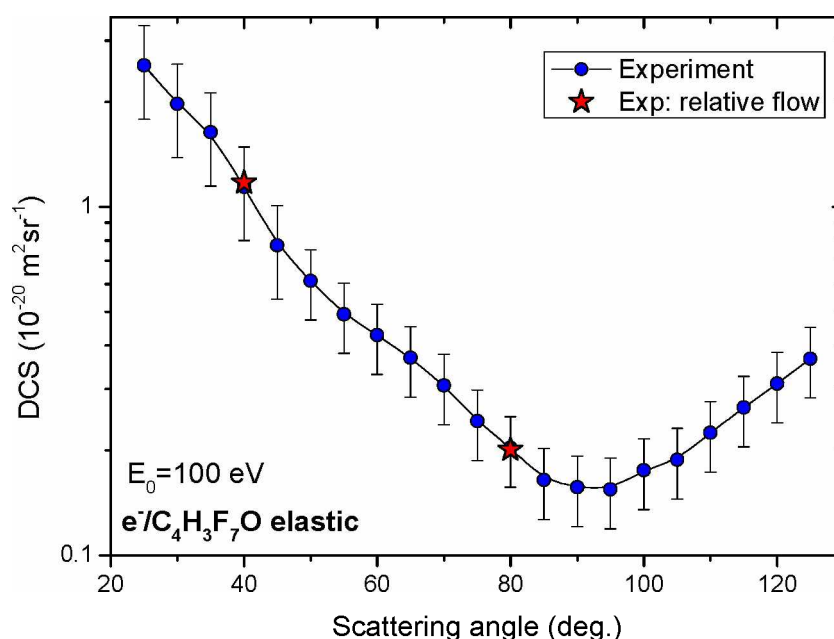

Fig.1. Angular dependence of the DCSs for elastic electron scattering from sevoflurane at 100 eV. Circles represent absolute experimental differential cross sections; stars represent absolute values obtained by relative flow method.

References

- [1] J. B. Maljković, A. R. Milosavljević, Z. Pešić, F. Blanco, G. García, D. Šević and B. P. Marinković, *Publ. Astron. Obs.*, **89**, (2010), 33.
- [2] A. R. Milosavljević, S. Mandžukov, D. Šević, I. Čadež, and B. P. Marinković, *J. Phys. B*, **39**, (2006), 609.
- [3] M. Lj. Ranković, J. B. Maljković, K. Tökési and B. P. Marinković, *Eur. Phys. J. D* **72**, (2018), 30.

CIP- Каталогизација у публикацији
Народна библиотека Србије

539.124.6(048)

INTERNATIONAL Workshop on Low-Energy
Positron and Positronium Physics (20 ; 2019 ; Beograd)
POSMOL 2019 : book of abstracts / XX International
Workshop on Low-Energy Positron and Positronium
Physics, XXI International Symposium on Electron-
Molecule Collisions and Swarms [and] V Workshop on
Non-Equilibrium Proces, 18-21 July 2019, Belgrade ;
editors David Cassidy ... [et al.]. - Belgrade : SASA :
Institute of Physics, 2019 (Belgrade : SASA). - 163 str. ;
30 cm

Tiraž 250. - Registar.

ISBN 978-86-7025-819-8 (SASA)

1. International Symposium on Electron-Molecule
Collisions and Swarms (21 ; 2019 ; Beograd)
2. Workshop on Non-Equilibrium Processes (5 ; 2019 ;
Beograd)

а) Позитрони – Апстракти б) Елементарне честице-
Интеракција- Апстракти

COBISS.SR-ID 277345036



Ministry of Education,
Science and Technological Development of the
Republic of Serbia



ISBN 978-86-7025-819-8



ICPEAC DEAUVILLE 2019



XXXI INTERNATIONAL CONFERENCE ON PHOTONIC, ELECTRONIC AND ATOMIC COLLISIONS

BOOK OF ABSTRACTS

JULY 23-30, 2019
DEAUVILLE, FRANCE

www.icpeac2019.fr





BOOK OF ABSTRACTS

SPECIAL REPORTS AND POSTERS

XXXI INTERNATIONAL CONFERENCE ON PHOTONIC,
ELECTRONIC, AND ATOMIC COLLISIONS

23 JULY – 30 JULY 2019, DEAUVILLE, FRANCE

*Edited by H. Bachau, R. Brédy,
O. Dulieu, E. Lamour, F. Penent,
C. Prigent, M. Trassinelli, D. Vernhet*

Integral cross sections for elastic electron scattering by methane molecule

J B Maljković^{1*}, J Vuković², K Tökési^{3,4}, B Predojević² and B P Marinković^{1†}

¹Institute of Physics Belgrade, University of Belgrade, Pregrevica 118, 11080 Belgrade, Serbia

²Faculty of Science, University of Banja Luka, Mladena Stojanovića 2, 78000 Banja Luka, Republic of Srpska, Bosnia and Herzegovina

³Institute for Nuclear Research, Hungarian Academy of Sciences (ATOMKI), Debrecen, Hungary

⁴ELI-ALPS, ELI-HU Non-profit Kft., Szeged, Hungary

Synopsis We have performed a combined experimental and theoretical study of electron elastic differential and integral cross sections from methane molecule (CH₄) in the intermediate energy range. Data have been compared with available data sets in the literature as well as with recommended data set [Song *et al J. Phys. Chem. Ref. Data* **44** 023101 (2015)].

Methane gas has been investigated widely in past years by electron collisions [1,2]. We measured electron elastic differential cross sections (DCSs) for methane molecule (CH₄) in the energy range from 50 eV to 300 eV and angular range from 20° to 130°. DCSs were then extrapolated to zero and 180° and integrated in order to obtain the integral cross sections. The experimental setup based on a crossed beam technique comprising of an electron gun, a single capillary gas needle and a detection system with a channeltron was used to measure differential cross sections.

The absolute scale for the cross sections is obtained by relative-flow method using argon gas as a reference [3]. For the interpretation of the measured data we applied the partial expansion method to calculate the elastic cross sections for electron scattering from methane.

Here we present our data point at 50 eV and we find it in an excellent agreement with the recommended set of data [1]. At the conference we will present our data points in a full scale of electron impact energies, from 50 to 300 eV in steps of 50 eV and calculated ICS curves obtained based on IAM method and screening correction factors.

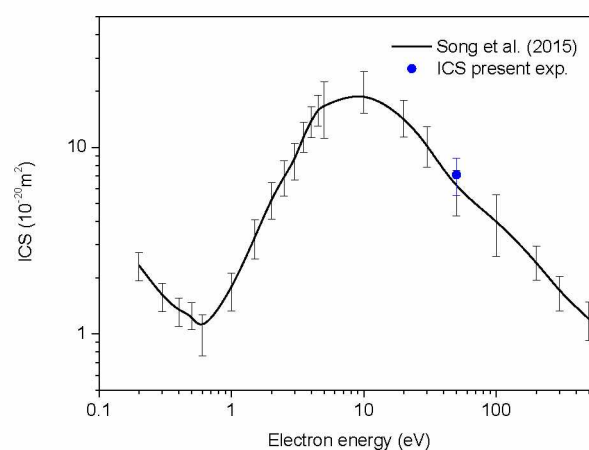

Figure 1. Energy dependence of integral cross sections for elastic electron scattering by methane molecule.

This work has been supported by the MESTD Grant #OI 171020. BPM acknowledges the grant of VAMDC consortium under Support Actions" Funding Scheme of The Seventh Framework Program. One of us KT was also supported by the National Research, Development and Innovation Office (NKFIH) Grant KH126886, and by the European COST Action CA15107 (MultiComp).

References

- [1] Song M-Y *et al* 2015 *J. Phys. Chem. Ref. Data* **44** 023101
- [2] Marinković B P *et al* 2019 *Atoms* **7** 11
- [3] Ranković M Lj *et al* 2018 *Eur. Phys. J D* **72** 30

* E-mail: jelena.maljkovic@ipb.ac.rs

† E-mail: bratislav.marinkovic@ipb.ac.rs

LOCAL ORGANIZING COMMITTEE

CHAIR

Dominique Vernhet (INSP - Paris)

CO-CHAIRS

Lamri Adoui (CIMAP - Caen)

Danielle Dowek (ISMO - Orsay)

Olivier Dulieu (LAC - Orsay)

Emily Lamour (INSP - Paris)



CELIA-Bordeaux

H. Bachau
V. Blanchet
F. Catoire
B. Fabre
B. Pons
A. Sopena

CIMAP-Caen

A. Domaracka
J. Douady
P. Rousseau

ILM-Lyon

C. Bordas
R. Brédy
F. Lépine

INSP-Paris

C. Prigent
S. Steydli
M. Trassinelli

IPCMS-Strasbourg

P.-A. Hervieux

IPN-Orsay

M. Chabot

LCPMR-Paris

T. Marchenko
F. Penet

LOMC- Le Havre

I. Schneider

LPCT-Metz

U. Ancarani

LPT-Toulouse

P. M. Dinh

PIIM-Marseille

S. Ferri

www.icpeac2019.fr



Subject New Nomination as MC Substitute [CA18212 RS]
From COST Association Notification <noreply@cost.eu>
To <jelenam@ipb.ac.rs>
Date 2019-06-25 11:37



Dear Dr Jelena Maljkovic,

This message is to inform you that you have been nominated as MC Substitute [CA18212 RS] on 2019-06-25 11:36:27

You can find an overview of your roles at: <https://e-services.cost.eu>

Best regards,

COST Association
Avenue Louise 149
1050 Brussels | Belgium
www.cost.eu

Best regards,

COST Association

COST Association | Avenue Louise 149
1050 Brussels | Belgium
Tel: +32 2 533 38 00
helpdesk@cost.eu | <https://www.cost.eu>

E-101 — Mail generated by e-COST on 25 June 2019 at 11:36:27

PAPER • OPEN ACCESS

Integral cross sections for elastic electron scattering by methane molecule

To cite this article: J B Maljkovi *et al* 2020 *J. Phys.: Conf. Ser.* **1412** 182012

View the [article online](#) for updates and enhancements.

You may also like

- [Innovative Ideas in Science 2016](#)
- [Separation of electronic states for small molecular ions by the mobility measurements in cooled He gas](#)
T Yamazaki, K Mori and H Tanuma
- [Electron elastic scattering from Ho, Er, Tm, Yb, Lu and Hf atoms](#)
Z Felfli and A Z Msezane



The Electrochemical Society
Advancing solid state & electrochemical science & technology

242nd ECS Meeting

Oct 9 – 13, 2022 • Atlanta, GA, US

Extended abstract submission deadline: April 22, 2022

Connect. Engage. Champion. Empower. Accelerate.

MOVE SCIENCE FORWARD



Submit your abstract



Integral cross sections for elastic electron scattering by methane molecule

J B Maljković^{1*}, J Vuković², K Tökési^{3,4}, B Predojević² and B P Marinković^{1†}

¹Institute of Physics Belgrade, University of Belgrade, Pregrevica 118, 11080 Belgrade, Serbia

²Faculty of Science, University of Banja Luka, Mladena Stojanovića 2, 78000 Banja Luka, Republic of Srpska, Bosnia and Herzegovina

³Institute for Nuclear Research, Hungarian Academy of Sciences (ATOMKI), Debrecen, Hungary

⁴ELI-ALPS, ELI-HU Non-profit Kft., Szeged, Hungary

Synopsis We have performed a combined experimental and theoretical study of electron elastic differential and integral cross sections from methane molecule (CH₄) in the intermediate energy range. Data have been compared with available data sets in the literature as well as with recommended data set [Song *et al J. Phys. Chem. Ref. Data* **44** 023101 (2015)].

Methane gas has been investigated widely in past years by electron collisions [1,2]. We measured electron elastic differential cross sections (DCSs) for methane molecule (CH₄) in the energy range from 50 eV to 300 eV and angular range from 20° to 130°. DCSs were then extrapolated to zero and 180° and integrated in order to obtain the integral cross sections. The experimental setup based on a crossed beam technique comprising of an electron gun, a single capillary gas needle and a detection system with a channeltron was used to measure differential cross sections.

The absolute scale for the cross sections is obtained by relative-flow method using argon gas as a reference [3]. For the interpretation of the measured data we applied the partial expansion method to calculate the elastic cross sections for electron scattering from methane.

Here we present our data point at 50 eV and we find it in an excellent agreement with the recommended set of data [1]. At the conference we will present our data points in a full scale of electron impact energies, from 50 to 300 eV in steps of 50 eV and calculated ICS curves obtained based on IAM method and screening correction factors.

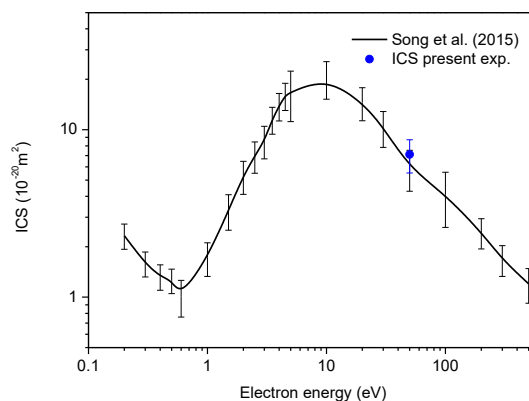

Figure 1. Energy dependence of integral cross sections for elastic electron scattering by methane molecule.

This work has been supported by the MESTD Grant #OI 171020. BPM acknowledges the grant of VAMDC consortium under Support Actions" Funding Scheme of The Seventh Framework Program. One of us KT was also supported by the National Research, Development and Innovation Office (NKFIH) Grant KH126886, and by the European COST Action CA15107 (MultiComp).

References

- [1] Song M-Y *et al* 2015 *J. Phys. Chem. Ref. Data* **44** 023101
- [2] Marinković B P *et al* 2019 *Atoms* **7** 11
- [3] Ranković M Lj *et al* 2018 *Eur. Phys. J D* **72** 30

* E-mail: jelena.maljkovic@ipb.ac.rs

† E-mail: bratislav.marinkovic@ipb.ac.rs





Република Србија

Министарство просвете, науке и технолошког развоја

Годишњи извештај о раду на пројекту у 2019. години

<i>ПРОГРАМ</i>	<i>ОСНОВНА ИСТРАЖИВАЊА</i>
----------------	----------------------------

<i>ОБЛАСТ</i>	<i>Физика</i>
---------------	---------------

<i>Назив пројекта</i>	<i>Физика судара и фотопроееса у атомским, (био)молекулским и нанодимензионим системима</i>
-----------------------	---

<i>Евиденциони број</i>	<i>171020</i>
-------------------------	---------------

Годишњи извештај о раду на пројекту у 2019. години

Име: Братислав
Презиме: Маринковић
Број телефона: 316-0882
E-mail адреса: bratislav.marinkovic@ipb.ac.rs
Радна организација: 200024-Универзитет у Београду, Институт за физику
Град: Belgrade
Број поште: 11080
Страна 1 - Општи подаци
Програм ОСНОВНА ИСТРАЖИВАЊА
Област Физика
Број пројекта 171020
Назив Пројекта Физика судара и фотопроцеса у атомским, (био)молекулским и нанодимензионим системима
Тип пројекта Б-Експериментални
Страна 2 - Опис истраживања
<p>Циљеви истраживања (према достављеном плану истраживања) остварени у 2019. години имајући у виду значај, квалитет и ниво остварених резултата. ТЕМА 1. ИНТЕРАКЦИЈЕ ЕЛЕКТРОНА, ЈОНА И ФОТОНА СА АТОМИМА И (БИО)МОЛЕКУЛИМА (КОНСТИТУЕНТИМА ИЛИ АНАЛОГОНИМА ДНК МОЛЕКУЛА) РАДИ БОЉЕГ РАЗУМЕВАЊА ПРОЦЕСА РАДИЈАЦИОНОГ ОПШТЕЊЕЊА. Задатак 1.1 а) На апаратури ОНРНА (Omicron High Resolution Hemispherical Analyser) измерени су спектри избачених електрона аутојонизационих стања и Coster-Kronig прелаза у атому Ar, а публиковани у међународном часопису [P18. Energy analysis of ejected electrons in the region of the Ar L1–L2,3M Coster-Kronig transitions (25-56 eV) induced by electron impact, J. Electron Spectrosc. 237, 146898 (2019) 6pp]. б) На апаратури ESMA завршена су и публикована мерења диференцијалних пресека за еластично расејање електрона при упадним енергијама електрона од 10-100 eV на атому Zn [P12. Experimental and theoretical cross sections for elastic electron scattering from zin, Phys. Rev. A 99, 062702 (2019) 10pp]. Задатак 1.2 (руководилац задатка др Јелена Маљковић): а) Извршена су мерења еластичног расејања електрона на молекулу три-етил-фосфату. Резултати су обрађени и публиковани [P03. Elastic electron scattering cross sections for triethyl phosphate molecule at intermediate electron energies from 50 to 250 eV, Eur. Phys. J.D 73, 27 (2019) 5pp]. б) Прелиминарна мерења еластичног расејања електрона на молекулу метана су представљена на престижним међународним конференцијама ЕСАМР13 и XXXI ICPEAC [CI08. Integral cross sections for elastic electron scattering by methane molecule; CI01. Elastic electron scattering from methane molecule in the energy range from 50-300 eV] в) У оквиру пост доктората у сарадњи са колегама из Прага обављен је рад о дисоцијативној јонизацији молекула флуоронитрила [O02 Phys. Chem. Chem. Phys. 21(30) 16451-16458 (2019)]. Задатак 1.3 Изучавана је теорија судара топких честица: а) Публикован је рад у коме је примењена динамичка адијабатска теорија судара у опису атома водоника у s-стању [P05. Classical representation for hydrogen atom in s-states, Quantum Stud.: Math. Found. 6(2) 225-233 (2019)]. б) (руководилац задатка др Ненад Милојевић): Истраживан је парцијални и укупни пресек за захват електрона из K-љуске вишеелектронских мета од стране потпуно огољених пројектила. Написан је и публикован прегледни рад на ову тему у реномираном часопису. [P15. State-selective and total cross sections for electron capture from the K-shell of multi-electron atoms by fully stripped projectiles. At. Data Nucl. Data Tables, (2019) 18pp]. ТЕМА 2. ИНТЕРАКЦИЈЕ СА ПОВРШИНАМА НА НАНОМЕТАРСКОЈ СКАЛИ (НАНОКАПИЛАРЕ, НАНОТАЧКЕ) КОЈЕ ВОДЕ ФУНКЦИОНАЛИЗАЦИЈИ МАТЕРИЈАЛА ИЛИ МОДИФИКАЦИЈИ НАНОФИЛМОВА. Задатак 2.1: (руководилац задатка др Милош Ранковић): Завршена тематика. Задатак 2.2 а) (руководилац задатка др Маја Рабасовић): Извршена су мерења оптичких особина прашкастих нано материјала (Sr2CeO4:Eu; GdVO4:Sm; Gd2Zr2O7:Eu; CaWO4:Nd), као и апконверзионог материјала (Gd2O3:Er, Yb). Могућности примене материјала YVO4:Eu3+ за мерења промене температуре су публиковани [P22. J. Phys. D: Appl. Phys. 53, 015106, 10pp, online 1st Oct. 2019]. Резултати анализе и карактеризације материјала CdSe/ZnS-PMMA публиковани су у раду [P17. Optical properties CaWO4:Nd3+/PMMA composite layered structures, Opt. Mater. 96, 109361 (2019) 8pp]. Оптичке особине материјала CaWO4:Nd су представљене у раду [P11. Optical properties and fluorescence of quantum dots CdSe/ZnS-PMMA composite films with interface modifications, Opt. Mater. 92, 405-410 (2019)]. б) Настављено је изучавање ласерски индукованог пробоја и посматрани различити временски размапи узорковања [P01. Laser-Induced Plasma Measurements Using Nd:YAG Laser and Streak Camera: Timing Considerations, Atoms, 7(1), 6 (2019) 12pp]. в) Испитивана је локализација електрона у двоелектронским квантним тачкама у зависности од јачине спољашњег магнетног поља и веза са квантном преплетеношћу најнижих стања и публикован је рад. [P19. Effect of the magnetic field on electron density distributions in two-electron quantum dots. J. Phys. A. Math. Theo. 52, 435303 (2019) 21pp]. 2.3 Настављена је обрада резултата TiO2 мемристора добијених FEBID техником. ТЕМА 3. ФОТОПРОЦЕСИ ВЕЗАНИ ЗА ИНТЕРАКЦИЈЕ ЛАСЕРСКОГ И СИНХРОТРОНСКОГ ЗРАЧЕЊА СА АТОМИМА, ЈОНИМА И (БИО)МОЛЕКУЛИМА. Задатак 3.1 а) Интеракција ласерског зрачења са биомолекулима (руководилац задатка др Маја Рабасовић): Настављено је изучавање временски разложених луминесцентних спектра алкалоида биљке руса [C110. Nonlinear microscopy and time resolved fluorescence spectroscopy of Chelidonium majus L. Proc. PHOTONICA2019]. б) Интеракција синхротронског зрачења са (био)молекулима (руководилац задатка др Сања Топић): Проучавани су могући механизми фрагментације молекула као директне последице апсорпције X зрачења помоћу подесивог синхротронског зрачења у комбинацији са различитим експерименталним техникама (PES, XPS, NEXAFS, PEPCO, PIPICO, масена спектрометрија) на различитим молекулима: i) нитроимидазолима [P10. Radiation Damage Mechanisms of Chemotherapeutically Active Nitroimidazole Derived Compounds, Front. Chem. 7, 329 (2019) 14pp: P06. Core shell investigation of 2-nitroimidazole, Front. Chem. 7, 151 (2019) 13pp]; ii) Титанијум-изо-пропоксид (органометалик, прекурсор за хемијску депозицију и ФЕБИД технику високе резолуције која омогућава стварање и уређивање наноструктурних материјала) [C113. Photo-induced fragmentation of the titanium (IV) iso-propoxide molecule, VEIT 2019: C112. Inner-shell spectroscopy of titanium (IV) iso-propoxide, PHOTONICA2019]. Ова истраживања су представљена и на уводном предавању у оквиру прве европске радионице корисника синхротрона одржане у Београду ESUO Organization [T02. Core Shell Investigation and Radiation Damage Mechanisms of Nitroimidazole Compounds studies at the Gasphase Beamline @ Elettra, Photonica 2019 and 1st ESUO Regional Meeting, Belgrade, 28.08.2019] Задатак 3.2 (руководилац задатка др Предраг Коларж): Истражена ефективна доза озрачености појединих делова Балкана [O01. Effective Doses Estimated from the Results of Direct Radon and Thoron Progeny Sensors (DRPS/DTPS), Exposed in Selected Regions of Balkans, Radiation</p>

Subject Fwd: MD-GAS COST Action: invited talk

From Jelena Maljkovic <jelenam@ipb.ac.rs>

To Jelena Maljkovic <jelenam@ipb.ac.rs>

Date 2022-04-11 13:48

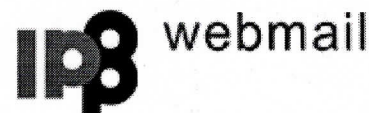

----- Original Message -----

Subject: MD-GAS COST Action: invited talk

Date: 2019-12-18 11:52

From: Alicja DOMARACKA <domaracka@ganil.fr>

To: <jelenam@ipb.ac.rs>

Dear Jelena Maljkovic,

On behalf of the Scientific Organizing Committee I would like to invite you to give a talk with the tentative title Elastic electron scattering processes at the first General Meeting of the COST Action: MD-GAS (Molecular Dynamics in the GAS-phase). The meeting will be held at the GANIL facility in Caen, France, February 18-21, 2020. See <https://www.cost.eu/actions/CA18212/#tabs|Name:overview> [1] for more information about this new COST Action, which started on November 12, 2019. Invited talks will be 25 min+5 min for questions.

Note that there is no registration fee. Further information will soon be available on the meeting website: <https://md-gas.sciencesconf.org>

Given the very short time to meeting, we kindly ask for your definite decision within 7 calendar days.

In case of a positive response, please also provide the title of your talk.

We look forward to hearing from you soon.

Best regards,

Alicja Domaracka,

on behalf of the Scientific Organizing Committee

--

Alicja Domaracka (CNRS)

CIMAP - Centre de Recherche sur les Ions, les Matériaux et la Photonique

UMR 6252 (CEA - CNRS - ENSICAEN - Université de Caen Normandie)

CIMAP - GANIL Bd H. Becquerel - BP 5133 - 14070 CAEN Cedex 5 FRANCE

Tél : +33 (0) 2 31 45 45 03

Fax : +33 (0) 2 31 45 47 14

<http://cimap.ensicaen.fr>

Préservez notre environnement, n'imprimez ce mail que si nécessaire.

Preserve our environment, print this email only if necessary.

Links:

[1] <https://www.cost.eu/actions/CA18212/#tabs|Name:overview>

--

Institute of Physics Belgrade

Pregrevica 118, 11080 Belgrade, Serbia

<http://www.ipb.ac.rs/>

Subject COST Action CA20129: Update of Working Group Assignment
From COST Association Notification <noreply@cost.eu>
To Jelena Maljkovic <jelenam@ipb.ac.rs>
Date 2022-02-10 16:11



Dear Dr Jelena Maljkovic,

This is to inform you that your Working Group assignment has been updated. You are currently assigned to the following Working Groups of COST Action CA20129:

WG1: 1. Irradiation- and chemistry-driven multiscale phenomena
WG4: 4. Training, dissemination and outreach

If you need further information, please contact the Action.

Best regards,

COST Association

COST Association | Avenue du Boulevard-Bolwerklaan 21
1210 Brussels | Belgium
Tel: +32 2 533 38 00
helpdesk@cost.eu | <https://www.cost.eu>

WG-007 — Mail generated by e-COST on 10 February 2022 at 16:11:10

НАУЧНОМ ВЕЋУ ИНСТИТУТА ЗА ФИЗИКУ

Предмет:

Захтев за покретање поступка за избор у звање научног сарадника
др Јелена Маљковић

Молим Научно веће Института за физику да у складу са Правилником о поступку и начину вредновања и квантитативном исказивању научноистраживачких резултата истраживача, покрене поступак за мој избор у звање научног сарадника.

У Београду, 24.05.2013. године

Jelena Maljković

8. Biografija

Jelena (Božidara) Maljković je rođena u Travniku (Bosna i Hercegovina) 24. aprila 1977. godine. Fizički fakultet – smer Teorijska i eksperimentalna fizika je završila 2006. godine na Univerzitetu u Beogradu sa srednjom ocenom 8,82. Master studije je upisala 2006. godine na Fizičkom fakultetu Univerziteta u Beogradu i završila 2007. godine sa prosečnom ocenom 10,00. Doktorske studije je upisala 2007. godine na Fizičkom fakultetu Univerziteta u Beogradu – smer Eksperimentalna fizika atoma i molekula i završila sa srednjom ocenom 10,00.

Jelena Maljković je dobitnik Norveške stipendije 2001. godine. U radnom odnosu na Institutu za fiziku Univerziteta u Beogradu je od juna 2008. godine u zvanju istraživač saradnik. Učestvovala je takođe na nekoliko bilateralnih naučnih projekata (Srbija-Slovenija 2008-2009; Srbija-Slovačka 2010-2011; Srbija-Francuska 2012-2013). U okviru ovih projekata, Jelena Maljković je značajno proširila svoje znanje i iskustvo tokom naučnih poseta Institutu „Jožef Stefan“ u Ljubljani, „Comenius“ Univerzitetu u Bratislavi i SOLEIL sinhrotronu pored Pariza.

МИШЉЕЊЕ РУКОВОДИОЦА ПРОЈЕКТА СА ПРЕДЛОГОМ ЧЛАНОВА КОМИСИЈЕ ЗА ПИСАЊЕ ИЗВЕШТАЈА

Кандидаткиња др Јелена Маљковић испуњава све услове предвиђене Правилником којим се регулишу стицања научних звања Републике Србије за избор у звање научног сарадника те сматрам да Научно веће Института за физику Универзитета у Београду треба да покрене иницијативу за њен избор у ово звање.

Кандидаткиња је учествовала у претходним научно-истраживачким пројектима Министарства за науку и технолошки развој а сада Министарству за просвету, науку и технолошки развој Републике Србије и на сваком је показала запажене резултате. Јелена Маљковић је докторску дисертацију одбранила на Физичком факултету Универзитета у Београду дана 14.05.2013. под менторством др Александра Милосављевића.

У периоду до одбране докторске дисертације публиковала је 7 радова у међународним часописима, 9 саопштења на међународним и једно на националним скуповима. Радови су до сада цитирани 29 пута без аутоцитата (Web of Knowledge, 23.05.2013).

Предлог чланова Комисије за писање извештаја:

1. др Александар Милосављевић, виши н.сарадник , 1. референт
2. др Братислав Маринковић, н.саветник
3. др Горан Попарић, ванредни професор Унив. у Београду

Руководилац пројекта ОИ 171020

Др Братислав Маринковић,
научни саветник

СПИСАК НАУЧНИХ РАДОВА

МОНОГРАФИЈЕ, МОНОГРАФСКЕ СТУДИЈЕ, ТЕМАТСКИ ЗБОРНИЦИ, ЛЕКСИКОГРАФСКЕ И КАРТОГРАФСКЕ ПУБЛИКАЦИЈЕ МЕЂУНАРОДНОГ ЗНАЧАЈА

M14

1. Cross section data for electron collisions in plasma physics
B. P. Marinković, V. Pejčev, D. M. Filipović, D. Šević, A. R. Milosavljević, S. Milisavljević, M. S. Rabasović, D. Pavlović and J. B. Maljković
Journal of Physics: Conference Series, **86**, 012006 (2007).

РАДОВИ ОБЈАВЉЕНИ У НАУЧНИМ ЧАСОПИСИМА МЕЂУНАРОДНОГ ЗНАЧАЈА

M 21

- P1. M Danko, J Orszagh, M Durian, J Kočišek, M Daxner, S Zöttl,
J B Maljković, J Fedor, P Scheier, S Denifl and Š Matejčik
“Electron impact excitation of methane:determination of appearance energies for
dissociation products”
J. Phys. B: At. Mol. Opt. Phys **46** 045203 (2013)
[DOI: 10.1088/0953-4075/46/4/045203](https://doi.org/10.1088/0953-4075/46/4/045203)
- P2. J. B. Maljković, F. Blanco, R. Čurik, G. García, B. P. Marinković, and A. R. Milosavljević,
“Absolute cross sections for electron scattering from furan”,
J. Phys. Chem. **137** 064312 (2012) [10 pages].
<http://link.aip.org/link/?JCP/137/064312>
[DOI: 10.1063/1.4742759](https://doi.org/10.1063/1.4742759)
- P3. J. B. Maljković, F. Blanco, G. García, B. P. Marinković, and A. R. Milosavljević,
“Absolute cross sections for elastic electron scattering from methylformamide”,
Physical Review A **85**, 042723 (2012) [8 pages].
<http://link.aps.org/doi/10.1103/PhysRevA.85.042723>
[DOI: 10.1103/PhysRevA.85.042723](https://doi.org/10.1103/PhysRevA.85.042723)
- P4. J. B. Maljković, A. R. Milosavljević, F. Blanco, D. Šević, G. García, and B. P. Marinković,
“Absolute differential cross sections for elastic scattering of electrons from pyrimidine”,
Phys. Rev. A **79**, 052706 (2009) [7 pages].

<http://link.aps.org/doi/10.1103/PhysRevA.79.052706>
DOI: [10.1103/PhysRevA.79.052706](https://doi.org/10.1103/PhysRevA.79.052706)

M 22

P1. J. B. Maljković, F. Blanco, G. García, B. P. Marinković, and A. R. Milosavljević,
“Elastic electron scattering from formamide molecule”,
Nucl.Instrum. Meth. B. **279** 124-127 (2012).
Special issue: Proceedings of the *Fifth International Conference on Elementary Processes in Atomic Systems*, Belgrade, Serbia, 21-25 June 2011, Edited by Bratislav Marinković and Károly Tőkési.
[doi:10.1016/j.nimb.2011.10.029](https://doi.org/10.1016/j.nimb.2011.10.029)

M 23

P1. A. R. Milosavljević, F. Blanco, J. B. Maljković, D. Šević, G. García, and B. P. Marinković,
“Absolute cross sections for elastic electron scattering from 3-hydroxytetrahydrofuran”,
New J. Phys. **10** 103005 (2008) [19 pages].
[doi: 10.1088/1367-2630/10/10/103005](https://doi.org/10.1088/1367-2630/10/10/103005)
P7. B. P. Marinković, A. R. Milosavljević, J. B. Maljković, D. Šević, B. A. Petruševski, D. Pavlović, D. M. Filipović, M. Terzić and V. Pejčev,
“Optical and Electron Spectrometry of Molecules of Biological Interest”,
Acta Physica Polonica A **112**(5) 1143-1148 (2007).
<http://przyrbwn.icm.edu.pl/APP/ABSTR/112/a112-5-68.html>
<http://przyrbwn.icm.edu.pl/APP/PDF/112/a112z568.pdf>
Proceedings of the International School and Conference on Optics and Optical Materials, ISCOM07, September 3-7, 2007, Belgrade, Serbia. ISSN: 0001-673X

ЗБОРНИЦИ СА МЕЂУНАРОДНИХ НАУЧНИХ СКУПОВА

M32

1 **A. R. Milosavljević**, F. Blanco, J. B. Maljković, G. García, B. P. Marinković,
“Absolute differential cross sections for electron scattering from building blocks of biopolymers”,
Proc. 5th Conference on Elementary Processes in Atomic Systems (CEPAS2011) and the 2nd National Conference on Electronic, Atomic, Molecular and Photonic Physics (CEAMPP2011),
21st – 25th June 2011, Belgrade, Serbia, Contributed Papers & Abstracts of Invited Lectures,
Editors: Aleksandar R. Milosavljević, Saša Dujko and Bratislav P. Marinković, Abstract of
Invited Topical Lecture, p.28.
ISBN: 978-86-82441-32-8

Acknowledgements: MES Serbia (# 171020), Spanish MCIP (#FIS2009-10245), COST ECCL and COST nano-IBCT.

<http://www.cepas2011.ipb.ac.rs//>

M 33

1 Aleksandar R. Milosavljević, Jelena B. Maljković, Dragutin Šević, Iztok Čadež and Bratislav P. Marinković,

“Measurement of kinetic energy distribution of positive ions from electron induced dissociation of pyrimidine molecule”,

Proc. 25th Summer School and International Symposium on Physics of Ionized Gases SPIG, 30th Aug – 4th Sept. 2010, Donji Milanovac, Serbia, Book of Contributed Papers and Abstracts of Invited Lectures, Topical Invited Lectures and Progress Reports, editors: L. Č. Popović and M. M. Kuraica, ISBN 978-86-80019-37-6,

Publ. Astron. Obs. Belgrade No. 89, July 2010, ISSN: 0373-3742 pp. 37 – 40.

Acknowledgements: grant 141011 as well as the project of bilateral scientific collaboration between Serbia and Slovenia 2008-2009 (“Electron induced fragmentation of organic molecules and small hydrocarbons”).

2. Jelena B. Maljković, Aleksandar R. Milosavljević, Zoran Pešić, F. Blanco, G. García, Dragutin Šević and Bratislav P. Marinković,

“Absolute differential cross section for elastic electron scattering from halothane at 100eV

Proc. 25th Summer School and International Symposium on Physics of Ionized Gases SPIG, 30th Aug – 4th Sept. 2010, Donji Milanovac, Serbia, Book of Contributed Papers and Abstracts of Invited Lectures, Topical Invited Lectures and Progress Reports, editors: L. Č. Popović and M. M. Kuraica, ISBN 978-86-80019-37-6,

Publ. Astron. Obs. Belgrade No. 89, July 2010, ISSN: 0373-3742 pp. 33 – 36.

Acknowledgements: grant 141011 as well as EU/ESF COST CM0601 “Electron Controlled Chemical Lithography” (ECCL), and MP1002 “Nano-scale insights in ion beam cancer therapy” (Nano-IBCT)

3. A. R. Milosavljević, F. Canon, J. B. Maljković, L. Nahon and A. Giuliani,

“Photodissociation of pure and nanosolvated protonated leucineenkephalin peptide”,

Proc. 26th Summer School and International Symposium on Physics of Ionized Gases SPIG, 27th – 30th Aug. 2012, Zrenjanin, Serbia, Book of Contributed Papers & Abstracts of Invited Lectures and Progress Reports, editors: M. Kuraica and Z. Mijatović, ISBN 978-86-7031-242-5(print) and 978-86-7031-244-9(e-book), *Contributed Paper*, pp.55 – 58.

<http://spig2012.pmf.uns.ac.rs/>

M 34

1. A. R. Milosavljević, J. B. Maljković, D. Šević and B. P. Marinković,

“Electron interaction with biologically relevant molecules in gaseous phase”,

Research Conference, ESF-FWF Conference in Partnership with LFUI, “*Chemical Control with Electrons and Photons*”, Chairs: P. Swiderek and N. J. Mason, 22-27 November, 2008, Obergurgl, Austria, Poster Abstracts 30.

<http://www.esf.org/conferences/08261>

2. J. Maljković, A. R. Milosavljević, D. Šević and B. P. Marinković,

“Relative angle-differential cross sections for elastic electron scattering from pyrimidine”,

Proc. 24th Symposium on Physics of Ionized Gases – SPIG’2008, Contributed Papers and Abstracts of Invited Lectures, Topical Invited Lectures and Progress Reports, 25 – 29 August

2008, Novi Sad, Serbia, Eds. G. Malović, L. Č. Popović and M. S. Dimitrijević (Belgrade, Astronomical Observatory) Publ. Astron. Obs. Belgrade, No. 84, July 2008, Contributed Paper, pp. 45 – 48.

3. A. R. Milosavljević, F. Blanco, J. B. Maljković, G. García, B. P. Marinković,

“Absolute cross sections for electron interaction with molecules representing sub-units of biopolymers”,

The 1st Nano-IBCT Conference on Radiation damage of biomolecular systems: Nano-scale insights into Ion Beam Cancer Therapy, 2 - 6 Oct. 2011, Caen, France, Poster presentation

<http://nano-ibct.sciencesconf.org/>

4. J. B. Maljković, F. Blanco, G. García, B. P. Marinković, A. R. Milosavljević,

“Elastic electron scattering from formamide molecule”,

Proc. 5th Conference on Elementary Processes in Atomic Systems (CEPAS2011) and the 2nd National Conference on Electronic, Atomic, Molecular and Photonic Physics (CEAMPP2011), 21st – 25th June 2011, Belgrade, Serbia, Contributed Papers & Abstracts of Invited Lectures, Editors: Aleksandar R. Milosavljević, Saša Dujko and Bratislav P. Marinković, Abstract of Poster Contributions p.69.

ISBN: 978-86-82441-32-8

Acknowledgements: MES Serbia (# 171020), Spanish MCIP (#FIS2009-10245), COST ECCL and COST nano-IBCT.

<http://www.cepas2011.ipb.ac.rs/>

6. J. B. Maljković, F. Blanco, G. García, B. P. Marinković and A. R. Milosavljević,

“Relative differential cross sections for elastic electron scattering by furan”,

Proc. XXI European Conf. on the Atomic and Molecular Physics of Ionized Gases (XXI ESCAMPIG), 10 – 14 July 2012, Viana do Castelo, Portugal, European Conference Abstracts Vol. 36A Editors: P.G.C. Almeida, L. L. Alves and Vasco Guerra, Poster contribution P2.1.4.

ISBN: 2-914771-74-6

<http://escampig2012.ist.utl.pt/>

Acknowledgements: MES Serbia (# 171020), Spanish Ministerio de Ciencia e Innovación (# FIS2009-10245), and the COST Action MP1002 Nanoscale insights into Ion Beam Cancer Therapy (Nano-IBCT).

ЗБОРНИЦИ СКУПОВА НАЦИОНАЛНОГ ЗНАЧАЈА

M 61

1. J. B. Maljković, A. R. Milosavljević, D. Šević and B. P. Marinković,

“Merenje apsolutnih diferencijalnih preseka za elastično rasejanje elektrona na malim biomolekulima”,

Zbornik radova “Fizika 2010 BL”, Banja Luka, Republika Srpska, BiH, 22-24 septembar 2010.

Urednik: B. Predojević, (PMF, Studijki program fizika, Banja Luka, 2011), Sekcijsko predavanje *Sudari elektrona sa atomima i molekulima*, str. 201 – 210.

“Measurements of differential cross sections for elastic electron scattering by small biomolecules”, (in Serbian)

Proceedings “Physics 2010 BL”, Banja Luka, Republic of Srpska, BiH, 22-24 September 2010.

Ed. B. Predojević, Oral presentation within the section *Electron Scattering by Atoms and Molecules*, pp.201 – 210.

Acknowledgements: grant 141011 as well as EU/ESF COST CM0601 “Electron Controlled Chemical Lithography” (ECCL) and MP1002 “Nano-scale Insights in Ion Beam Cancer Therapy (Nano-IBCT). Personal acknowledgements to F. Blanco and G. García.

ISBN: 978-99955-21-21-9

<http://www.fizika.rs.ba/Physics2010BL/sr/index.html>

M63

1. A. R. Milosavljević, J B Maljković, D Šević, I Čadež, and B P Marinković,
“Kinetic energy distribution of positive ions from electron induced dissociative ionization of pyrimidine molecule”

Proc. The First Physics Congress of Bosnia and Herzegovina, 20 – 22. Dec. 2008, Teslić, Republic of Srpska, B&H, Book of Abstracts, Eds. D. Mirjanić, D. Milosević, and B. Predojević, Contributed Papers, Section 2 – Atomic, Molecular and Optical Physics, p.32.

2. J. B. Maljković, A. R. Milosavljević, F. Blanco, D. Šević, G. García and B. P. Marinković,
“Relative Angle-Differential Cross Sections for Elastic Scattering of Electrons from 3-hydroxy-tetrahydrofuran Molecule”,

Proc. 1st National Conference on Electronic, Atomic, Molecular and Photonic Physics, 15-18 May 2008, Zaječar, Serbia, Book of Contributed Papers and Abstracts of Invited Lectures and Progress Reports, Eds. A. R. Milosavljević, D. Šević and B. P. Marinković, (Institute of Physics, Belgrade 2008) ISBN: 978-86-82441-22-9, Contributed Paper, pp.37-41.

<http://uranus.phy.bg.ac.rs/~ceampp/>

ДОКТОРСКА ТЕЗА

M 71

Apsolutni preseki za rasejanje elektrona na organskim molekulima relevantnim za građu bioloških makromolekula

Физички факултет, Универзитет у Београду, 2013

Диференцијални услов- Од првог избора у претходно звање до избора у звање.....	потребно је да кандидат има најмање XX поена, који треба да припадају следећим категоријама:		
		Неопходно XX=	Остварено
Научни сарадник	Укупно	16	100.5
	M10+M20+M31+M32+M33 M41+M42 ≥	10	52.5
	M11+M12+M21+M22 M23+M24 ≥	5	48
Виши научни сарадник	Укупно	48	
	M10+M20+M31+M32+M33 M41+M42+M51 ≥	40	
	M11+M12+M21+M22 M23+M24+M31+M32+M41+M42 ≥	28	
Научни саветник	Укупно	65	
	M10+M20+M31+M32+M33 M41+M42+M51 ≥	50	
	M11+M12+M21+M22 M23+M24+M31+M32 ≥	35	

Search > Author Profile

< Back Remove publications

Maljkovic, Jelena B. *This is an algorithmically generated author record*

University of Belgrade
Inst Phys Belgrade
BELGRADE, SERBIA

Published names Maljkovic, J. B. Maljkovic, Jelena B. Maljkovic, Jelena

Organization 2007-2022 University of Belgrade

PUBLICATIONS AUTHOR IMPACT BEAMPLOT

19 Publications from the Web of Science Core Collection

View as set of results

Date: Newest first All Publications 1 of 1

Absolute Differential Cross-Sections for Elastic Electron Scattering from Sevoflurane Molecule in the Energy Range from 50-300 eV
Vukalovic, Jelena; Maljkovic, Jelena B.; (...); Marinkovic, Bratislav P.
Published 2022 | INTERNATIONAL JOURNAL OF MOLECULAR SCIENCES 0 Times Cited

Elastic Electron Scattering from Methane Molecule in the Energy Range from 50-300 eV
Vukalovic, Jelena; Maljkovic, Jelena B.; (...); Marinkovic, Bratislav P.
Published 2021 | INTERNATIONAL JOURNAL OF MOLECULAR SCIENCES 1 Times Cited

Integral cross sections for elastic electron scattering by methane molecule
Maljkovic, J. B.; Vukovic, J.; (...); Marinkovic, B. P.
Published 2020 | 31ST INTERNATIONAL CONFERENCE ON PHOTONIC, ELECTRONIC AND ATOMIC COLLISIONS (ICPEAC XXXI) 0 Times Cited

Elastic electron scattering cross sections for triethyl phosphate molecule at intermediate electron energies from 50 eV to 250 eV
Maljkovic, Jelena B.; Vukovic, Jelena; (...); Marinkovic, Bratislav P.
Published 2019 | EUROPEAN PHYSICAL JOURNAL D 5 Times Cited

Electron transmission through a steel capillary
Maljkovic, J. B.; Borica, B.; (...); Tokesi, K.
Published 2018 | NUCLEAR INSTRUMENTS & METHODS IN PHYSICS RESEARCH SECTION B-BEAM INTERACTIONS WITH MATERIALS AND ATOMS 1 Times Cited

Elastic electron differential cross sections for argon atom in the intermediate energy range from 40 eV to 300 eV
Rankovic, Milos Lj.; Maljkovic, Jelena B.; (...); Marinkovic, Bratislav P.
Published 2018 | EUROPEAN PHYSICAL JOURNAL D 6 Times Cited

Dissociative electron attachment to coordination complexes of chromium: chromium(0) hexacarbonyl and benzene-chromium(0) tricarbonyl
Kopyra, Janina; Maciejewska, Paulina; Maljkovic, Jelena
Published 2017 | BEILSTEIN JOURNAL OF NANOTECHNOLOGY 5 Times Cited

Are you this Author?

Verify your work, and control how your name, title, institution, and profile image appears in your Web of Science Author Record.

Claim my record

Metrics

Publication Metrics

7 H-Index 19 Total Publications

154 Sum of Times Cited 132 Citing Articles

View citation report

Author Impact Beamplot Summary

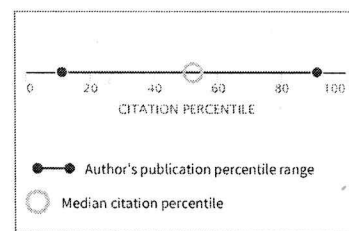

Percentile range displays for authors from 1990 to 2020. View all publications in full beamplot.

View full beamplot

Author Position

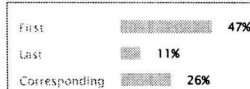

<p>Study of electron transmission through a platinum tube Milosavljevic, A. R.; Rankovic, M. Lj.; (...); Tokesi, K. Published 2015 NUCLEAR INSTRUMENTS & METHODS IN PHYSICS RESEARCH SECTION B-BEAM INTERACTIONS WITH MATERIALS AND ATOMS</p>	5 Times Cited
<p>Study of electron transmission through a metallic capillary Milosavljevic, A. R.; Rankovic, M. Lj.; (...); Tokesi, K. Published 2015 JOURNAL OF PHYSICS CONFERENCE SERIES</p>	0 Times Cited
<p>Absolute differential cross sections for elastic electron scattering from small biomolecules Maljkovic, Jelena Published 2014 27TH SUMMER SCHOOL AND INTERNATIONAL SYMPOSIUM ON THE PHYSICS OF IONIZED GASES (SPIG 2014)</p>	1 Times Cited
<p>Electron impact excitation of methane: determination of appearance energies for dissociation products Danko, M.; Orszagh, J.; (...); Matejcek, S. Published 2013 JOURNAL OF PHYSICS B-ATOMIC MOLECULAR AND OPTICAL PHYSICS</p>	21 Times Cited
<p>Absolute cross sections for electron scattering from furan Maljkovic, J. B.; Blanco, E.; (...); Milosavljevic, A. R. Published 2012 JOURNAL OF CHEMICAL PHYSICS</p>	10 Times Cited
<p>Elastic electron scattering from formamide molecule Maljkovic, J. B.; Blanco, E.; (...); Milosavljevic, A. R. Published 2012 NUCLEAR INSTRUMENTS & METHODS IN PHYSICS RESEARCH SECTION B-BEAM INTERACTIONS WITH MATERIALS AND ATOMS</p>	9 Times Cited
<p>Absolute cross sections for elastic electron scattering from methylformamide Maljkovic, J. B.; Blanco, E.; (...); Milosavljevic, A. R. Published 2012 PHYSICAL REVIEW A</p>	11 Times Cited
<p>Absolute differential cross sections for elastic scattering of electrons from pyrimidine Maljkovic, J. B.; Milosavljevic, A. R.; (...); Marinkovic, B. P. Published 2009 PHYSICAL REVIEW A</p>	53 Times Cited
<p>Absolute cross sections for elastic electron scattering from 3-hydroxytetrahydrofuran Milosavljevic, A. R.; Blanco, E.; (...); Marinkovic, B. P. Published 2008 NEW JOURNAL OF PHYSICS</p>	16 Times Cited
<p>RELATIVE ANGLE-DIFFERENTIAL CROSS SECTIONS FOR ELASTIC ELECTRON SCATTERING FROM PYRIMIDINE Maljkovic, J. B.; Milosavljevic, A. R.; (...); Marinkovic, B. P. Published 2008 24TH SUMMER SCHOOL AND INTERNATIONAL SYMPOSIUM ON THE PHYSICS OF IONIZED GASES, CONTRIBUTED PAPERS</p>	1 Times Cited
<p>Optical and electron spectrometry of molecules of biological interest Marinkovic, B. P.; Milosavljevic, A. R.; (...); Pejcev, V. Published 2007 ACTA PHYSICA POLONICA A</p>	1 Times Cited
<p>Cross section data for electron collisions in plasma physics Marinkovic, B. P.; Pejcev, V.; (...); Maljkovic, J. B. Published 2007 JOURNAL OF PHYSICS CONFERENCE SERIES</p>	8 Times Cited