

Uticaj rasejanja na LO fononima i površinskim neravninama na rad kvantno kaskadnog lasera u jakom magnetnom polju

Milan Žeželj

Laboratorija za primenu računara u nauci

Institut za fiziku Beograd

e-mail: milan.zezelj@scl.rs

Prof. dr Vitomir Milanović

Prof. dr Jelena Radovanović

Katedra za mikроеlektroniku i tehničku fiziku

Elektrotehnički fakultet Univerziteta u Beogradu



Ilustracija međuzonskog i unutarzonskog optičkog prelaza (1)

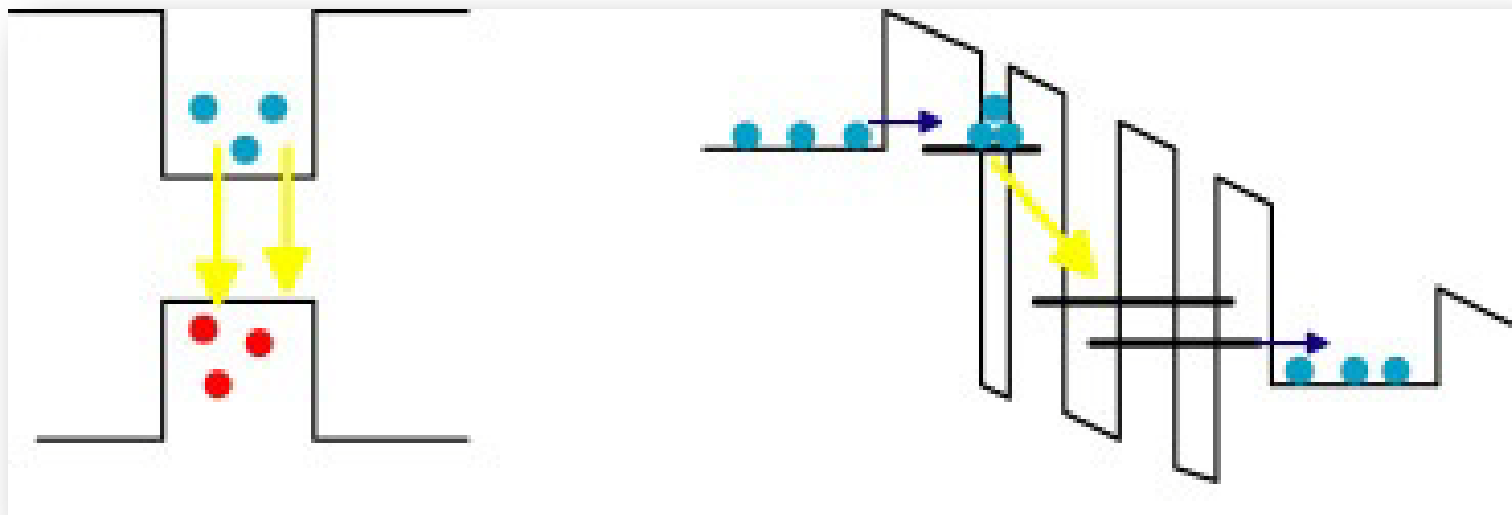

<http://www.qoe.ethz.ch/research/topics/t-qcl>

Ilustracija međuzonskog i unutarzonskog optičkog prelaza (2)

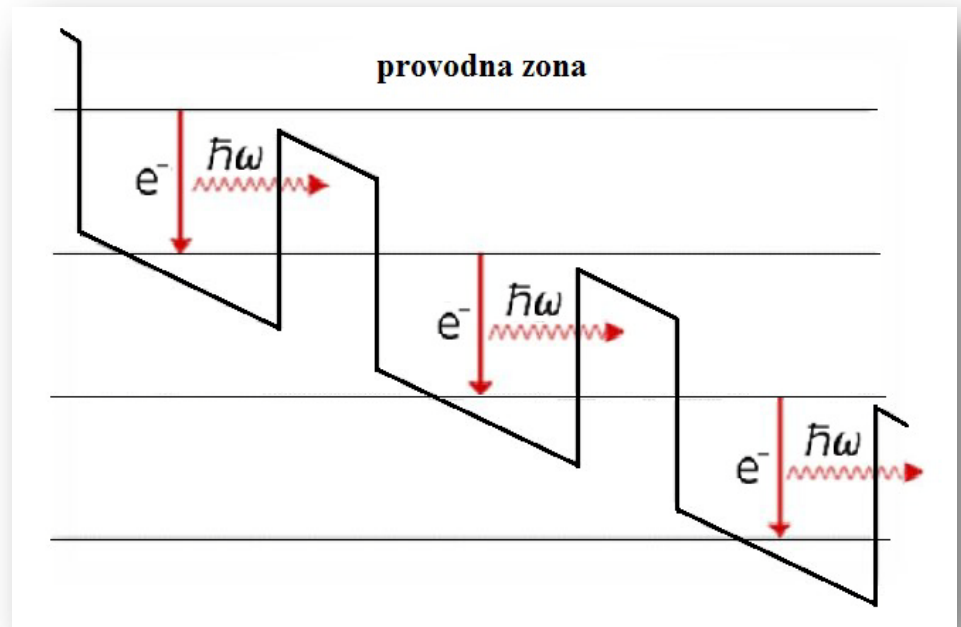
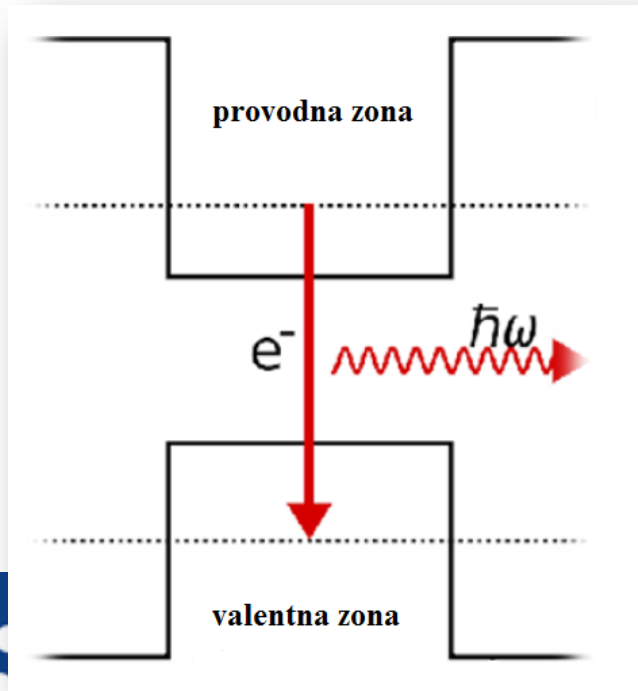

http://en.wikipedia.org/wiki/Quantum_cascade_laser

Kvantno kaskadni laser (1)

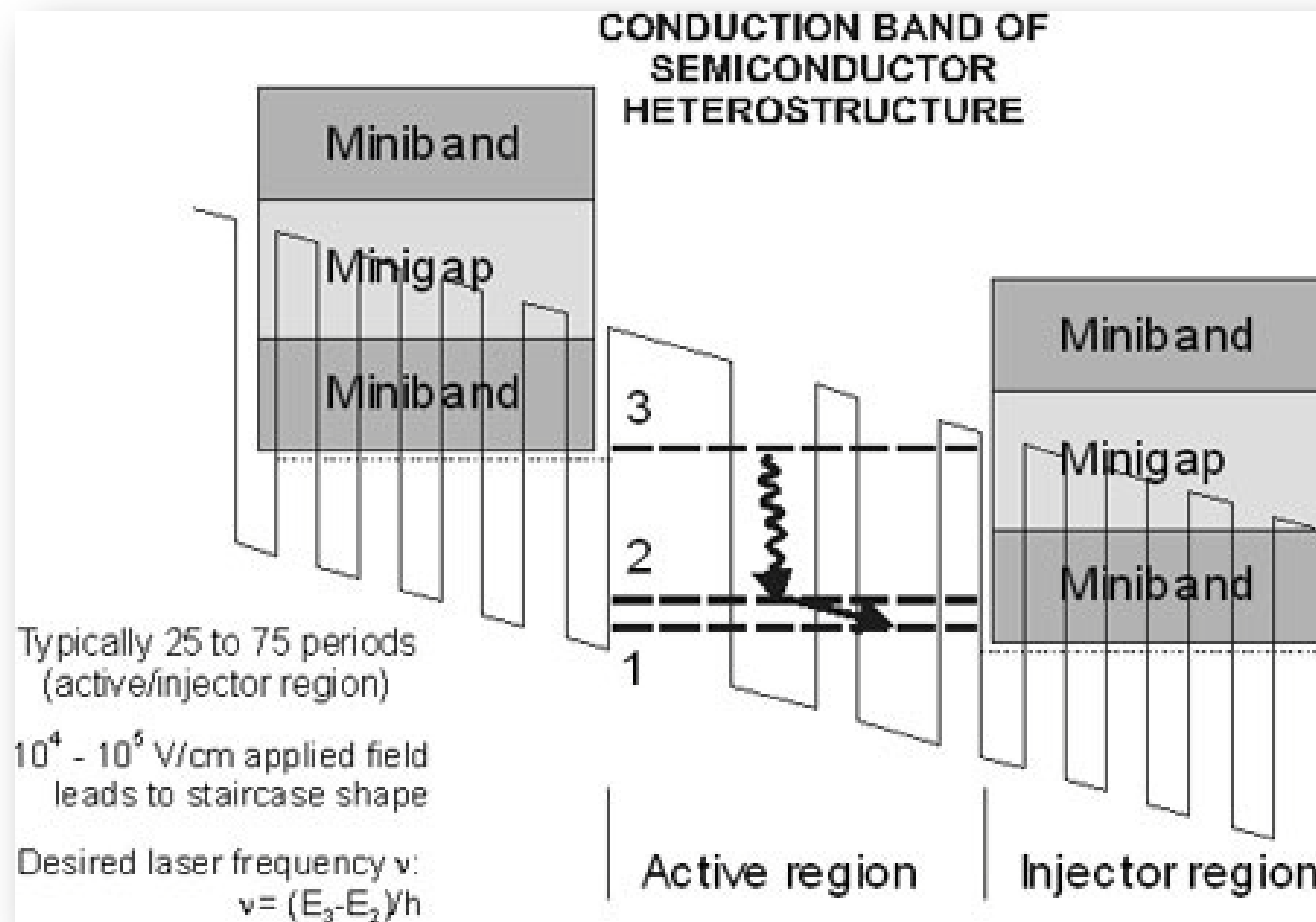

Kvantno kaskadni laser (2)

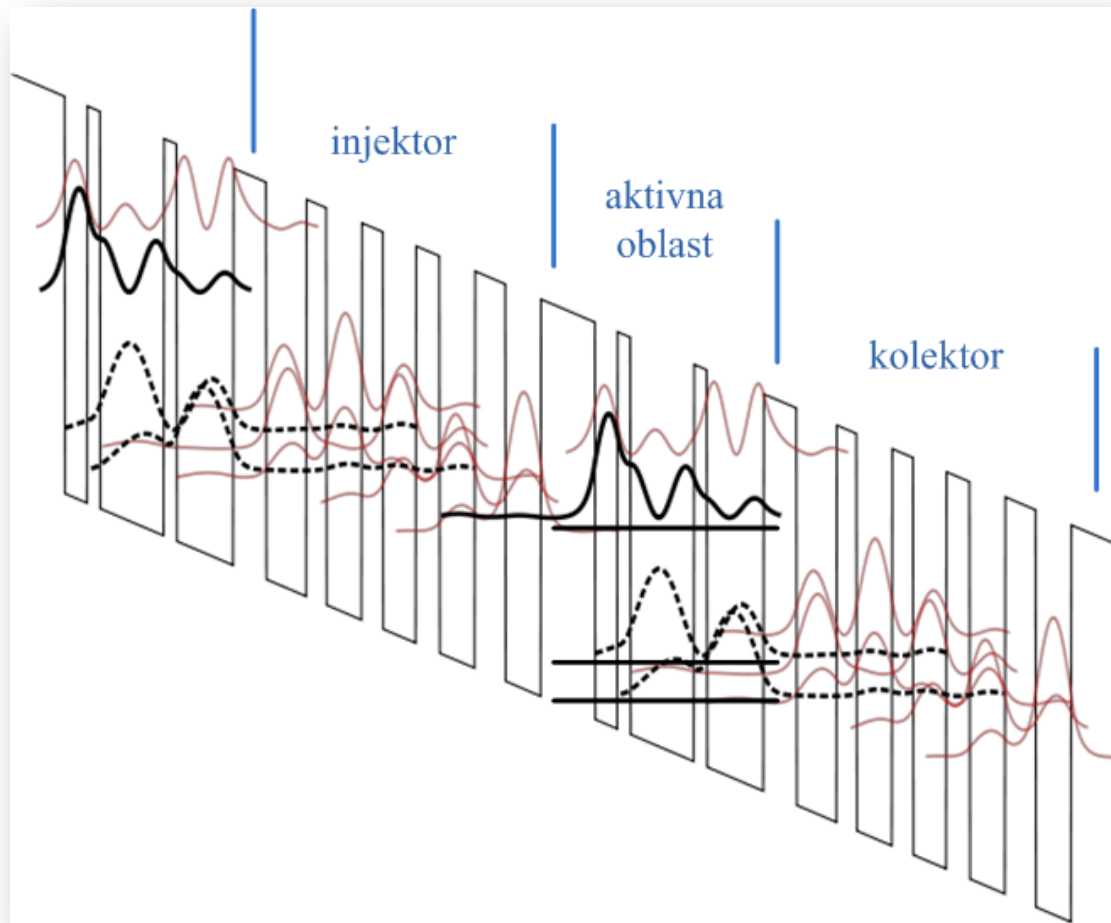

S. Ramović, Master rad

Prikaz periodične strukture kvantno kaskadnog

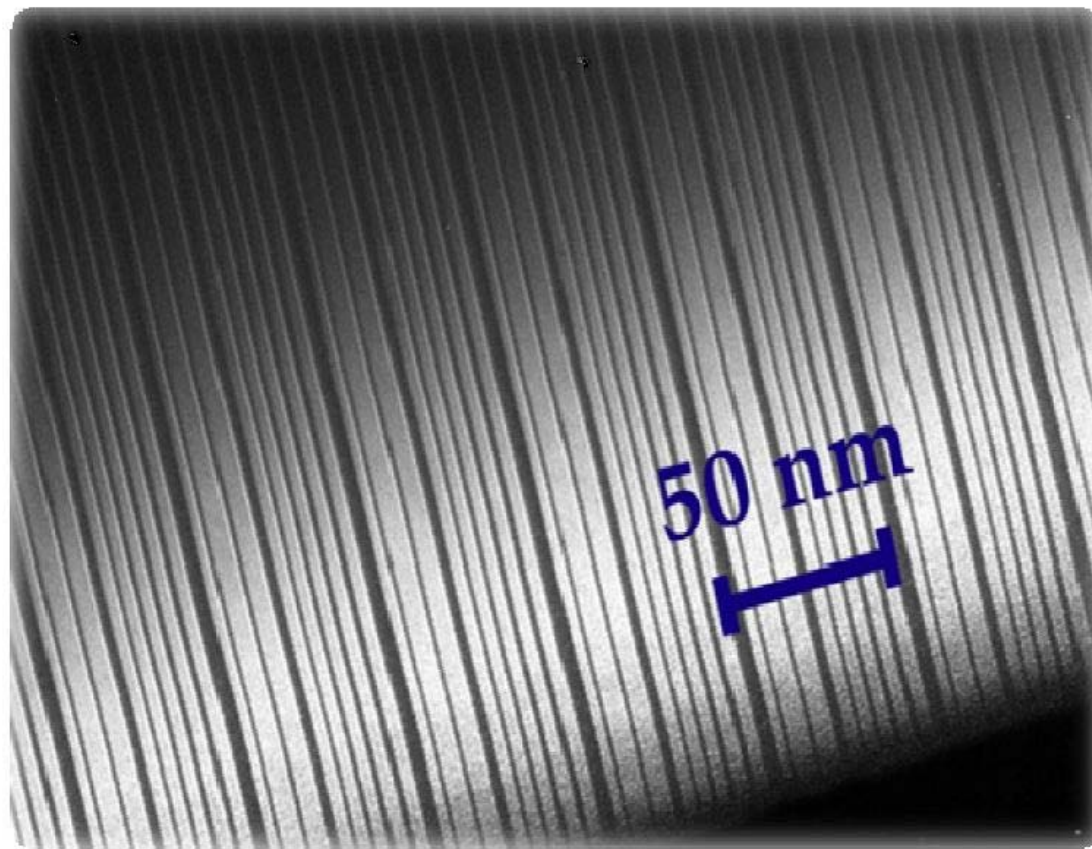

Potencijal dna provodne zone bez prisustva spoljašnjeg polja - aktivna oblast

(D. Smirnov *et al.*, PRB 66, 125317 (2002) → dimenzije strukture)

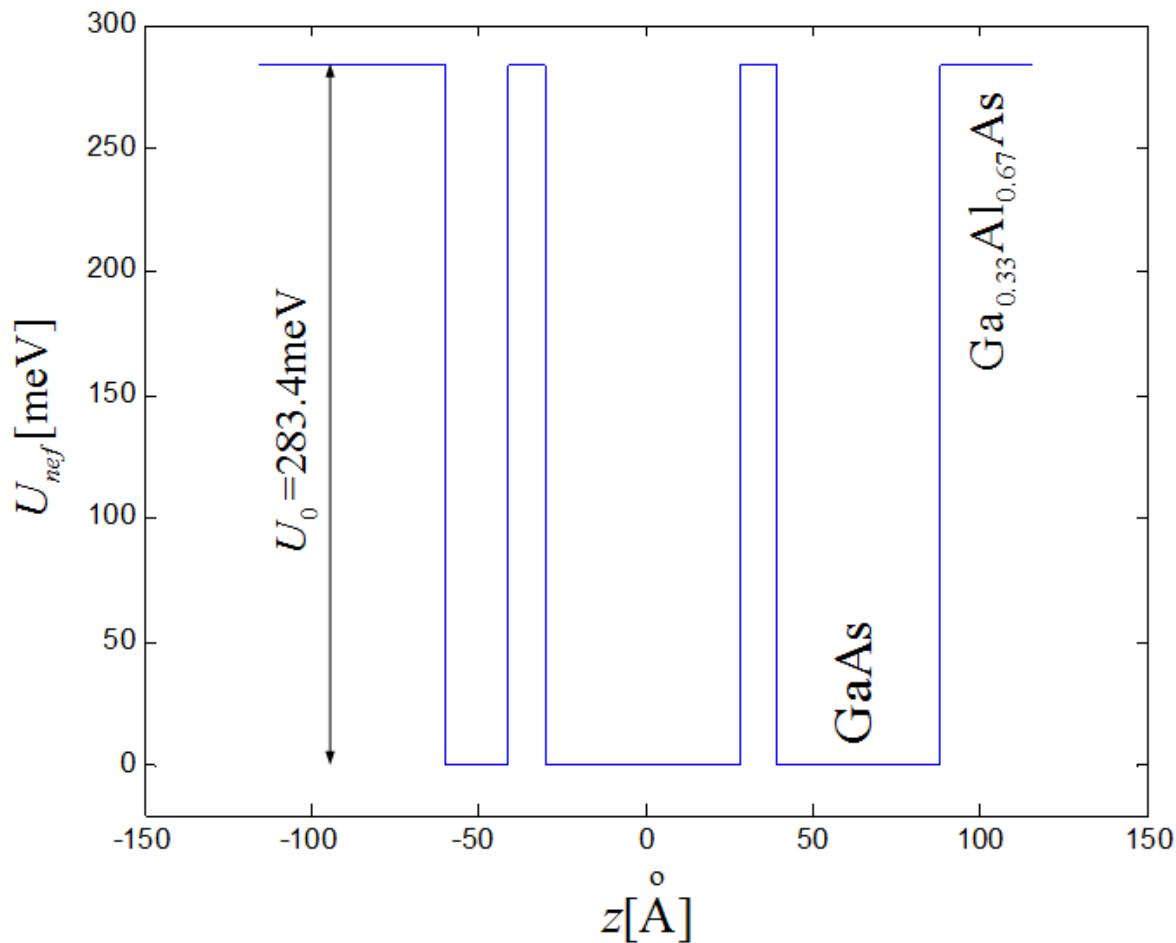

Električno polje u smeru z - ose

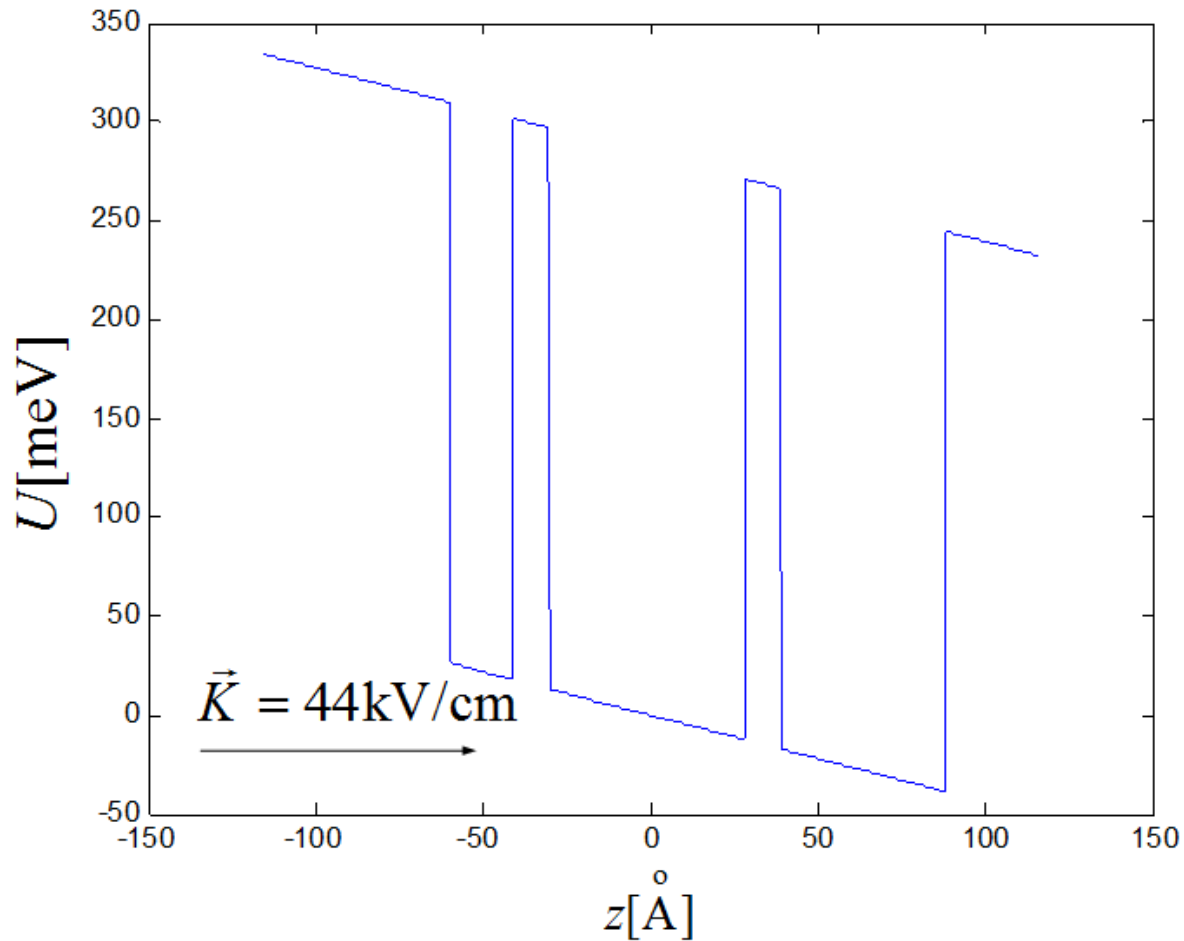

Šredingerova jednačina

$$-\frac{\hbar^2}{2} \frac{d}{dz} \left\{ \frac{1}{m_{\perp}(z, E_n)} \left[\frac{d\eta(z)}{dz} \right] \right\} + U(z)\eta(z) = E_n\eta(z)$$

Efekat neparaboličnosti - longitudinalna masa

U.Ekenberg, PRB 40,
7714 (1989)

$$m_{\perp}(z, E_n) = \begin{cases} (m_{AlAs} X + m_{GaAs} (1-X)) \left(1 + \frac{E_n - U_0}{E_{gb}} \right) \\ m_{GaAs} \left(1 + \frac{E_n}{E_{gw}} \right) \end{cases}$$

$$m_{GaAs} = 0.067m_0$$

$$E_{gw} = 1.5041\text{eV}$$

$$X = 0.33$$

$$m_{AlAs} = 0.15m_0$$

$$E_{gb} = 1.9624\text{eV}$$



Struktura provodne i valentne zone

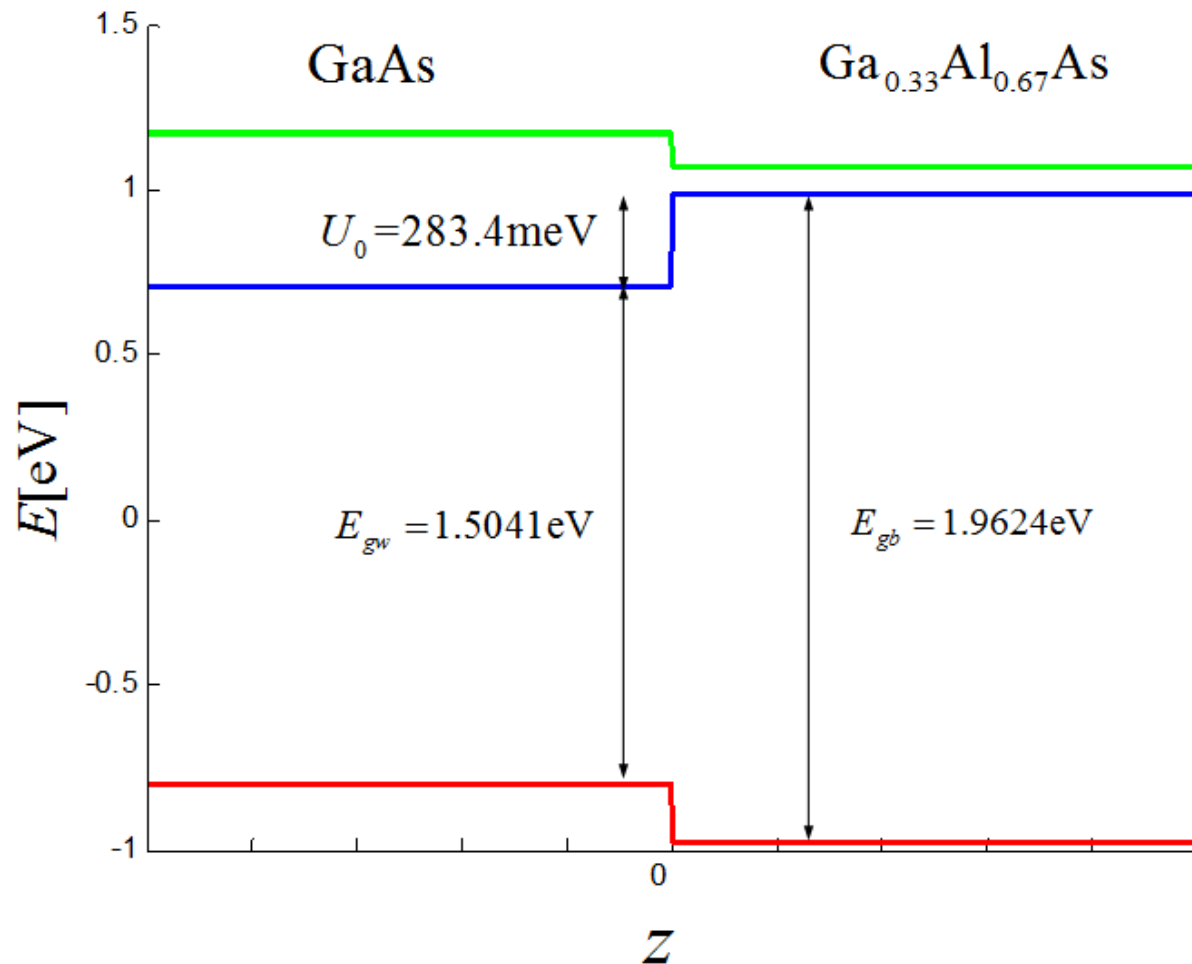

Sopstvene funkcije i energije dobijene *shooting* metodom

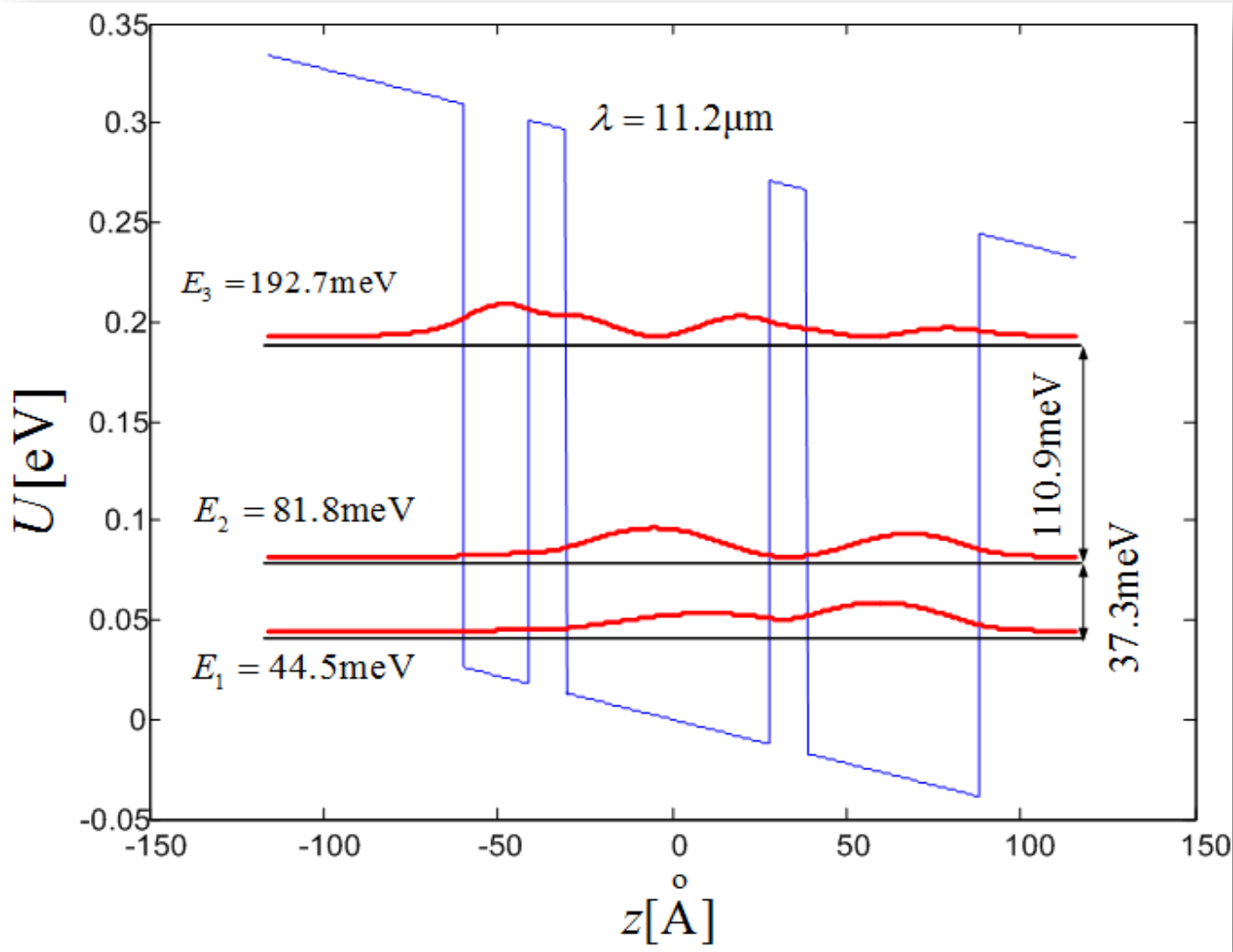

Efekat neparaboličnosti - longitudinalna masa

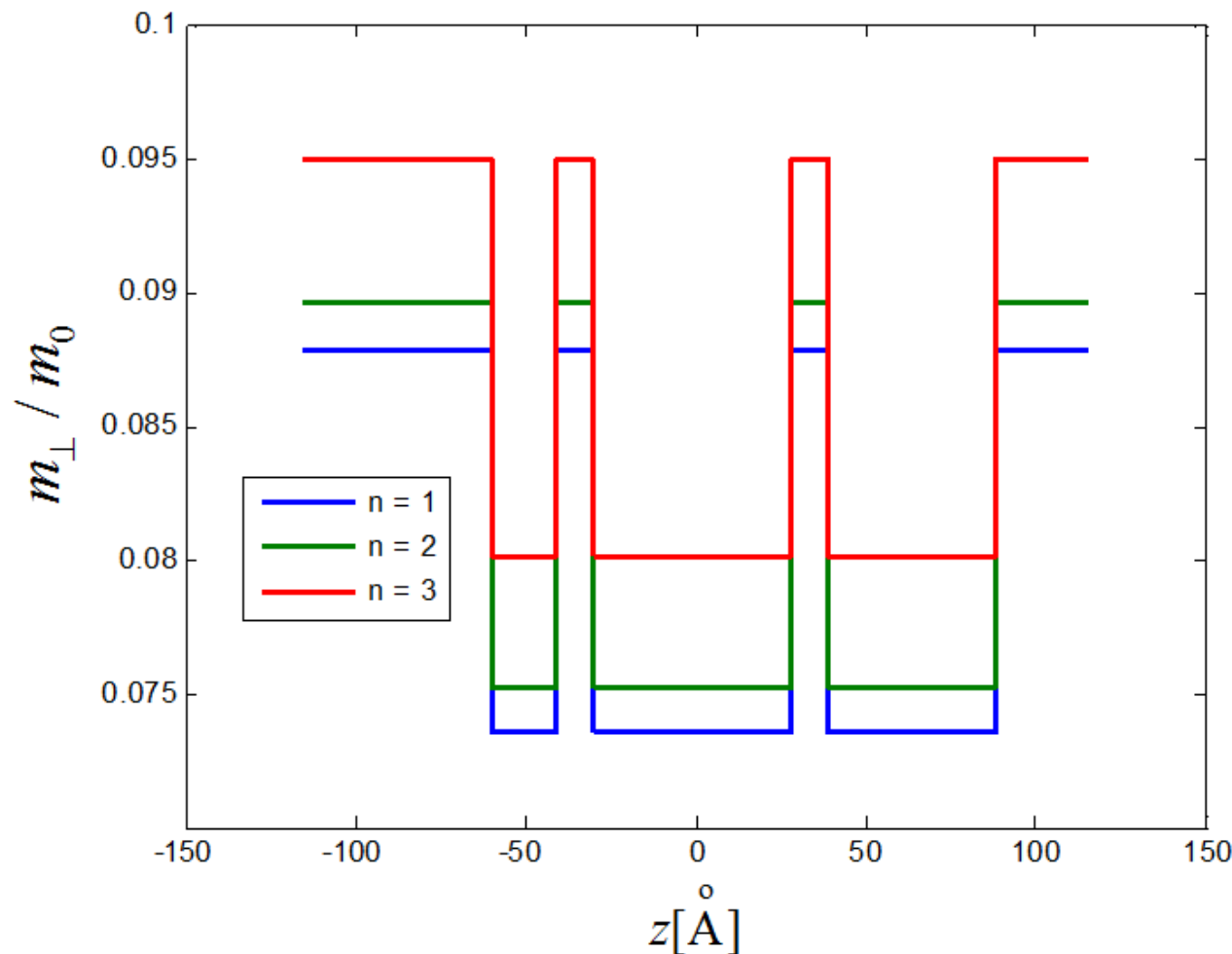

Magnetsko polje

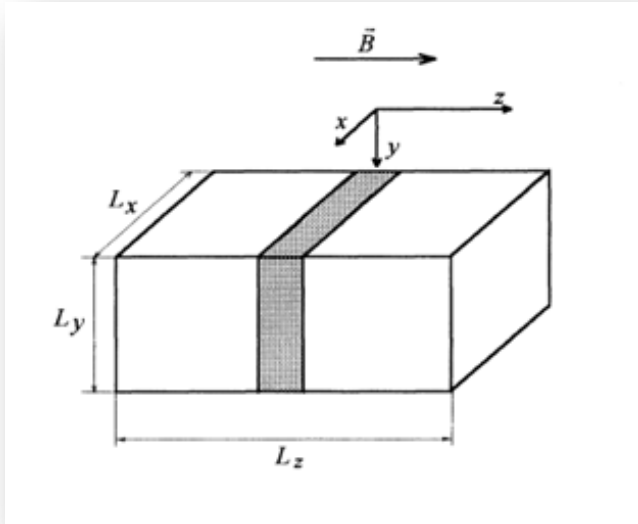

$$\vec{B} = B\vec{e}_z$$

$$\vec{A}_M = -By\vec{e}_x$$

$$\psi(x, y, z) = \frac{e^{ik_x x}}{\sqrt{L_x}} \Phi_j(y - y_0) \eta(z)$$

$$y_0 = \hbar k_x / eB$$

$$-\frac{\hbar^2}{2} \frac{d}{dz} \left(\frac{1}{m_{\perp}(z, E)} \frac{d\eta(z)}{dz} \right) + \left(U(z) + \frac{eB\hbar}{m_{\parallel}(z, E)} \left(l + \frac{1}{2} \right) \right) \eta(z) = E\eta(z)$$

S. Živanović *et al.*, PRB 52, 8305 (1995)

Energije nakon primene magnetskog polja

$$E_{n,l}(B) = E_n + (l+1/2) \frac{\hbar e B}{m_{\parallel}(E_n)} - \frac{1}{8} \left[(8l^2 + 8l + 5) \alpha_1' + (l^2 + l + 1) \beta_1' \right] \left(\frac{\hbar e B}{m_w} \right)^2$$

Efekat neparaboličnosti - transverzalna masa

U.Ekenberg, PRB 40,
7714 (1989)

$$\overline{m_{\parallel}^{-1}}(E_n) = \int \eta_n^2(z) m_{\parallel}^{-1}(z, E_n) dz$$

$$m_{\parallel}(z, E_n) = m_w \left\{ 1 + (2\alpha_1' + \beta_1') [E_n - U_{nef}(z)] \right\}$$

$$\alpha_1' = 0.642 \text{eV}^{-1} \quad \beta_1' = 0.697 \text{eV}^{-1}$$



Energije za 10T

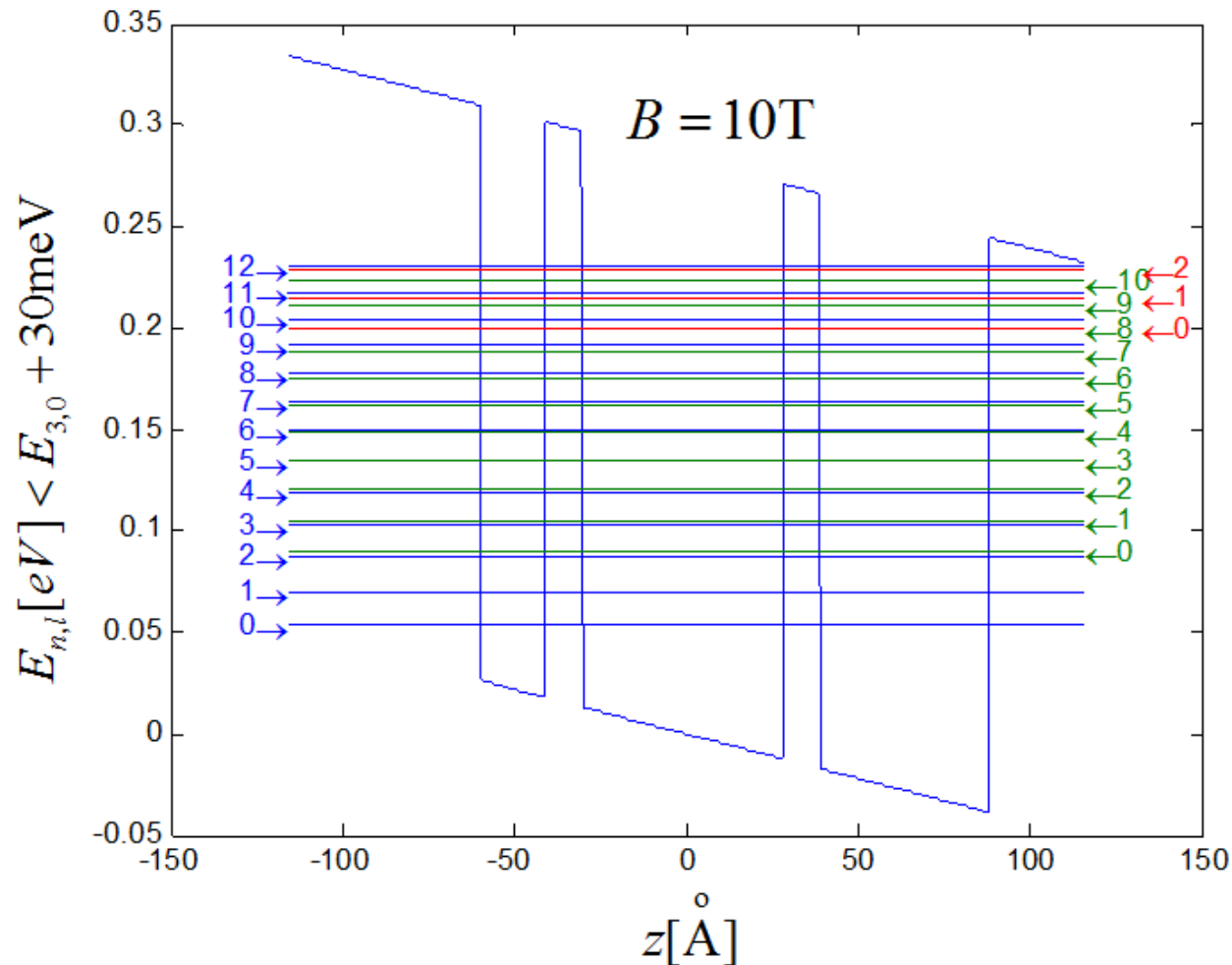

Energije za 60T

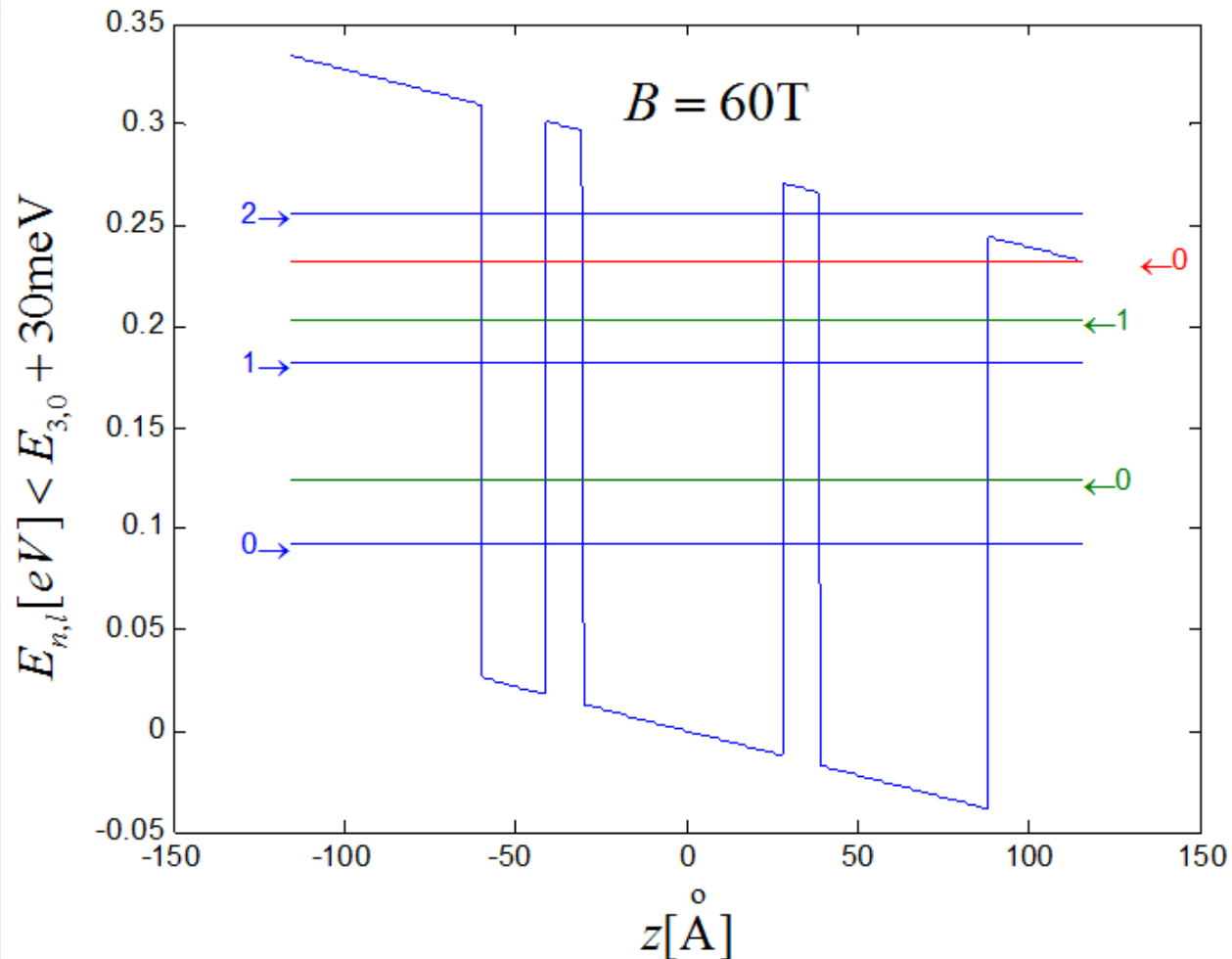

Širine jama imaju Gauss-ovu raspodelu

C. Weisbuch et al, SSC 38, 709 (1981)

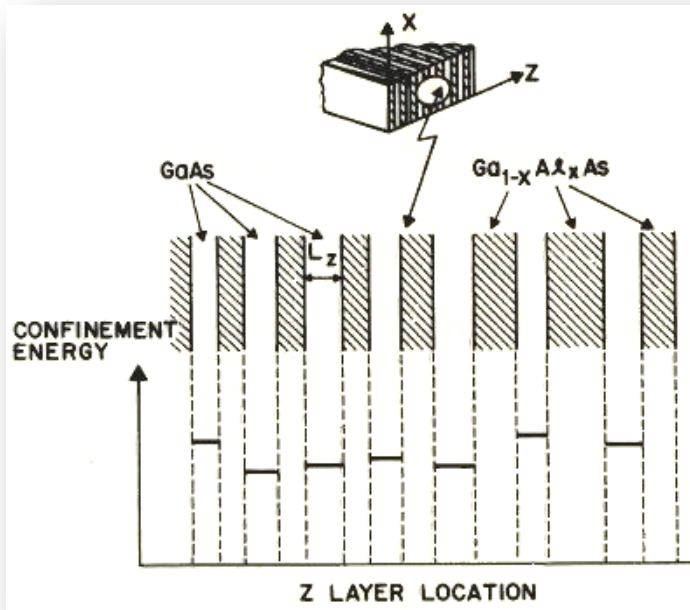

$$\Pi(L_i) = \frac{1}{\sigma\sqrt{2\pi}} e^{-\frac{(L-L_{i0})^2}{2\sigma^2}}$$

$$J = \int_{-\infty}^{+\infty} \Pi(L_i) \delta(E_{n_i, l_i} - E_{n_f, l_f} - \Delta E) dL_i$$

$$E_{n_i, l_i}(L_i) - E_{n_f, l_f}(L_i) \approx E_{n_i, l_i}(L_{i0}) - E_{n_f, l_f}(L_{i0}) - \gamma(L_i - L_{i0})$$

$$J = \frac{1}{\delta\sqrt{2\pi}} e^{-\frac{(E_{n_i, l_i} - E_{n_f, l_f} - \Delta E)^2}{2\delta^2}}$$

$$\delta = \sigma\gamma = 6\text{meV}$$

C.Becker et al., PRB 69, 115328 (2004)

Elektrona - LO fonon interakcija

$$\hat{H}_{e-ph} = \sum_{\vec{q}} \hat{H}_{e-ph}(\vec{q}),$$

$$\hat{H}_{e-ph}(\vec{q}) = i \frac{g}{q} (e^{-i\vec{q} \cdot \vec{r}} a_{\vec{q}}^{\dagger} - e^{i\vec{q} \cdot \vec{r}} a_{\vec{q}}),$$

g je Frölich faktor:

$$g^2 = 2 \pi \hbar \omega_{LO} \frac{e^2}{\epsilon_p V},$$

$$\epsilon_p = \frac{4 \pi \epsilon_0}{\epsilon_{\infty}^{-1} - \epsilon_s^{-1}},$$

$$\hbar \omega_{LO} = 37.25 \text{ meV}$$

$$\epsilon_{\infty} = 10.67$$

$$\epsilon_s = 12.51$$

C.Becker *et al.*, PRB 69, 115328 (2004)



Brzina rasejanja elektron – LO fonon

(J. Radovanović et al., JAP 97, 103109 (2005) → zanemariti AC)

$$\frac{1}{\tau_{(n_i, l_i) \rightarrow (n_f, l_f)}^{LO}} = \frac{2\pi}{\hbar} \sum_{\vec{q}} \left| \left\langle n_f, l_f, k_{x_f}, n_q \pm 1 \left| \hat{H}_{e-ph}(\vec{q}) \right| n_i, l_i, k_{x_i}, n_q \right\rangle \right|^2 J^{LO}$$

Emisija fonona:

$$\frac{1}{\tau_{(n_i, l_i) \rightarrow (n_f, l_f)}^{LO, \{e\}}} = \frac{e^2 \omega_{LO}}{4\epsilon_0} \left(\frac{1}{\epsilon_\infty} - \frac{1}{\epsilon_s} \right) \frac{1}{\delta \sqrt{2\pi}} e^{-\frac{(E_{n_i, l_i} - E_{n_f, l_f} - \hbar \omega_{LO})^2}{2\delta^2}} (n_q + 1) \int_0^\infty |F(q_{\parallel})|^2 G(q_{\parallel}) dq_{\parallel}$$

$$n_q = \frac{1}{e^{\frac{\hbar \omega_{LO}}{k_B T}} - 1} \quad |F(q_{\parallel}, l_i, l_f)|^2 = e^{-\frac{q_{\parallel}^2}{2\beta^2}} \frac{l_i!}{l_f!} \left(\frac{q_{\parallel}^2}{2\beta} \right)^{l_f - l_i} \left[L_{l_i}^{l_f - l_i} \left(\frac{q_{\parallel}^2}{2\beta} \right) \right]^2, \quad \beta = \sqrt{\frac{eB}{\hbar}}$$

$$G(q_{\parallel}) = \iint \eta_i^*(z) \eta_f(z) \eta_i(z') \eta_f^*(z') e^{-q_{\parallel} |z - z'|} dz dz'$$

C.Becker *et al.*, PRB 69, 115328 (2004) i V. Milanović, izvođenje



Apsorpcija fonona

$$\frac{1}{\tau_{(n_f, l_f) \rightarrow (n_i, l_i)}^{\text{LO}, \{a\}}} = \frac{1}{\tau_{(n_i, l_i) \rightarrow (n_f, l_f)}^{\text{LO}, \{e\}}} \frac{1}{e^{\frac{\hbar\omega_{LO}}{kT}}}$$

$$e^{\frac{\hbar\omega_{LO}}{kT}} \approx \begin{cases} 200, T = 77\text{K} \\ 4, T = 300\text{K} \end{cases}$$

Zanemariti?

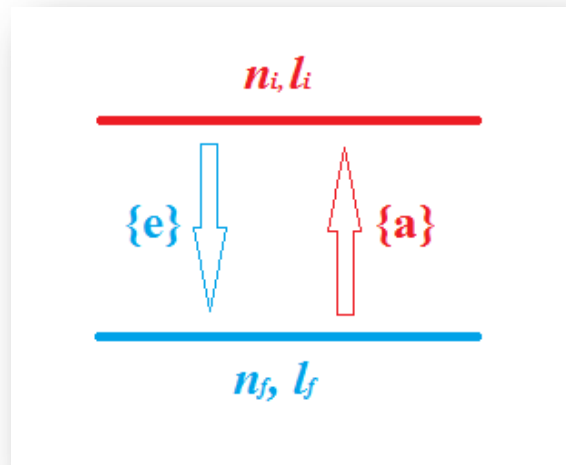

Interface roughness

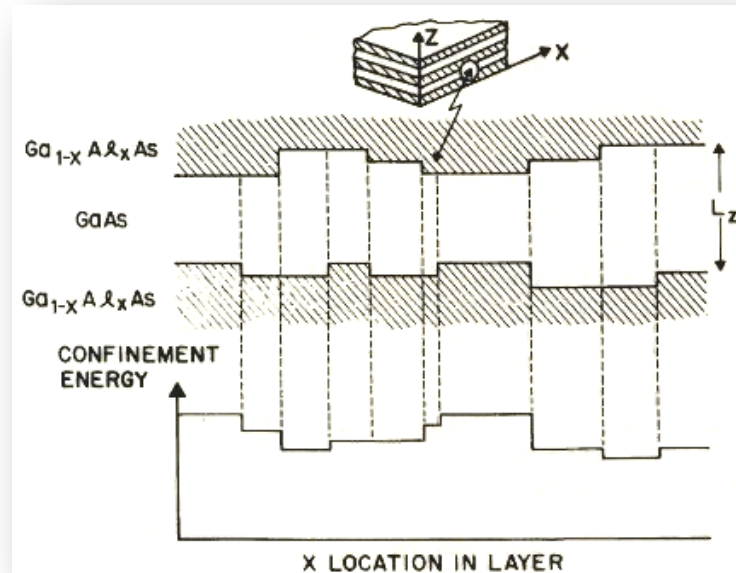

C. Weisbuch *et al*, SSC 38, 709 (1981)

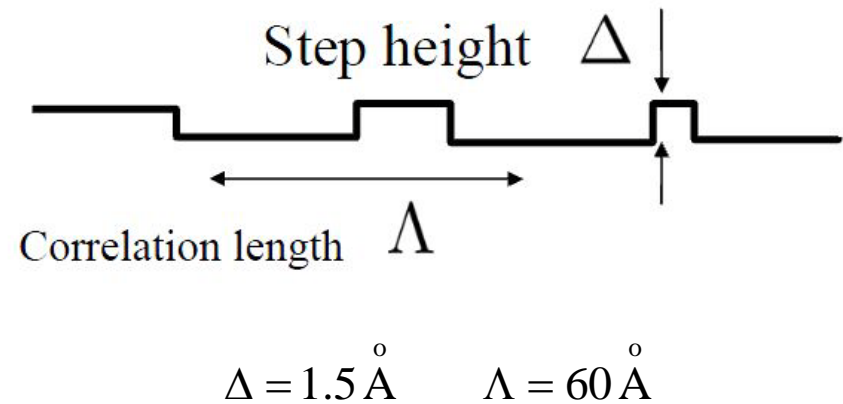

Gauss-ova korelaciona funkcija

T. Unuma *et al.*, JAP, 93, 1586 (2003)

$$\langle \Delta(\vec{r}) \Delta(\vec{r}') \rangle = \Delta^2 e^{-\frac{|\vec{r}-\vec{r}'|}{\Lambda}}$$

Brzina rasejanja na površinskim neravninima

$$\left\langle \frac{1}{\tau_{(n_i, l_i) \rightarrow (n_f, l_f)}^{IR}}(z_i) \right\rangle = \frac{2\pi}{\hbar} \left\langle \sum_{k_{x_i}, k_{x_f}} \left\langle \left| \langle n_f, l_f, k_{x_f} | \hat{H}_{IR} | n_i, l_i, k_{x_i} \rangle \right|^2 \right\rangle \right\rangle J^{IR}$$

$$\hat{H}_{IR} = U_0 \delta(z - z_i) \Delta(x, y) \quad J^{IR} = \frac{1}{\delta \sqrt{2\pi}} e^{-\frac{(E_{n_i, l_i} - E_{n_f, l_f})^2}{2\delta^2}}$$

$$\frac{1}{\tau_{(n_i, l_i) \rightarrow (n_f, l_f)}^{IR}} = \sum_{z_i} \left\langle \frac{1}{\tau_{(n_i, l_i) \rightarrow (n_f, l_f)}^{IR}}(z_i) \right\rangle$$

$$\frac{1}{\tau_{(n_i, l_i) \rightarrow (n_f, l_f)}^{IR}} = \frac{1}{\tau_{(n_f, l_f) \rightarrow (n_i, l_i)}^{IR}}$$

T. Unuma *et al.*, JAP 93, 1586 (2003) i V. Milanović, izvođenje

LO vs. IR

$$J^{LO} = \frac{1}{\delta\sqrt{2\pi}} e^{-\frac{(E_{n_i, l_i} - E_{n_f, l_f} - \hbar\omega_{LO})^2}{2\delta^2}}$$

$$J^{IR} = \frac{1}{\delta\sqrt{2\pi}} e^{-\frac{(E_{n_i, l_i} - E_{n_f, l_f})^2}{2\delta^2}}$$

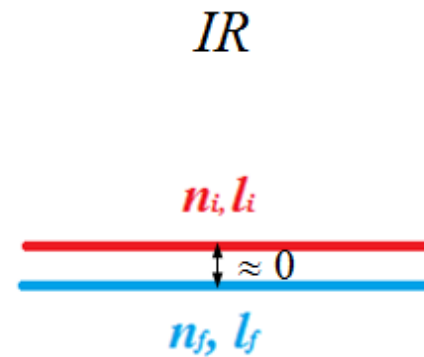
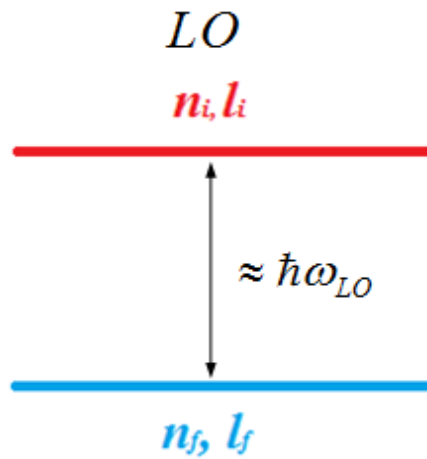

Struje

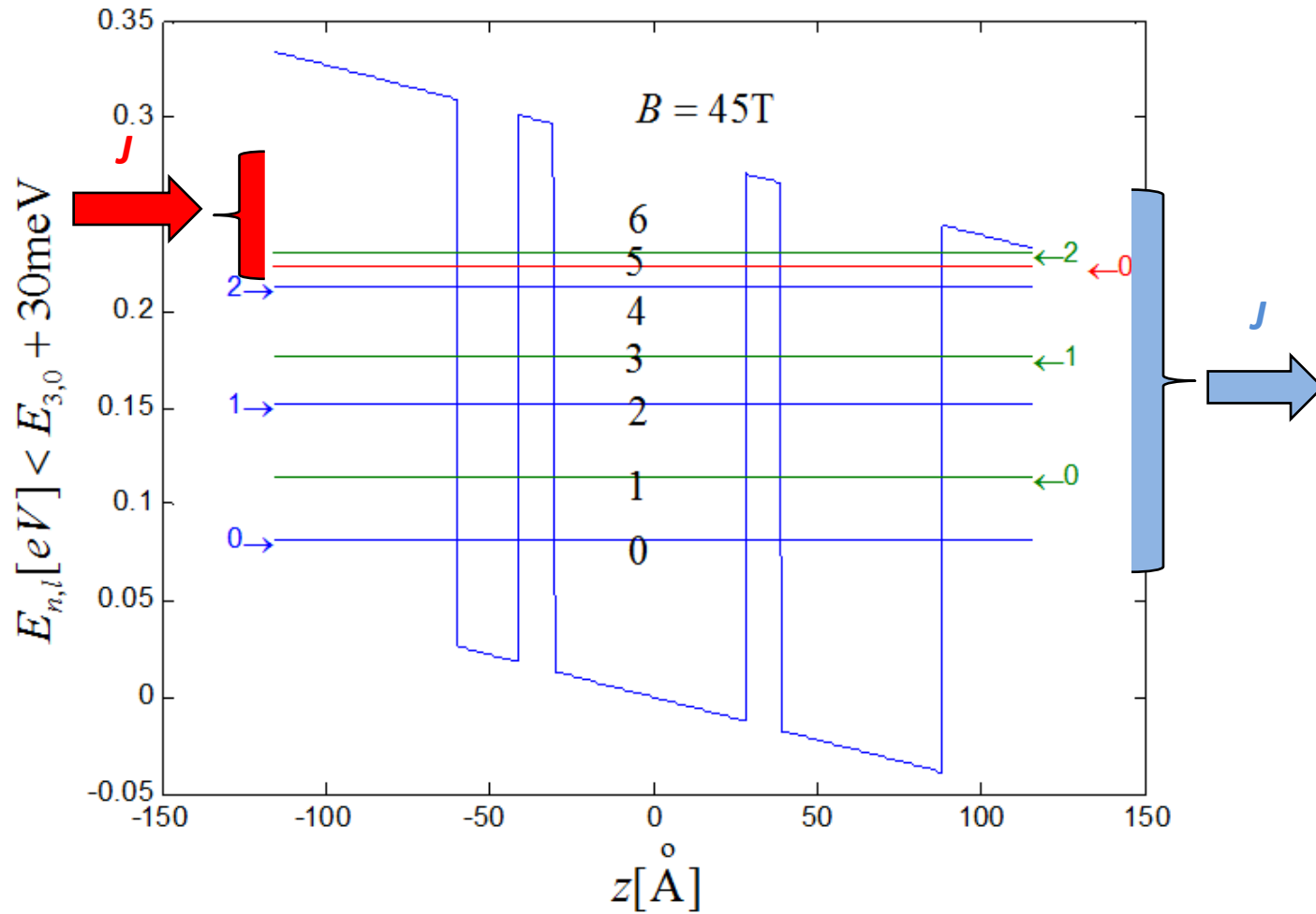

Brzinske jednačine

$$N_i \sum_{j \neq i} \frac{\bar{f}(E_j)}{\tau_{i \rightarrow j}} - \bar{f}(E_i) \sum_{j \neq i} \frac{N_j}{\tau_{j \rightarrow i}} + \frac{J_i}{e} = 0$$

$$\bar{f}(E_k) = 1 - \frac{\pi \hbar}{eB} N_k$$

$$J_i = \begin{cases} -J \frac{e^{-E_{3,i}/k_B T}}{\sum_k e^{-E_{3,k}/k_B T}} \\ J \frac{e^{-E_{1,i}/k_B T}}{\sum_k e^{-E_{1,k}/k_B T}} \end{cases}$$

J. Radovanović et al., JAP
97, 103109 (2005)

Nelinearne, iterativno ...



Optičko pojačanje

$$g_{3 \rightarrow 2} = \frac{2e^2 \pi^2}{\bar{n} \epsilon_0} \frac{d_{3 \rightarrow 2}^2}{\lambda} \sum_i \delta(E_{3,i} - E_{2,i} - \hbar\omega) (N_{3,i} - N_{2,i})$$

$$\bar{n} = 3.3$$

$$d_{3 \rightarrow 2} = \int \eta_3 z \eta_2 dz + \frac{\hbar^2}{2(E_3 - E_2)} \int \eta_3 \frac{d}{dz} \left\{ \left(\frac{1}{m_2} - \frac{1}{m_3} \right) z \frac{d\eta_2}{dz} \right\} dz$$

$$g = \frac{g_{3 \rightarrow 2}}{J}$$

V. Milanović izvođenje



Brzina verovatnoće prelaza sa nivoa (3, 0) na ostale nivoe

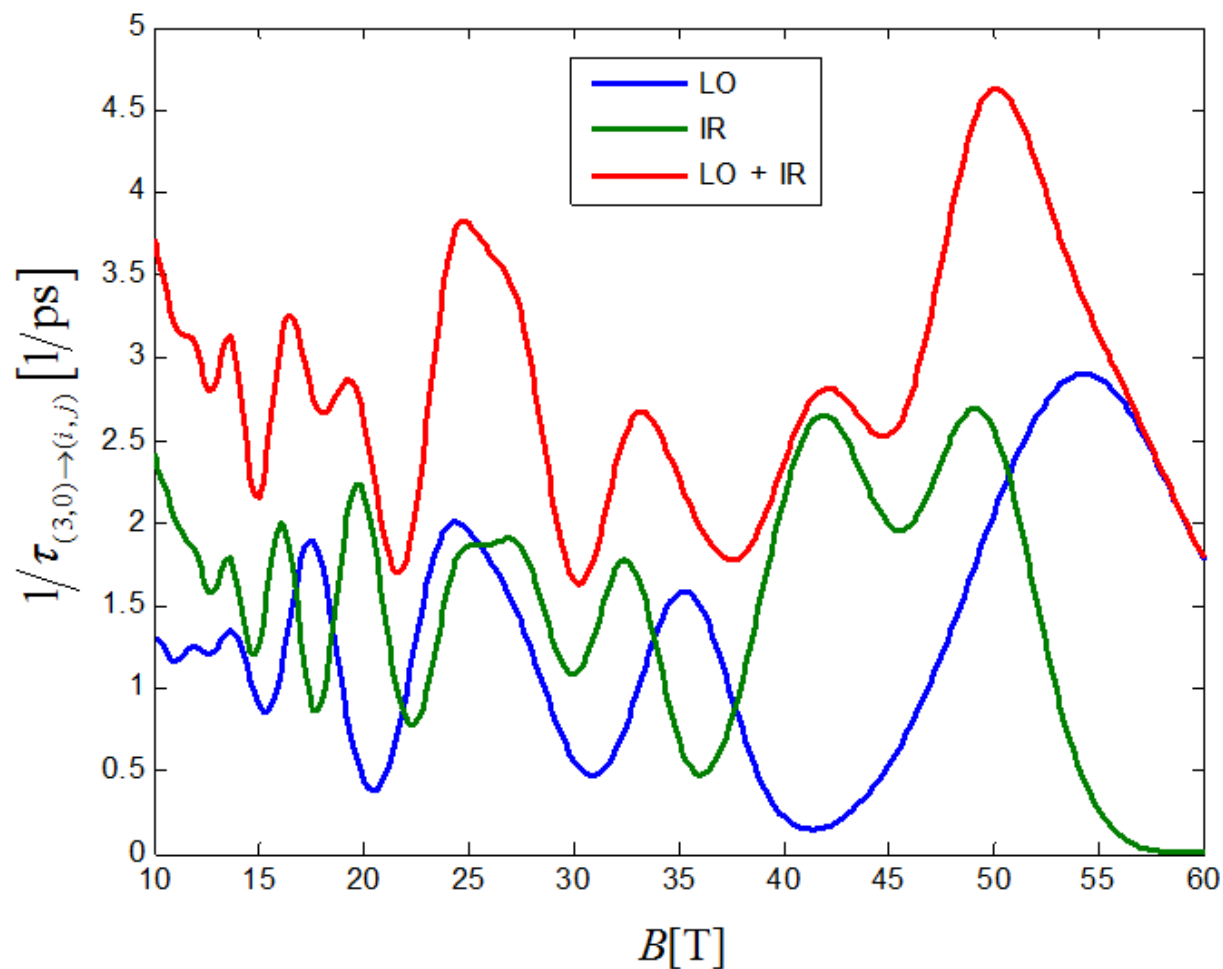

Odnos površinskih koncentracija elektrona na nivoima (3, 0) i (2, 0)

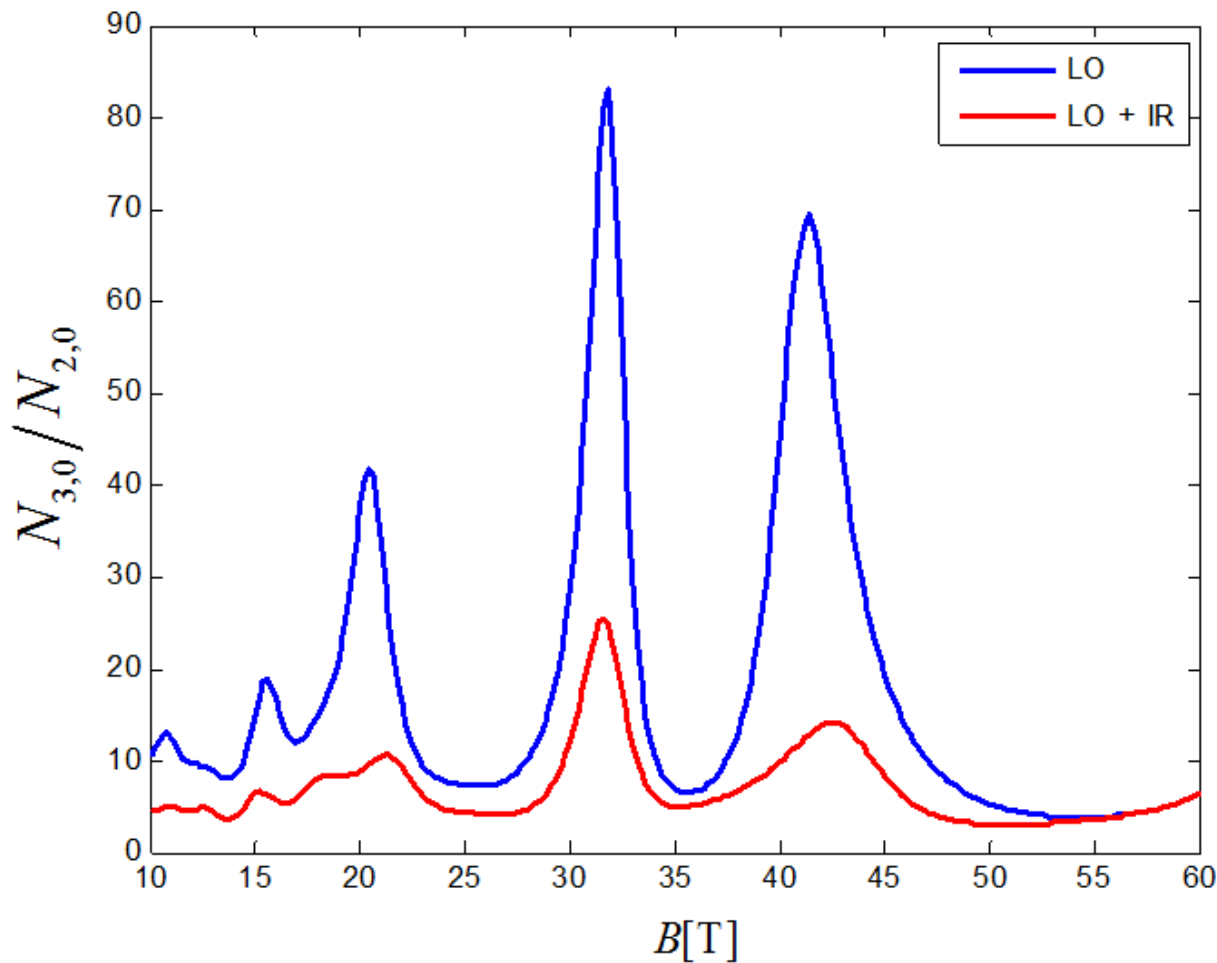

Optičko pojačanje QCL-a

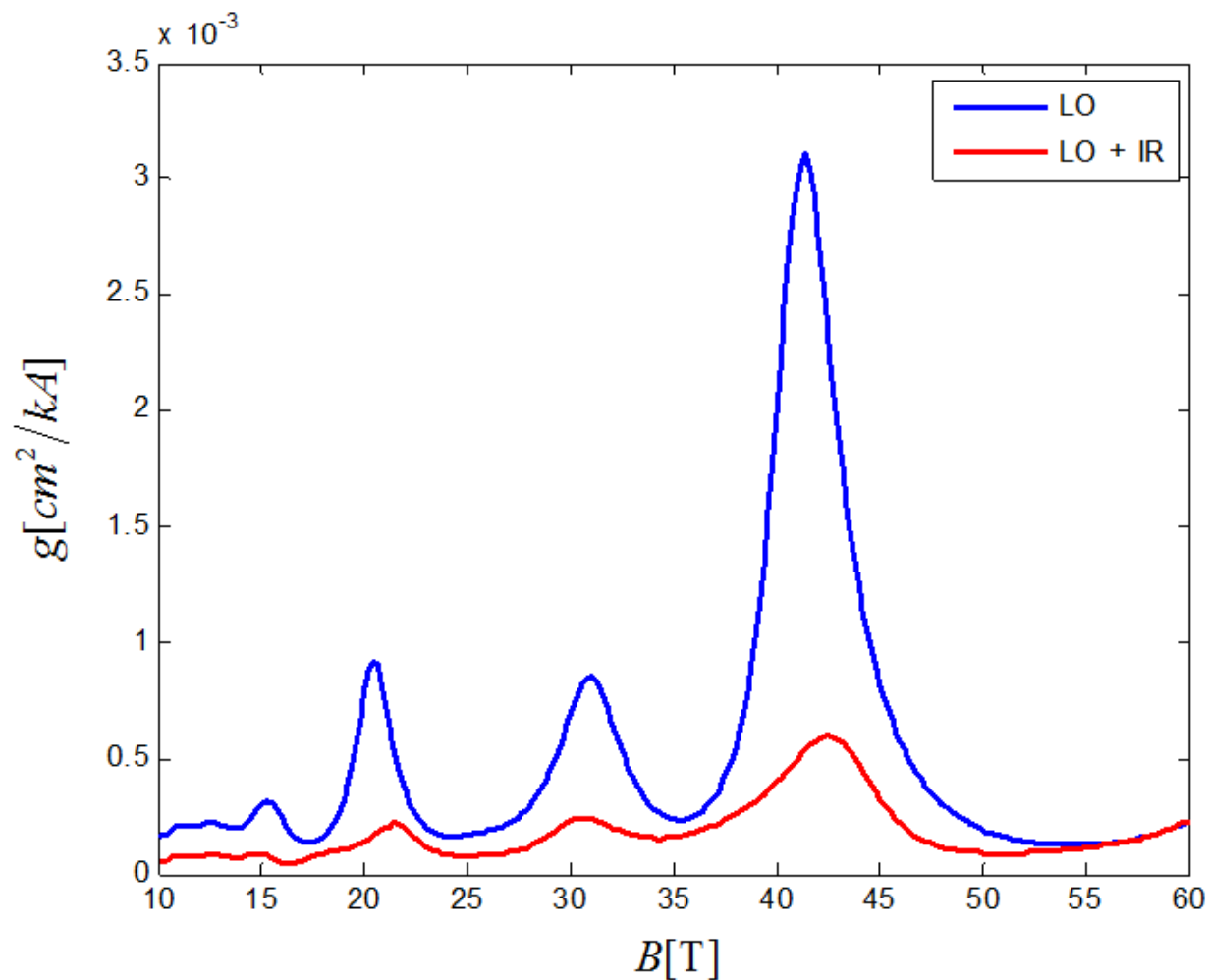

Lokalni minimum pojačanja

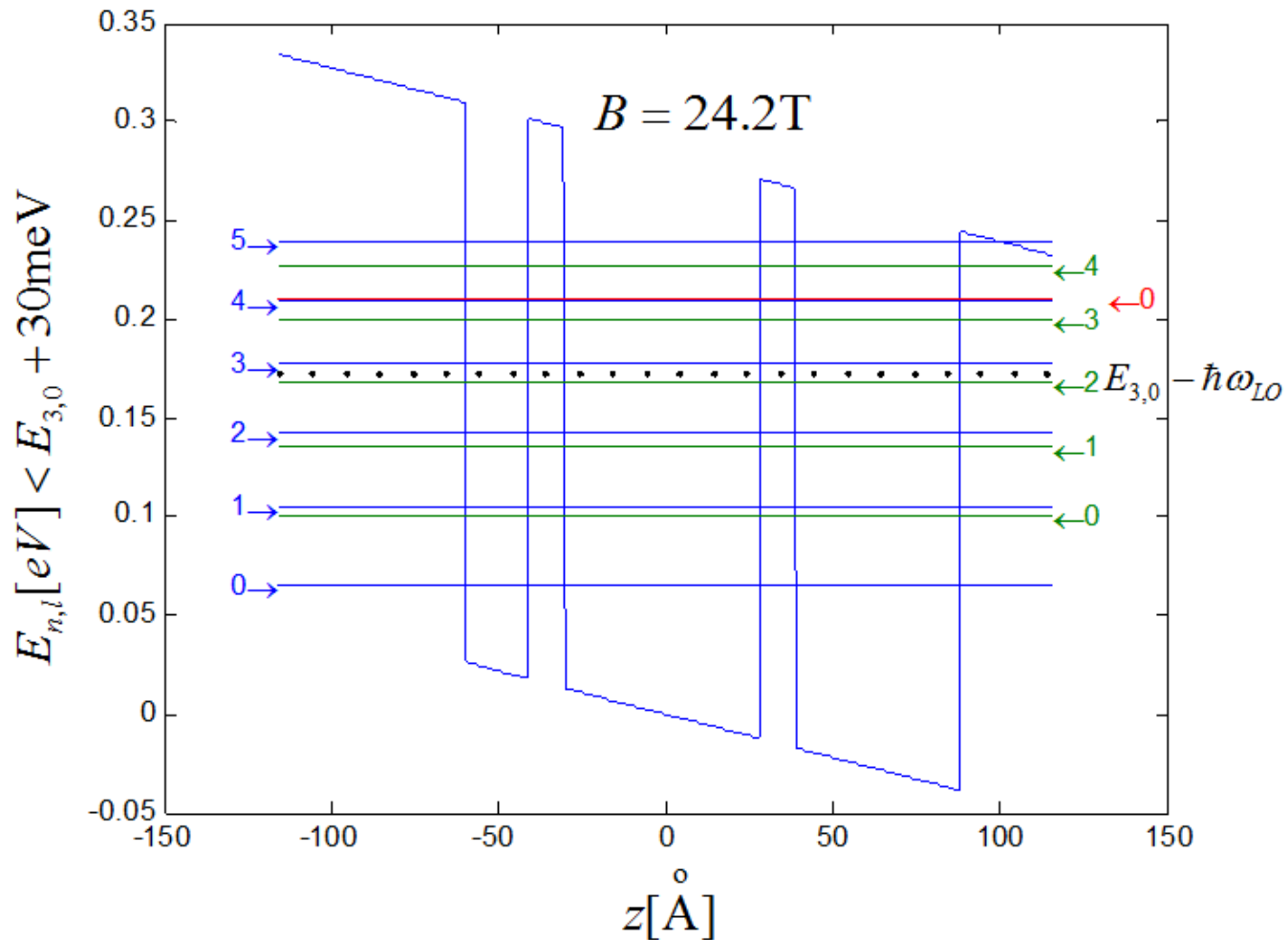

Lokalni maksimum pojačanja

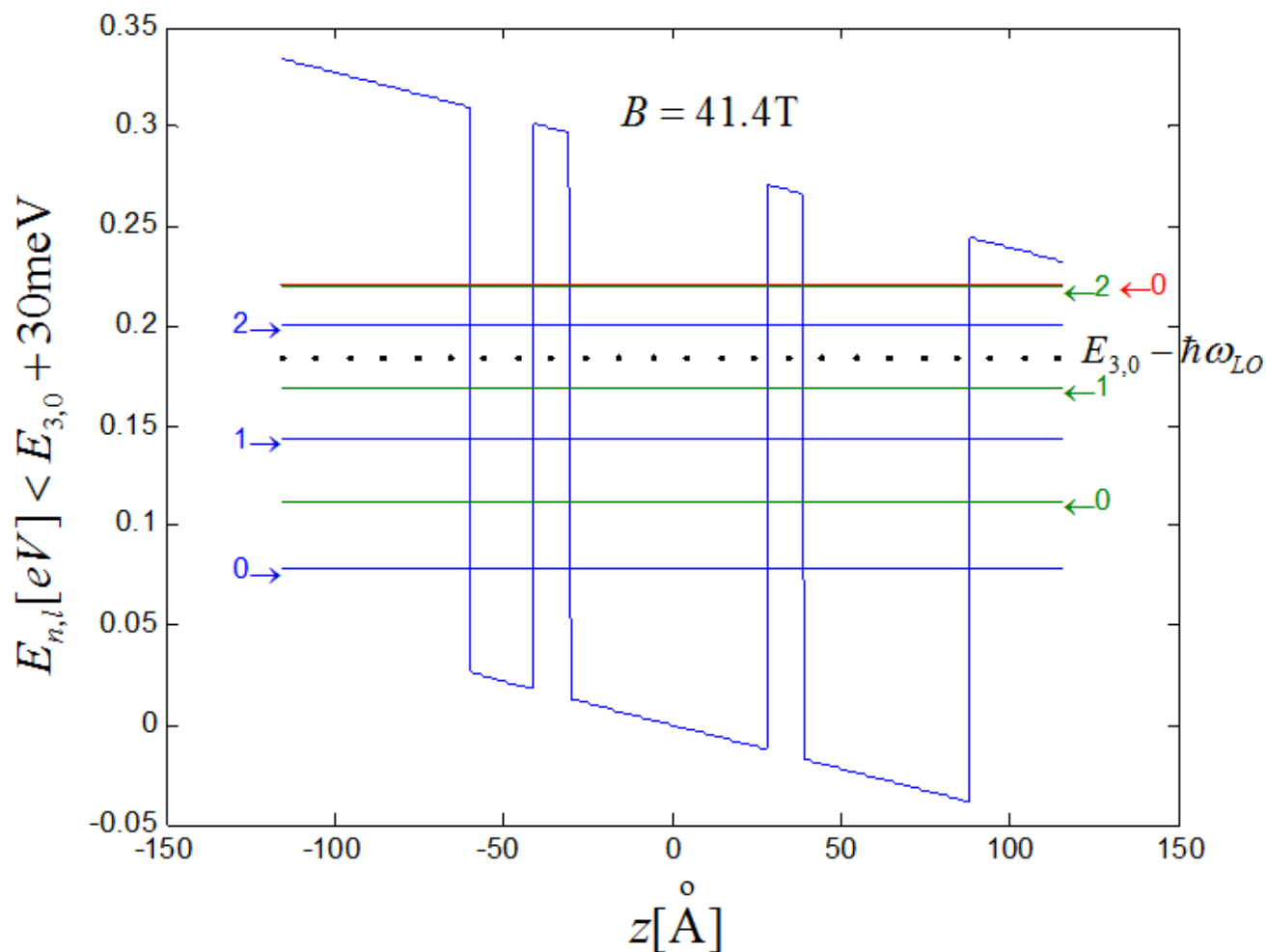

**Matlab, Nehalem, 12 min, $B < 10T$
PC < 1h**

Hvala na pažnji!

